

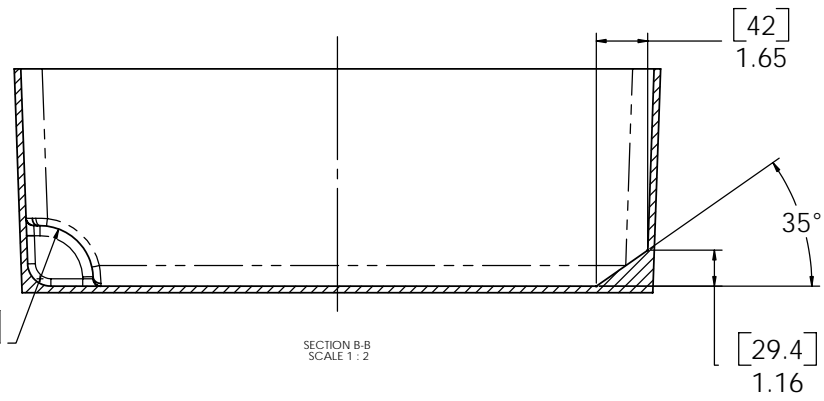

REVISIONS				
REV.	DESCRIPTION	DATE	DRTR	APPROV

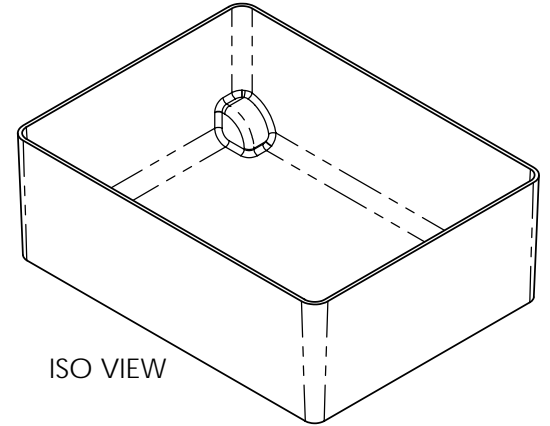
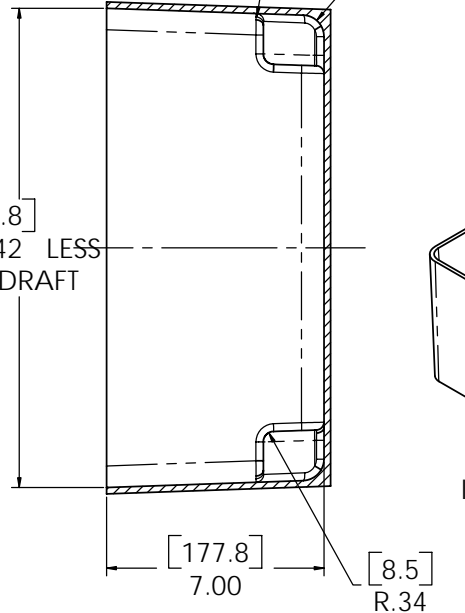
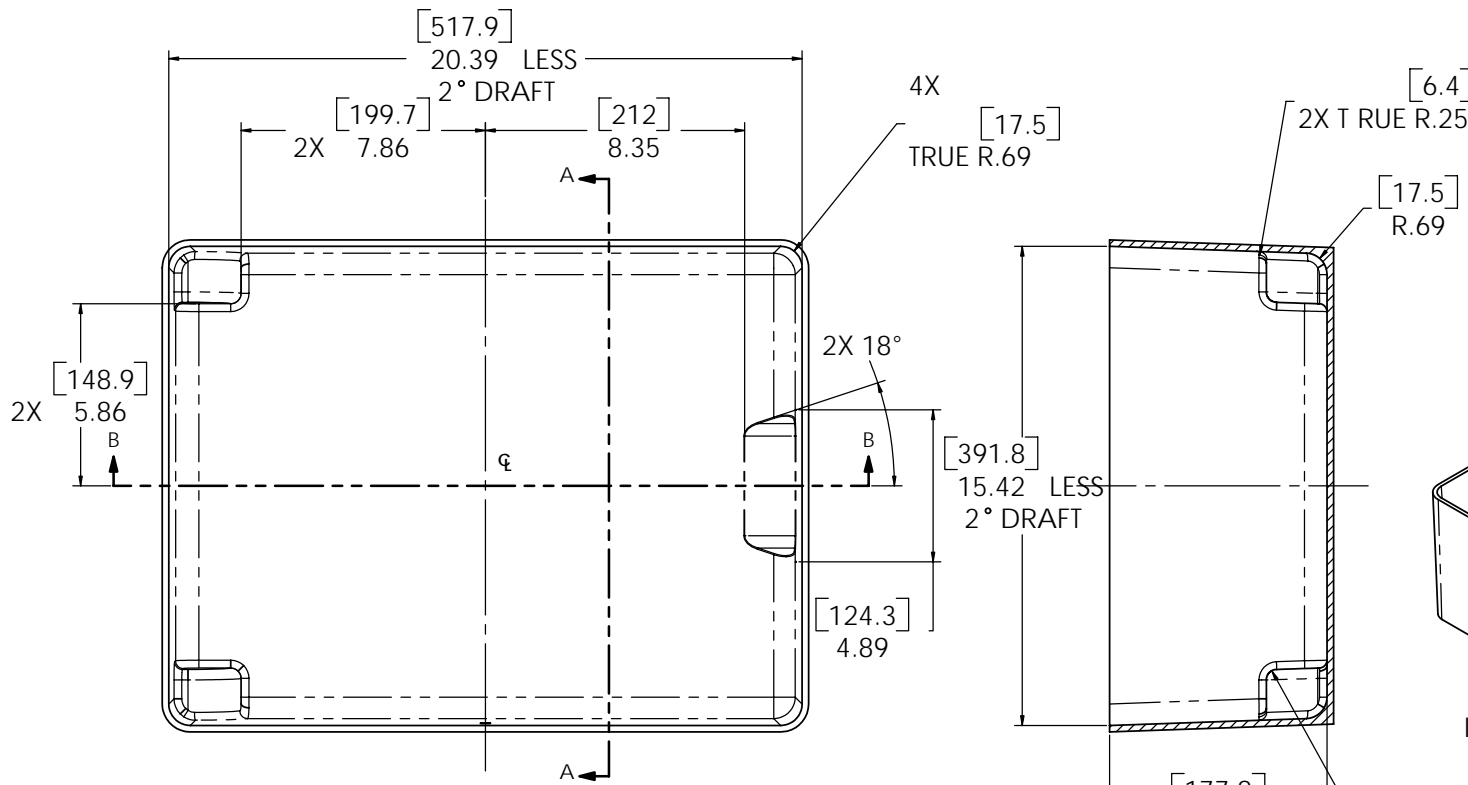

1. ALL DIMENSIONS ARE TO INTERNAL GEOMETRY OF CASE.
 NOTES: UNLESS OTHERWISE SPECIFIED.

	UNSPECIFIED TOLERANCES	APPROVALS	DATE	PELICAN PRODUCTS INC. 23215 EARLY AVE., TORRANCE, CA 90505 (310) 326-4700	
	<small>The Drawing contains information proprietary to Pelican Products Inc. Any reproduction, disclosure or use of this drawing requires written permission of Pelican Products Inc.</small>	TITLE 1560 CUBE CASE, BOTTOM INTERNAL GEOMETRY	SIZE D	SCALE 1:1	DRAWING NO. 1560
DO NOT SCALE DRAWING			1	OF	1