

REVISIONS				
REV.	DESCRIPTION	DATE	DRAWN	APPROVED
A	DAWING RELEASE	4/18/16	MH	MG

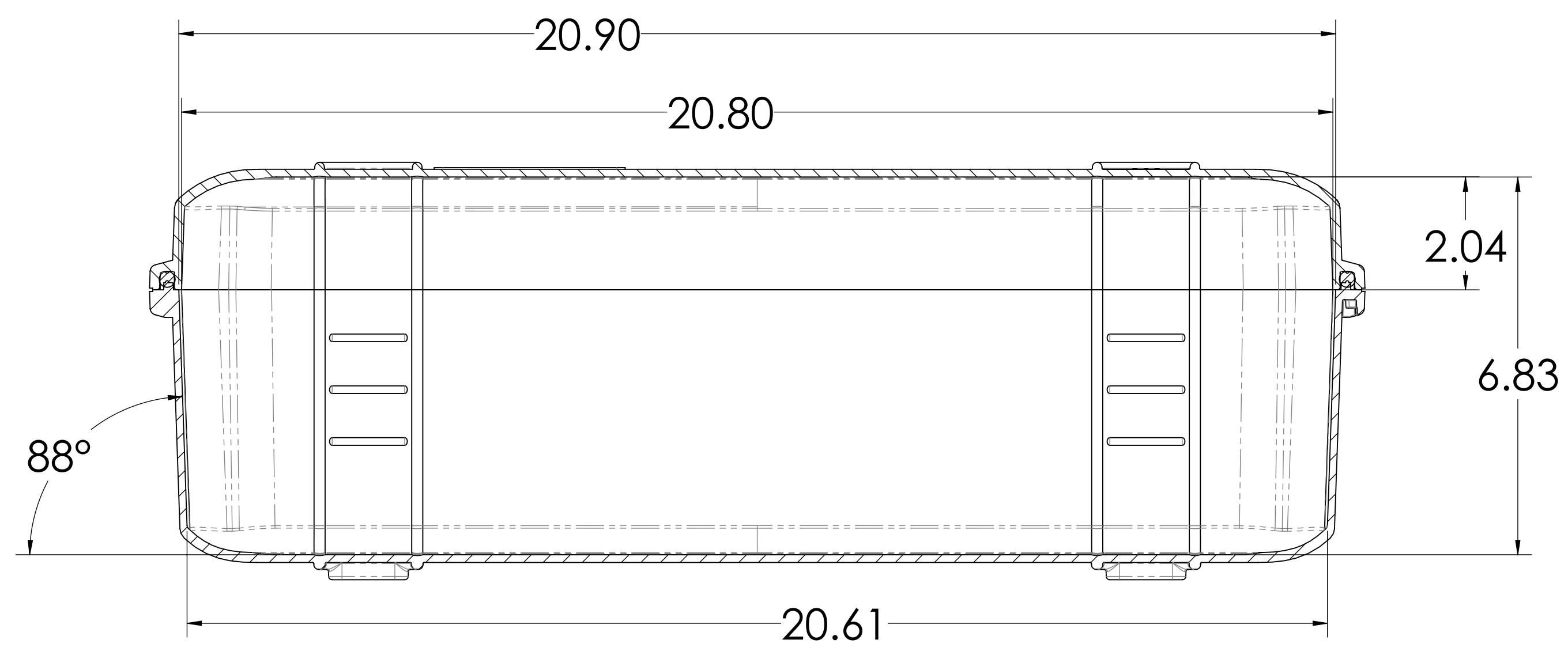

SECTION B-B

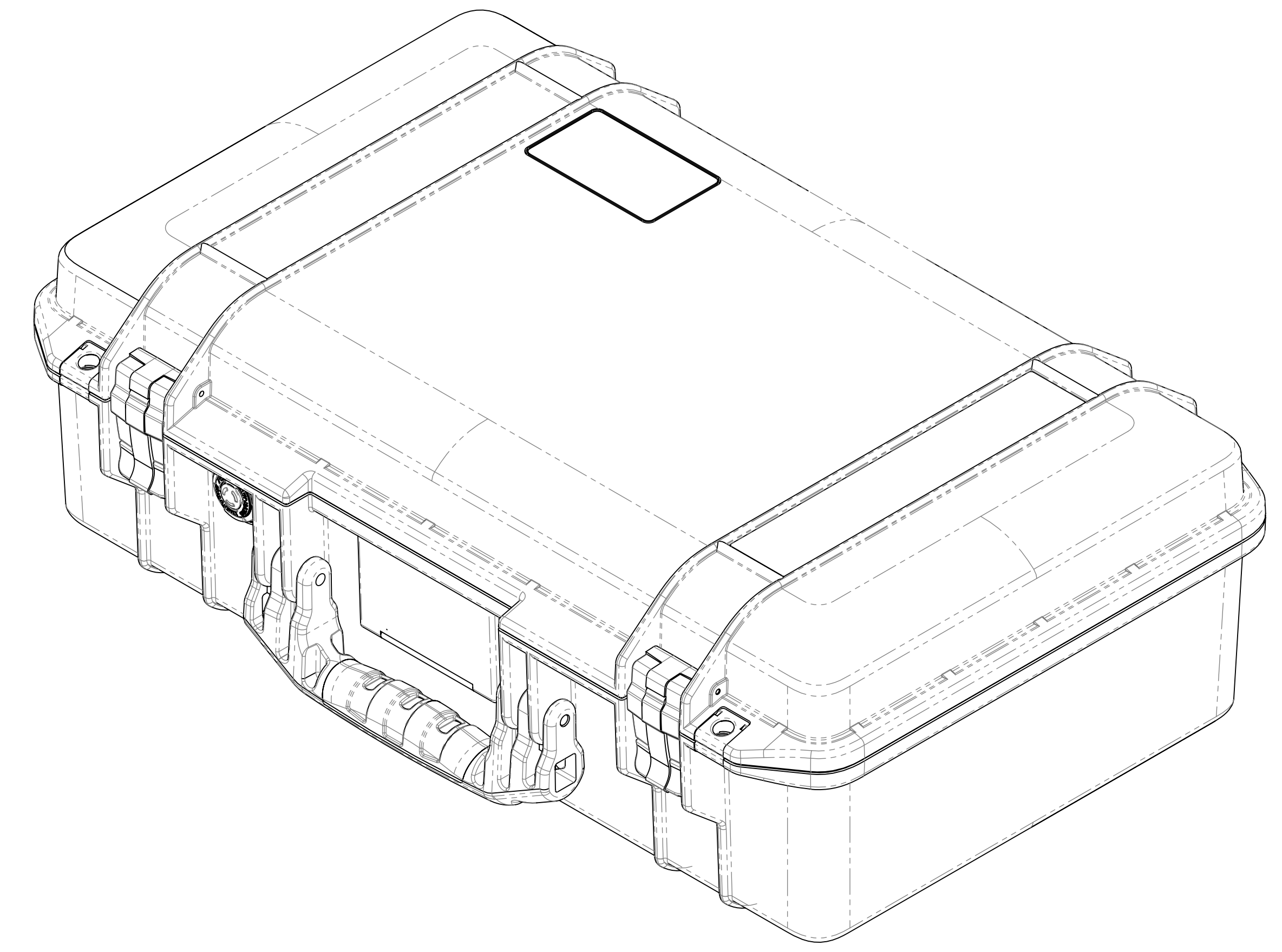
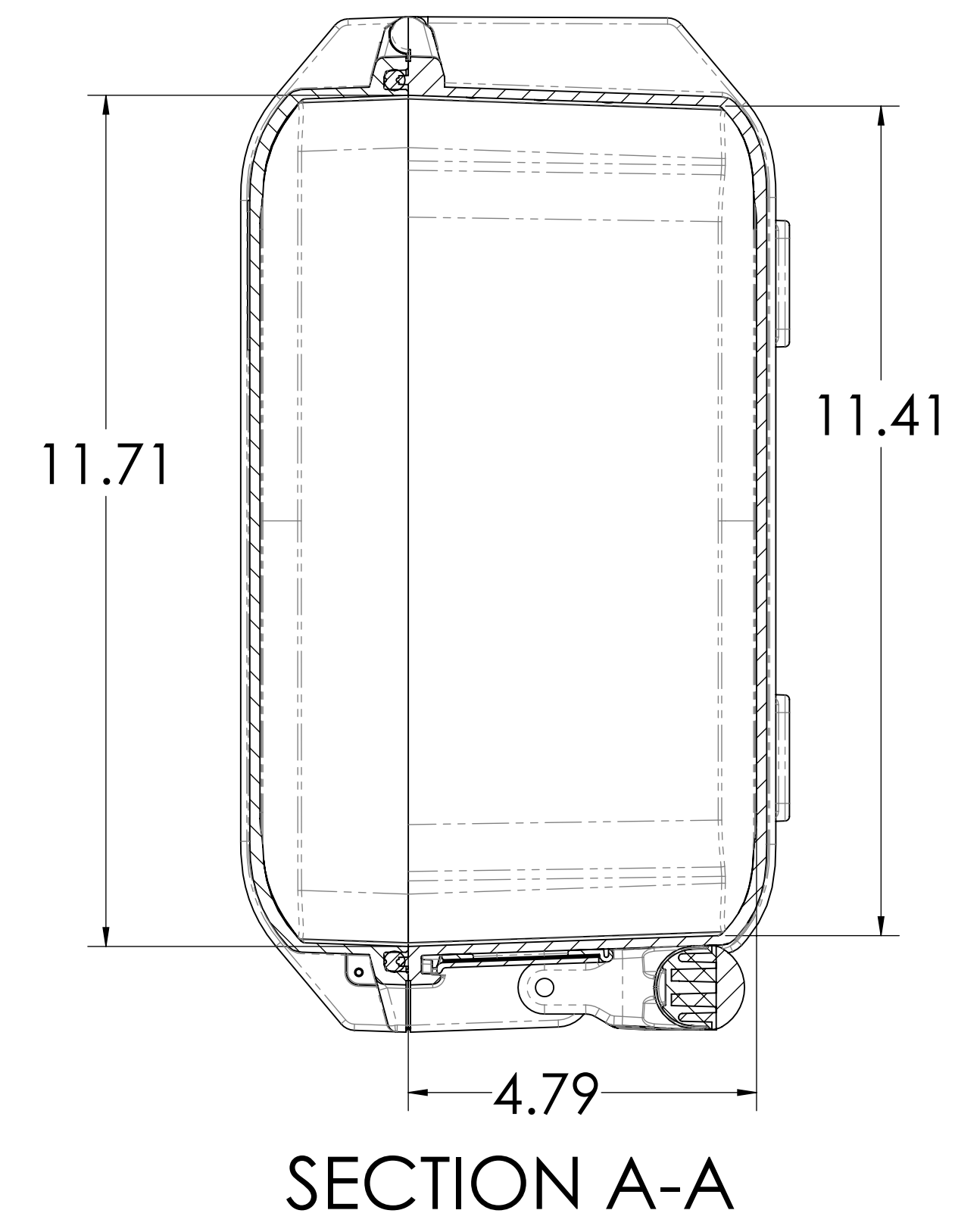
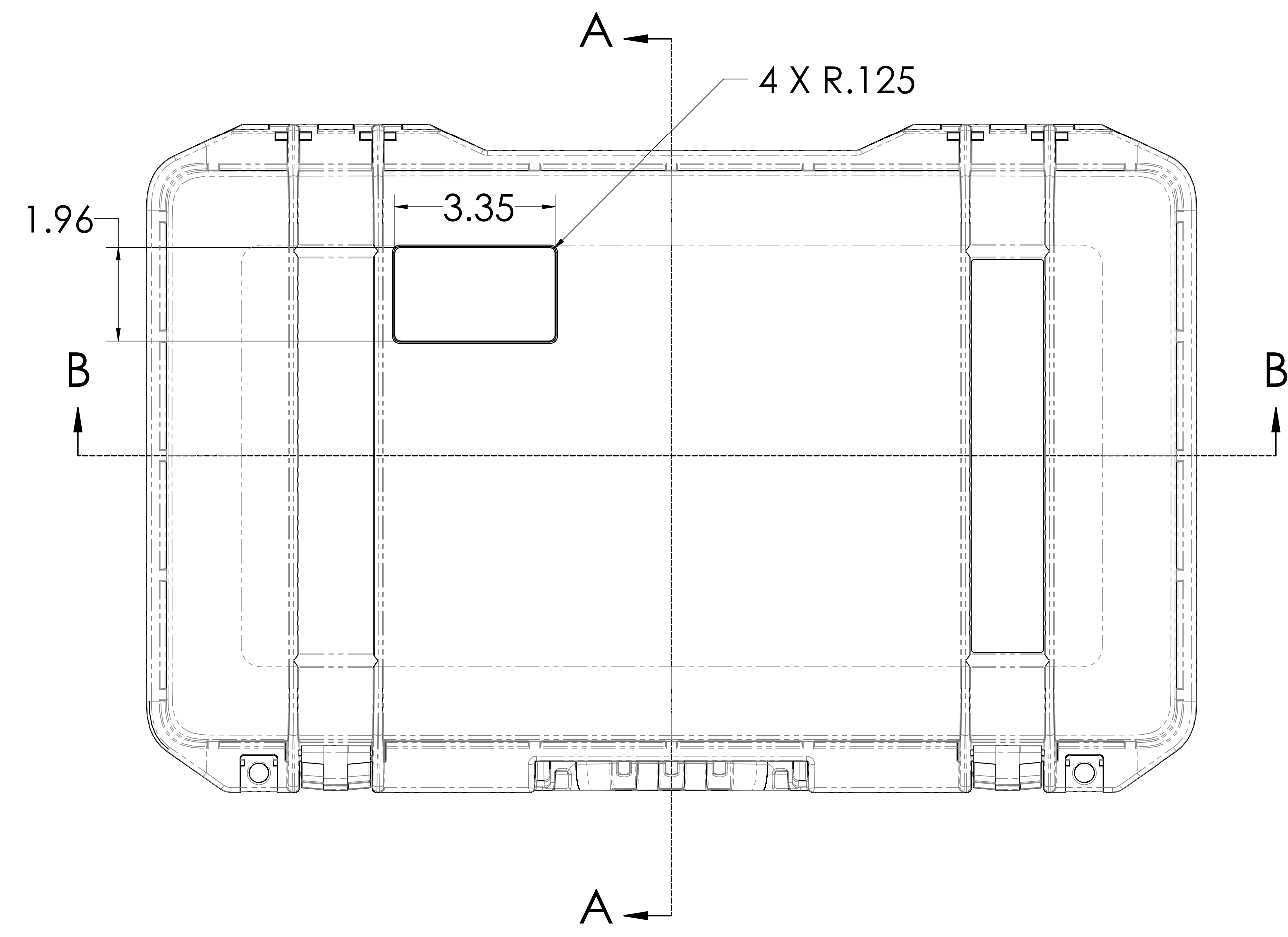
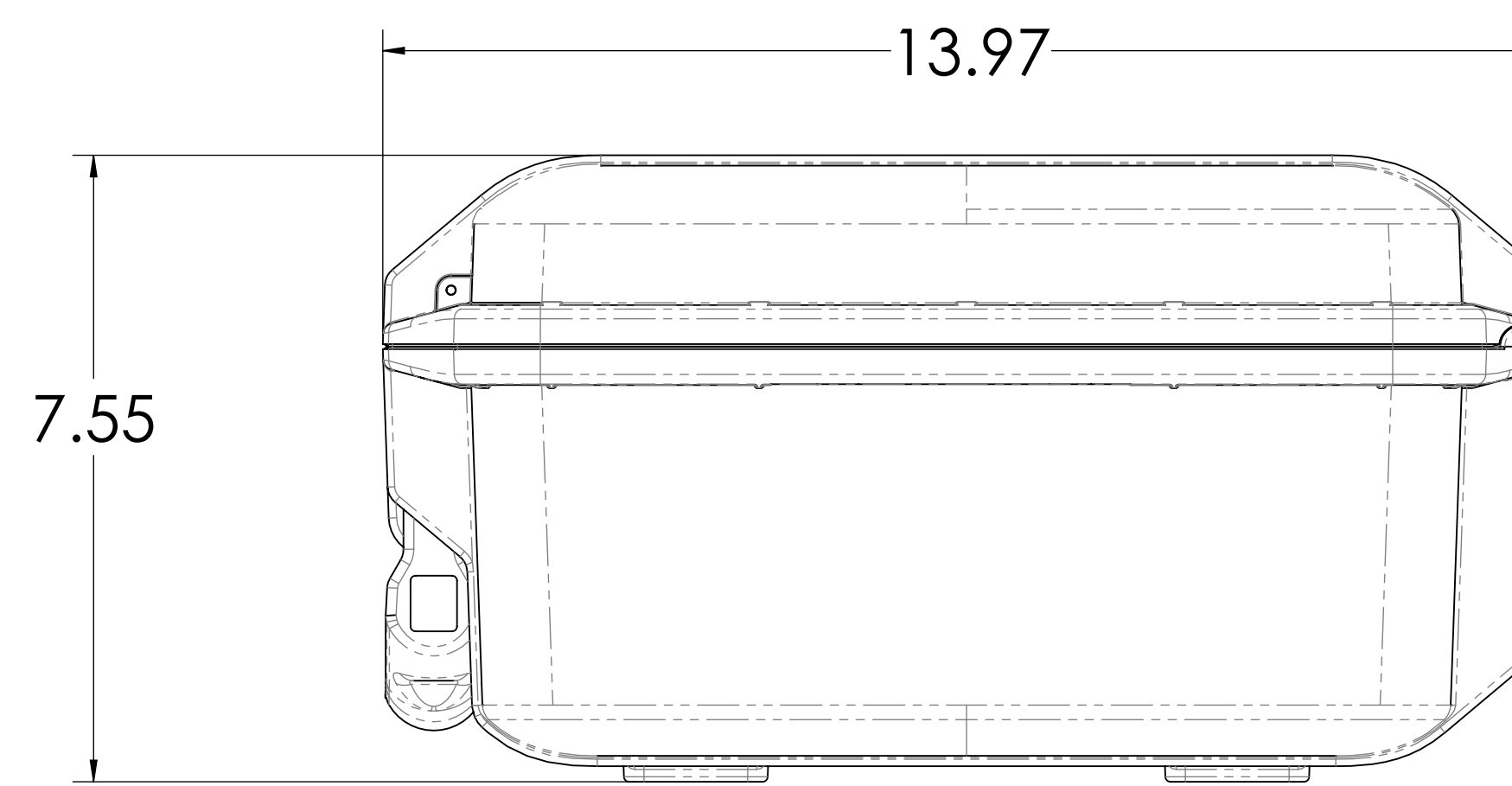
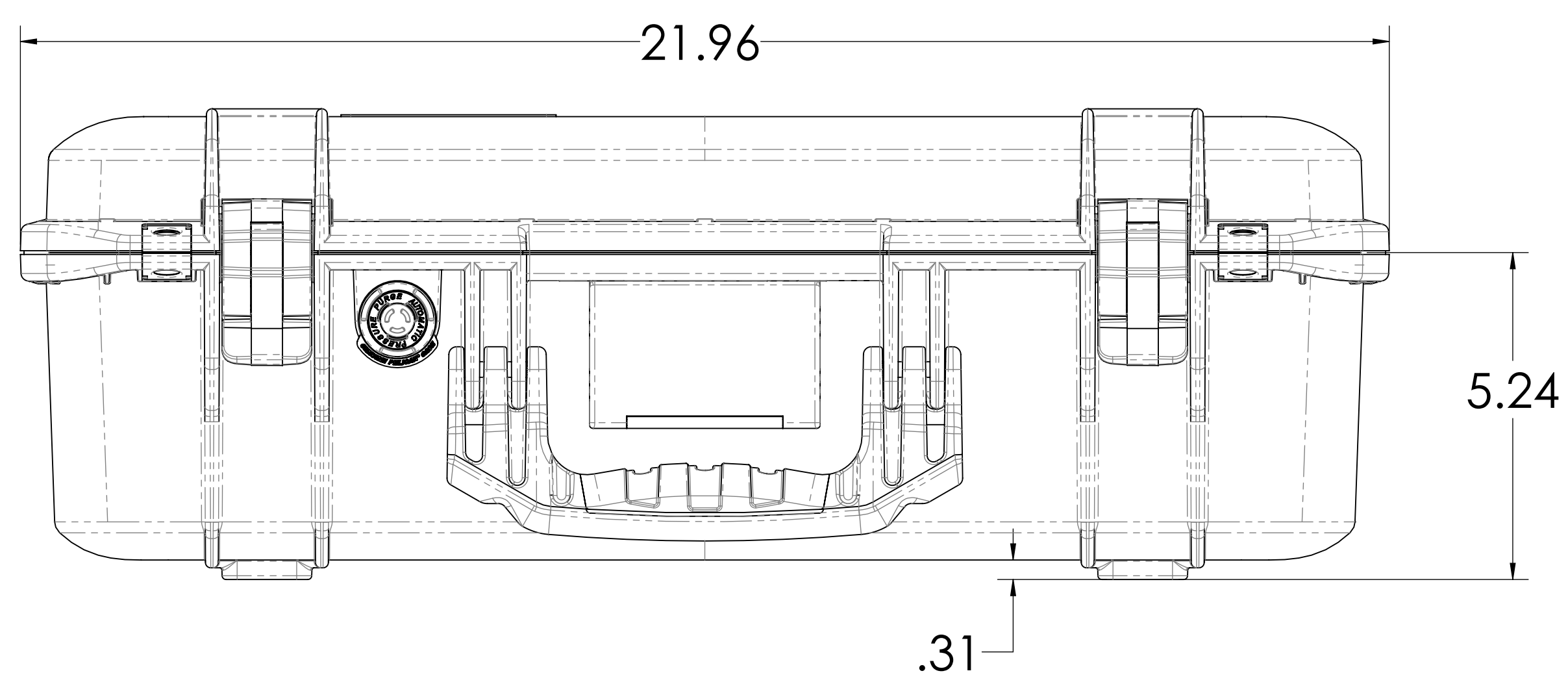

4: CORNERS ARE NOT TRUE RADIUS.
 3: FOR DETAILED INTERNAL DIMENSIONS SEE STEP OR IGES FILE.
 2: PRODUCT MUST BE REACH AND RoHS COMPLIANT.
 NOTE: 1-UNLESS OTHERWISE SPECIFIED.

TOLERANCE BLOCK	
INCHES	.XX $\pm 0.00 \pm 0.03$.XXX $\pm 0.00 \pm 0.03$ PER INCH
mm	X $\pm 0.25 \pm 0.75$.X $\pm 0.13 \pm 0.003$ PER mm
ANGLES	$\pm 0.25^\circ$

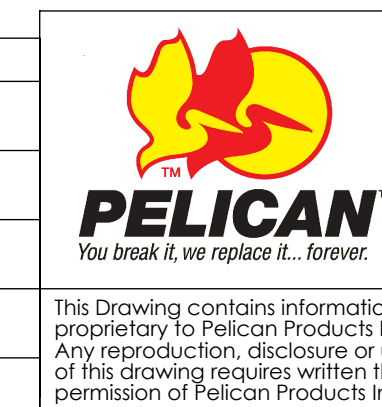

APPROVALS	DATE	PELICAN PRODUCTS INC.	
DATE: XX XXXX	2016 04 18	33215 EARLY AVE., TORRANCE, CA 90503 (310) 326-4700	
TITLE	1525 CASE ASSEMBLY	INTERIOR AND EXTERIOR DIMENSION	
SIZE	SCALE	DRAWING NO.	REV
E	1:2	015250-0000-CLR	A
DO NOT SCALE DRAWING		SHEET	OF
		1	3

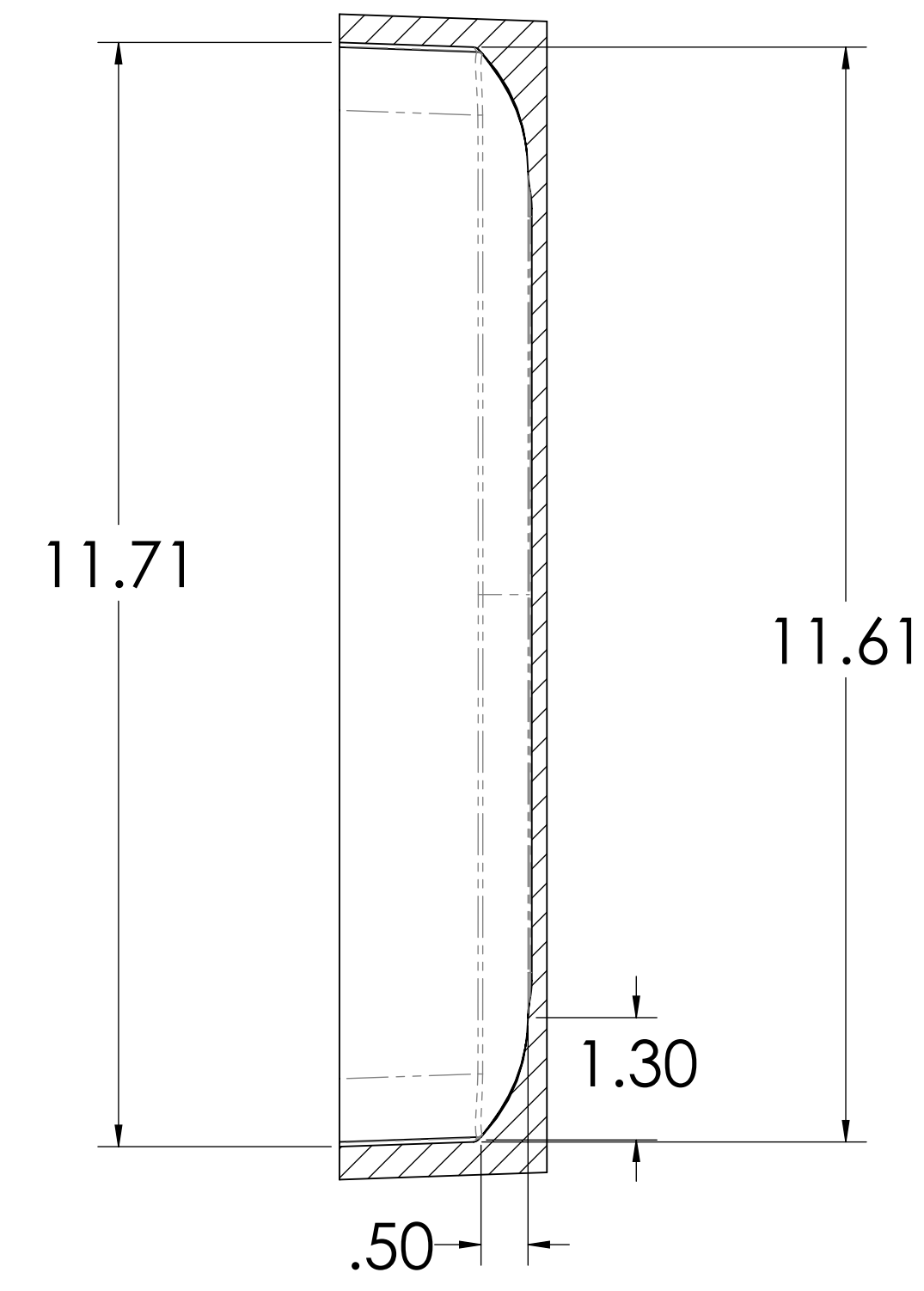
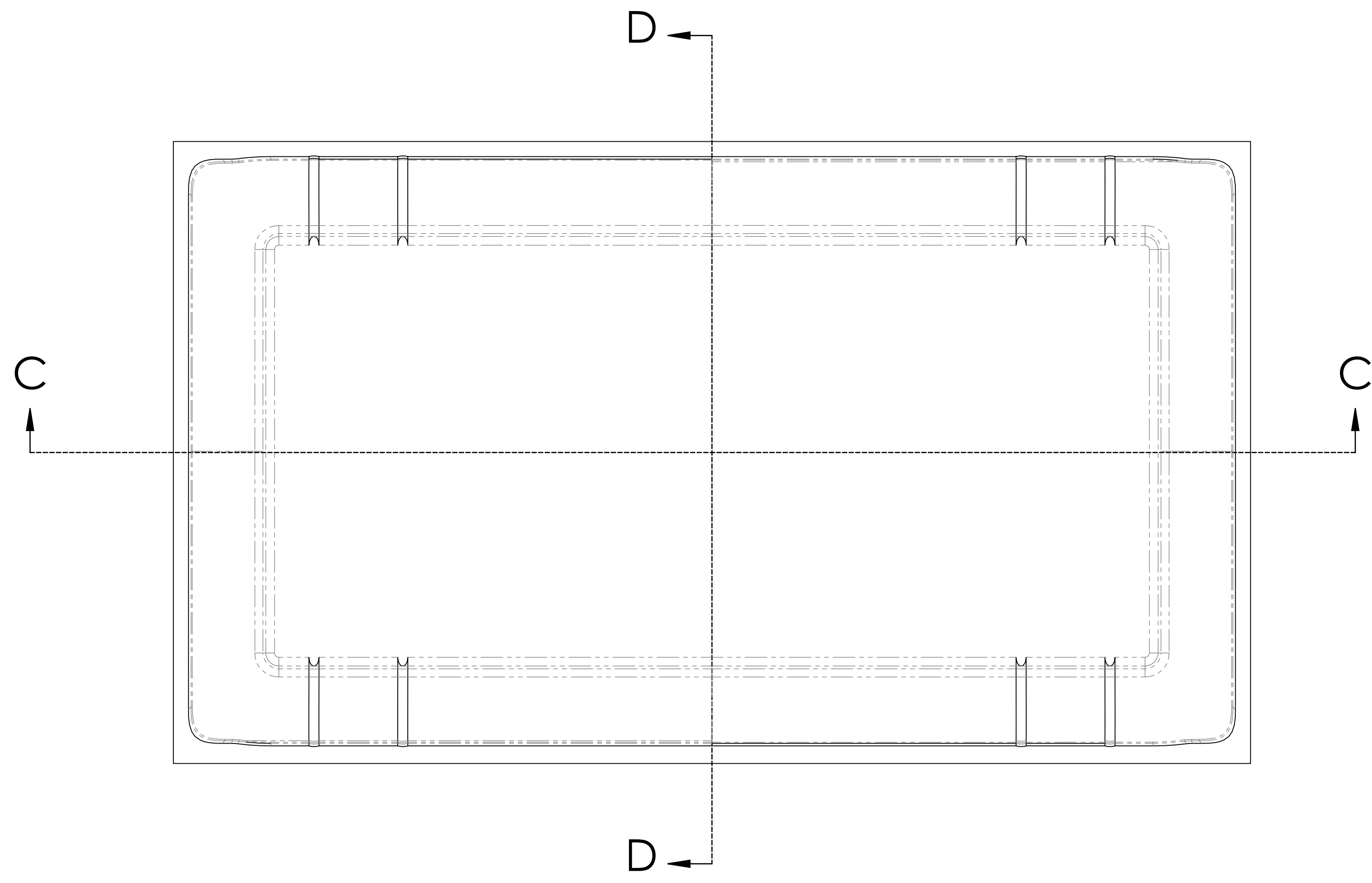

SECTION D-D
SCALE 1 : 1.75

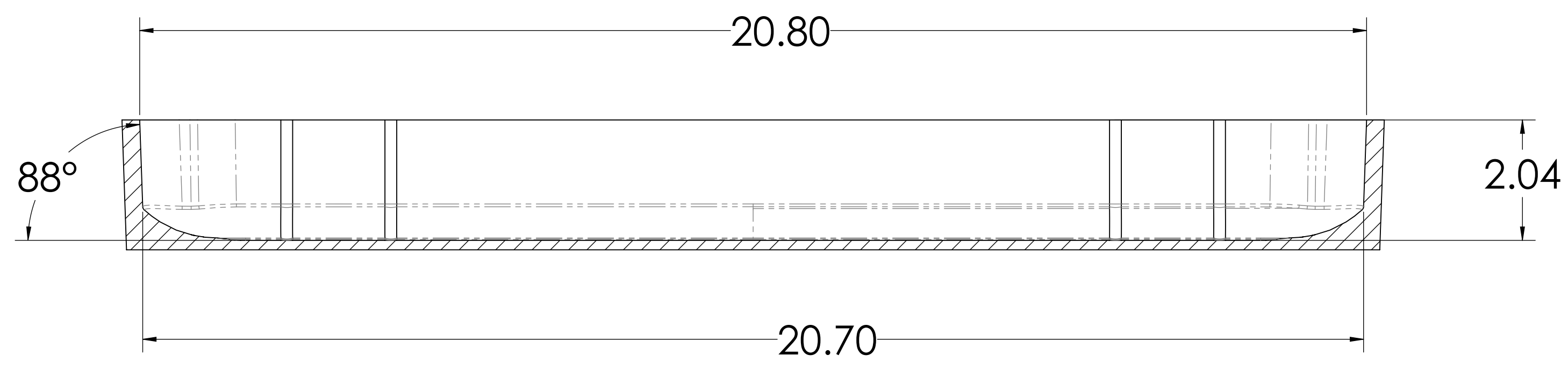
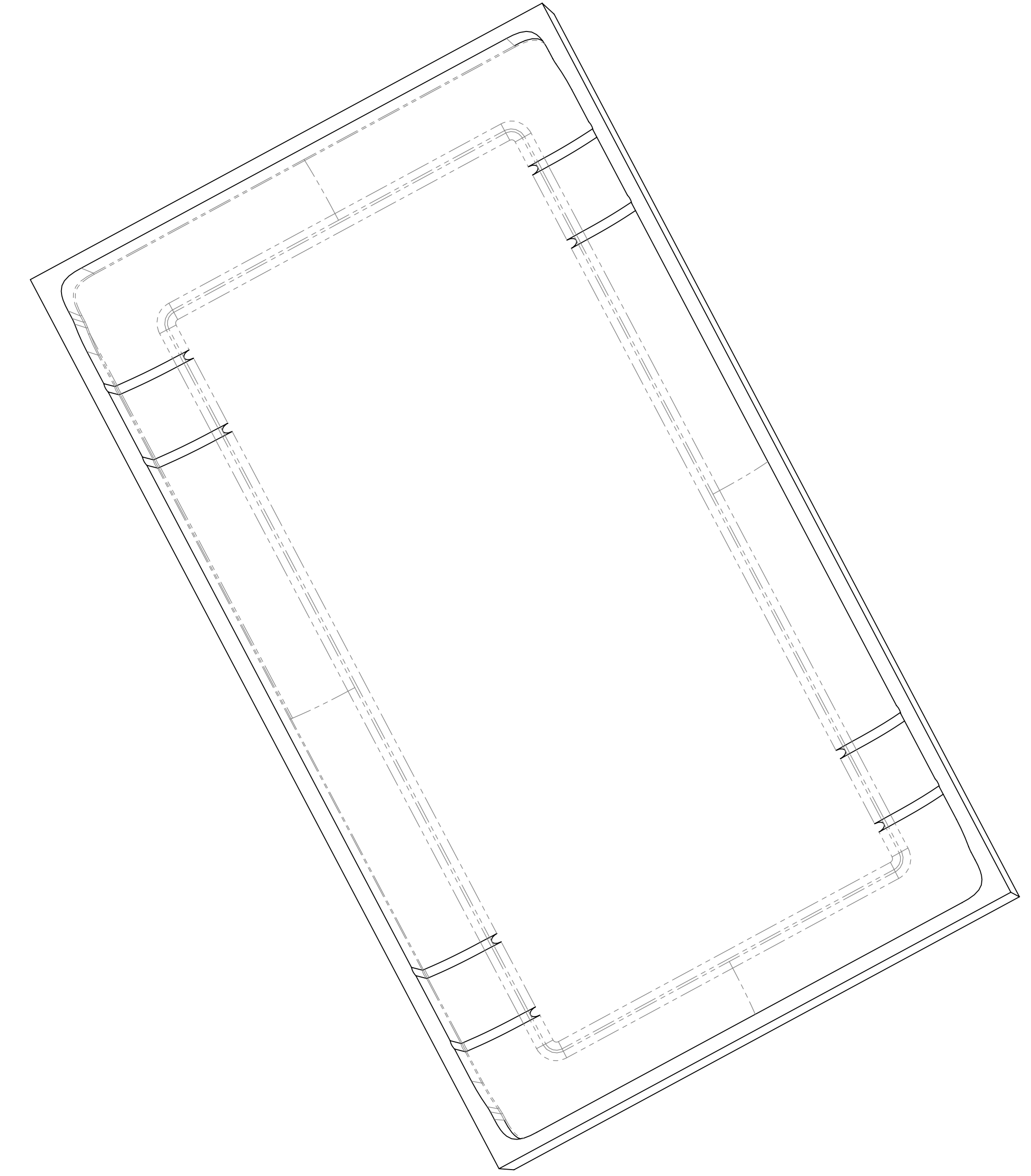

SECTION C-C
SCALE 1 : 1.75

1525 TOP TUB DRAWING INTERIOR DIMENSION

4: CORNERS ARE NOT TRUE RADIUS.
 3: FOR DETAILED INTERNAL DIMENSIONS SEE STEP OR IGES FILE.
 2: PRODUCT MUST BE REACH AND RoHS COMPLIANT.
 NOTE: 1-UNLESS OTHERWISE SPECIFIED.

TOLERANCE BLOCK		APPROVALS DATE		PELICAN PRODUCTS INC.	
INCHES	.XX ±.000	<10.00 ±.03	DATE	23215 EARLY AVE., TORRANCE, CA 90503 (310) 326-4700	TITLE
	.XXX ±.005	>10.00 ±.003 PER INCH	CHECKED		1525 TOP TUB DRAWING
mm	X ±.254	<254 ±0.75	APPROVED		DRAWING NO.
	.X ±0.13	>254 ±0.003 PER mm			SCALE
ANGLES	∠	±.25°			REV
					A

DO NOT SCALE DRAWING SHEET 2 OF 3

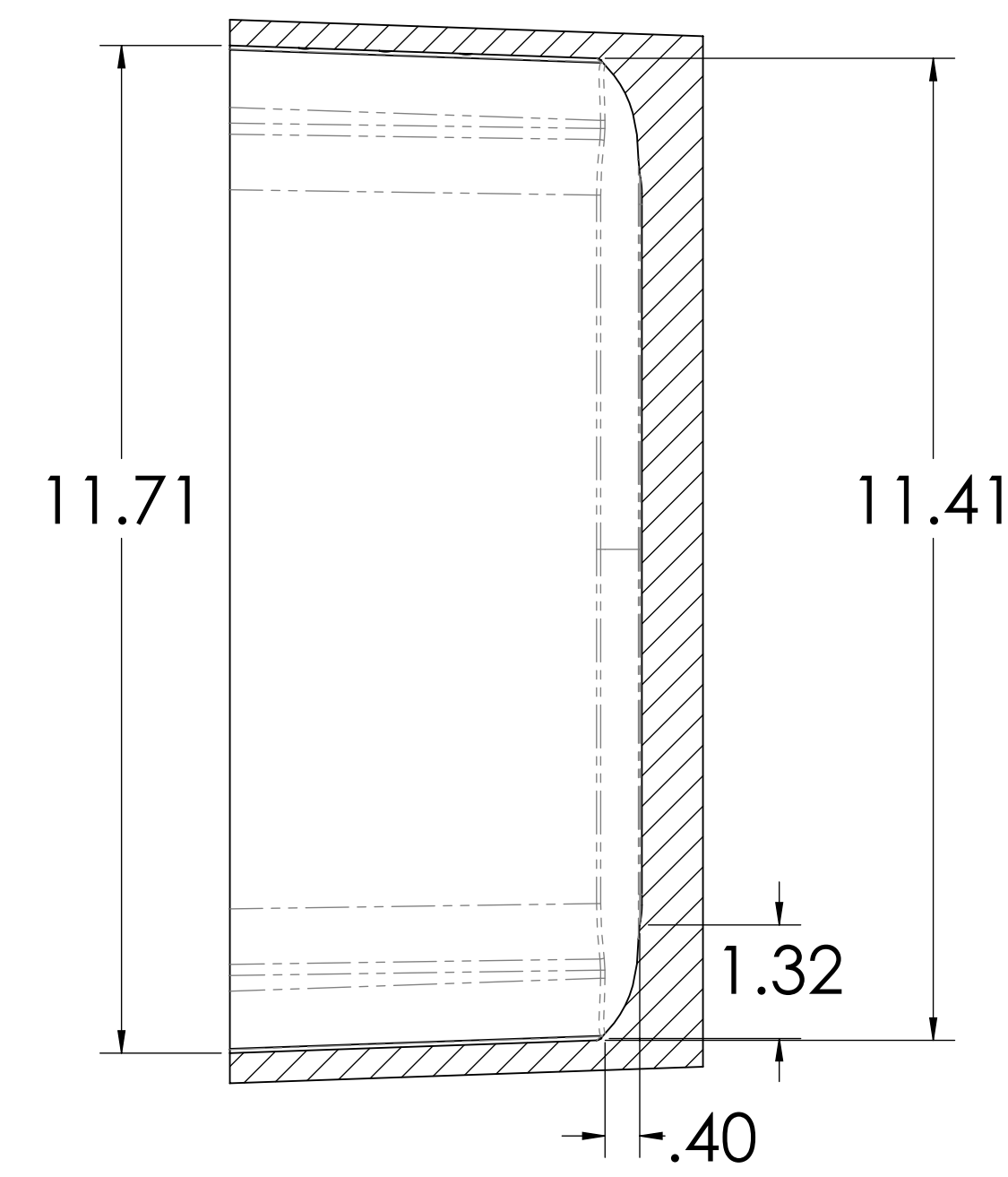
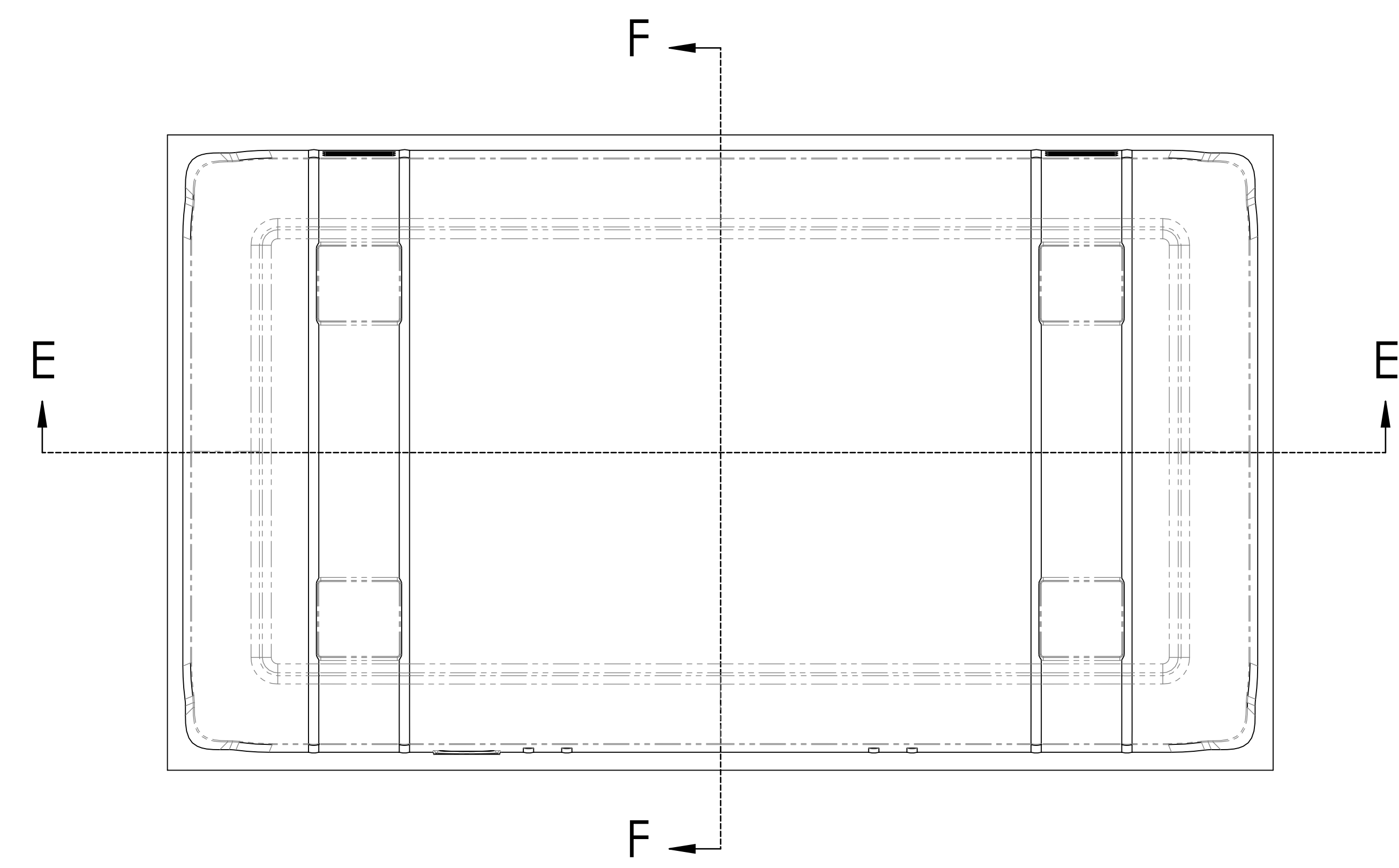

SECTION F-F

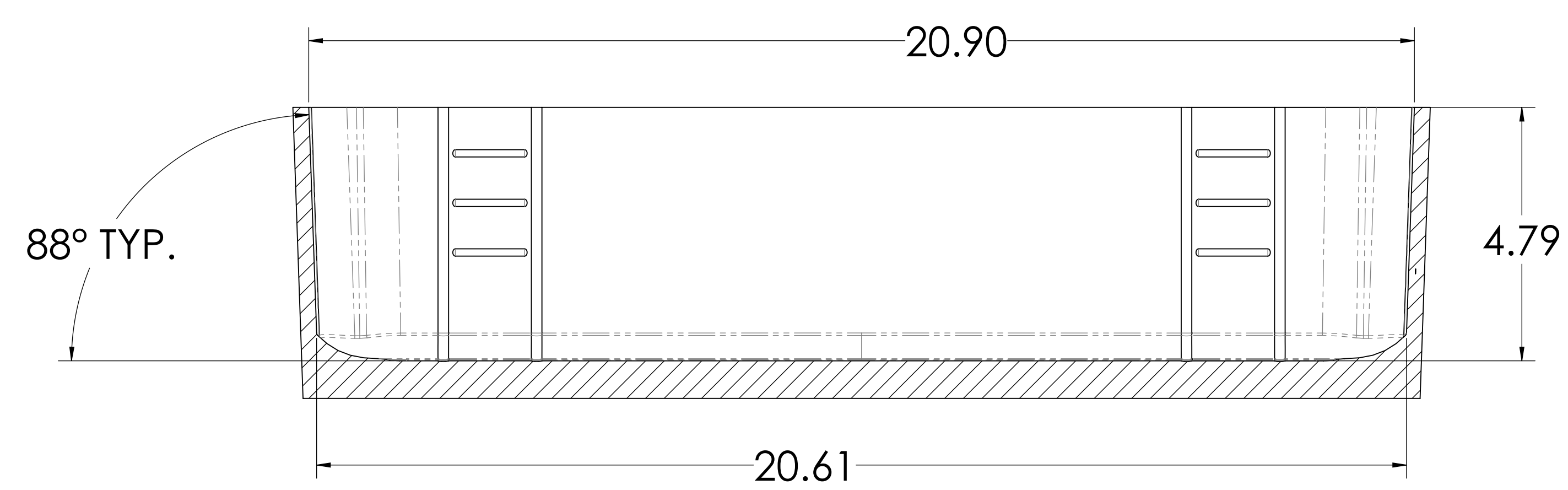
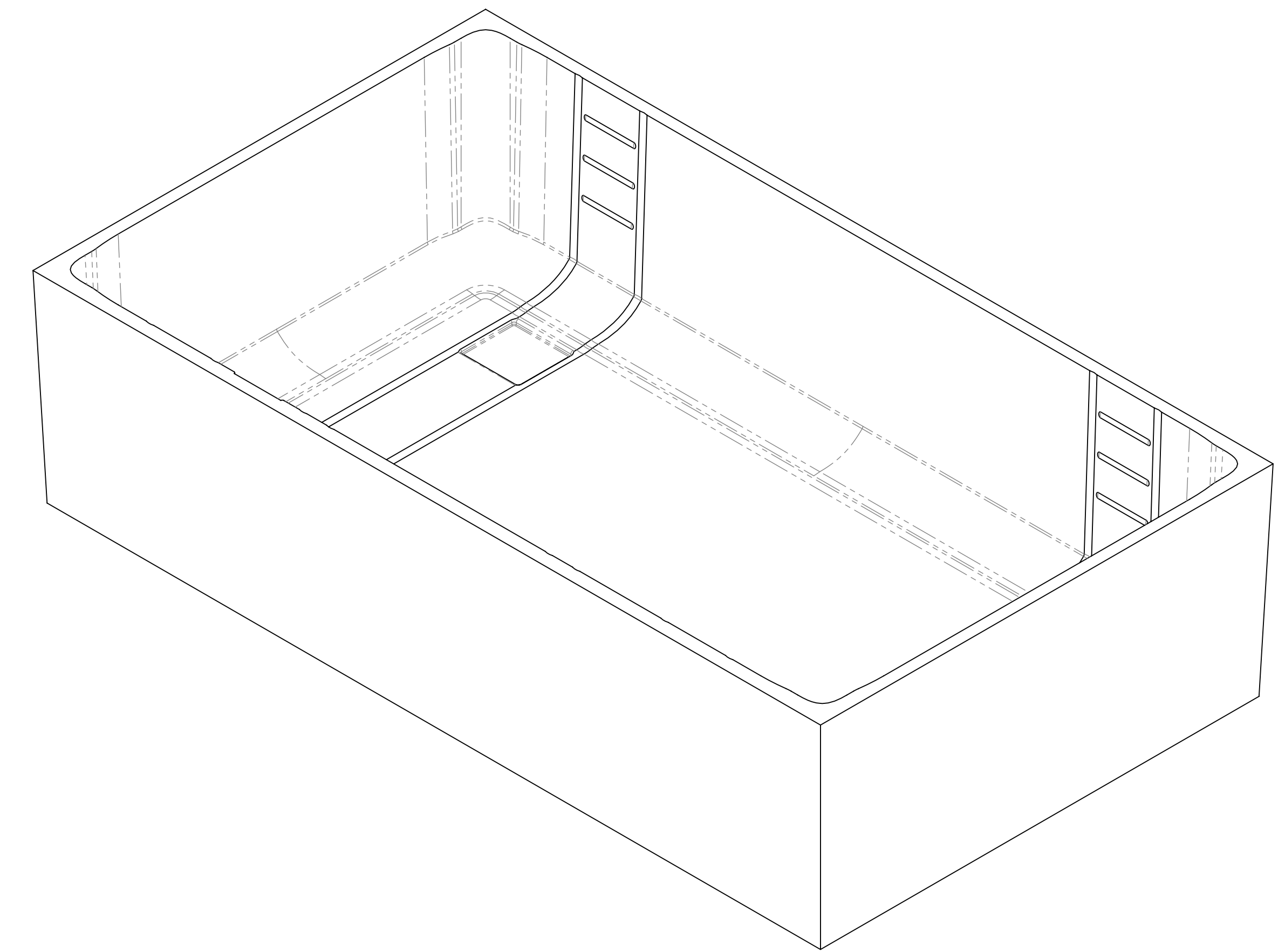

SECTION E-E

1525 BOTTOM TUB DRAWING INTERIOR DIMENSION

4: CORNERS ARE NOT TRUE RADIUS.
 3: FOR DETAILED INTERNAL DIMENSIONS SEE STEP OR IGES FILE.
 2: PRODUCT MUST BE REACH AND RoHS COMPLIANT.
 NOTE: 1-UNLESS OTHERWISE SPECIFIED.

TOLERANCE BLOCK		APPROVALS DATE		PELICAN PRODUCTS INC.	
INCHES	.XX <10.00 ±.03 ≥10.00 ±.003 PER INCH	DATE	XXXX	23215 EARLY AVE., TORRANCE, CA 90503 (310) 326-4700	
	.XXX ±.005	CHECKED		TITLE	
mm	X ≤254 ±0.75 >254 ±0.003 PER mm	APPROVED		1525 BOTTOM TUB DRAWING	
ANGLES	∠ ±.25°			SIZE	SCALE
				E	1:2
				DRAWING NO.	REV
					A
				DO NOT SCALE DRAWING	SHEET 3 OF 3

