

MODEL RTA-983BC

ASSEMBLY INSTRUCTIONS

Thank you for purchasing our product.

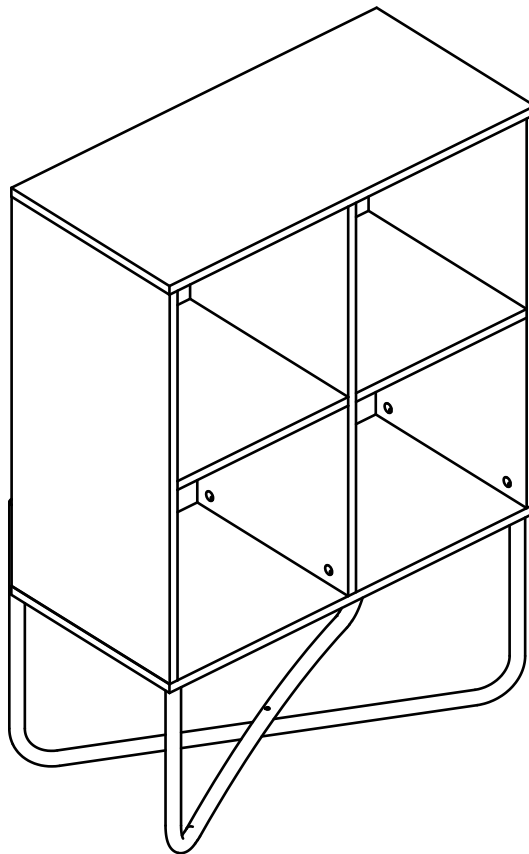

REV-CAR-6643-0622



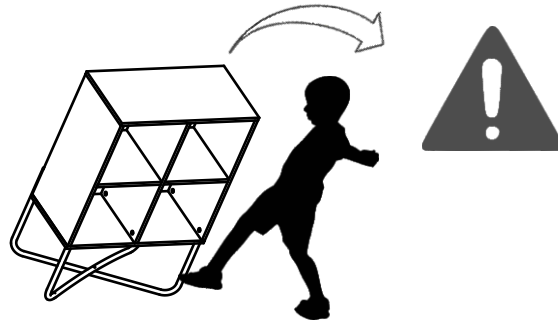

- Please read throughly the warning about the danger of tip-over in page **13** of the assembly instructions.



- Please read carefully the assembly instructions before the installation.



- Do not discard this manual or any of the packaging material until the unit has been completely assembled.



- Might require two people.

MAIN PARTS LIST

1 Bottom Panel

x1

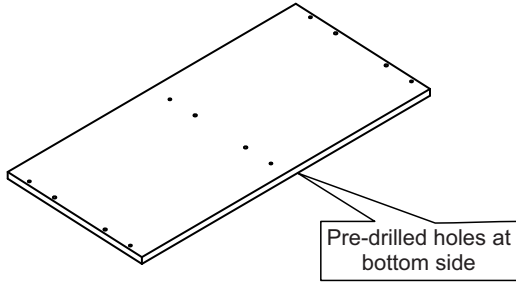

2 Top Panel

x1

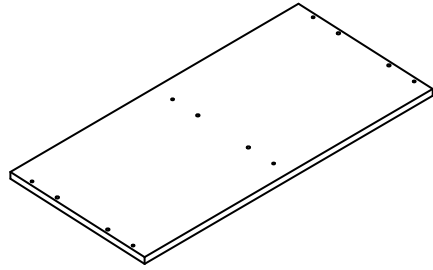

3 Right Side Panel

x1

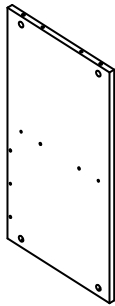

4 Left Side Panel

x1

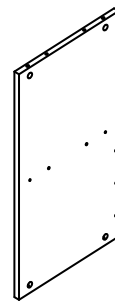

5 Division Panel

x1

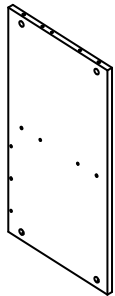

6 Straight Frame

x1

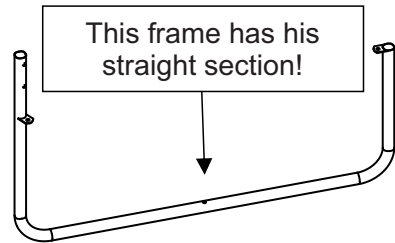

7 Curved Frame

x1

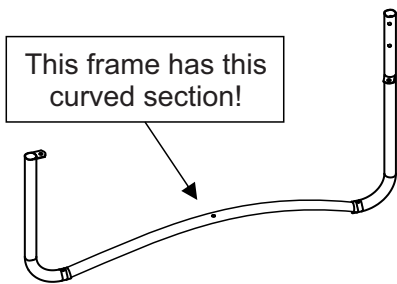

8 Shelf

x2

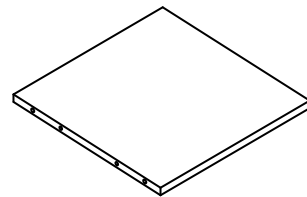

9 Back Panel



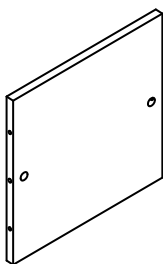



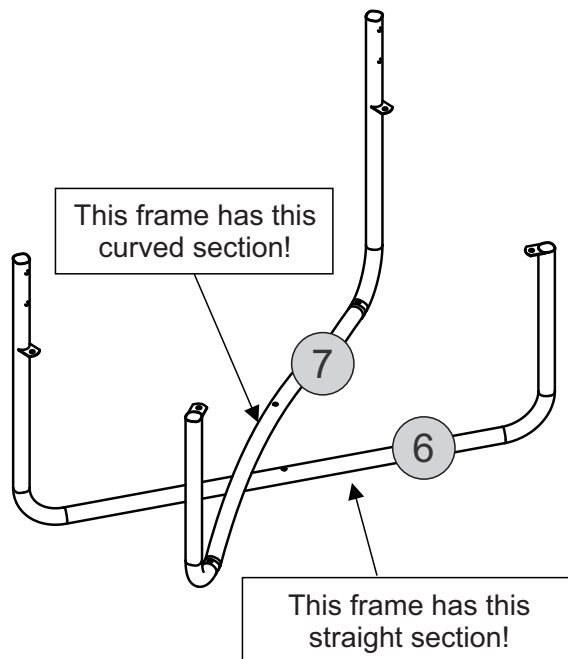
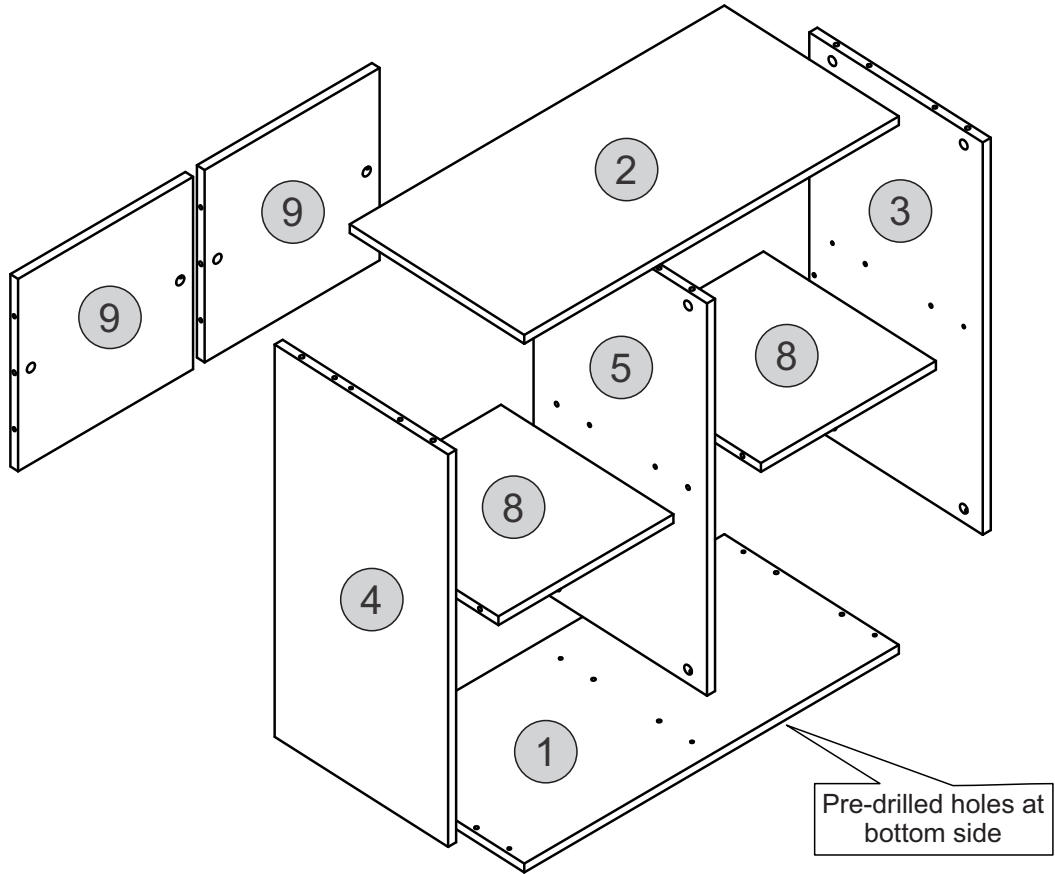



x2

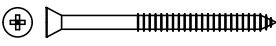

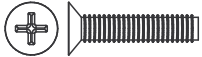
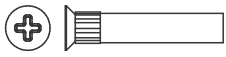
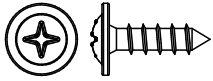
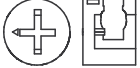
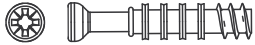

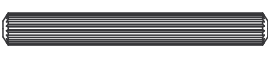
MAIN PARTS LAYOUT (FOR REFERENCE)

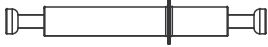

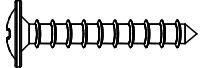
LIST OF INCLUDED HARDWARE

PART	QTY	ITEM	
A	4	Bottom Glide	
B	2	6x35 Anchor	
C	2	M4x60	
D	26	Hole Cover	
E	1	M4x20	
F	1	M4x27	
G	4	M4x14	
H	24	Cam Lock	
I	18	Cam Bolt	
J	20	M6x30	
K	4	M6x50	
L	2	Cap	
M	4	M4x35	
N	3	Double Cam Bolt	
O	4	Washer	
P	2	Wall Strap	
Q	2	M3.5x30	

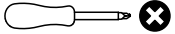
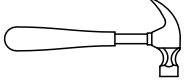
TOOLS YOU WILL NEED (NOT INCLUDED)

Phillips Screwdriver	
Hammer	
Power Driller and Ø6mm drill bit	
Pencil	

This unit uses cam bolts and locks. The following explains how to use them. This is not an assembly step; it is a guide for when you are actually doing the assembly using this kind of hardware.

Cam lock

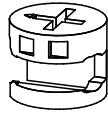

Cam bolt

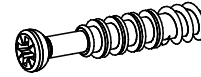

1. Screw the bolt into the corresponding hole on panel "A".

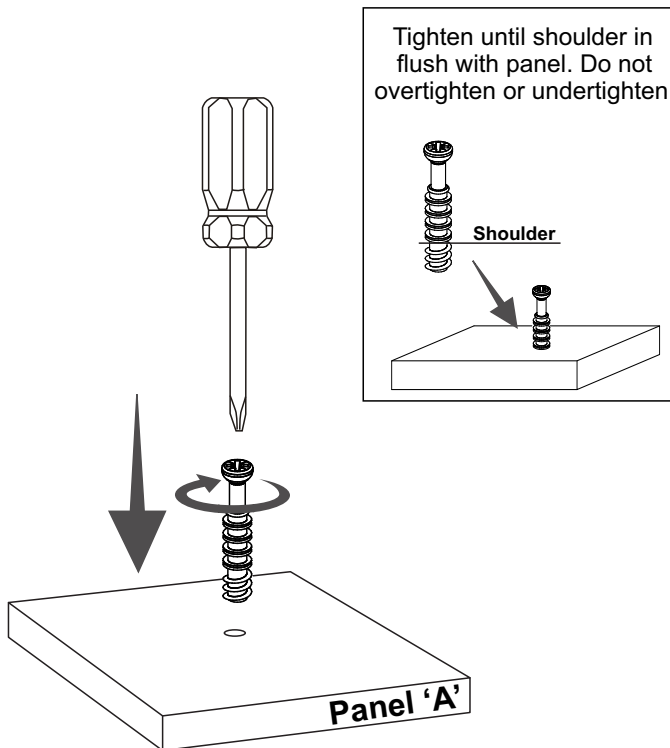

2. Join panel "B" to panel "A". If panel "B" comes with the cam lock pre-installed, make sure it is aligned to receive the bolt's head (refer to point 3). There might be a very small gap between the panels which is normal.

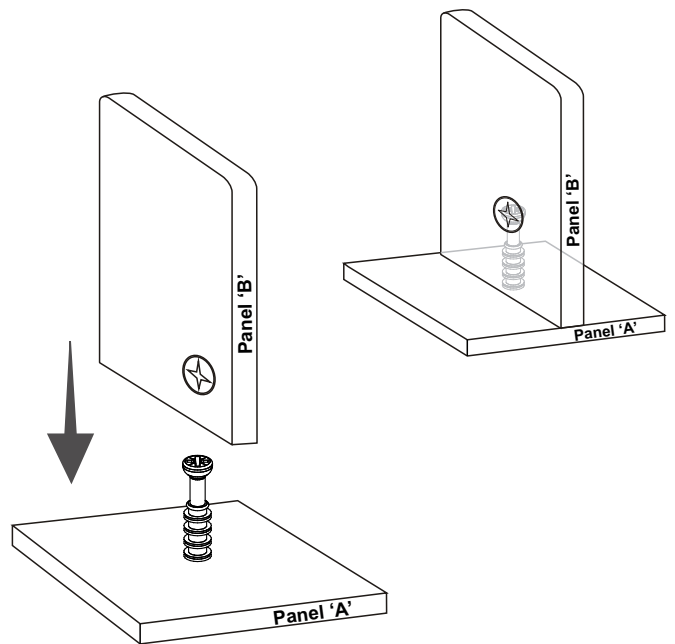

3. Insert the cam lock on panel "B" making sure it goes aligned to receive the bolt's head.

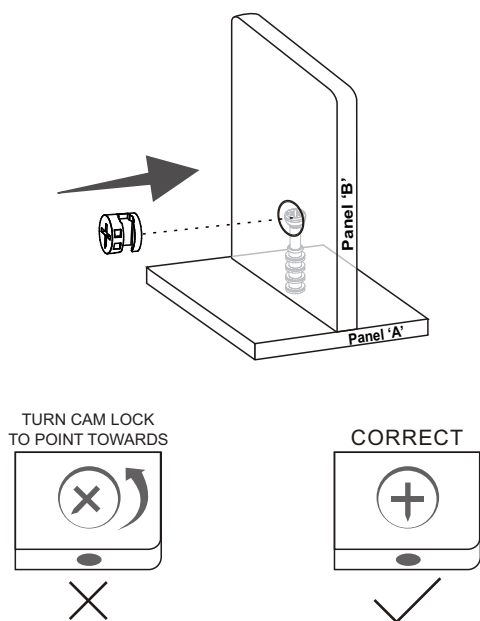

4. Turn the cam lock clockwise. This will lock the parts together and will close any gaps.

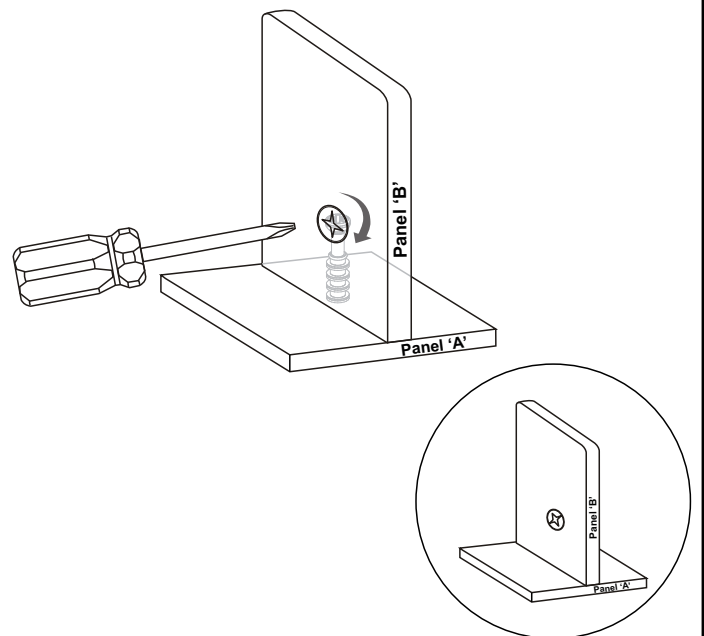

BEFORE YOU START THE ASSEMBLY, PLEASE READ THE FOLLOWING TIPS AND WARNINGS.

Do a quick inventory to make sure the package contains all the parts and hardware listed in the assembly instructions.



To avoid misalignments, always leave the screws loose and tighten them until all pieces are positioned correctly.

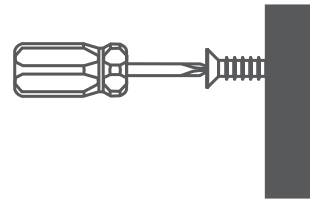

Missing, damaged and defective parts can be replaced at no cost to you. Please refer to the last pages on this manual.



Do not overtighten or force the screws as they might break, strip, damage the threads of the holes or get stuck inside the part.

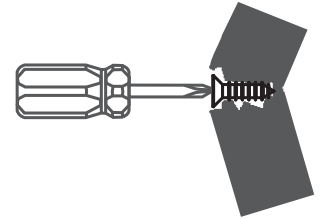

The replacement parts service is limited to the 48 contiguous United States. If you reside in Alaska, Hawaii, Puerto Rico, U.S. territories or other countries, please contact the supplier from where the unit was purchased.



Sometimes the laminate might cover partially or entirely the hole on a panel. If there is no visible hole for the screw, pass and press the tip of your finger over the area where the hole should be located to feel the indentation, and once found, carefully pierce the laminate to reveal the hole underneath.



If during assembly you find an issue or need clarification, please contact our Customer Service for assistance. Please refer to the last pages on this manual.



On each step read the instructions and analyze the illustrations thoroughly before proceeding to do the assembly.



If the hole seems too small for the screw, first make sure you are using the correct size of screw and that it's been installed in the correct hole. If the hole still appears to be too small, carefully pierce the laminate to reveal the hole's actual size.



Make sure you understand which hardware will be used on each step. Using the wrong size of screw, bolt or pin might strip the threads or cause damage to the part in which it is being used.

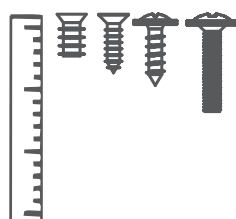

ASSEMBLY STEPS

STEP 1

Hardware/Tools

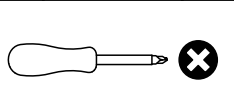
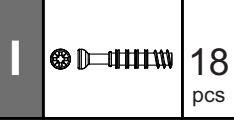

NOT INCLUDED:

Use a screwdriver (not included) to secure the cam bolt I into the indicate holes on panels 1, 2, 3 and 4.

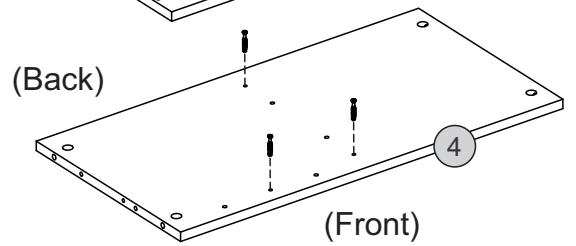
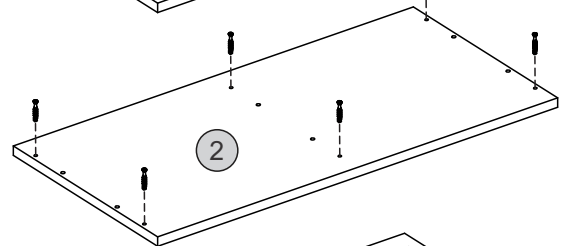
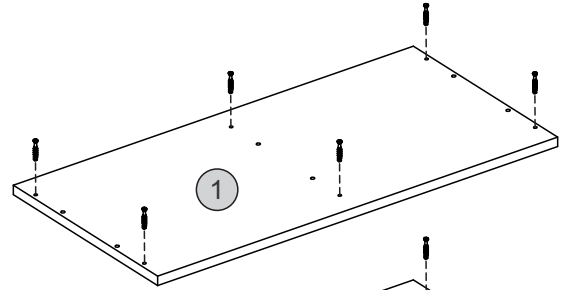
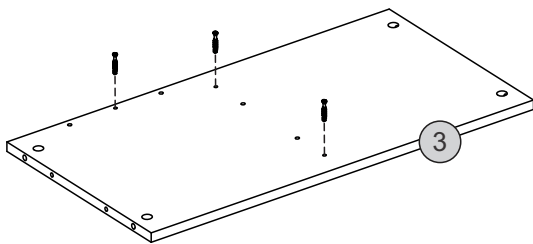
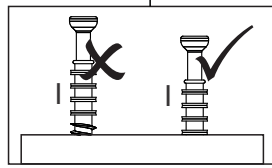
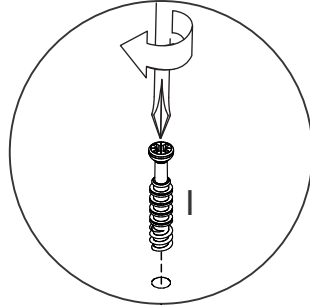

STEP 2

Hardware/Tools

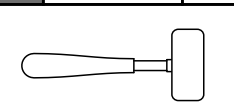

NOT INCLUDED:

Use a rubber mallet (not included) to insert the short dowels J into the indicates holes on panels 3, 4, 5, 8 and 9.

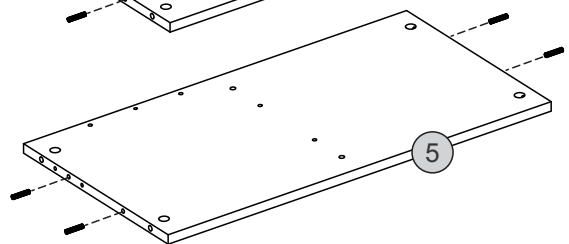
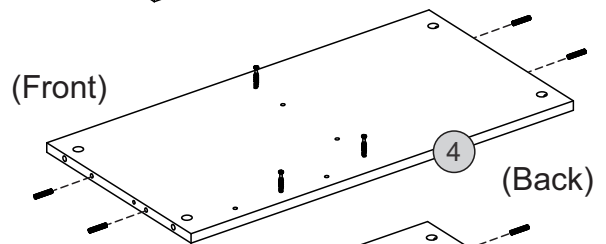
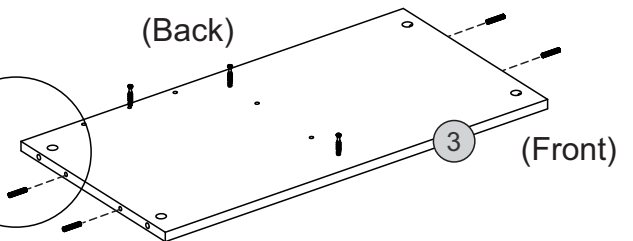
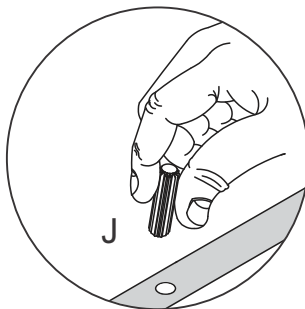

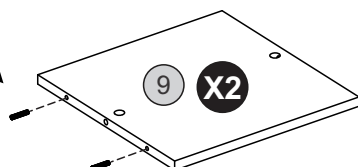
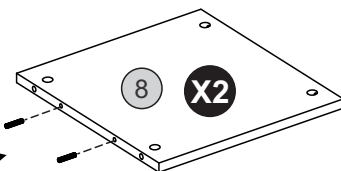

At 8 and 9, dowel on one side only!



STEP 3

Hardware/Tools

H		2 pcs
K		2 pcs
N		2 pcs

NOT INCLUDED:

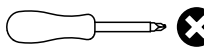
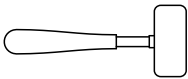

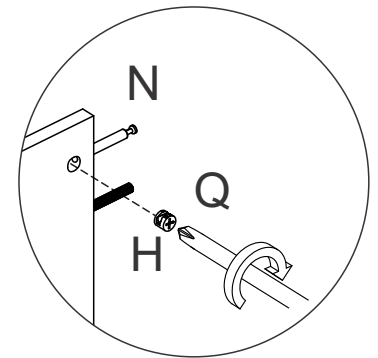
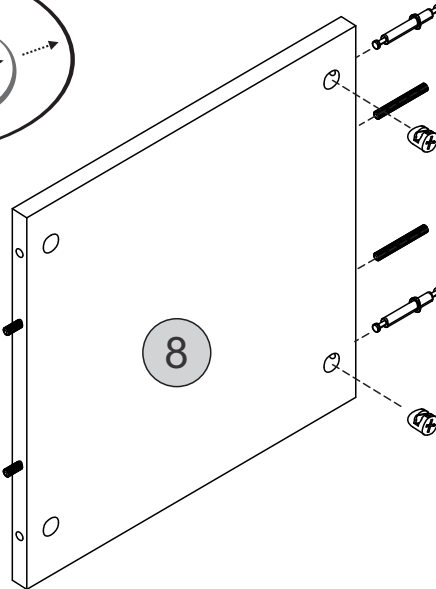
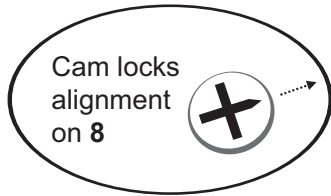

- Use a mallet (not included) to insert on one of the shelves **8** the long dowels **K** in the innermost holes as indicated.
- Then in the same panel insert the SHORT SIDE of the double cam locks **N** into the outermost holes and insert and turn the cam locks **H** to lock the bolts in place as shown.



STEP 4

Hardware/Tools

D		4 pcs
H		2 pcs

NOT INCLUDED:

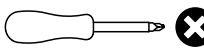



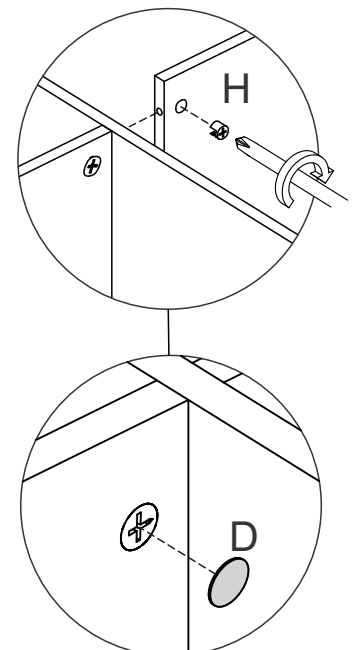
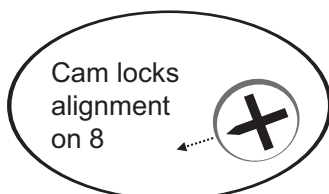
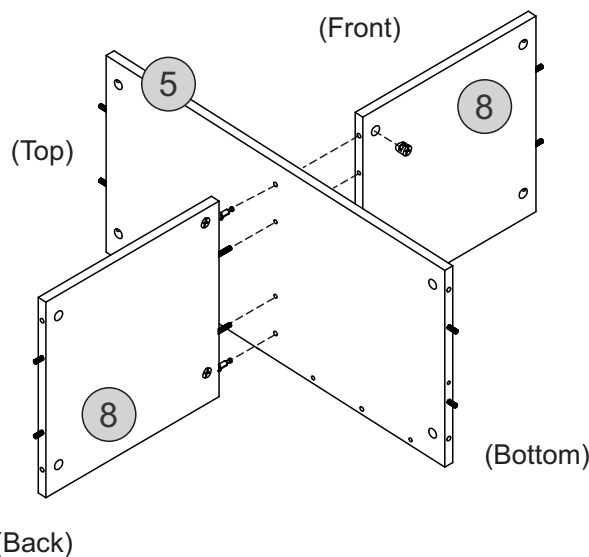

- Join the shelf **8** from step 3 to the division panel **5** making sure the bolts and dowels come out on the other side. Please note that the surface with cam locks must face towards the bottom.
- On the other side join the other shelf **8** to panel **5** and use cam locks **H** to secure the panel as shown and as explained in page **5**.
- Cover the cam locks with the stickers **D**. Do not use to cover empty holes.

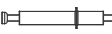

STEP 5

Hardware/Tools

D		2 pcs
H		2 pcs
N		1 pcs
Q		2 pcs

NOT INCLUDED:

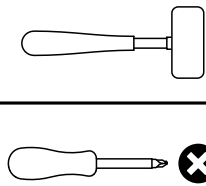

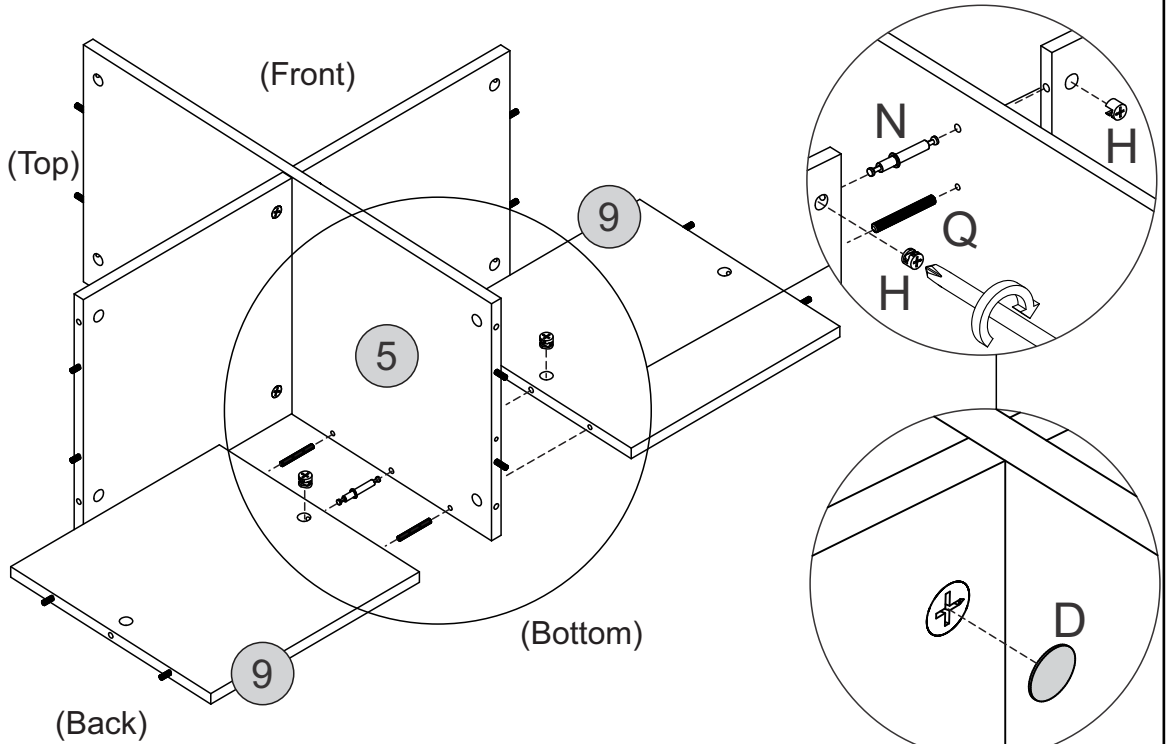

- Following the same procedures as in steps 3 and 4, use cam locks **H**, double bolts **N** and long dowels **K** to assemble the back panels **9** to panel **5** on each side at the bottom.
- Cover the cam locks with the stickers **D**. Do not use to cover empty holes.



STEP 6

Hardware/Tools

D		6 pcs
H		6 pcs

NOT INCLUDED:

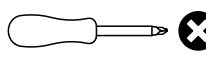

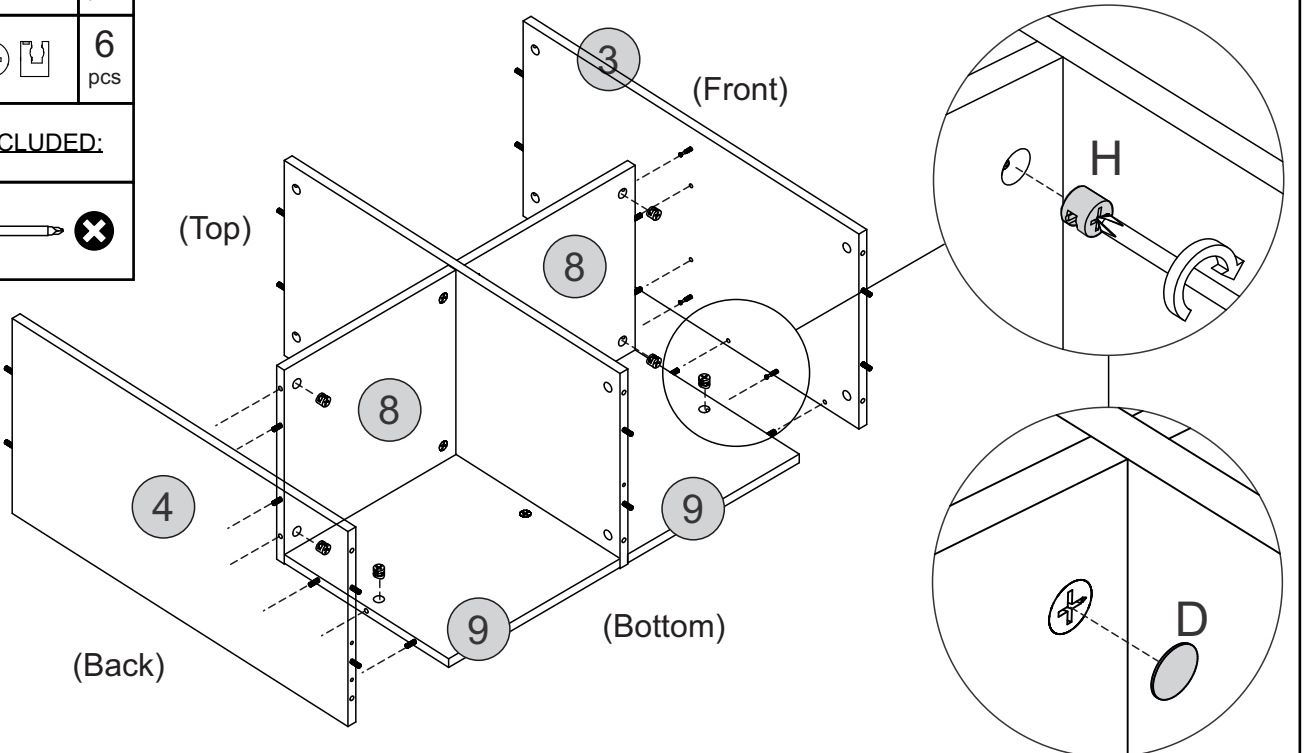

- Use a screwdriver (not included) to assemble the left and right side panels **3** and **4** to panels **8** and **9** on their respective sides with cam locks **H** as shown and as explained in page 5.
- Cover the cam locks with the stickers **D**. Do not use to cover empty holes.



STEP 7

Hardware/Tools

D		12 pcs
H		12 pcs

NOT INCLUDED:

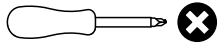

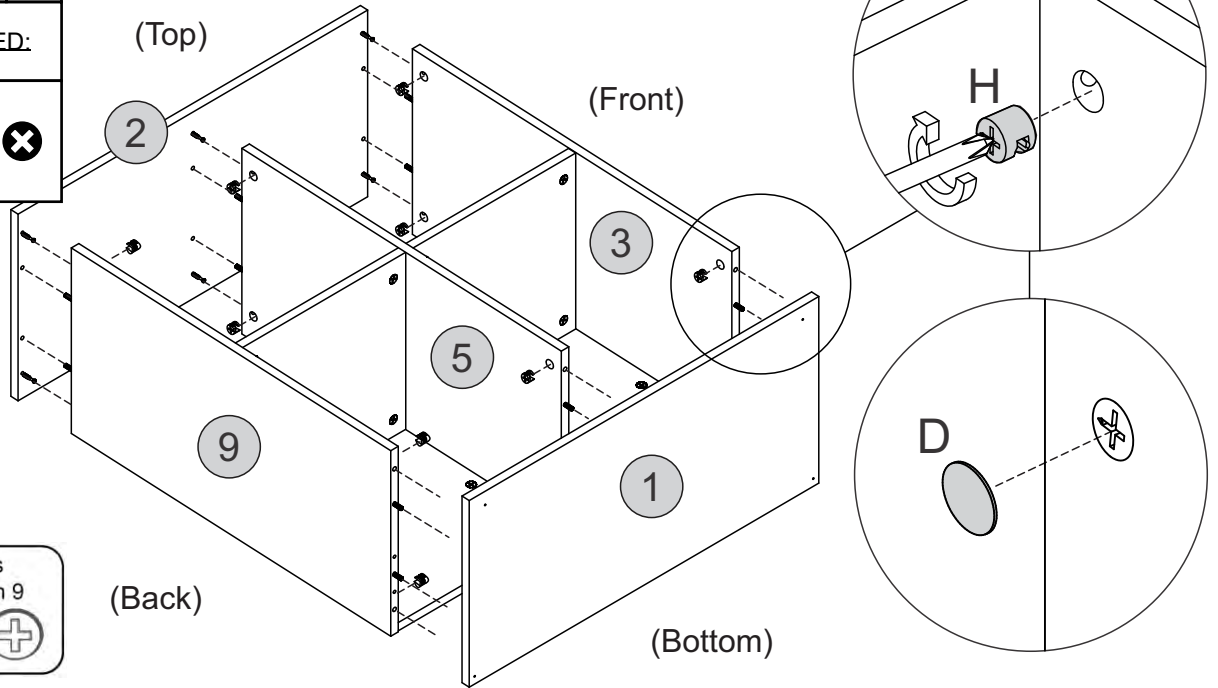

- Use a screwdriver (not included) to assemble the Bottom panel 1 and the Top panel 2 to panels 3, 5 and 9 with cam locks H as shown and as explained in page 5.
- Cover the cam locks with the stickers D.



STEP 8

Hardware/Tools

L		2 pcs
A		4 pcs

NOT INCLUDED:

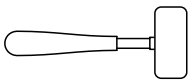

- Use a rubber mallet or hammer (not included) to insert the end caps L into the frames 6 and 7 at the indicated endings.
- Use a rubber mallet or hammer (not included) to attach the bottom glides A into the bottom holes of the frames 6 and 7.

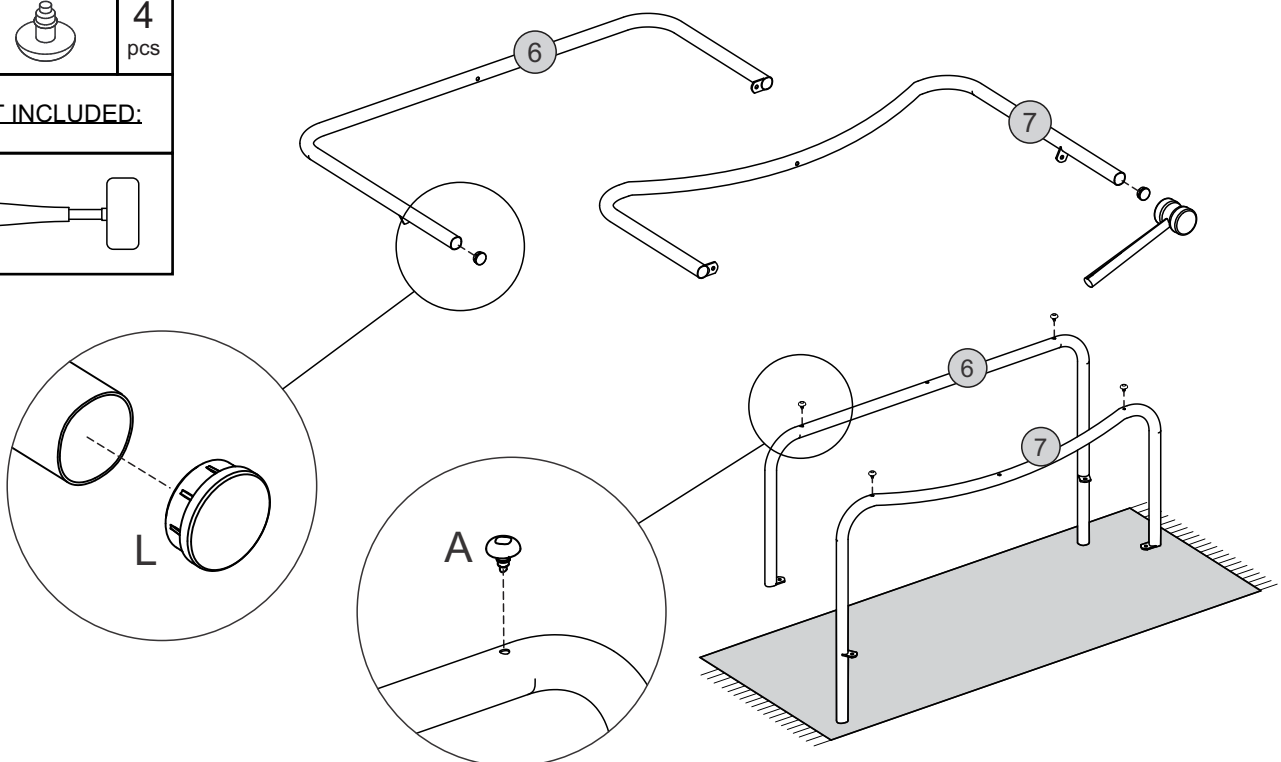

**PAY
ATTENTION !**

The frame 7 has this curved section as it goes OVER frame 6!

On both frames 6 and 7, the longer leg goes facing towards the **BACK** of the unit once assembled.

The frame 6 has this curved section as it goes UNDER frame 7!

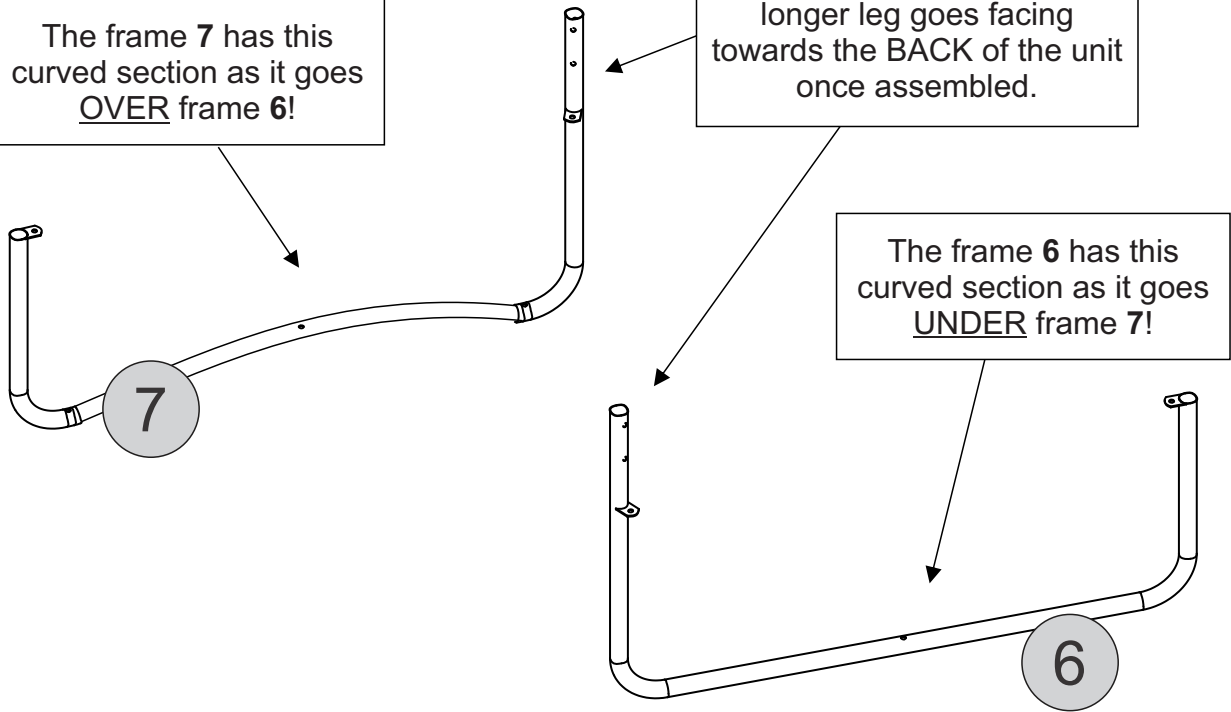

STEP 10

Hardware/Tools

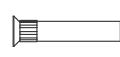
E		1 pcs
F		1 pcs

NOT INCLUDED:

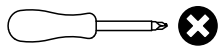

Use a screwdriver (not included) to secure the top frame 7 to the bottom frame 6 with screw **E** and the receptacle **F** as shown. Make sure the long legs of the frames are oriented on the same side towards the back.

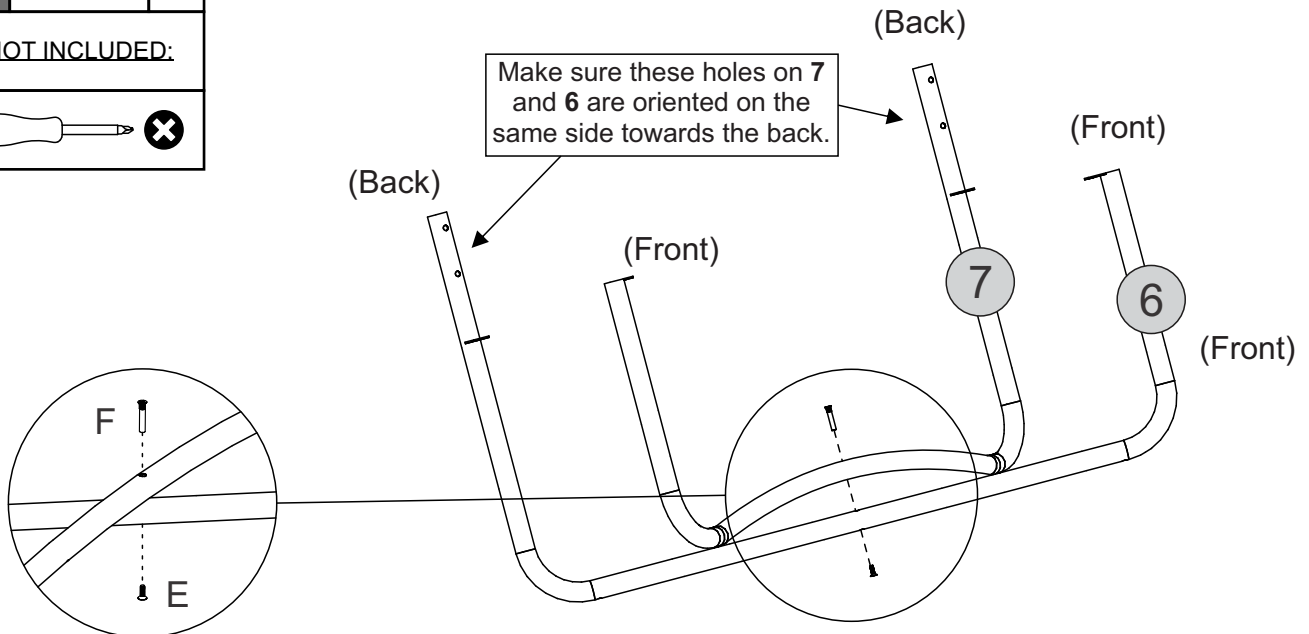

STEP 11

Hardware/Tools



NOT INCLUDED:

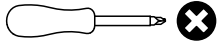

- Place the main unit upside-down over a blanket to protect its top finish.
- Use a screwdriver (not included) to assemble the leg frames **6** and **7** to the bottom panel **2** screws **G**, making sure the long legs go towards the back as shown.

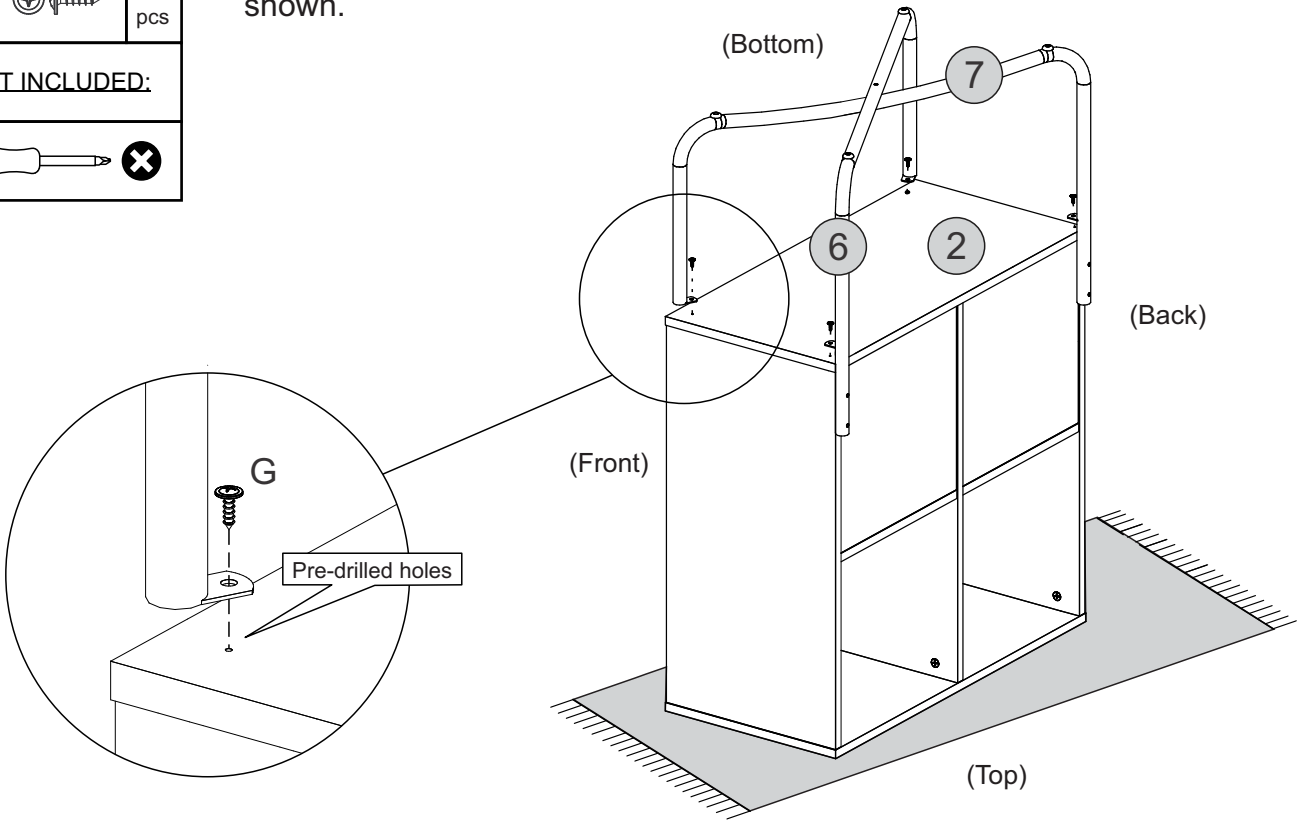

STEP 12

Hardware/Tools

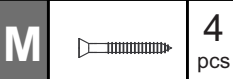

NOT INCLUDED:

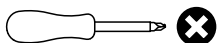

Use a screwdriver (not included) to secure **7** and **6** to the side panels **3** and **4** with screws **M** as shown.

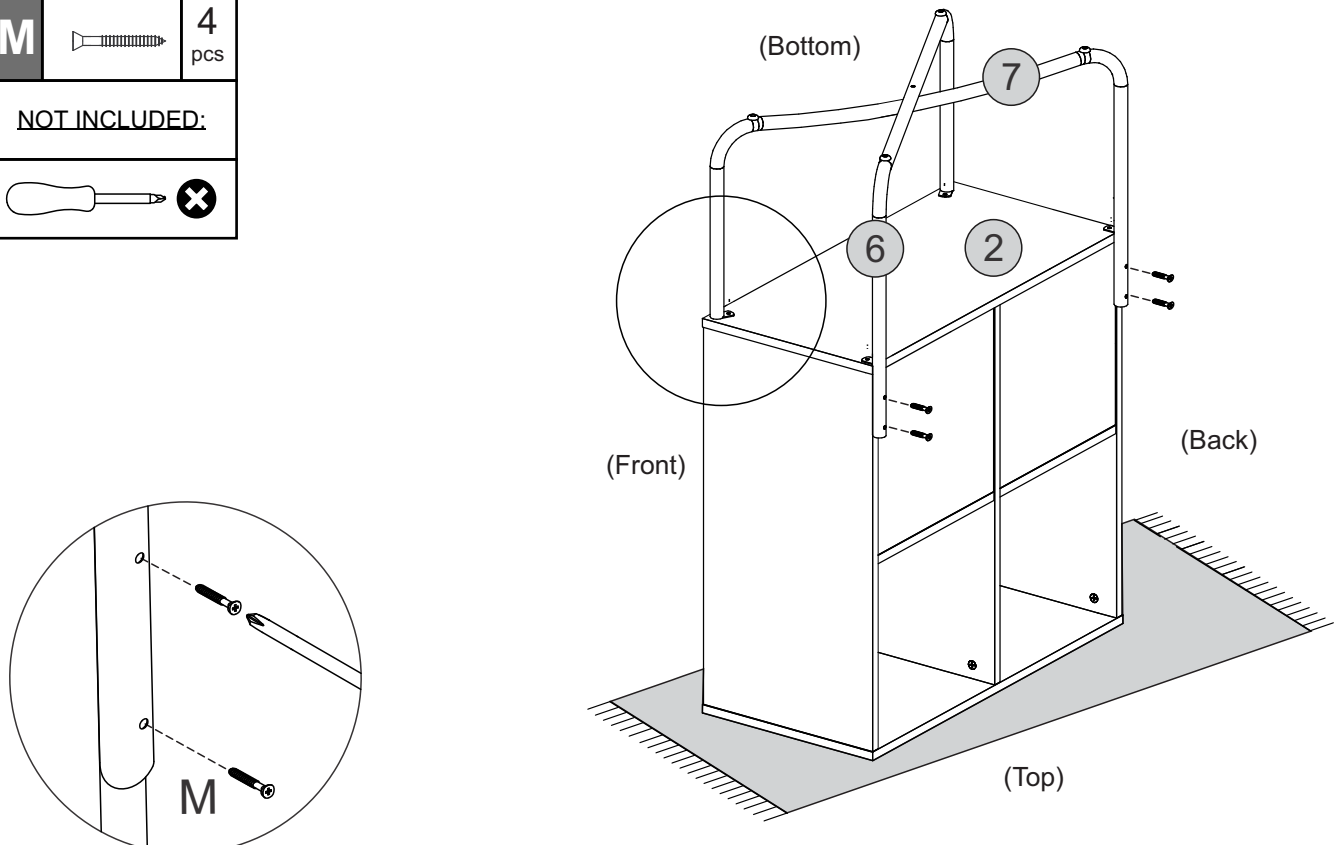

TIP OVER WARNING

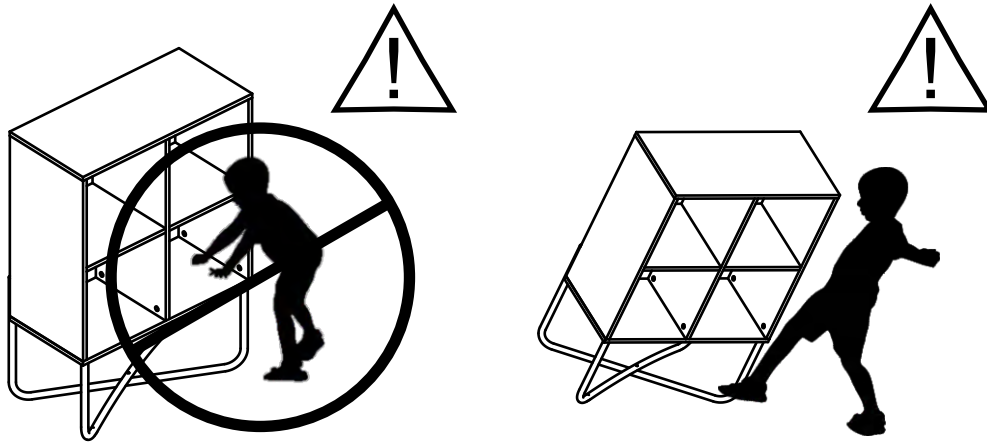

PREVENT TIP-OVER ACCIDENTS BY FOLLOWING THESE RECOMMENDATIONS:

- 1) Secure the unit by anchoring it to the wall. The anchoring device has been provided with the unit, and must be installed by following the instructions shown on the next steps 12 and 13 on PAGES 13 and 14.
- 2) Once the unit has been anchored, load the heavier objects onto the lower shelves, and the lighter objects to the upper shelves.
- 3) Never reach the objects on the upper shelves by climbing on the lower shelves.
- 4) Do not let children climb or play inside any of the shelves.

STEP 13

Hardware/Tools

O		2 pcs
P		2 pcs
Q		2 pcs

NOT INCLUDED:

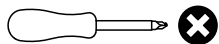

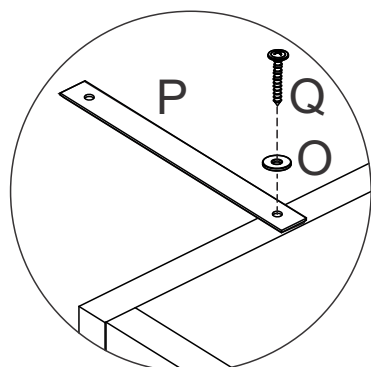
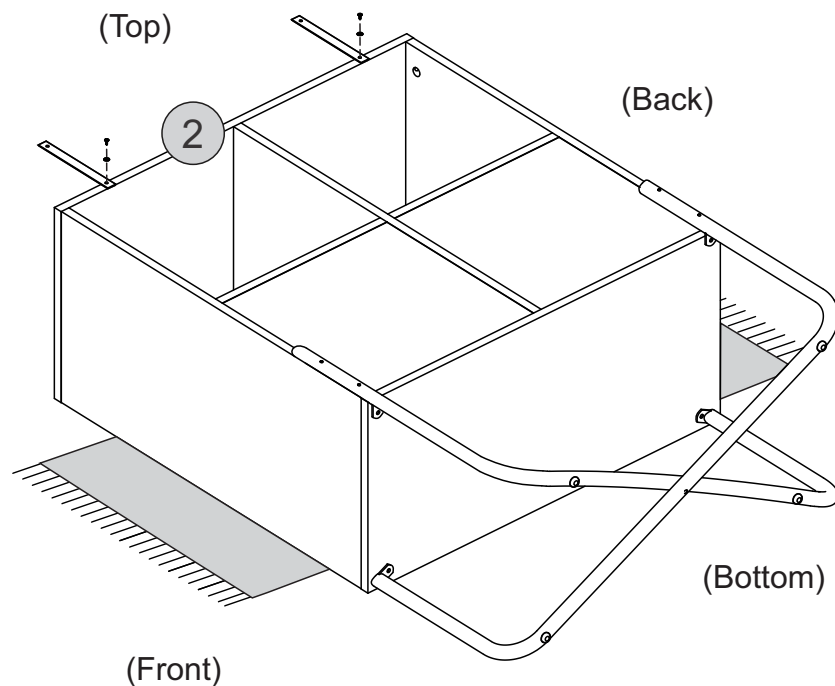

Use a screwdriver (not included) to attach the straps **P** to the back of the top panel **2** with screws **Q** and washers **O**.



STEP 14

Hardware/Tools

B		2 pcs
C		2 pcs
O		2 pcs

NOT INCLUDED:

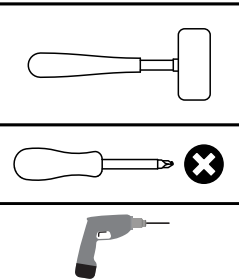

- Place the unit in the desired location against the wall.
- Use a pencil (not included) to mark the 2 points on the wall where the unit will be anchored.
- Use a power driller with Ø6mm drill bit (not included) to drill the holes on the wall at the marks.
- Use a mallet or hammer (not included) to insert the anchor **N** in the holes on the wall.
- Use a screwdriver (not included) to secure the straps **M** to the anchors **N** with screws **K** as shown.

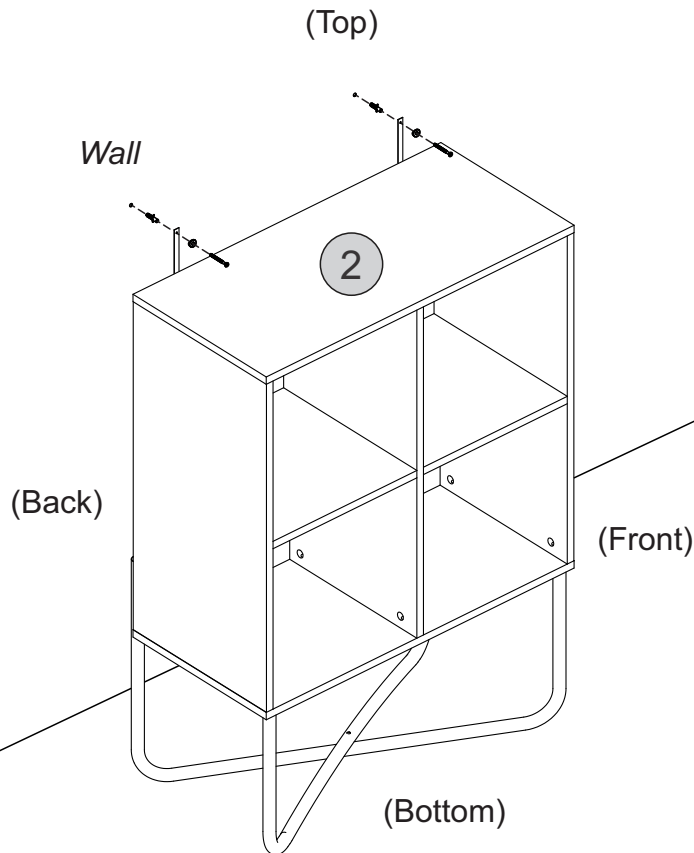

1. Mark the wall

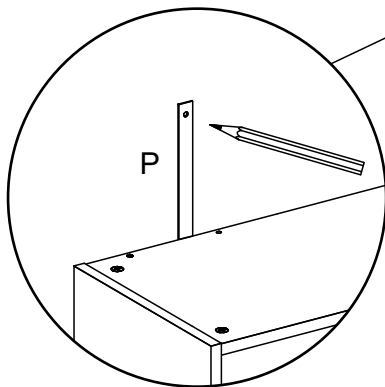

2. Drill the holes

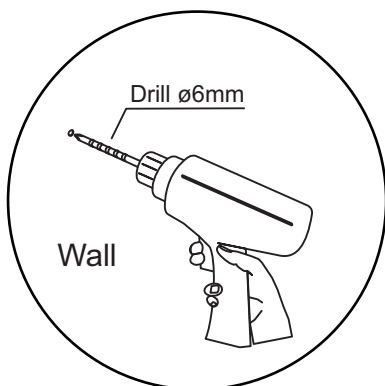

3. Insert the anchors

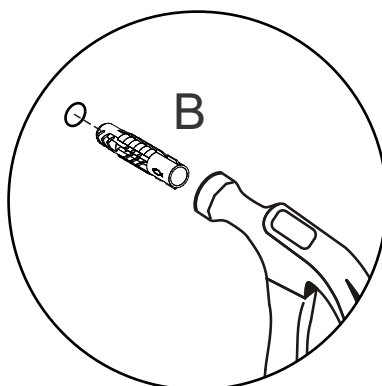

4. Secure the straps

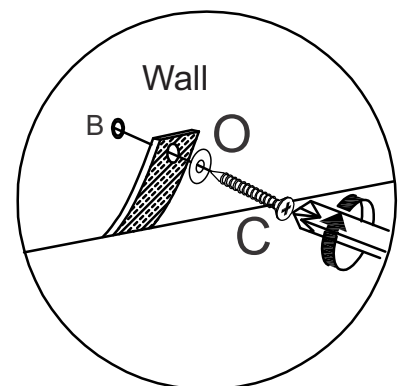



ALL DONE!

Give yourself a nice pat on the back. You did a great job!

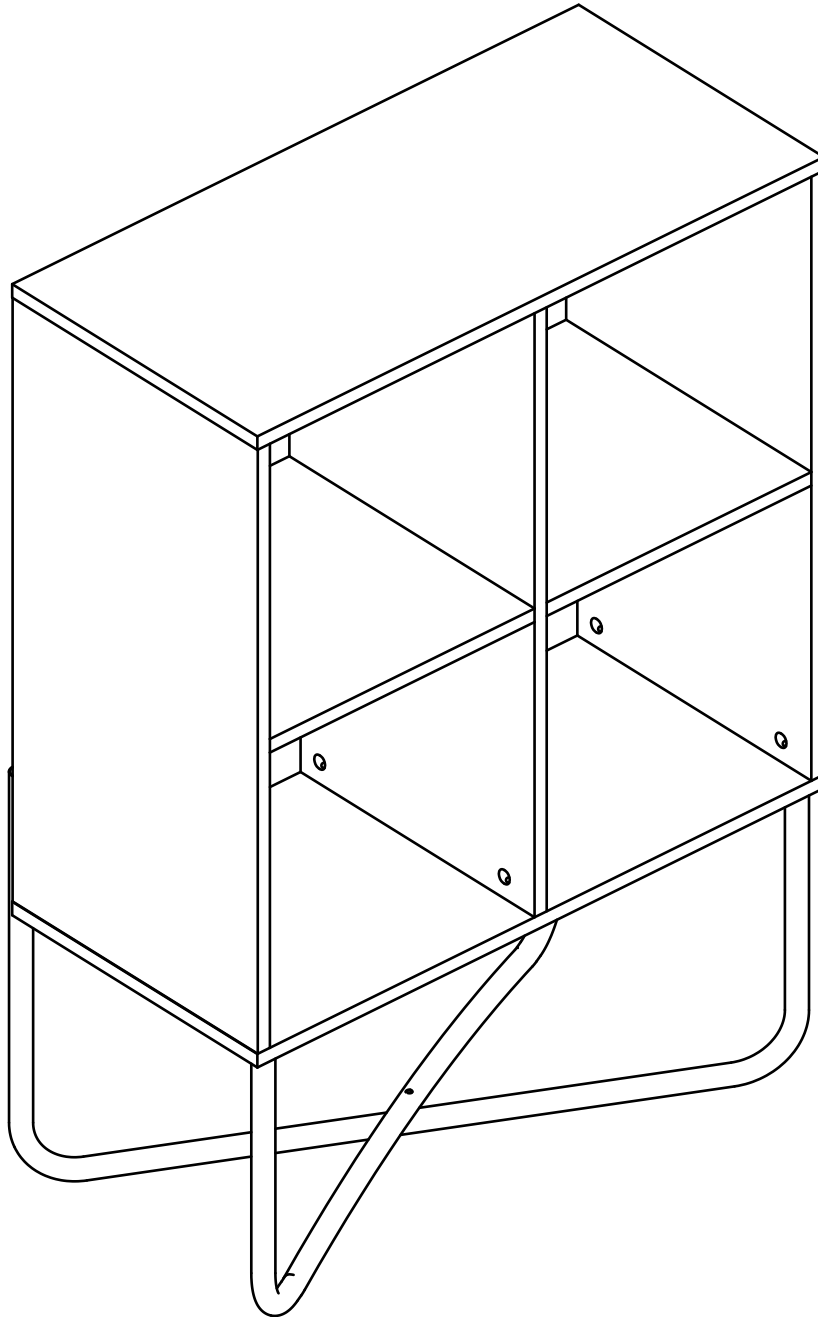

If desired, after assembly use an alcohol cleaner to erase the number printed on the parts.

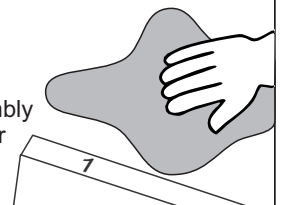

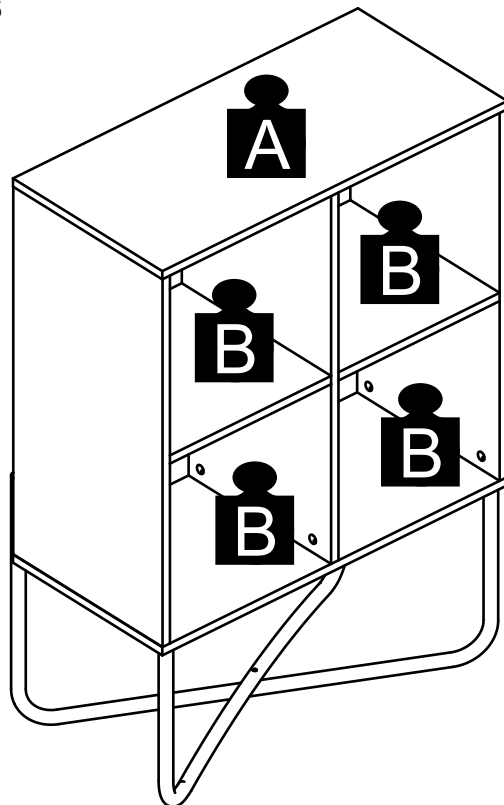
CARE, MAINTENANCE AND SAFETY WARNINGS:**WEIGHT LIMITS**

A = 22 Lbs. (10 Kg)

B = 11 Lbs. (5 Kg)

- Do not exceed the indicated weight limits.
- Secure the unit to the wall with the anchoring device provided with the product.
- Do not expose the surfaces to direct sunlight or to extreme environmental conditions.
- Clean the surfaces preferable with a clean cloth damped in a solution of mild soap and water, then dry with a clean towel.
- Do not use solvents or abrasive materials to clean the unit.
- If you decide to use a cleaning agent, test first on an area hidden from view such as underneath the top or shelves.
- Load the heavier objects onto the lower shelves, and the lighter objects to the upper shelves.
- Do not allow small children to climb over the unit or play inside the shelves.
- Do not allow small children reaching onto the top shelves by themselves, as objects might fall and hurt them.
- Always remove all objects before removing and re-locating the unit somewhere else.
- Shall any part of the unit become defective during the warranty period, replacement parts might be available to you at no charge. Please refer to the last pages on this manual.
- The warranty does not extend to regular wear and tear, nor the manufacturer assumes liability for damages or consequences due to accidents, incorrect assembly, negligence, improper use, modifications, or not heeding the above warnings.

TECHNI MOBILI DESK WARRANTY

DESKS/LAPTOP CARTS/FILE CABINETS: LIMITED 5-YEAR WARRANTY

RTA Products, LLC warrants to the Original Purchaser who acquired a new product from RTA Products or its authorized resellers that this product will be free from defects in its workmanship and materials, under normal use and service conditions, as described herein. "Defects" as used in this warranty, is defined as any imperfections that impair the use of the furniture or product. RTA Products LLC will replace any defective part, at its discretion, and without charge to the original purchaser other than the freight from the end consumer to RTA Products.

Replacement parts can only be supplied if parts are available. Items out of production may be unavailable. This warranty will be effective for the applicable time period beginning the date of purchase on your original sales receipt. RTA product's obligation under this warranty is limited to repairing or replacing products or parts as provided herein. This product has been designed for and is intended for office and home-office use only. This warranty is Original Purchaser's sole remedy for product defects, and this warranty does not extend to any product, or damage to any product, caused by or attributed to abuse or misuse, products used for commercial or rental purposes, use modifications of, or attachments to the product, and products or parts not used, maintained, or extended hereunder is in lieu of any and all other warranties, express or implied, including without limitations any implied warranty or merchantability or of fitness for a particular purpose. Please note, all desks made with PVC Laminate surface should not be exposed to direct sunlight, as it may damage the material. Damage of this nature is not covered under this warranty.

RTA Products will not be responsible for indirect, special, incidental or consequential damages. This warranty is limited to merchandise purchased in the Continental United States, excludes AK, HI and PR. Some States do not allow the exclusion or limitation of incidental or consequential damages, so the above limitations or exclusions may not apply to you. This warranty gives you specific legal rights. You may also have other rights that may vary from state to state.

RTA Products will advise you of the procedure to follow in making warranty claims. The following are the procedures for warranty claims:

- a. Call us Monday –Friday, from 9am-5pm (Eastern Time) at (866) 782-5520 to explain the defect and give your name, address and phone number. Please have ready the model number of our product, date and place of purchase. You can also write to us by e-mail to warranty@rtaproducts.com and include the same information.
- b. If we determine that replacement will remedy the situation, and in order to determine the extent or the cause of the defect, purchaser will need to send the part in question at purchaser's expense. Once we receive the part, we will examine it and determine whether the claim is valid (or not), and then proceed to send the replacement. We will ship the replacement at our expense.

FOR SEVERAL HELP OPTIONS INCLUDING REPLACEMENT PARTS ORDERS

VISIT: WWW.TECHNIMOBILI.COM



CLICK ON SUPPORT TAB



Scan QR Code to order replacement parts

OR EMAIL US: SUPPORT@RTAPRODUCTS.COM

