

# MODEL RTA-982C

## ASSEMBLY INSTRUCTIONS

Thank you for purchasing our product.

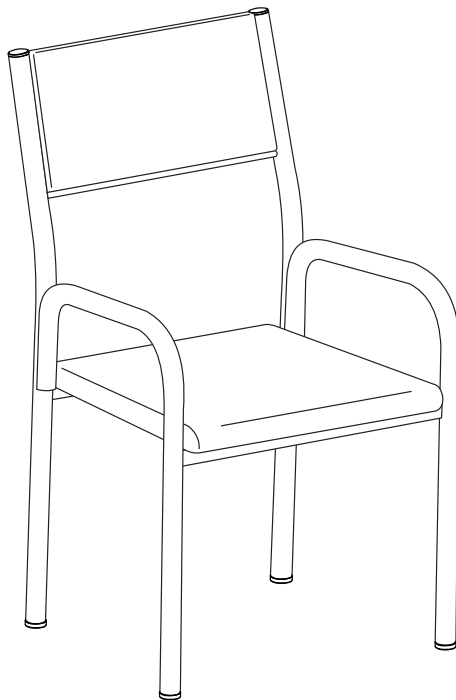

REV.CAR-6643-0622-0





- Please read carefully the assembly instructions before the installation.



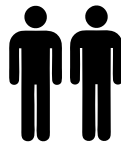

- Do not discard this manual or any of the packaging material until the unit has been completely assembled.





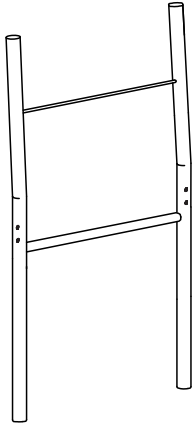

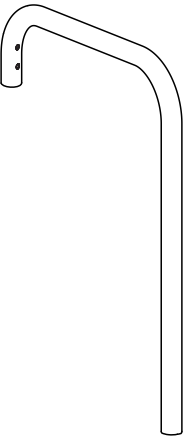
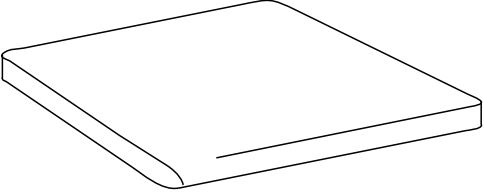
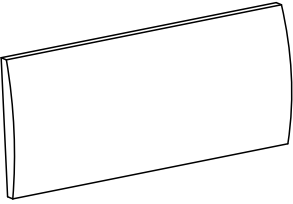

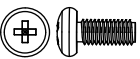

- Might require two people.

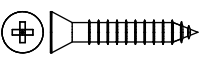
**MAIN PARTS LIST**

<p><b>1</b> x1</p> <p>Back legs</p> 	<p><b>2</b> x1</p> <p>Crossbar</p> 	<p><b>3</b> x2</p> <p>Front legs</p> 
<p><b>4</b> x1</p> <p>Seat</p> 	<p><b>5</b> x1</p> <p>Backrest</p> 	

**LIST OF HARDWARE**

PART	QTY	ITEM	
A	4	M4x12	
B	4	4x14	
C	4	4x35	
D	2	7x50	
E	2	20x20	
F	1	21x47	
H	2	23x12	
I	4	23x23	

**MAIN PARTS LAYOUT (FOR REFERENCE)**

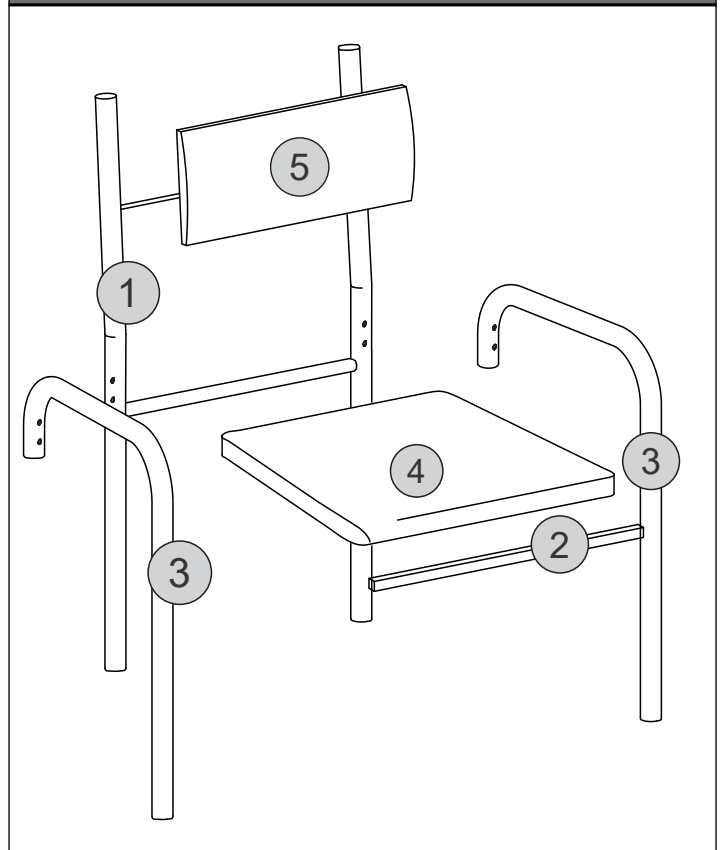

You will also need for the assembly a Phillips screwdriver and rubber mallet (not included).

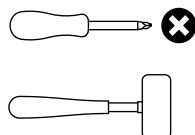

**BEFORE YOU START THE ASSEMBLY, PLEASE READ THE FOLLOWING TIPS AND WARNINGS.**

Do a quick inventory to make sure the package contains all the parts and hardware listed in the assembly instructions.



To avoid misalignments, always leave the screws loose and tighten them until all pieces are positioned correctly.

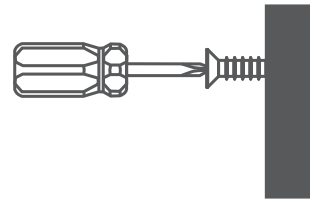

Missing, damaged and defective parts can be replaced at no cost to you. Please refer to the last pages on this manual.



Do not overtighten or force the screws as they might break, strip, damage the threads of the holes or get stuck inside the part.

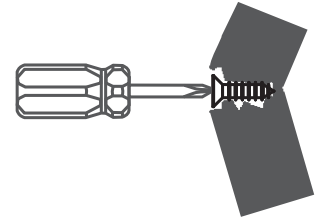

The replacement parts service is limited to the 48 contiguous United States. If you reside in Alaska, Hawaii, Puerto Rico, U.S. territories or other countries, please contact the supplier from where the unit was purchased.



Sometimes the laminate might cover partially or entirely the hole on a panel. If there is no visible hole for the screw, pass and press the tip of your finger over the area where the hole should be located to feel the indentation, and once found, carefully pierce the laminate to reveal the hole underneath.



If during assembly you find an issue or need clarification, please contact our Customer Service for assistance. Please refer to the last pages on this manual.



On each step read the instructions and analyze the illustrations thoroughly before proceeding to do the assembly.



If the hole seems too small for the screw, first make sure you are using the correct size of screw and that it's been installed in the correct hole. If the hole still appears to be too small, carefully pierce the laminate to reveal the hole's actual size.



Make sure you understand which hardware will be used on each step. Using the wrong size of screw, bolt or pin might strip the threads or cause damage to the part in which it is being used.

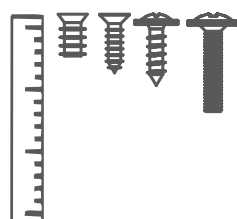



ASSEMBLY STEPS

STEP 1

Use a rubber mallet (not included) to insert the top end round caps **H**, and the bottom round glides **I** into the back legs **1**.

Hardware/Tools

<b>H</b>	 23x12	2 pcs
<b>I</b>	 23x23	2 pcs

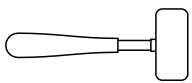

NOT INCLUDED

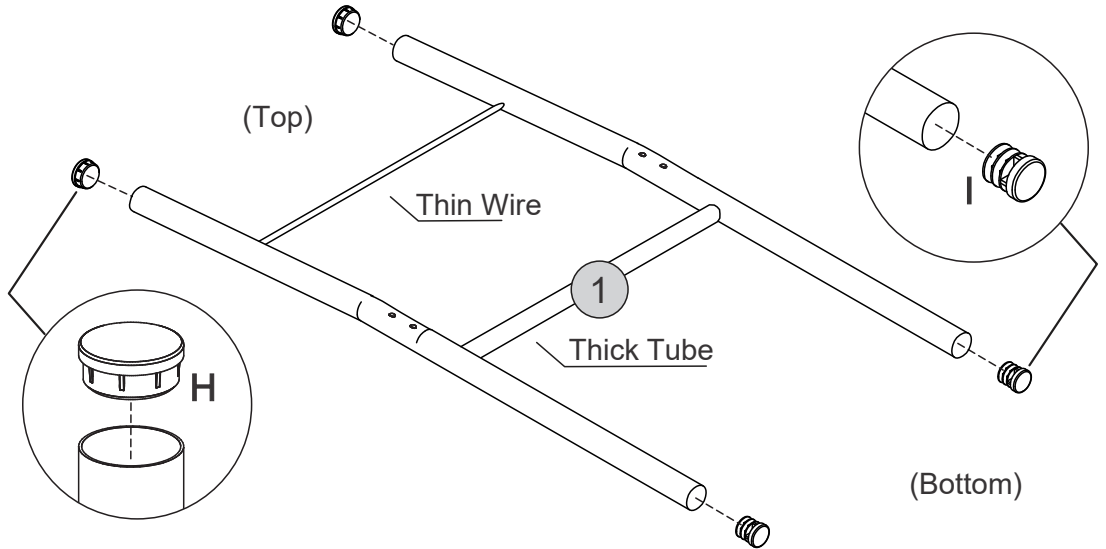

STEP 2

Use a rubber mallet (not included) to insert the square end caps **E** into each end of the crossbar **2**.

Hardware/Tools

<b>E</b>	 20X20	2 pcs
----------	--	----------

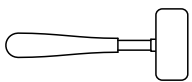

NOT INCLUDED

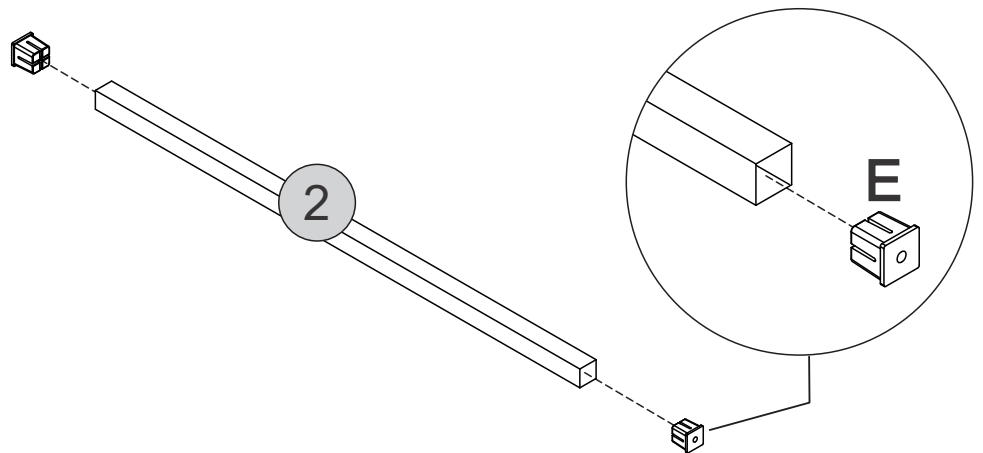

STEP 3

Use a rubber mallet (not included) to insert the bottom round glides **I** into the front legs **3**.

Hardware/Tools

<b>I</b>	 23x23	2 pcs
----------	--	----------

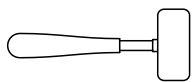

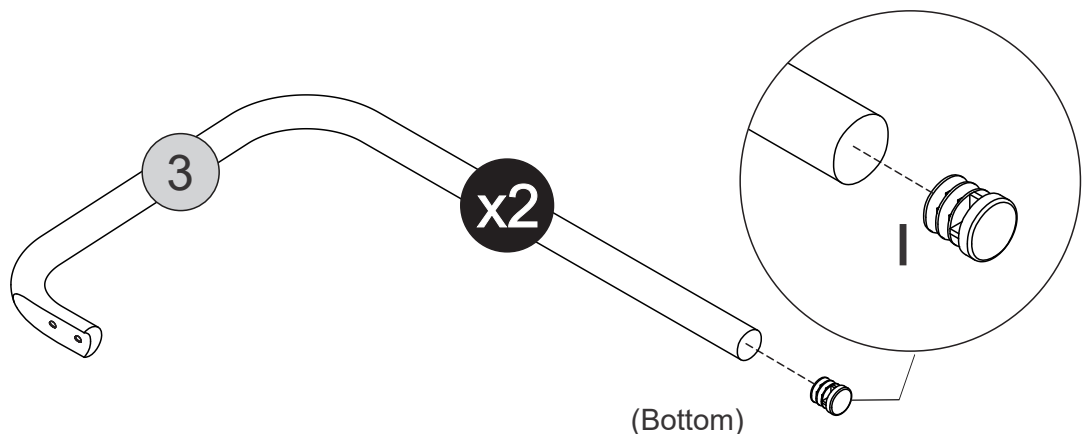

NOT INCLUDED



**STEP 4**

**Hardware/Tools**

<b>D</b>	 7x50	2 pcs
<b>F</b>		1 pc

Use the Allen key **F** to assemble the crossbar **2** in between the front legs **3** with screws **D**, but make sure the holes on the crossbar face **UP** as shown.

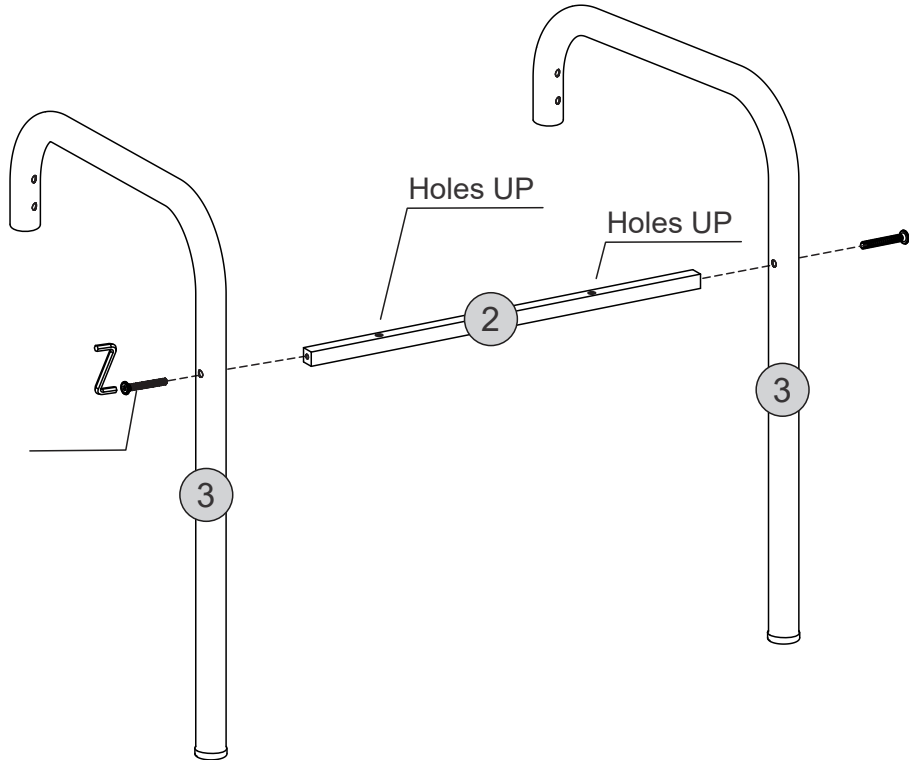
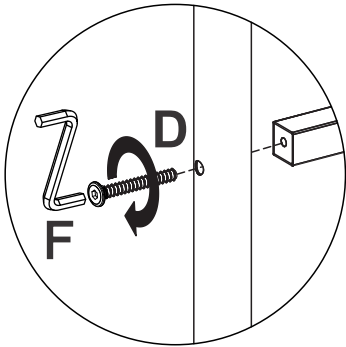

**STEP 5**

**Hardware/Tools**

<b>A</b>	 M4x12	4 pcs
----------	--	----------

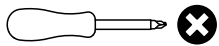

NOT INCLUDED

Use a screwdriver (not included) to assemble the front legs **3** to the back legs **1** with the screws **A**.

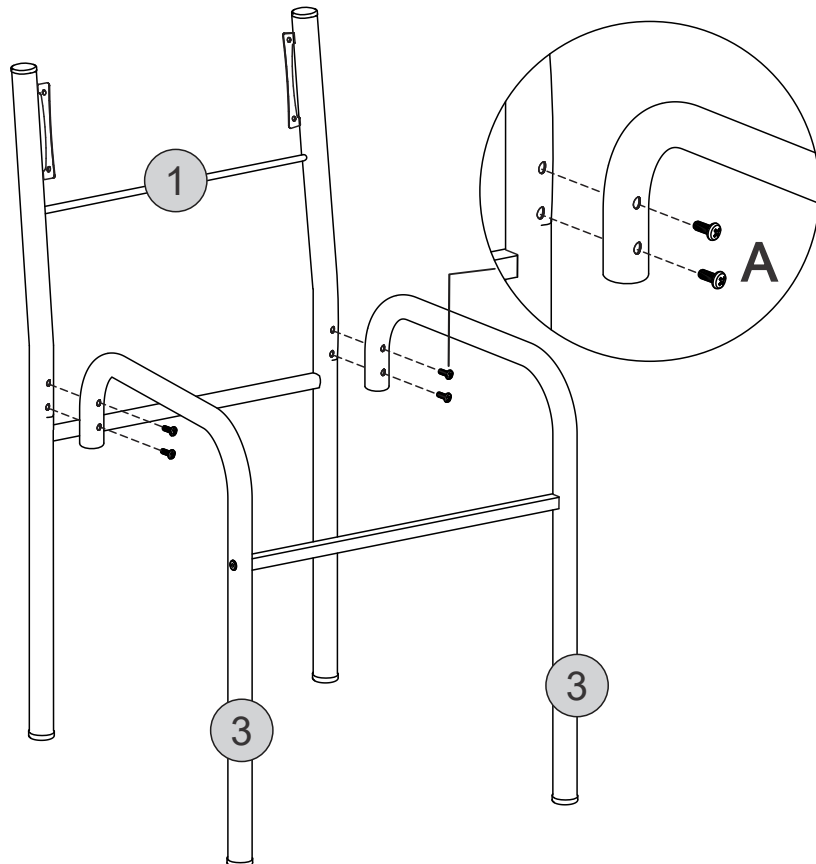

**STEP 6**

**Hardware/Tools**

**B**  **4**  
4x14 pcs



**NOT INCLUDED**

Use a screwdriver (not included) to assemble the backrest **5** to the back legs **1** with screws **B**.

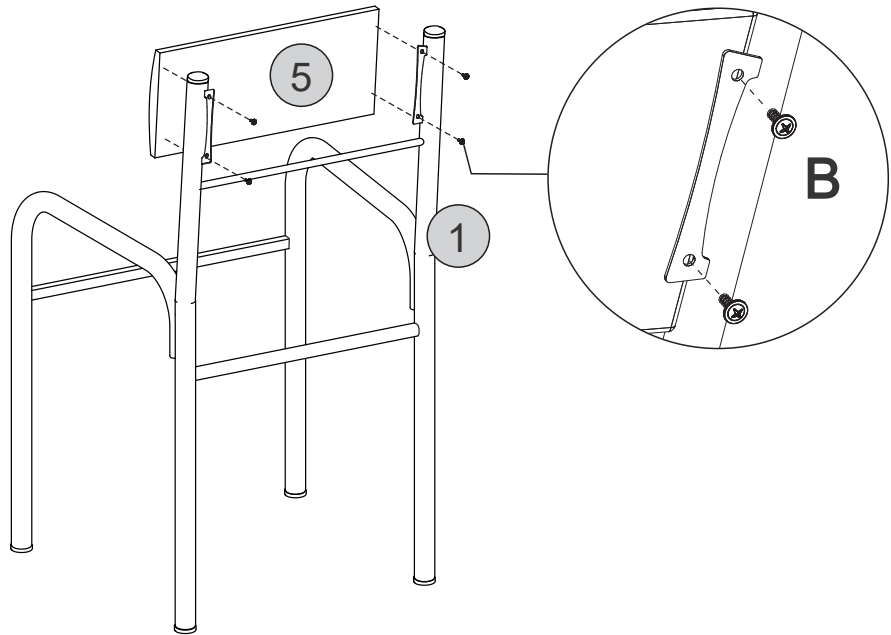

**STEP 7**

**Hardware/Tools**

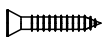
**C**  **4**  
4x35 pcs

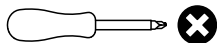

**NOT INCLUDED**

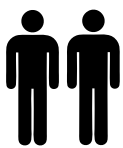

- Place the chair turned over on a table with soft cloths under the armrests of the front legs to protect their finish.
- With the help of another person holding the seat **4**, assemble it to the crossbar **2** and the cross tube on the back legs **1** with screws **C** as shown.

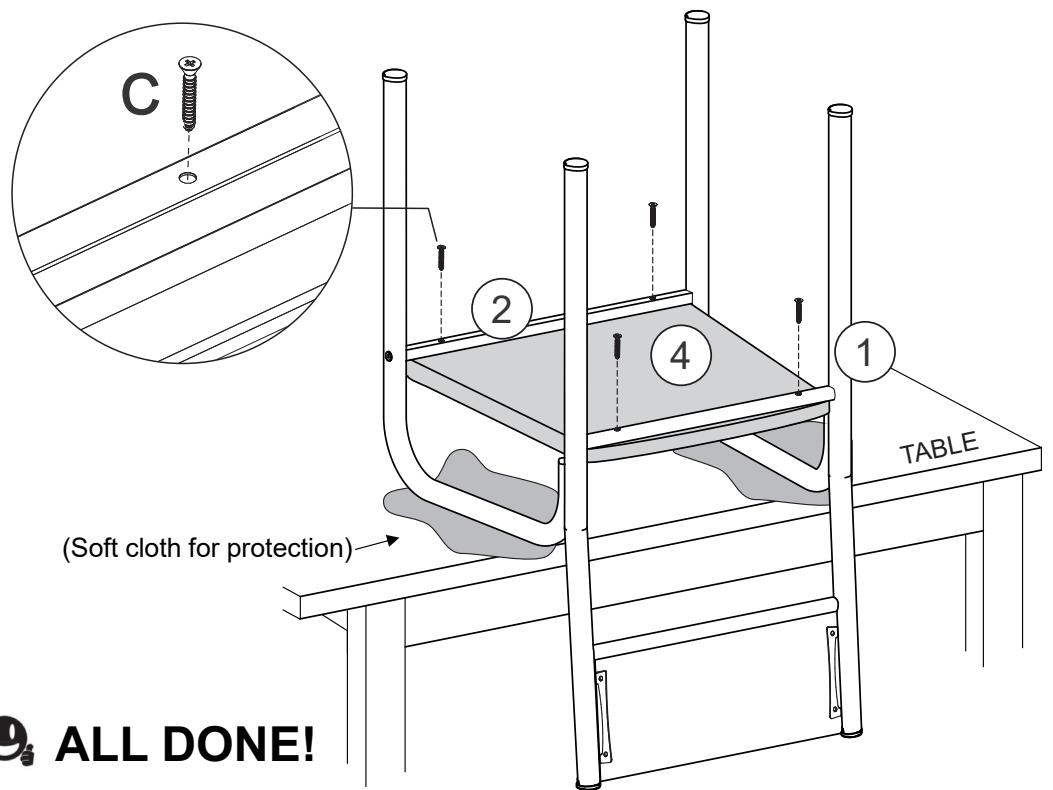

(Soft cloth for protection) →

 **ALL DONE!**

Give yourself a nice pat on the back.  
You did a great job!

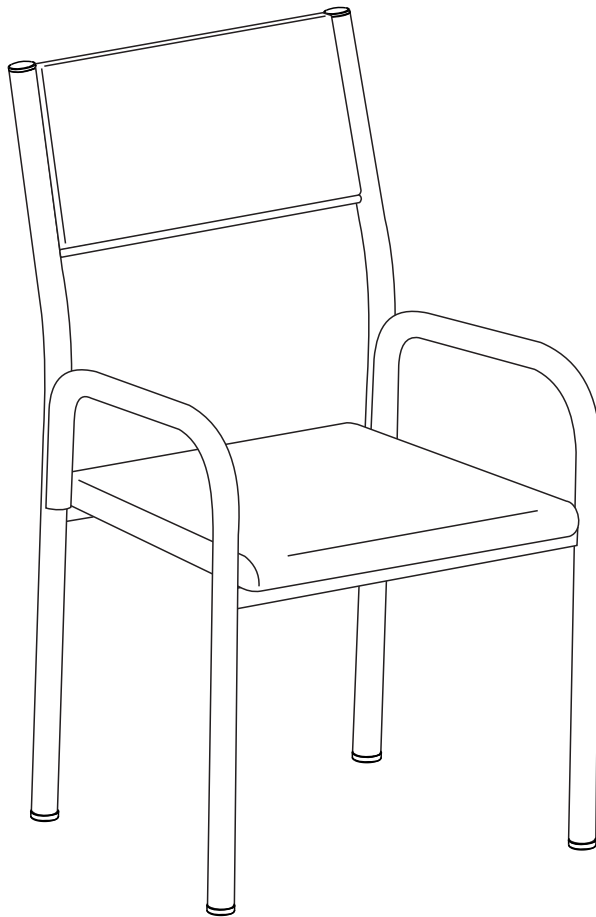

**WARNINGS**

- Do not exceed the indicated weight limit.
- Do not stand up on the chair or use it as ladder.
- Only one person at a time can sit on the chair.
- Do not use the chair if parts are damaged or if screws are loose or missing.
- Do not sit near the edge of the seat to avoid going beyond your balance point and falling off the chair, and always sit properly.
- If small children are sitting on the chair, please keep close observation on them.
- Do not allow small children to play with the chair.
- Not paying attention to these warnings could result in injuries.

**CARE AND MAINTENANCE**

- To clean the chair it is recommended to use a soft cloth lightly damped in a solution of smooth soap and water, then dry with a clean towel.
- Do not use solvents or abrasive materials to clean any part of the chair.
- Before using a cleaning agent, test on a small hidden area of the chair, like underneath the seat.
- Do not expose the product to direct sunlight or to extreme environmental conditions.
- Every 4 months, inspect the chair completely and make sure that all screws are tighten.



## TECHNI MOBILI CHAIR WARRANTY

### **TASK/KID'S/DINING/VISITOR'S CHAIR: 1-YEAR WARRANTY EXECUTIVE/MANAGER/GAMING CHAIR: 2-YEAR WARRANTY**

1. RTA Products, LLC has warranted the Techni Mobili office chairs to the original purchaser who acquired a new product from RTA Products or its authorized resellers of the product against defects in material or workmanship.
2. This warranty is expressly limited to the repair or replacement (at its option) of defective chair components or materials that fails under normal use as a result of a defect in materials or workmanship. This warranty is limited to merchandise purchased in the Continental United States, excludes AK, HI and PR. No assembly labor is included. The word "defects" as used in this warranty, is defined as imperfections that impair the utility of the product.
3. This warranty applies under conditions of normal use, but does not apply to defects that result from intentional damage, negligence, unreasonable use or exposure.
4. Liability for consequential damages is excluded to the extent exclusion is permitted by law. This warranty gives you specific legal rights, and you may have other rights that vary from State to State.
5. RTA Products does not warrant: a) natural variations in character marks b) changes in surface finishes due to aging or exposure to light c) marks, scars, or wrinkles occurring naturally in leather d) failure resulting from normal wear and tear e) the matching of colors, grains, or textures of natural materials f) the colorfastness or the matching of textiles, including an exact match to cuttings or to swatch cards g) damage, marking, or staining of veneer surfaces due to contact with rubber or similar compounds, damage from sharp objects or imprinting from writing instruments, or prolonged exposure to direct sunlight h) we do not warrant products that are exposed to extreme environmental conditions or that have been subject to improper storage.
6. RTA Products shall not be liable for loss of time, inconvenience, commercial loss, or incidental or consequential damages.
7. Any modification to the original product voids the warranty. We do not warrant the performance of the product when used in combination with other than original products.
8. This product has been designed for and is intended for office and home-office use only. This warranty is Original Purchaser's sole remedy for product defects, and this warranty does not extend to any product, or damage to any product, caused by or attributed to abuse or misuse, products used for commercial or rental purposes, use modifications of, or attachments to the product, and products or parts not used, maintained, or extended hereunder is in lieu of any and all other warranties, express or implied, including without limitations any implied warranty or merchantability or of fitness for a particular purpose.
9. Report any defects to RTA Products, LLC together with your sales receipt or other proof of purchase. If the chair is defective within the terms of the warranty, RTA Products, LLC will furnish a replacement chair (at its option) at no cost of equal or similar value and design.
10. RTA Products will advise you of the procedure to follow in making warranty claims. The following are the procedures for warranty claims:
  - a) Call us Monday – Friday, from 9am-5pm (Eastern Time) at (866) 782-5520 to explain the defect and give your name, address and phone number. Please have ready the model number of our product, date and place of purchase. You can also write to us by e-mail to [warranty@rtaproducts.com](mailto:warranty@rtaproducts.com) and include the same information.
  - b) If we determine that replacement will remedy the situation, and in order to determine the extent or the cause of the defect, purchaser will need to send the part in question at purchaser's expense. Once we receive the part, we will examine it and determine whether the claim is valid (or not), and then proceed to send the replacement. We will ship the replacement at our expense.

# FOR SEVERAL HELP OPTIONS INCLUDING REPLACEMENT PARTS ORDERS

---

VISIT: [WWW.TECHNIMOBILI.COM](http://WWW.TECHNIMOBILI.COM)



CLICK ON SUPPORT TAB



Scan QR Code to order replacement parts

OR EMAIL US: [SUPPORT@RTAPRODUCTS.COM](mailto:SUPPORT@RTAPRODUCTS.COM)