

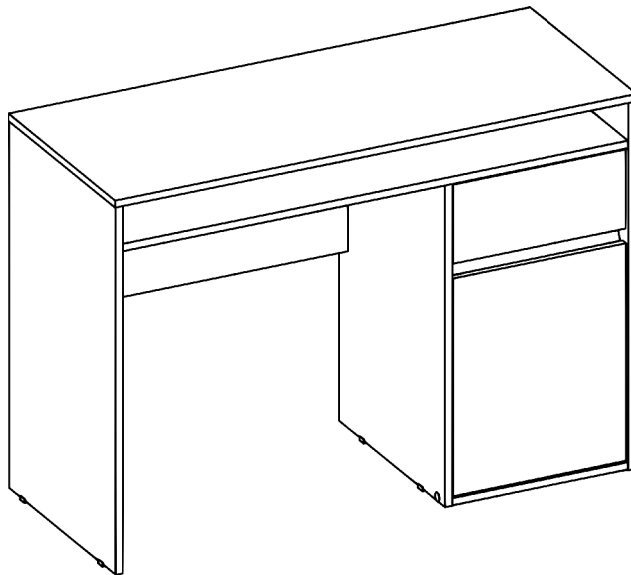

MODEL RTA-957D

ASSEMBLY INSTRUCTIONS

Thank you for purchasing our product.



REV.CMN-6659-0722



P.1	RTA-957D	P.1
-----	----------	-----



- Please read carefully the assembly instructions before the installation.











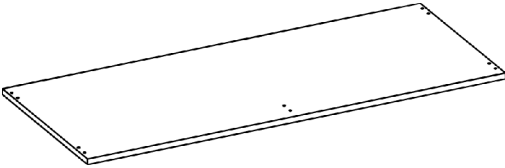

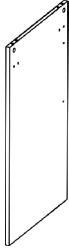
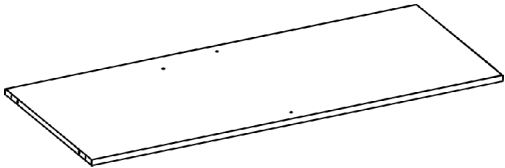
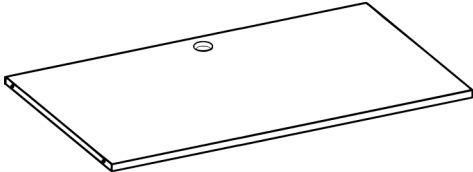
- Do not discard this manual or any of the packaging material until the unit has been completely assembled.

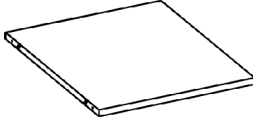
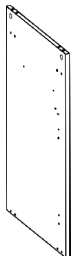

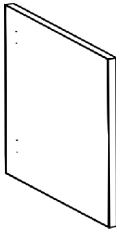
- Might require of two people for the assembly.

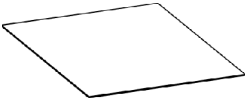





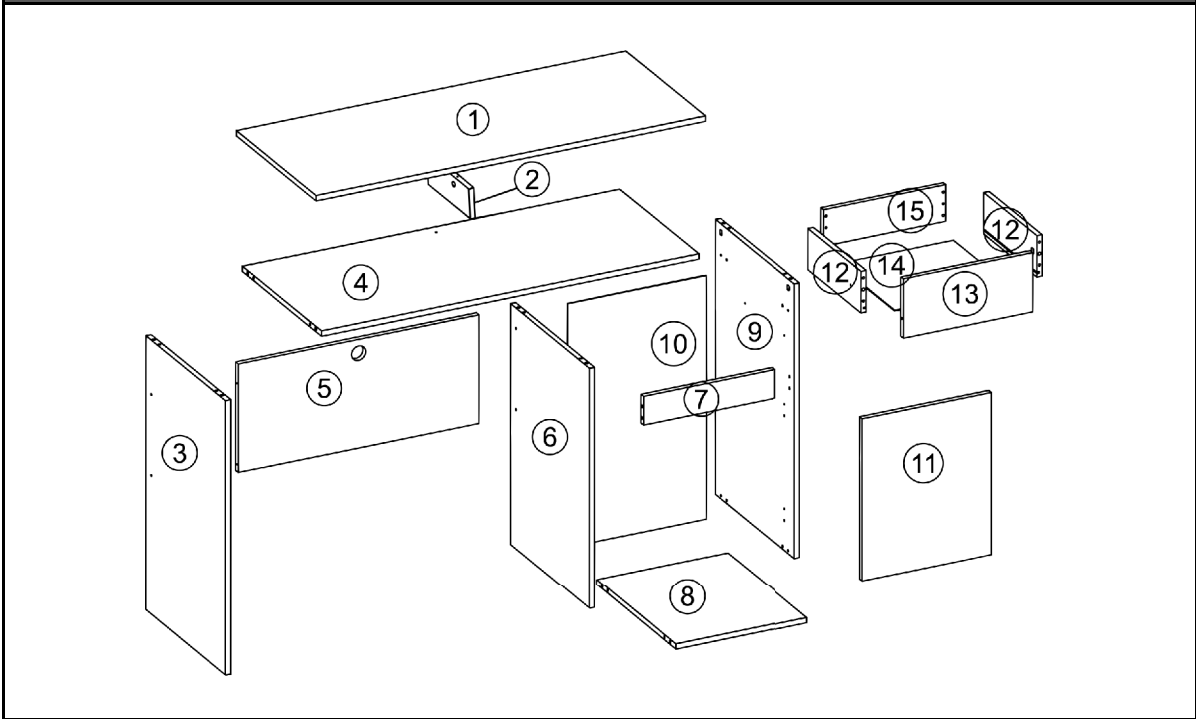

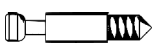

MAIN PARTS LIST

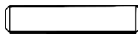
<p>1 Main panel x1</p> 	<p>2 Top support panel x1</p> 	<p>3 Left side panel x1</p> 	
<p>4 Big shelf panel x1</p> 	<p>5 Left back panel x1</p> 		
<p>6 Middle side panel x1</p> 	<p>7 Right support panel x1</p> 	<p>8 Lower panel x1</p> 	<p>9 Right side panel x1</p> 
<p>10 Right back board x1</p> 	<p>11 Door panel x1</p> 	<p>12 Drawer side panel x2</p> 	<p>13 Drawer front panel x1</p> 
<p>14 Drawer bottom board x1</p> 	<p>15 Drawer back panel x1</p> 		



MAIN PARTS LAYOUT (FOR REFERENCE):

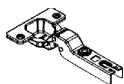

LIST OF INCLUDED HARDWARE

PART	QTY	ITEM		PART	QTY	ITEM	
A	11	Bolt		G	2	Fixed Hinge	
B	15	M4x50		H	25	Wooden dowel M6x30	
C	16	M3.5x12		I	30	Nail 10x10	
D	11	Cam lock		J	1	Grommet (Cable management)	
E	6	Glide (foot)		K	2	Slider	
F	2	Articulated Hinge		L	22	Self-adhesive sticker	

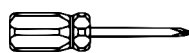
TOOLS THAT ARE REQUIRED (But not included)

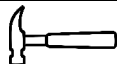
Phillips Screwdriver		Mallet	
Hammer			

☛ This unit uses cam bolts and locks. The following explains how to use them. This is not an assembly step; it is a guide for when you are actually doing the assembly using this kind of hardware.

Cam Lock



Cam Bolt

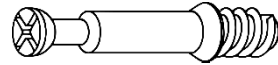

1. Screw the bolt into the corresponding hole on panel "A".

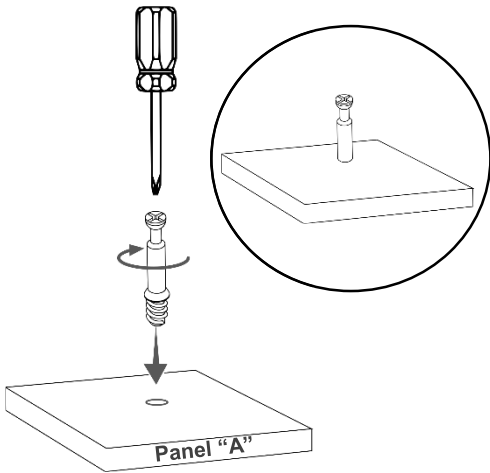

2. Join panel "B" to panel "A". If panel "B" comes with the cam lock pre-installed, make sure it is aligned to receive the bolt's head (refer to point 3). There might be a very small gap between the panels which is normal.

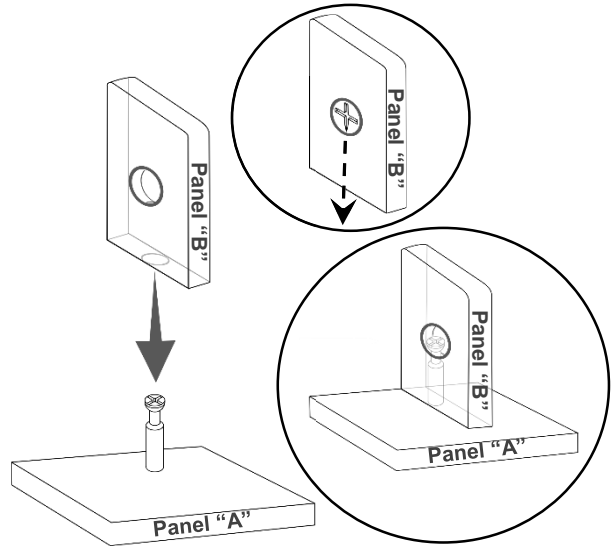

3. Insert the cam lock on panel "B" making sure it goes aligned to receive the bolt's head.

Alignment: The cross points towards the panel "A" with the bolt.

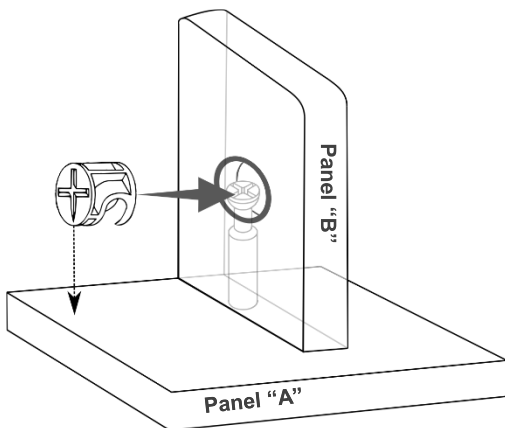

4. Turn the cam lock clockwise. This will lock the parts together and will close any gaps.

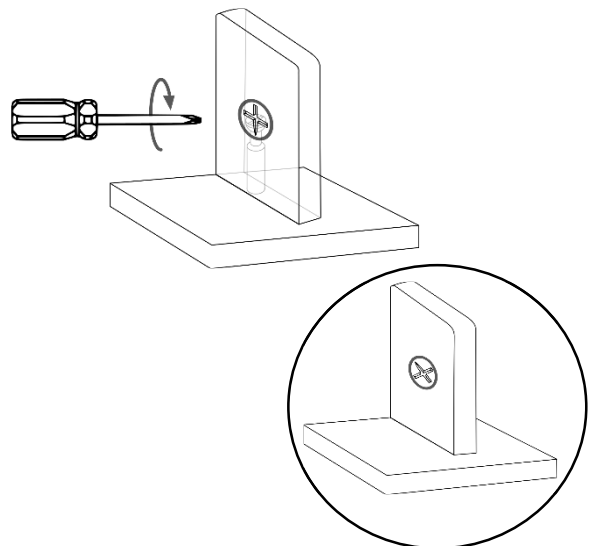

BEFORE YOU START THE ASSEMBLY, PLEASE READ THE FOLLOWING TIPS AND WARNINGS.

1 Do a quick inventory to make sure the package contains all the parts and hardware listed in the assembly instructions.



7 To avoid misalignments, always leave the screws loose and tighten them until all pieces are positioned correctly.

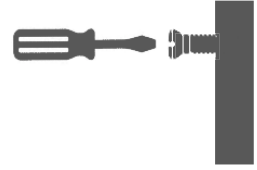

2 Missing, damaged and defective parts can be replaced at no cost to you. Please refer to the last pages on this manual.



8 Do not overtighten or force the screws as they might break, strip, damage the threads of the holes or get stuck inside the part.

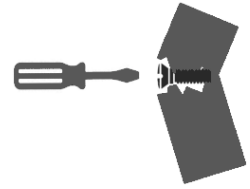

3 The replacement parts service is limited to the 48 contiguous United States. If you reside in Alaska, Hawaii, Puerto Rico, U.S. territories or other countries, please contact the supplier from where the unit was purchased.



9 Sometimes the laminate might cover partially or entirely the hole on a panel. If there is no visible hole for the screw, pass and press the tip of your finger over the area where the hole should be located to feel the indentation, and once found, carefully pierce the laminate to reveal the hole underneath.



4 If during assembly you find an issue or need clarification, please contact our Customer Service for assistance. Please refer to the last pages on this manual.



5 On each step read the instructions and analyze the illustrations thoroughly before proceeding to do the assembly.



10 If the hole seems too small for the screw, first make sure you are using the correct size of screw and that it's been installed in the correct hole. If the hole still appears to be too small, carefully pierce the laminate to reveal the hole's actual size.

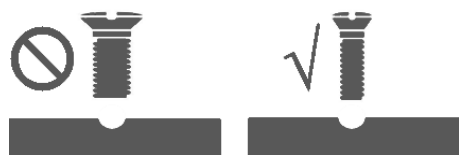

6 Make sure you understand which hardware will be used on each step. Using the wrong size of screw, bolt or pin might strip the threads or cause damage to the part in which it is being used.

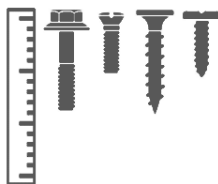

ASSEMBLY STEPS

STEP 1

Hardware:

H



M6x30
Dowel

25
Pcs

Tools required
(But not included)

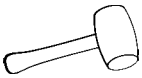

Install the dowels **H** into the indicated holes on panels **2, 3, 4, 6, 7, 8, 9** and **12**.

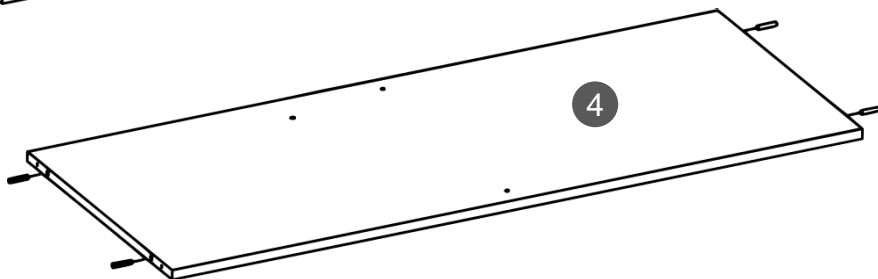
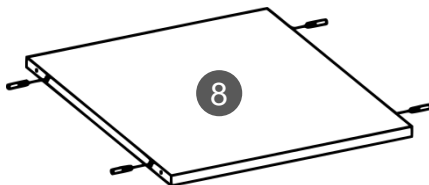
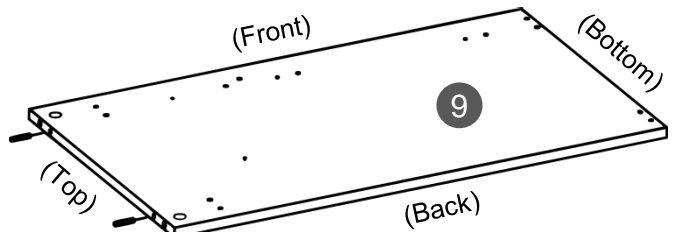
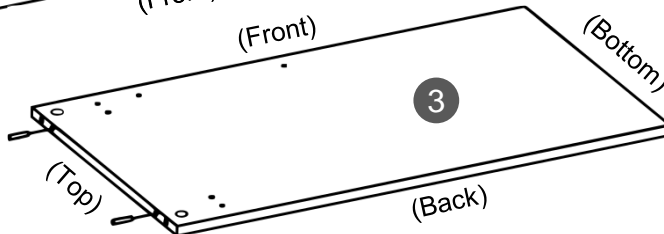
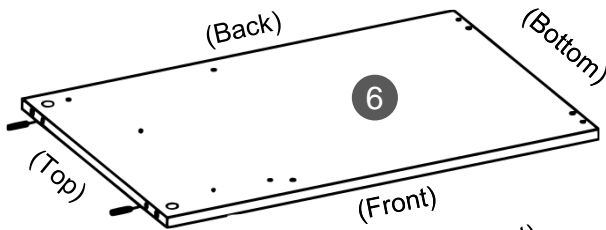
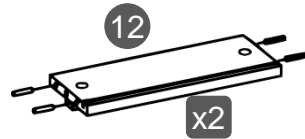
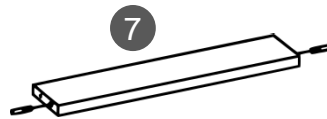
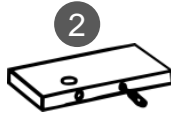

STEP 2

Install the bolts **A** into the indicated holes on panels **1**, **4**, **13**, and **15**.

Hardware:

A		11
	Bolt	Pcs

Tools required
(But not included)

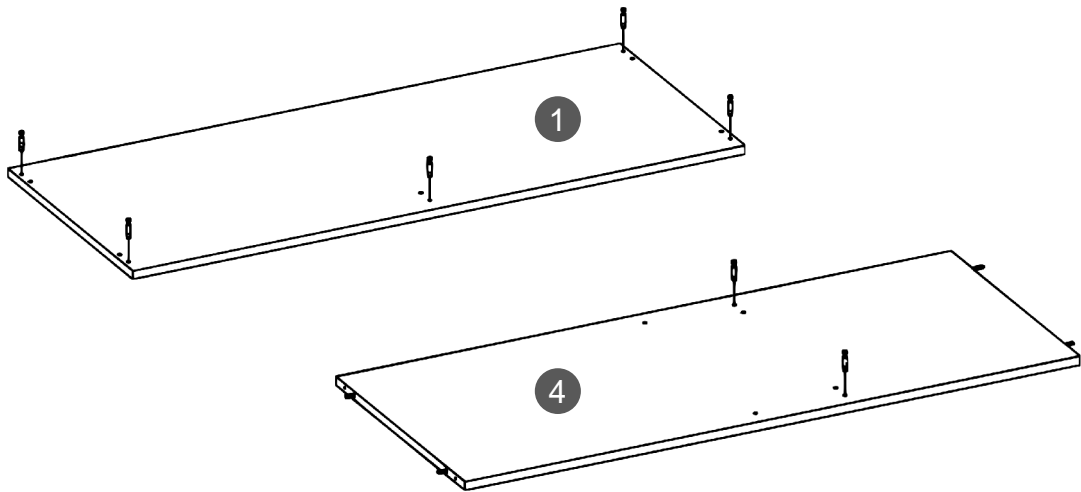
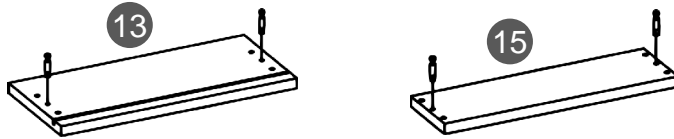
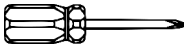

STEP 3

Attach the hinges **F** to the door **11** with screws **C**.

Hardware:

C		4
	M3.5x12	Pcs

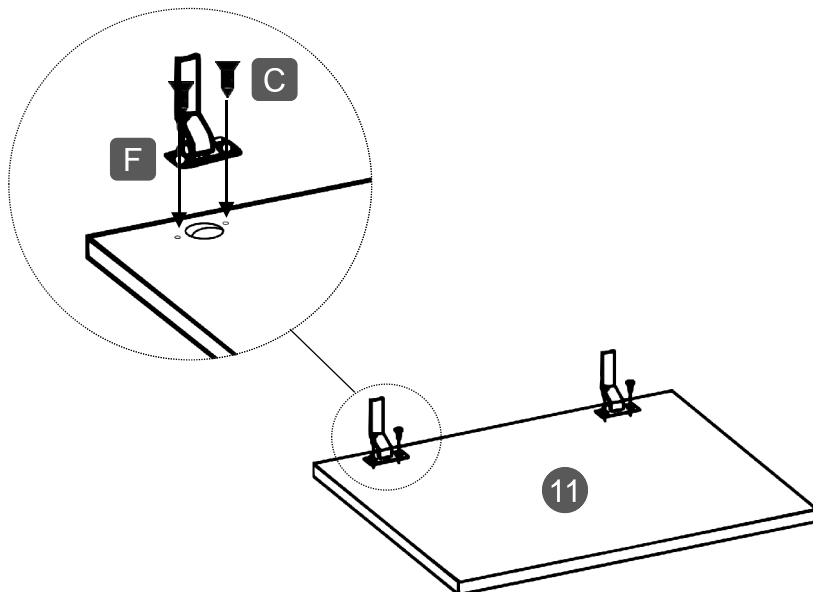
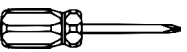

F		2
		Pcs

Tools required
(But not included)



STEP 4

Hardware:

E		6 Pcs
I		6 Pcs

Tools required
(But not included)

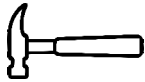

Attach the plastic glides **E** to the bottom of the panels **3**, **6** and **9** with nails **I**.

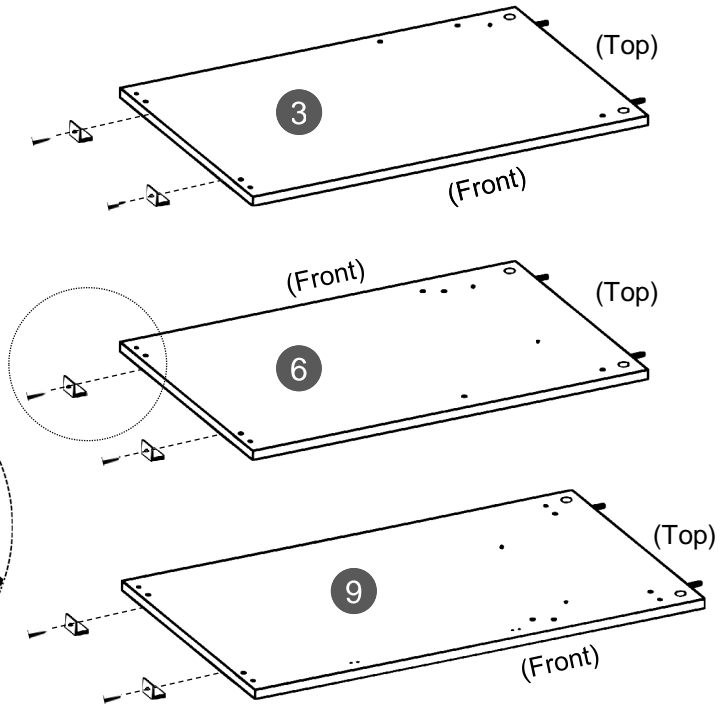
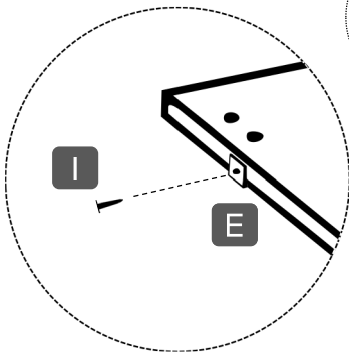

STEP 5

Hardware:

K		2 Pcs
----------	---	-------

- Grab the sliders **K** and extend them completely towards the RIGHT.
- In between the smaller piece and the middle piece there is a black plastic lever sticking out, with the tip of your thumb press the lever UP and at the same time pull out the smaller piece away from the rest.
- The slider will now be split into piece **K-1** (big) and **K-2** (small).

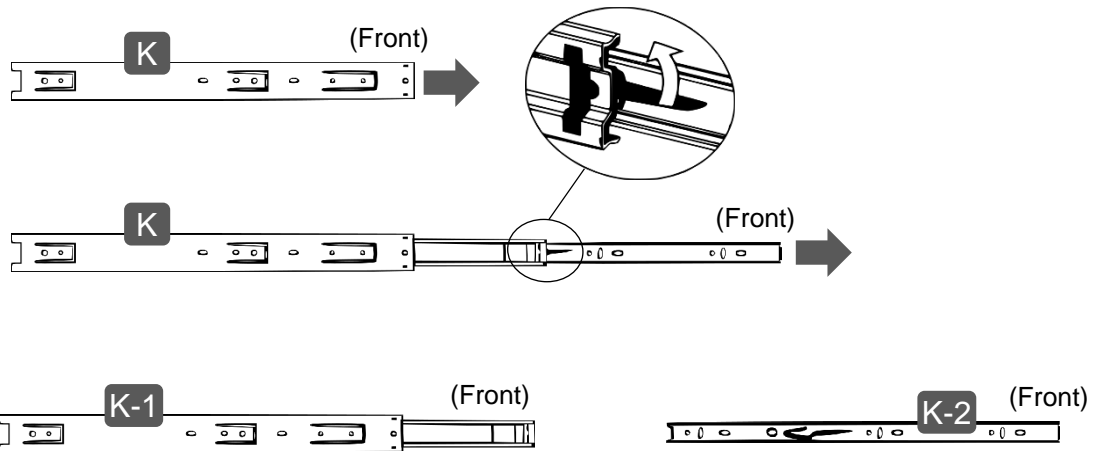



The "Big" pieces K-1 will be used on big panels 6 and 9.

The "Small" pieces K-2 will be used on small panels 12.

STEP 6

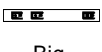
Hardware:

C		8 Pcs
	M3.5x12	
K-1		2 Pcs
	Big	
K-2		2 Pcs
	Small	

Tools required
(But not included)

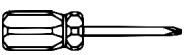

Important notes for this step:

- Both panels **12** are exactly the same, however, one will be used as **RIGHT** side and the other as **LEFT** side.
 - All the pieces of sliders **K-1** and **K-2** have a front end that will need to face towards the front of the panels.
- Flip the panels **12** and assemble to them the small sliders **K-2** with screws **C**, but oriented opposite on each panel. Make sure that the grooves on the other side are located at the **BOTTOM**.

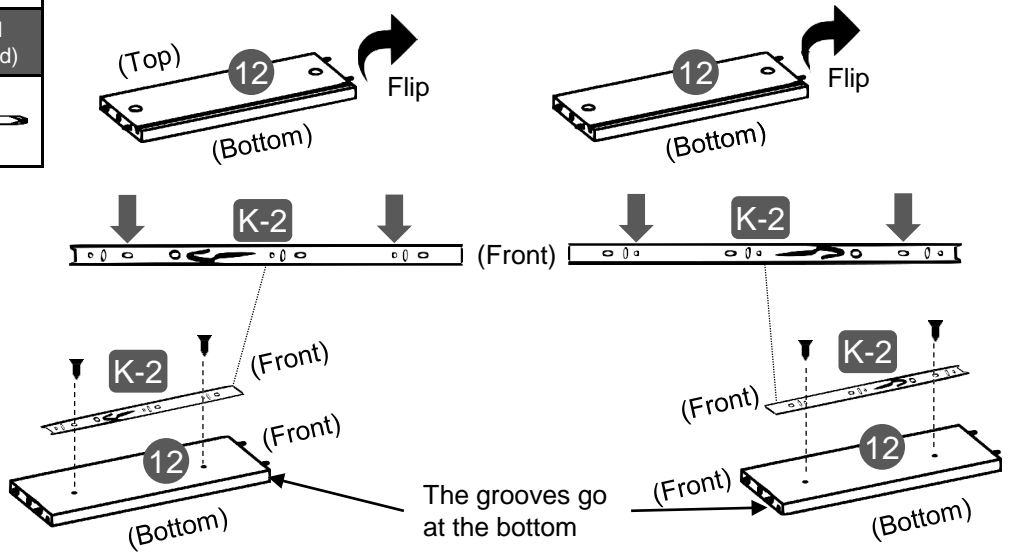

- Assemble the big sliders **K-1** to the panels **6** and **9** on the top sets of holes with screws **C**. Attach first the back hole (2nd from the back end), then open the slider slowly until you are able to see the front hole (1st from the front end). You might need to slide away the piece with the ball bearings to clear the view of the hole.

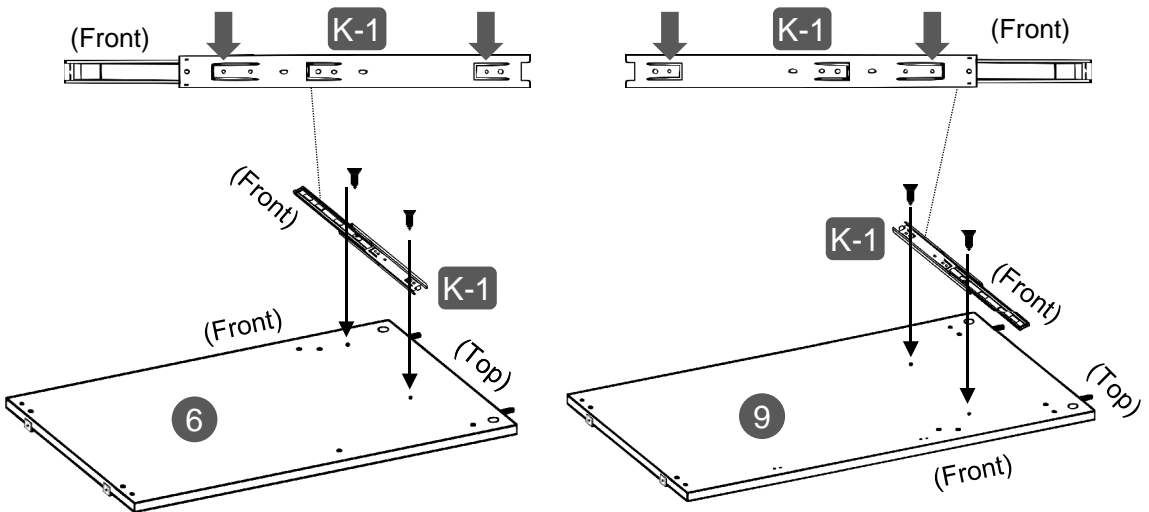

STEP 7

Requires of 2 persons 

Hardware:

D  3 Pcs
Cam lock

Tools required
(But not included)

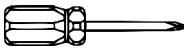

With the help of another person:

- Join the top support panel **2** and the left side panel **3** to the main panel **1**.
- Insert the cam locks **D** on panels **2** and **3** and turn them to lock the pieces as shown and as explained in page 4.

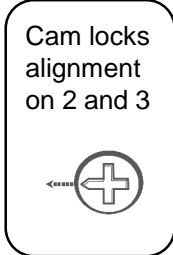
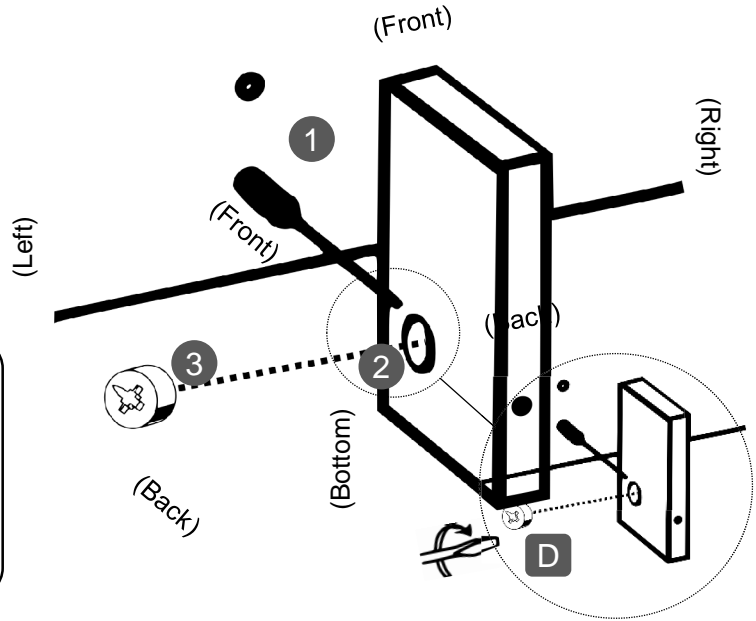

STEP 8

Requires of 2 persons 

Hardware:

B  3 Pcs
M4x50

Tools required
(But not included)



With the help of another person, assemble the big shelf panel **4** to panels **2** and **3** with screws **B** as shown.

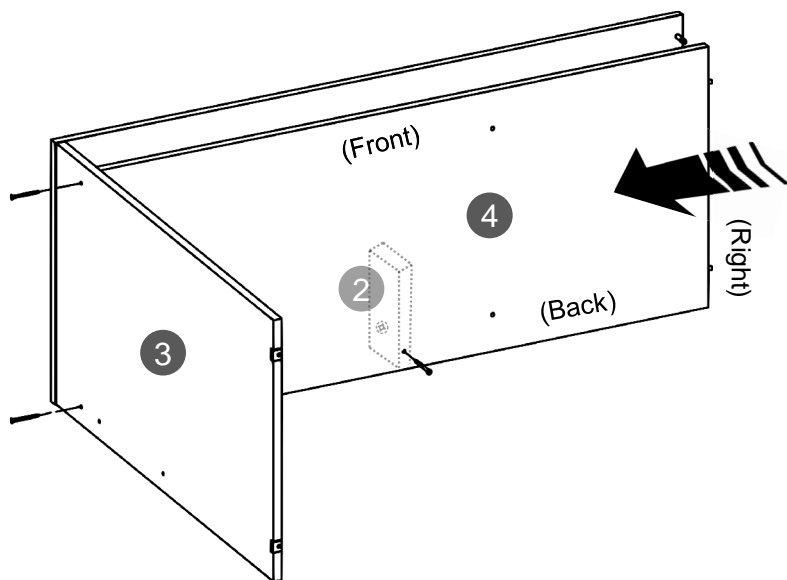

STEP 9

Hardware:

B		2
	M4x50	Pcs

J		1
		Pc

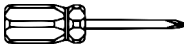
Tools required
(But not included)

- Attach the grommet **J** to the left back panel **5**.
- Assemble panel **5** to the left side panel **3** with screws **B** as shown.

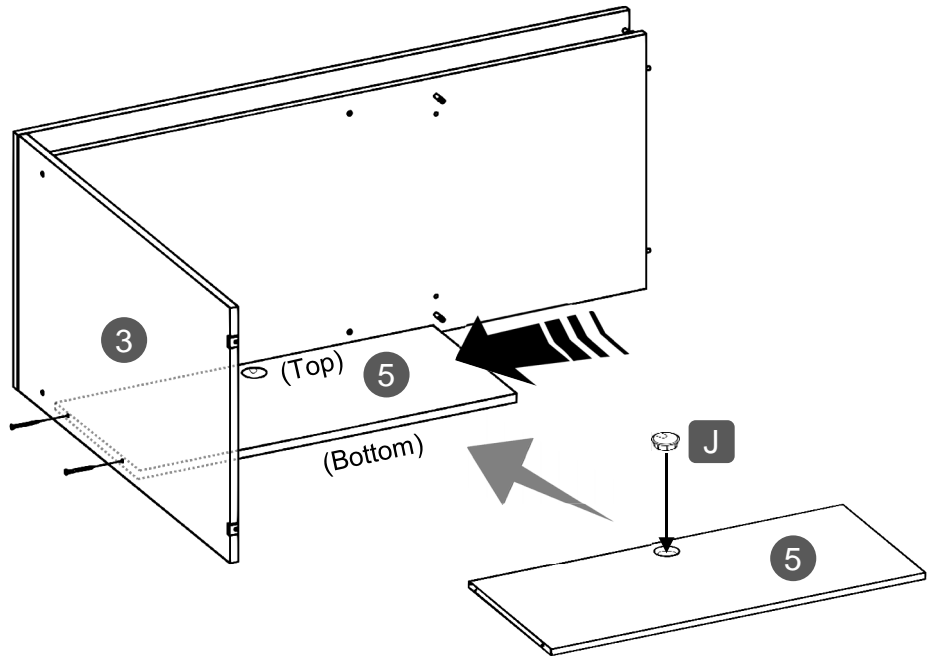

STEP 10

Hardware:

D		2
	Cam lock	Pcs

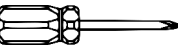
Tools required
(But not included)

- Assemble the middle side panel **6** to the big shelf panel **4** with cam locks **D** as shown and as explained in page 4.

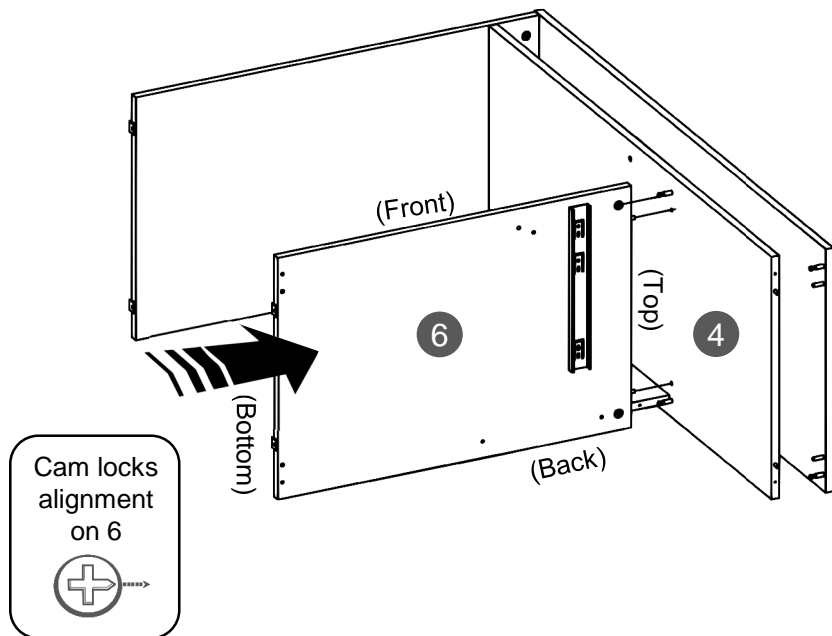

STEP 11

Hardware:

B

M4x50

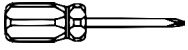
2
PcsTools required
(But not included)

Secure the middle side panel **6** to the left back panel **5** with screws **B**.

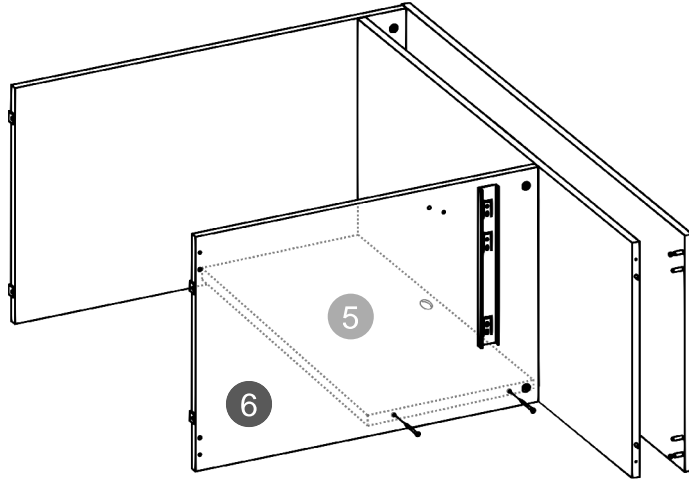

STEP 12

Hardware:

B

M4x50

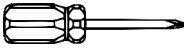
3
PcsTools required
(But not included)

Assemble the support panel **7** and the lower panel **8** to the middle side panel **6** with screws **B** as shown. Note that the support panel **7** goes slanted.

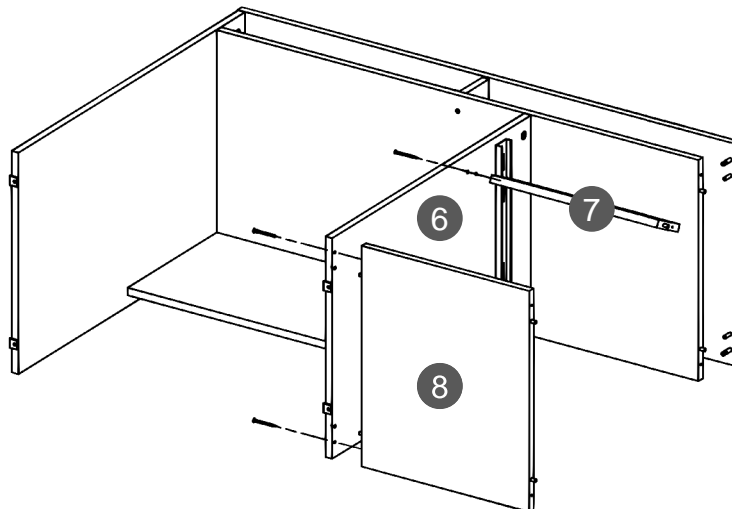

STEP 13**Hardware:**

Tools required
(But not included)

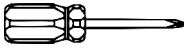

Assemble the right side panel **9** to the main panel **1** with cam locks **D** as shown and as explained in page 4.

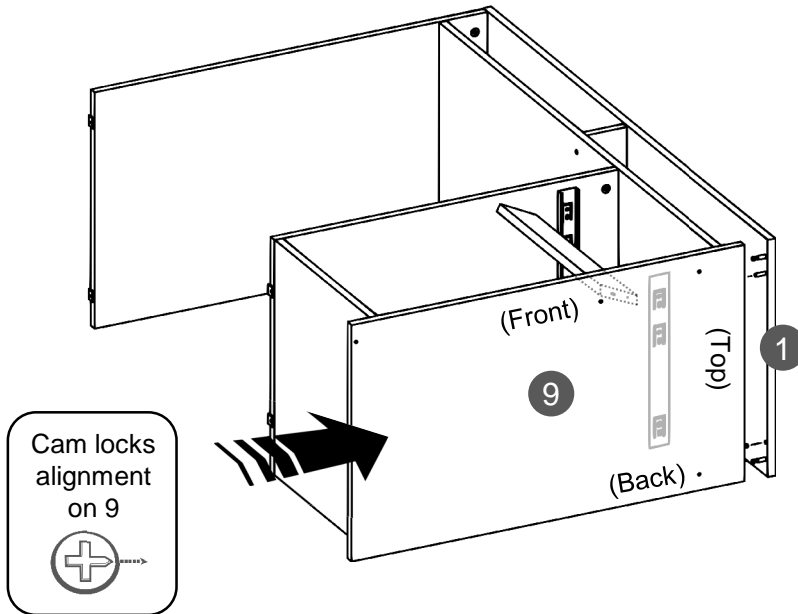
**STEP 14****Hardware:**

Tools required
(But not included)

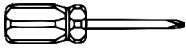

Secure the panel **9** to panels **4**, **7** and **8** with screws **B** as shown.

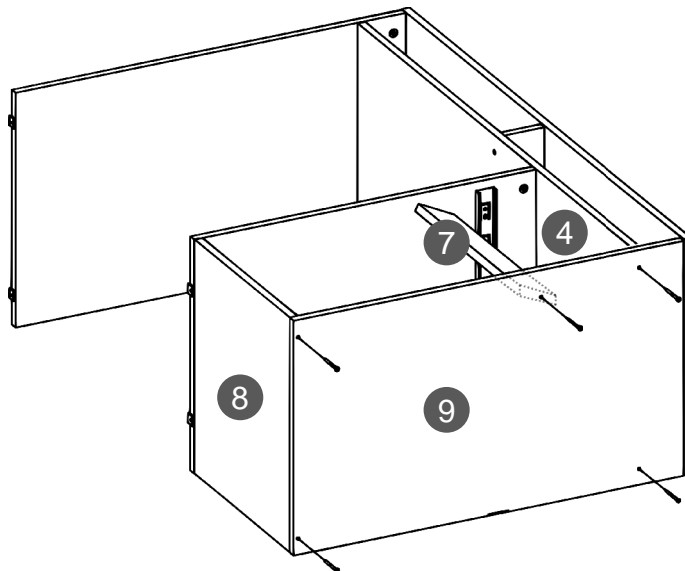

STEP 15

Requires
of 2
persons

Hardware:

I



Nail

Min
16
PcsTools required
(But not included)

- With the help of another person, bring the unit upright.
- One person places and holds the right back panel **10** centered over the back of the cabinet, while the other person secures it with a minimum of 16 nails **I** as shown (leave at least 2 nails available for step **20**).
- It is recommended to put first one nail at the center on the top and other at the bottom, then the rest.

IMPORTANT: Try to nail into the center of the board edges and as straight as possible to avoid the nails entering too close to the edges or slanted as the wood might bulge or split.

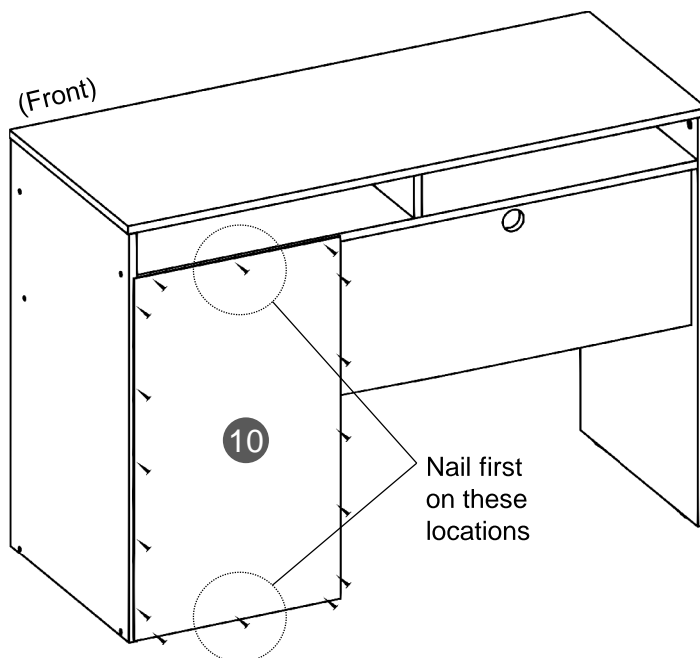
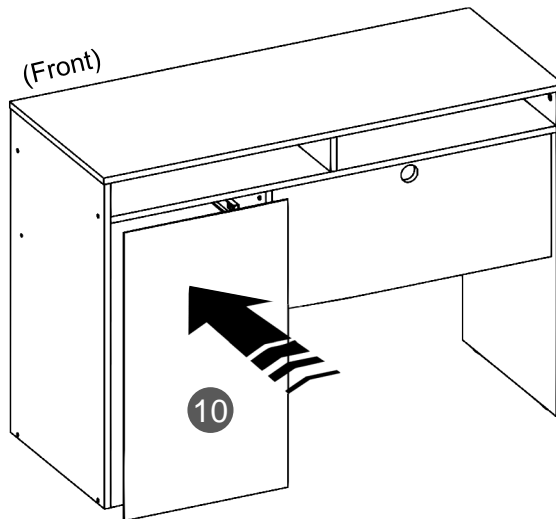

STEP 16

Requires of 2 persons 

Hardware:

C  M3.5x12 4 Pcs

G  2 Pcs

Tools required (But not included)

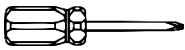

- Slide the hinge **G** under the hinge **F** (from the door **11**) to join both pieces, and secure them with the screw from **G**.
- With the help of another person, attach the hinges to panel **9** with screws **C**.

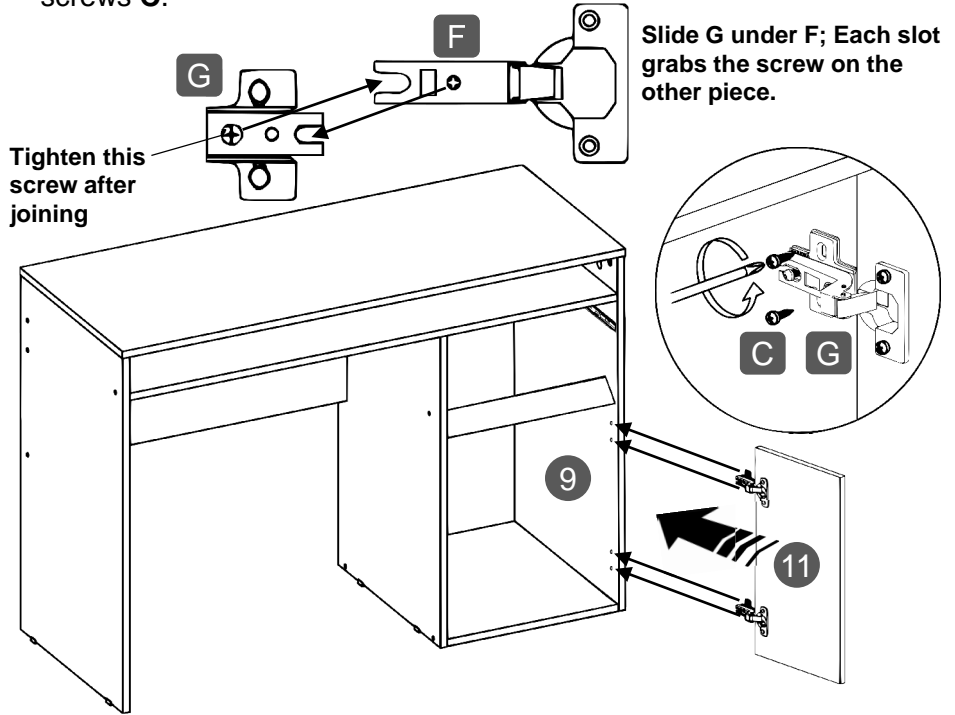

HINGES ADJUSTMENTS FOR DOOR ALIGNMENT

STEP 17

Requires of 2 persons 

Tools required (But not included)

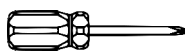

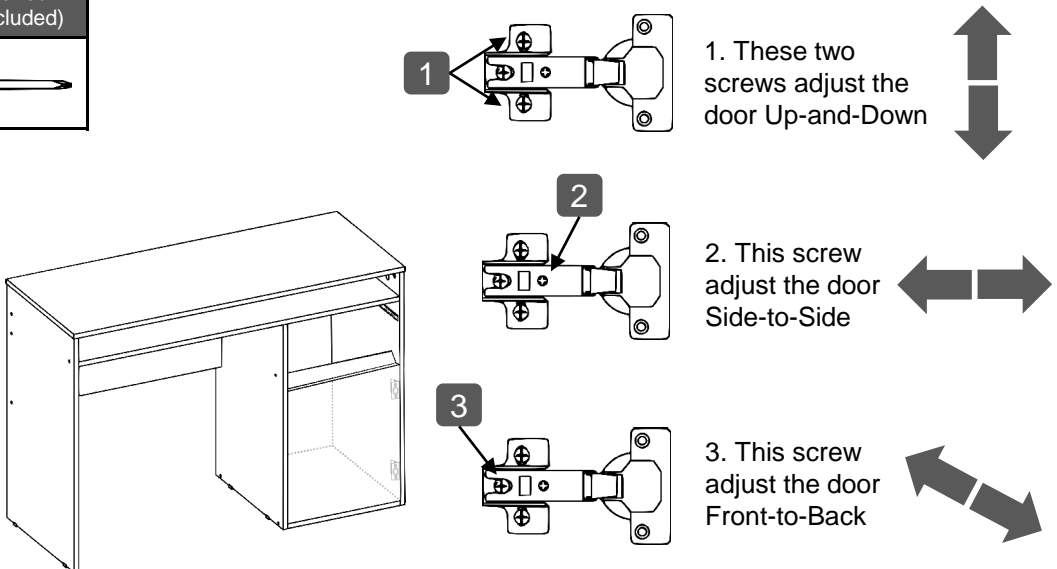

- If the door does not close properly or is misaligned, follow the instruction below, otherwise, you can skip and continue with step **18**.
- With the help of another person, loosen up the indicated screw(s) on the hinges, adjust the door position, and re-tighten the screw(s).



STEP 18

Hardware:

D		2 Pcs
L		2 Pcs

Tools required
(But not included)

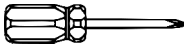

Important notes for this step:

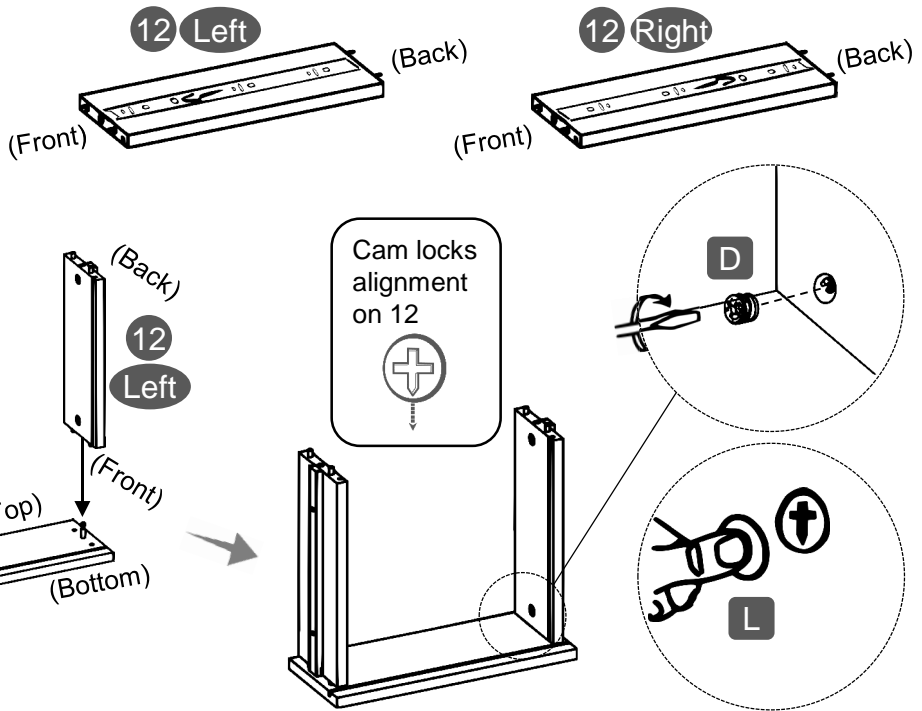

For the drawer, you will use both panels **12**, but one will go as the **RIGHT** side and the other as the **LEFT** side, so make sure that the sliders **K-2** on them are facing the opposite direction as it was instructed in **Step 6** on page **9**.

- Assemble the panels **12** to the drawer front panel **13** on their respective sides with cam locks **D** as shown and as explained in page **4**.
- Cover the cam locks with **L**.



STEP 19

Hardware:

D		2 Pcs
L		2 Pcs

Tools required
(But not included)



Assemble the drawer back panel **15** to the side panels **12** with cam locks **D** as shown and as explained in page **4**, then cover the cam locks with **L**.

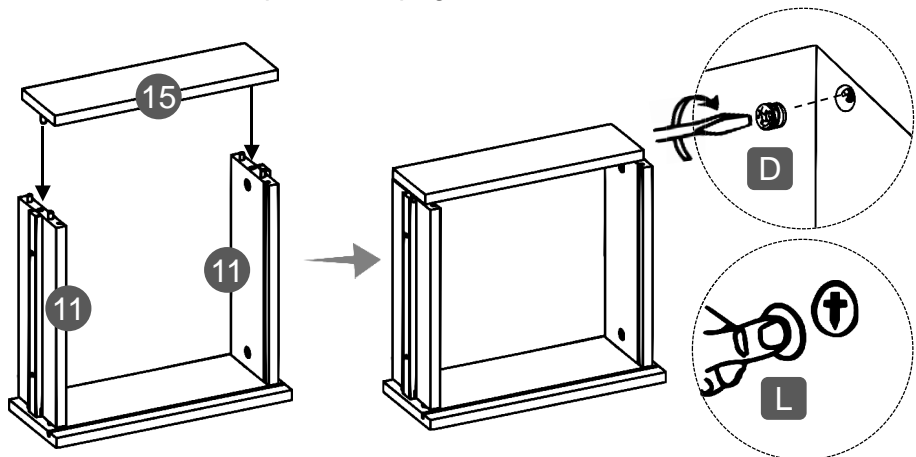

STEP 20

Hardware:

L		Min
	Nail	2 Pcs

Tools required
(But not included)

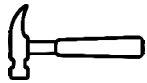

- Slide the drawer bottom board **4** through the grooves of panels **12** and into the groove of panel **13**.
 - Secure the bottom board **14** at the back with at least 2 nails **L**.
- IMPORTANT:** Try to nail into the center of the boards and as straight as possible to avoid the nails entering too close to the edges or slanted as the wood might bulge or split.

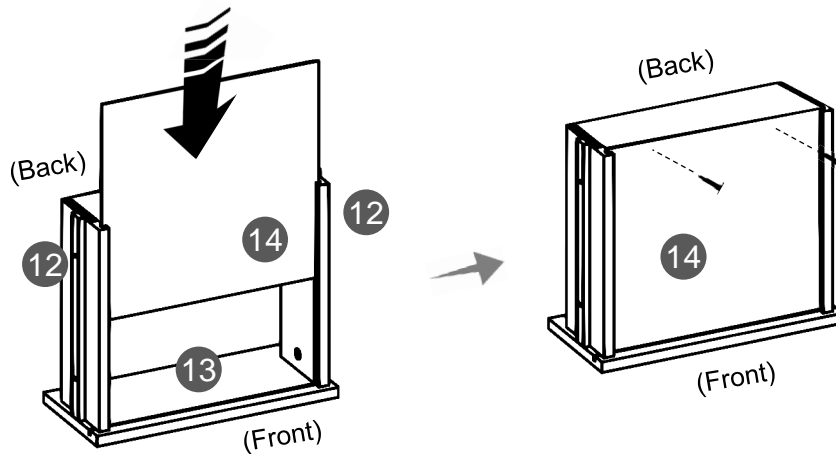

STEP 21

Hardware:

L		18
	Sticker	Pcs

- On the main unit first make sure that on the sliders **K-1** the piece with the ball bearing is all the way to the front. If they are not, slide them with the tip of your finger towards the front.
- Install the drawer by engaging its sliders **K-2** through the black plastic guide and the bearings of **K-1**, and pushing slowly inside.
- Cover all visible screw holes and cam locks on the unit with **L**.

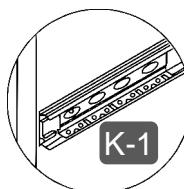
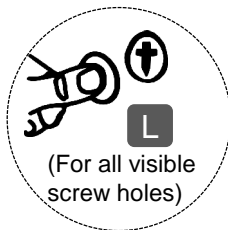
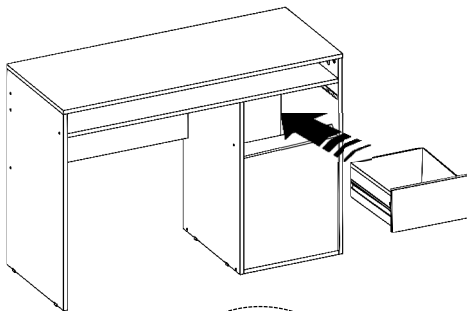

1. Make sure the piece with the ball bearings is all the way to the front.

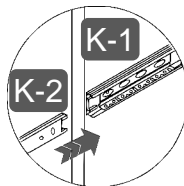

2. The slider K-2 must go through the plastic guide and engage into the ball bearing piece of K-1.

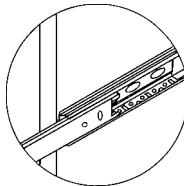

3. Push in very slowly.



ALL DONE!

Give yourself a nice pat on the back, you did a great job!

Enjoy your new unit.

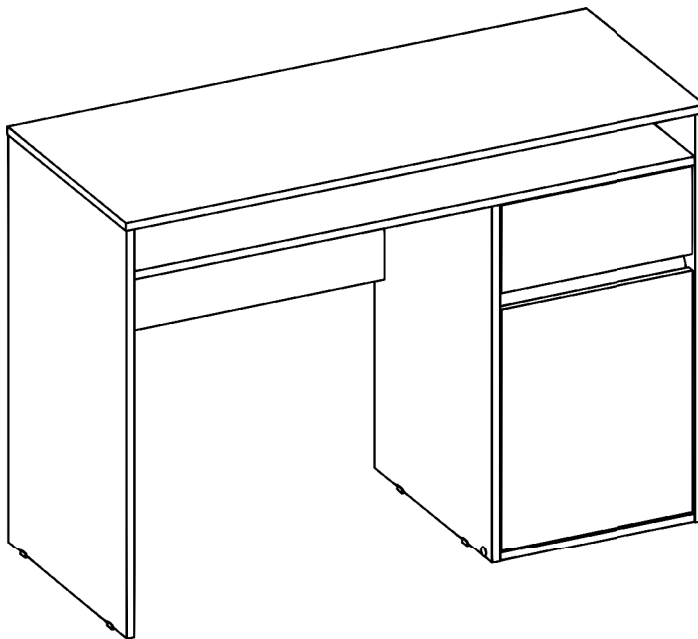

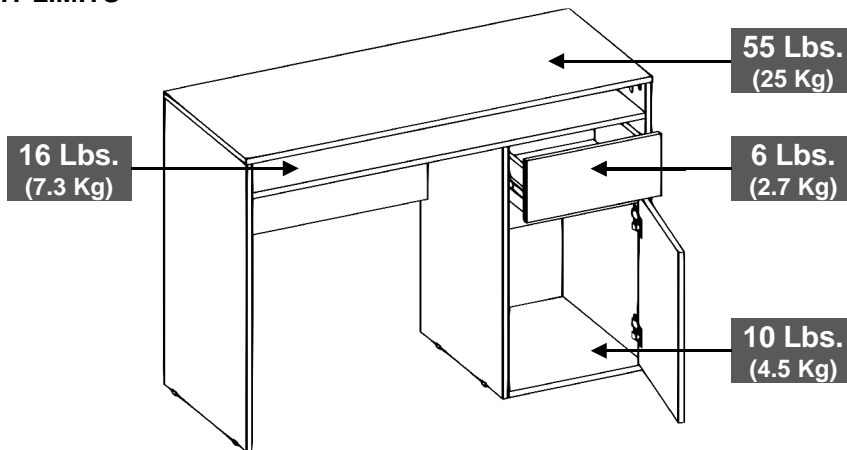
CARE, MAINTENANCE AND SAFETY WARNINGS:**WEIGHT LIMITS**

- Do not exceed the indicated weight limits.
- Do not expose the surfaces to direct sunlight or to extreme environmental conditions.
- Clean the surfaces preferable with a clean cloth damped in a solution of mild soap and water, then dry with a clean towel.
- Do not use solvents or abrasive materials to clean the unit.
- If you decide to use a cleaning agent, test first on an area hidden from view such as underneath the tabletop.
- Do not sit on the unit or lean against it.
- Do not allow small children to play under, over or inside the unit.
- Do not allow small children to reach inside the drawers or compartments without your supervision.
- Do not pull, push or drag the unit to move it for more than 1 feet. The unit must be lifted by at least 2 persons when moving in the same or adjacent rooms.
- Before moving the unit, make sure to secure or remove any object that is heavy or might fall off.
- When lifting the unit, use both hands and bend your knees, not your backs.
- When transporting the unit to places far away, protect and secure the unit to avoid damage in transit.
- Shall any part of the unit become defective during the warranty period, replacement parts might be available to you at no charge. Please refer to the last pages on this manual.
- The warranty does not extend to regular wear and tear, nor the manufacturer assumes liability for damages or consequences due to accidents, incorrect assembly, negligence, improper use, modifications, or not heeding the above warnings.

TECHNI MOBILI DESK WARRANTY

DESKS/LAPTOP CARTS/FILE CABINETS: LIMITED 5-YEAR WARRANTY

RTA Products, LLC warrants to the Original Purchaser who acquired a new product from RTA Products or its authorized resellers that this product will be free from defects in its workmanship and materials, under normal use and service conditions, as described herein. "Defects" as used in this warranty, is defined as any imperfections that impair the use of the furniture or product. RTA Products LLC will replace any defective part, at its discretion, and without charge to the original purchaser other than the freight from the end consumer to RTA Products.

Replacement parts can only be supplied if parts are available. Items out of production may be unavailable. This warranty will be effective for the applicable time period beginning the date of purchase on your original sales receipt. RTA product's obligation under this warranty is limited to repairing or replacing products or parts as provided herein. This product has been designed for and is intended for office and home-office use only. This warranty is Original Purchaser's sole remedy for product defects, and this warranty does not extend to any product, or damage to any product, caused by or attributed to abuse or misuse, products used for commercial or rental purposes, use modifications of, or attachments to the product, and products or parts not used, maintained, or extended hereunder is in lieu of any and all other warranties, express or implied, including without limitations any implied warranty or merchantability or of fitness for a particular purpose. Please note, all desks made with PVC Laminate surface should not be exposed to direct sunlight, as it may damage the material. Damage of this nature is not covered under this warranty.

RTA Products will not be responsible for indirect, special, incidental or consequential damages. This warranty is limited to merchandise purchased in the Continental United States, excludes AK, HI and PR. Some States do not allow the exclusion or limitation of incidental or consequential damages, so the above limitations or exclusions may not apply to you. This warranty gives you specific legal rights. You may also have other rights that may vary from state to state.

RTA Products will advise you of the procedure to follow in making warranty claims. The following are the procedures for warranty claims:

- a. Call us Monday – Friday, from 9am-5pm (Eastern Time) at (866) 782-5520 to explain the defect and give your name, address and phone number. Please have ready the model number of our product, date and place of purchase. You can also write to us by e-mail to warranty@rtaproducts.com and include the same information.
- b. If we determine that replacement will remedy the situation, and in order to determine the extent or the cause of the defect, purchaser will need to send the part in question at purchaser's expense. Once we receive the part, we will examine it and determine whether the claim is valid (or not), and then proceed to send the replacement. We will ship the replacement at our expense.

FOR SEVERAL HELP OPTIONS INCLUDING REPLACEMENT PARTS ORDERS

VISIT: WWW.TECHNIMOBILI.COM



CLICK ON SUPPORT TAB



Scan QR Code to order replacement parts

OR EMAIL US: SUPPORT@RTAPRODUCTS.COM