

**MODERN TV STAND WITH STORAGE**

**MODEL RTA-8850**

**ASSEMBLY INSTRUCTIONS**

REV-6-FP-7812-1223

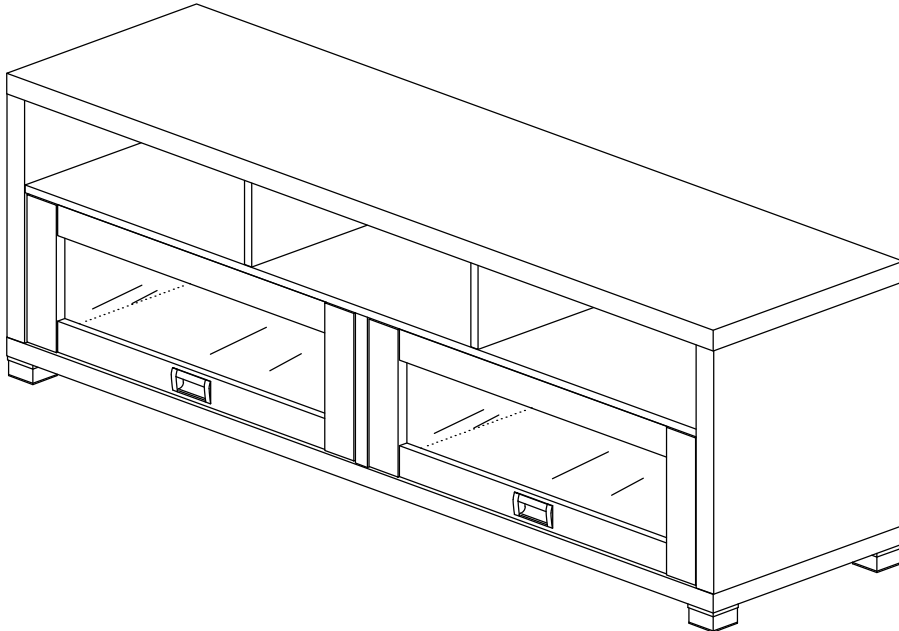

**Thank you for purchasing our product**

**VIDEO**



**Scan QR to view full  
assembly video**

<p>Do a quick inventory of all the parts and hardware listed below.</p> 	<p><b>For Support, assembly questions &amp; Replacement Parts within the 48 Contiguous United States:</b></p> <p>Please email us at: <a href="mailto:support@rtaproducts.com">support@rtaproducts.com</a></p> 	<p>Replacement Parts for International Customers &amp; <b>AK-HI-PR</b> orders: RTA Products will replace the part free of charge, while <b>the customer is responsible for shipping costs plus any International local taxes or duties.</b></p>
---	---	---



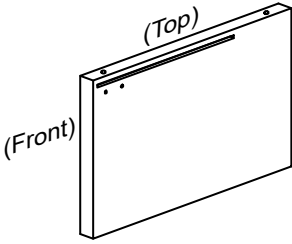
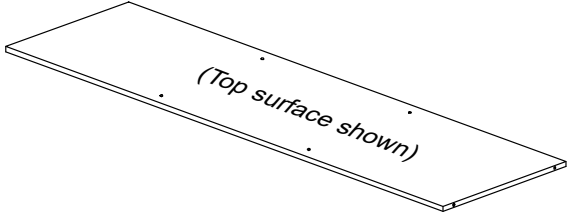
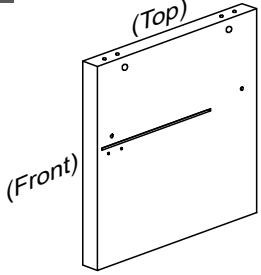
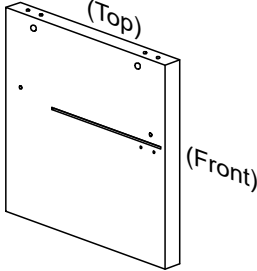
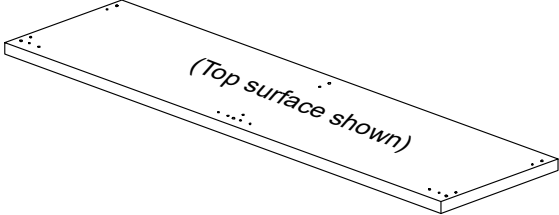
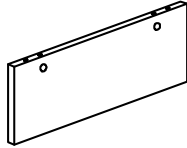
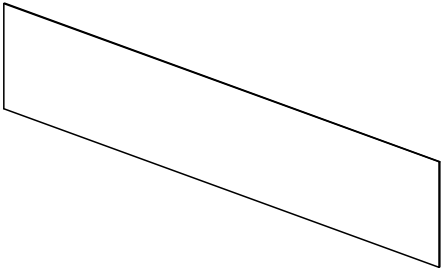
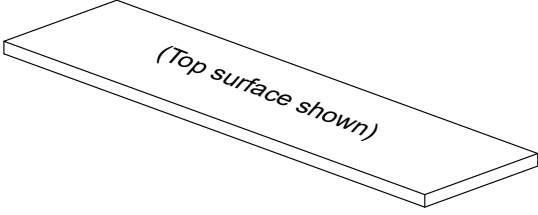
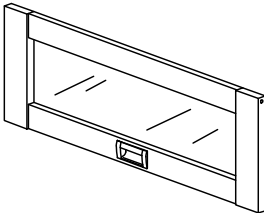
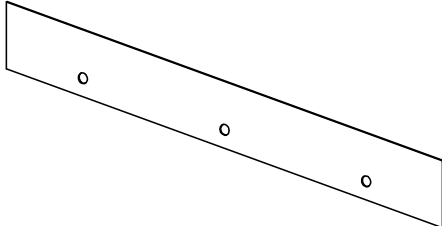



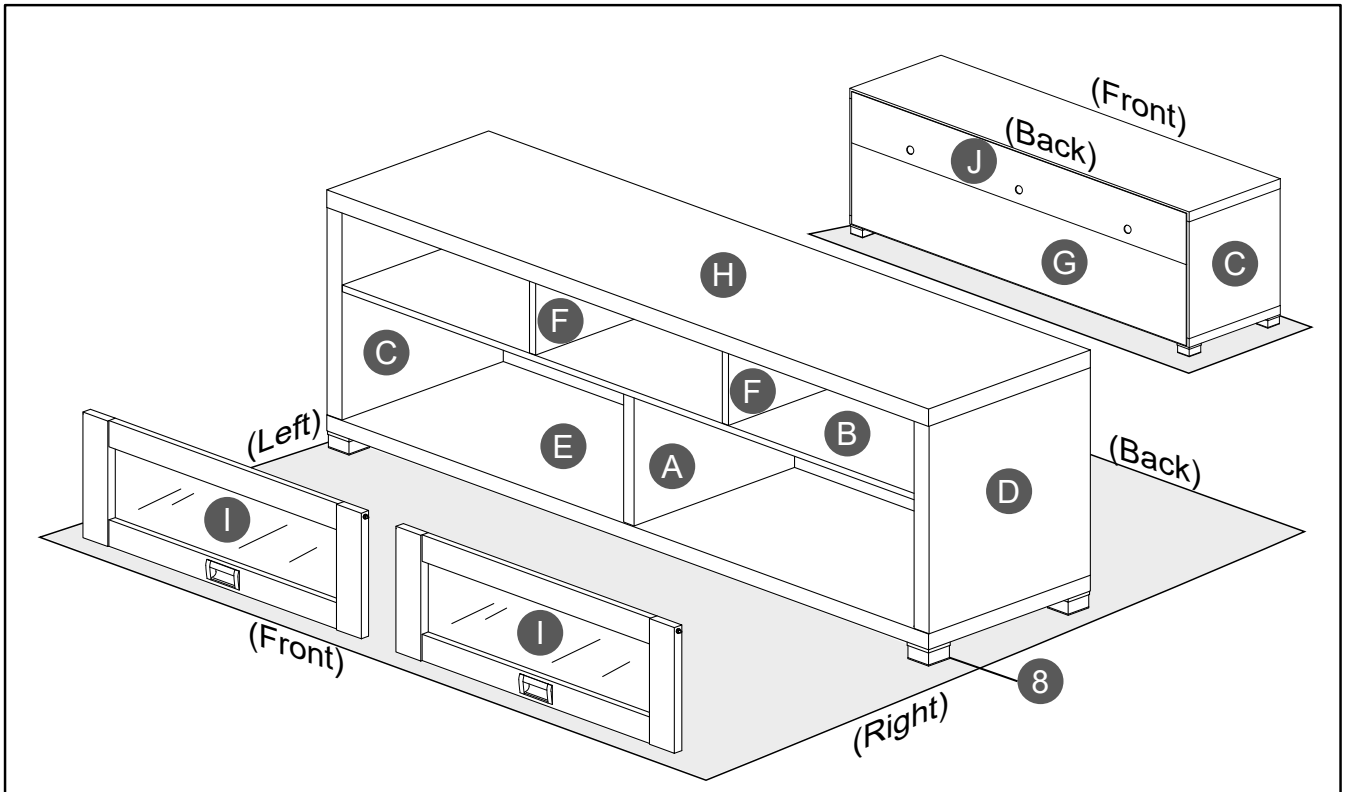

## MAIN PARTS LIST

<p><b>A</b> x1</p> <p>Bottom divider panel</p> 	<p><b>B</b> x1</p> <p>Middle shelf panel</p> 	<p><b>C</b> x1</p> <p>Left side panel</p> 	
<p><b>D</b> x1</p> <p>Right side panel</p> 	<p><b>E</b> x1</p> <p>Bottom panel</p> 	<p><b>F</b> x2</p> <p>Top divider panel</p> 	
<p><b>G</b> x1</p> <p>Bottom back panel</p> 	<p><b>H</b> x1</p> <p>Top panel</p> 		
<p><b>I</b> x2</p> <p>Glass door</p> 	<p><b>J</b> x1</p> <p>Description</p> 		



**MAIN PARTS LAYOUT (For reference)**



**HARDWARE LIST AND INCLUDED TOOLS**

PART	QTY	SIZE / DESCRIPTION	ITEM
1	24	Ø6x25 Wooden Dowel	 0 10 20 30 40 50 60
2	8 Sets	M6x32 Cam lock and bolt	 0 10 20 30 40 50 60
3	20	M3.5x16	 0 10 20 30 40 50 60
4	6	M4X65	 0 10 20 30 40 50 60
5	50	20mm Nail	 0 10 20 30 40 50 60
6	4	M6x22 Double metal pin	 0 10 20 30 40 50 60
7	4	Plastic door stopper	
8	5	50x50x40mm Plastic foot	
9	4 Sets	Magnet and screw	

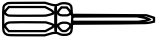
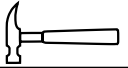
**TOOLS REQUIRED BUT NOT INCLUDED**

1	Phillips Screwdriver	
1	Hammer	
1	Mallet	

If you will use a power driver:

- Make sure to have the appropriate Phillips bits.
- Start using at a low torque or speed to avoid stripping the screws.

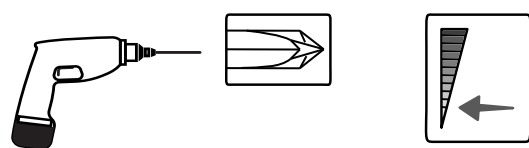

**BEFORE YOU START THE ASSEMBLY, PLEASE READ THE FOLLOWING TIPS AND WARNINGS.**

- Do not discard this manual or any of the packaging material until the unit is completely assembled.
- Please read the assembly instructions thoroughly and follow step by step.



- The assembly might require of 2 persons for certain steps. Before you start the installation, make sure there is someone else nearby to help you.

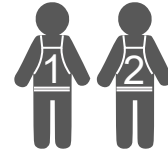

- Make sure you understand which hardware will be used on each step. Using the wrong size of screw, bolt or pin might strip the threads or cause damage to the part in which it is being used.

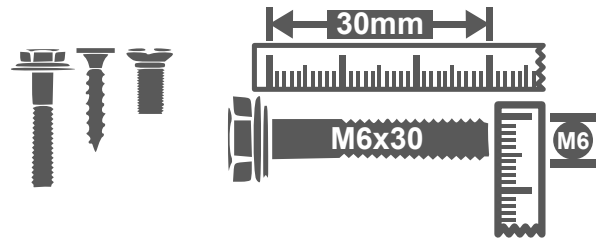

- To avoid misalignments, always leave the screws loosely and do not tighten them until all the pieces are positioned correctly.
- Do not overtighten or force the screws as they might break, strip, damage the threads of the holes, or get stuck inside the parts.



- If the hole seems to small for the screw, make sure you are using the correct size of screw and/or that you are installing it in the correct hole.



- Sometimes on the wood panels the laminate or material might be covering the hole partially or entirely, if there is no visible hole or if it looks too small, pass and press the tip of your finger over the area to feel its indentation, and carefully pierce the laminate to uncover the hole underneath.

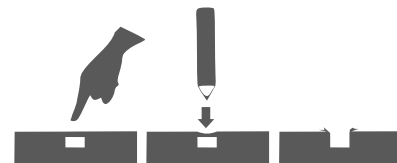

- Please be kind to our planet, when done with the assembly, recycle any of the packaging materials that is accepted by your city or recycling service.



Thank you!



**ASSEMBLY STEPS**

**WE RECOMMEND TO PLACE THE PIECES OVER BLANKETS OR TABLECLOTHS TO PROTECT THEIR FINISH DURING ASSEMBLY.**

**STEP 1**

Insert the wooden pins ( 1 ) into panels ( A - B - C - D - F ) as shown.

**Hardware:**

1  x24



Scan QR Code to view this step

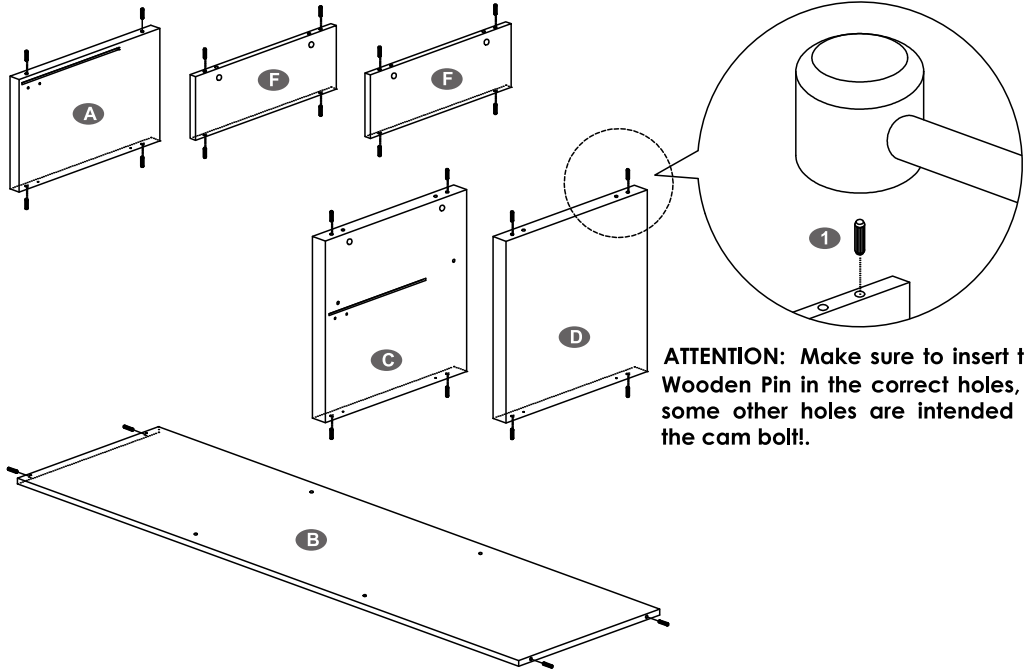

**ATTENTION:** Make sure to insert the Wooden Pin in the correct holes, as some other holes are intended for the cam bolt!.

**⚠ ATTENTION: DO NOT JOIN ANY PARTS IN THIS STEP!**

**STEP 2**

Attach Door Stopper ( 7 ) to the **RIGHT** side of panel ( A ) and panel ( C ) as shown.

**Hardware:**

7  x2



Scan QR Code to view this step

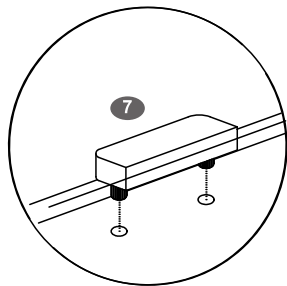

FRONT

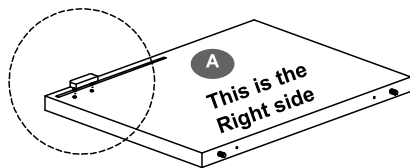

FRONT

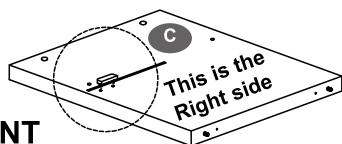

**STEP 3**

Attach Door Stopper ( 7 ) to "left side" of panel ( A ) and panel ( D ) as shown.

**Hardware:**

7  x2



Scan QR Code to view this step

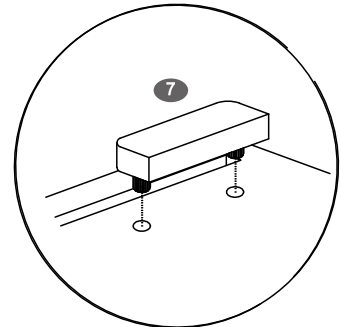

FRONT

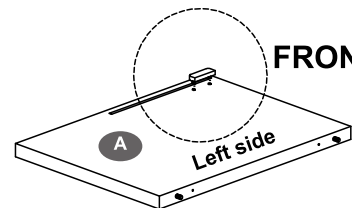

FRONT

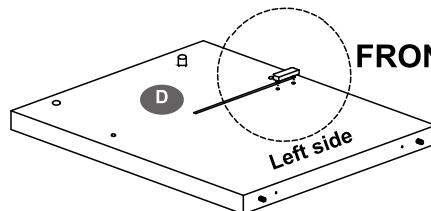

**STEP 4**

Remove the top caps from the Plastic Feet ( 8 ) and assemble the to bottom panel ( E ) using screws ( 3 ) as shown.

**Hardware:**3  x208  x5

Scan QR Code to  
view this step

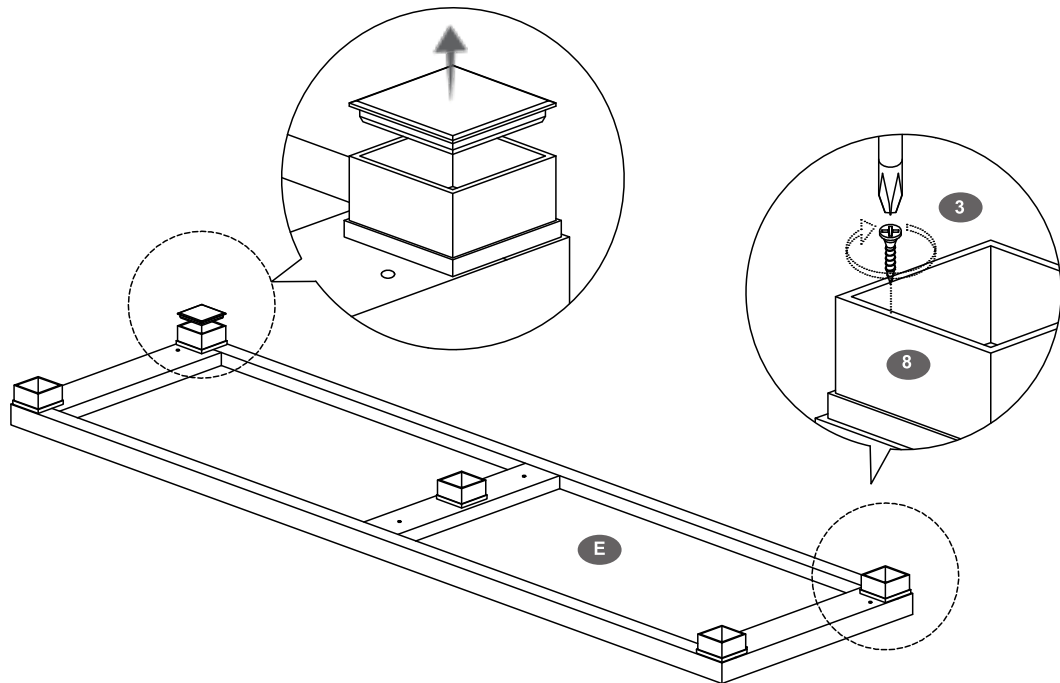
**STEP 5**

Attach the magnets ( 9 ) to the bottom panel ( E ) with the magnets facing to the front as shown, and save their screws to use in step number 8.

**Hardware:**9  x4

Scan QR Code to  
view this step

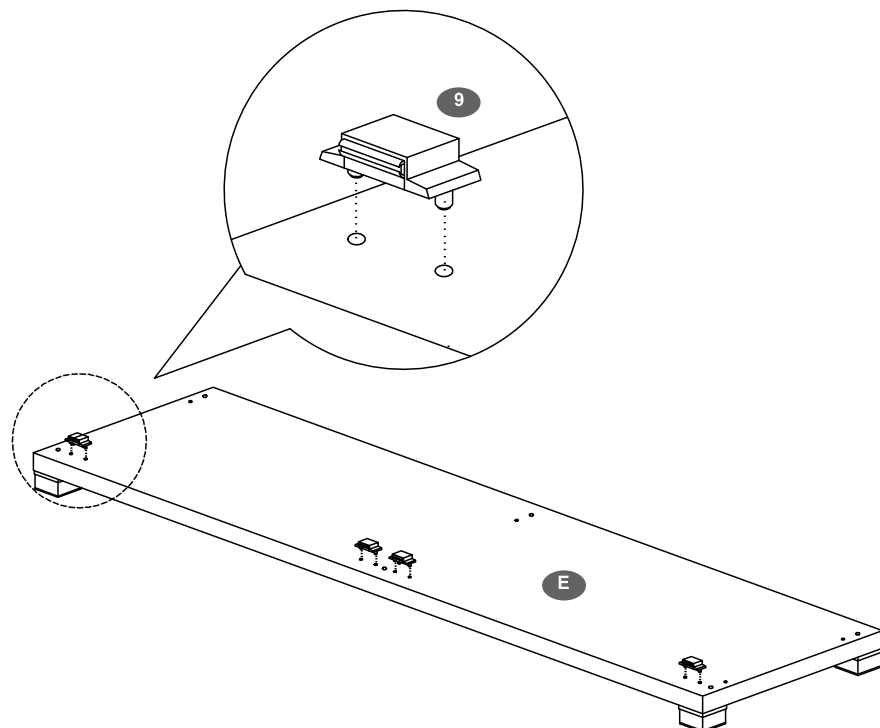

**STEP 6**

Hardware:

4



x2

Scan QR Code to  
view this step

Assemble panel ( A ) to panel ( E ) as shown and secure with screws ( 4 ).

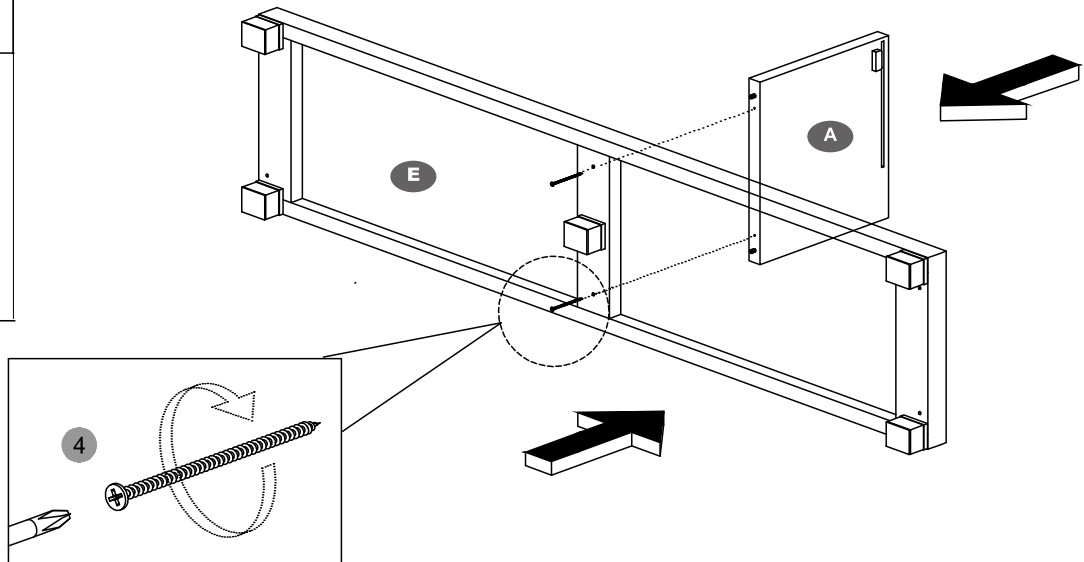
**STEP 7**Scan QR Code to  
view this step

Join the middle panel ( B ) to panel ( A ) ( no screws are needed here ).

Another person should keep holding this part during steps 7 through 10.

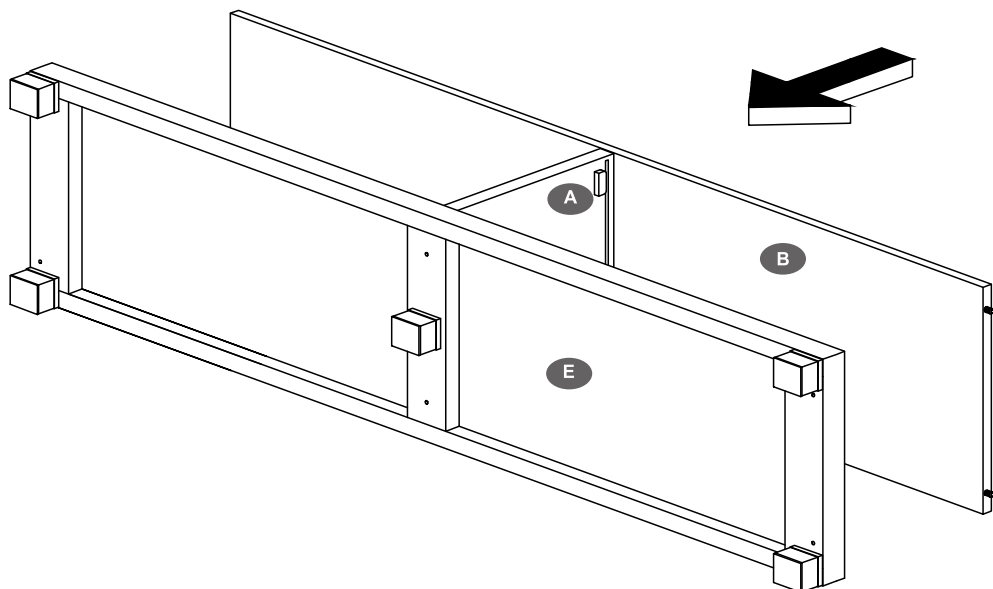

## STEP 8

Attach the screws from the magnet set ( 9 ) to both door panels ( 1 ), then place both metal pins ( 6 ) as shown.

### Hardware:

6  x4

9  x4



Scan QR Code to view this step

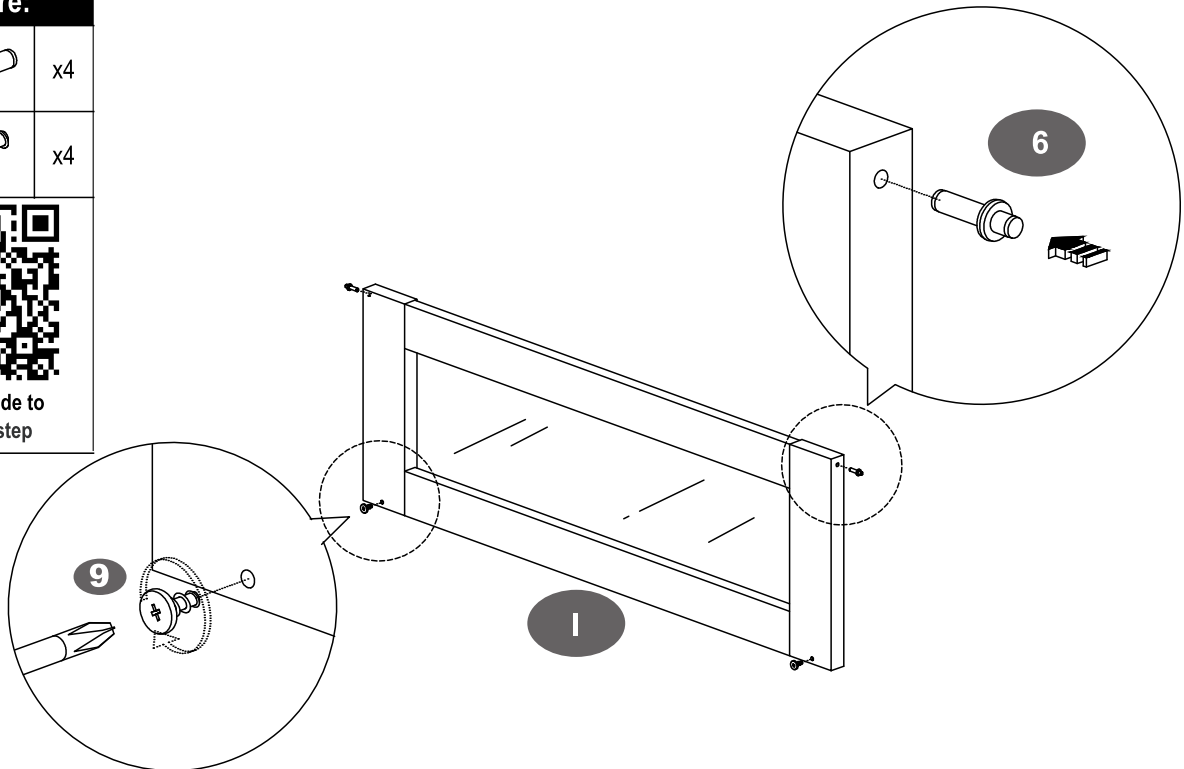

## STEP 9

Place the door ( 1 ) on the left side in between panels ( A ) and ( C ), then secure the panel ( C ) using screws ( 4 ) as shown.

### Hardware:

4  x2

 2 PERSONS REQUIRED



Scan QR Code to view this step

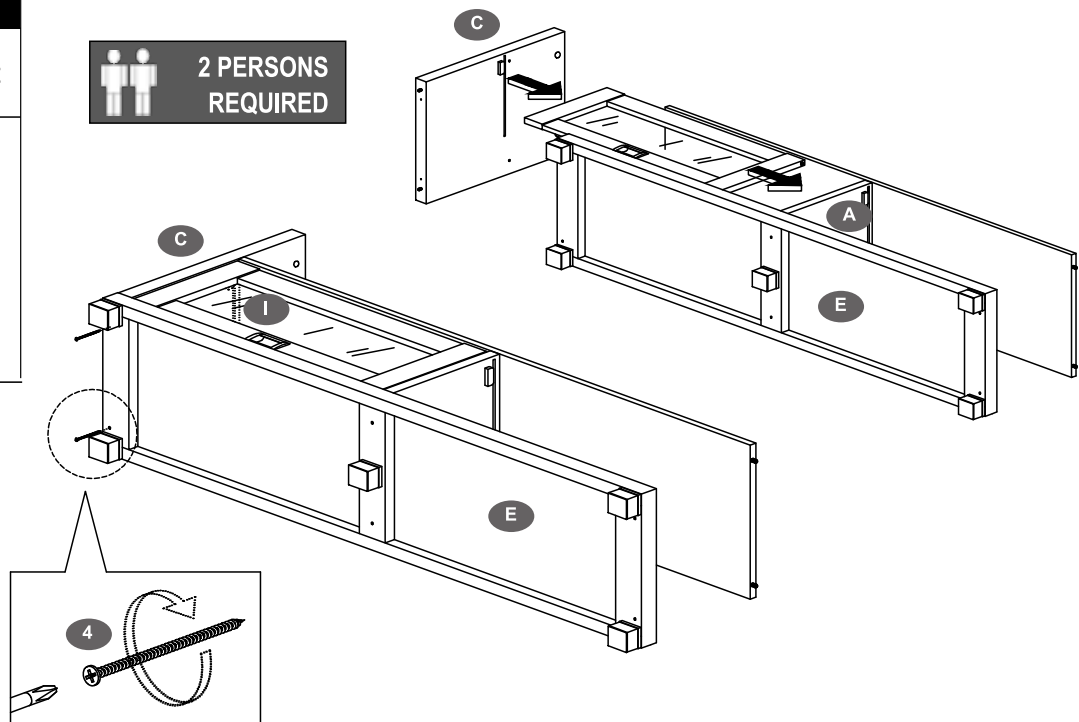



**STEP 10****Hardware:**4  x2

Scan QR Code to view this step

Place the door ( I ) on the right side in between panels ( A ) and ( D ), then secure the panel ( D ) using screws ( 4 ) as shown.

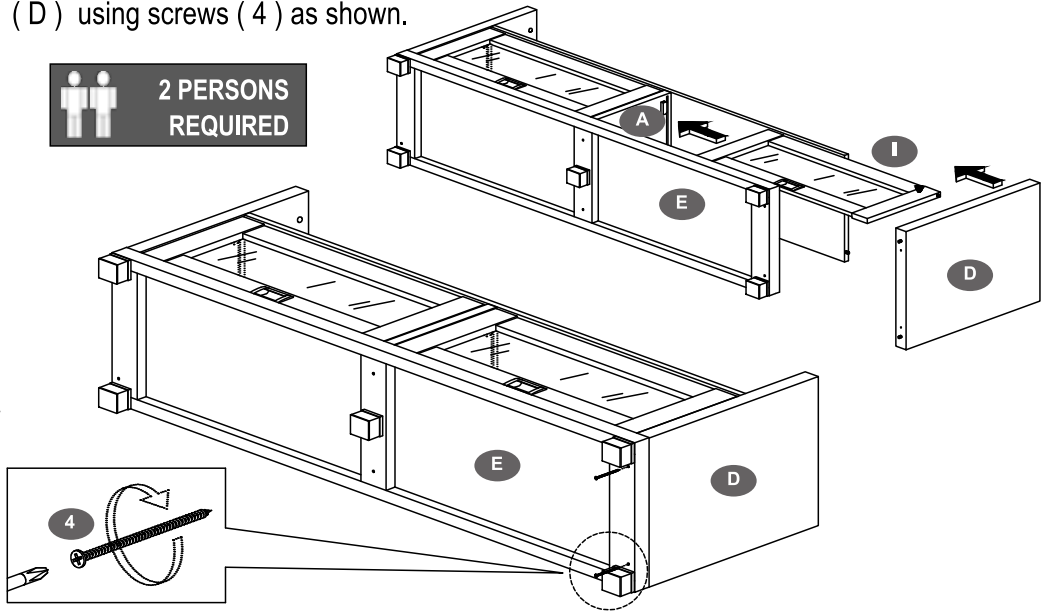
**STEP 11****Hardware:**2  x8

Scan QR Code to view this step

Attach Cam Bolt ( 2 ) to Top Main panel ( H ) as shown.

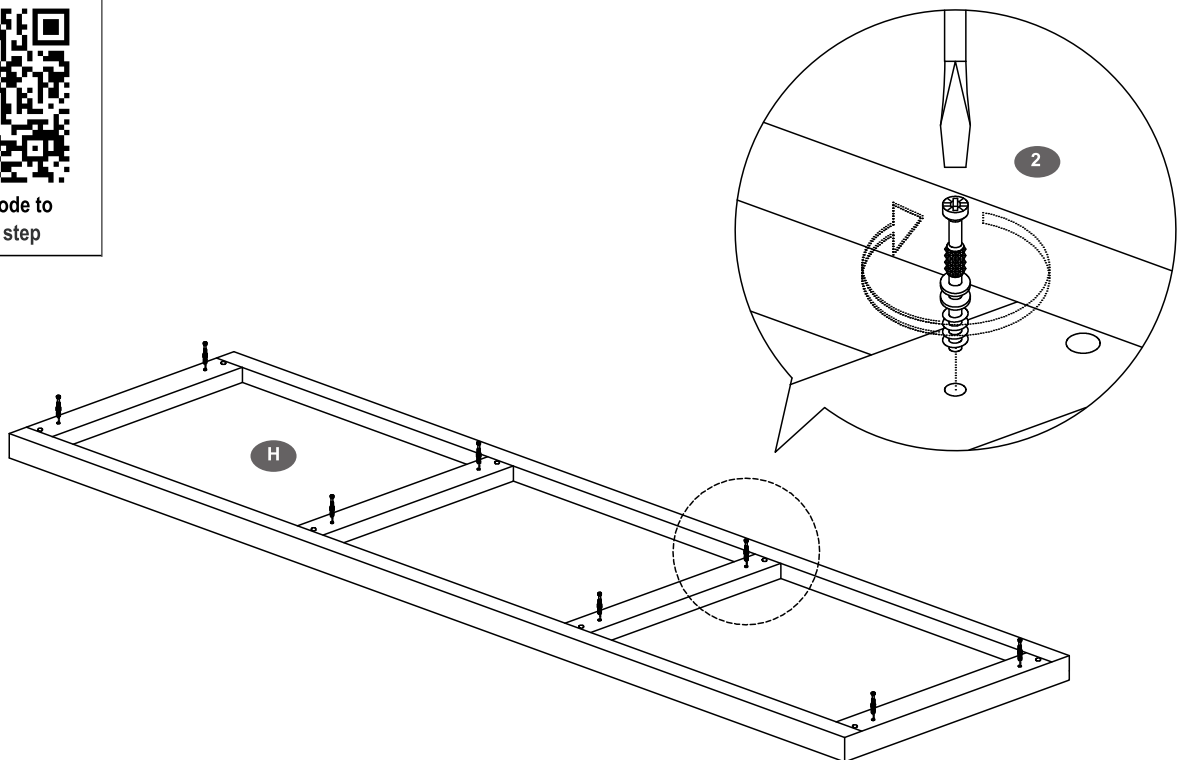

**ATTENTION: Make sure to insert the Cam Bolts in the correct holes, as some other holes are intended for the wooden pins!.**

**STEP 12**

Attach panels ( F ) to panel ( B ) as shown

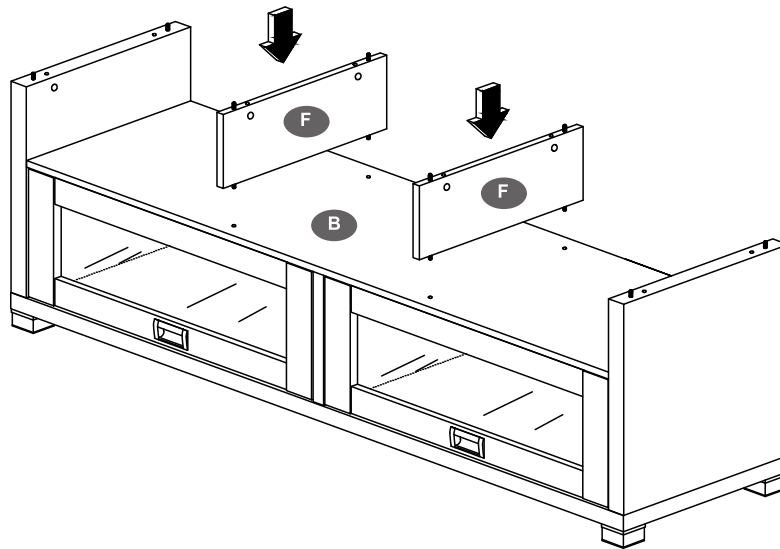
Scan QR Code to  
view this step**STEP 13**

Insert the Cam Locks ( 2 ) into the holes of panels ( C ), ( D ) and ( F ) and align them as it is explained on page 4. Then assemble the main panel ( H ) as shown and as it is explained on page 4.

**Hardware:**

2

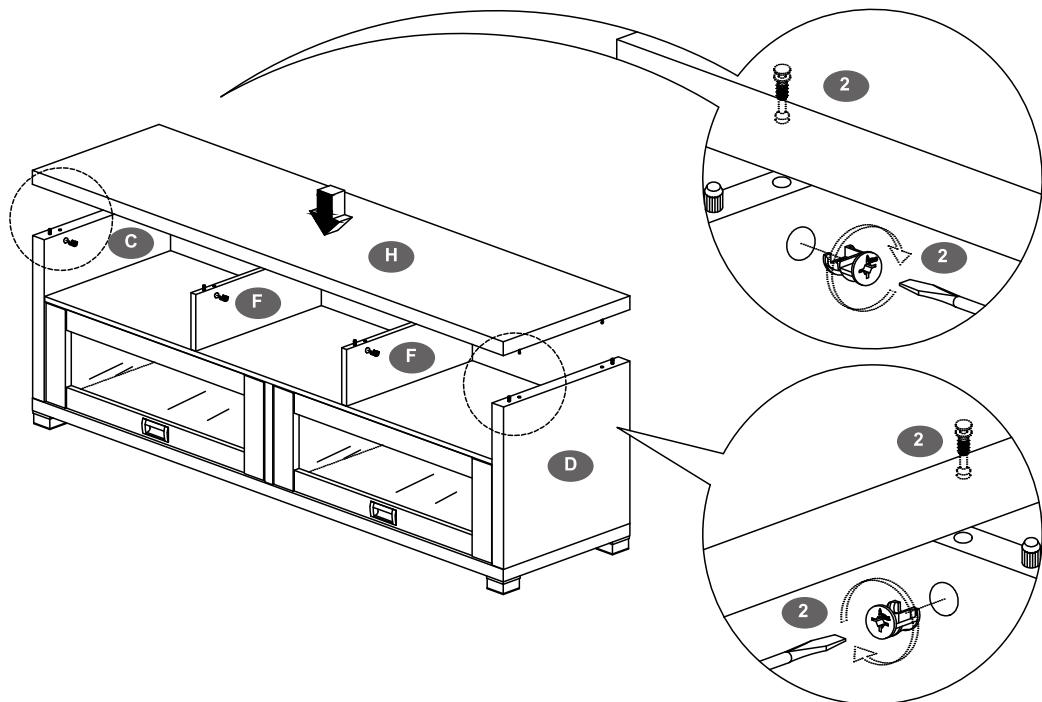

x8

Scan QR Code to  
view this step

**STEP 14****Hardware:**

5



x50

Scan QR Code to  
view this step

Assemble the back panels ( G ) and ( J ) with their finished surfaces facing towards the inside of the stand, using Nails ( 5 ) as shown. The plain surfaces will face the outside.

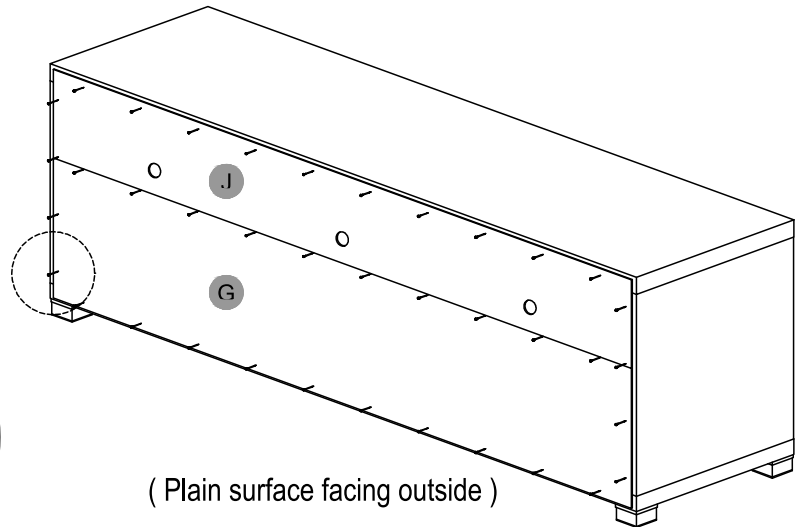
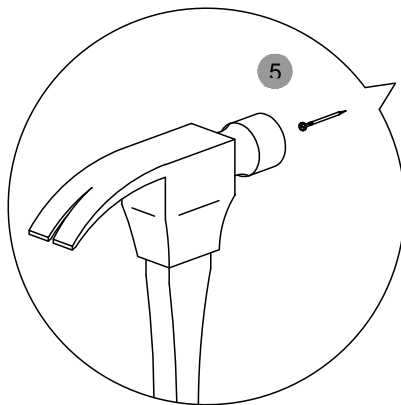
**FINAL STEP****ALL DONE!**

Give yourself a nice pat on the back. You did a great job!

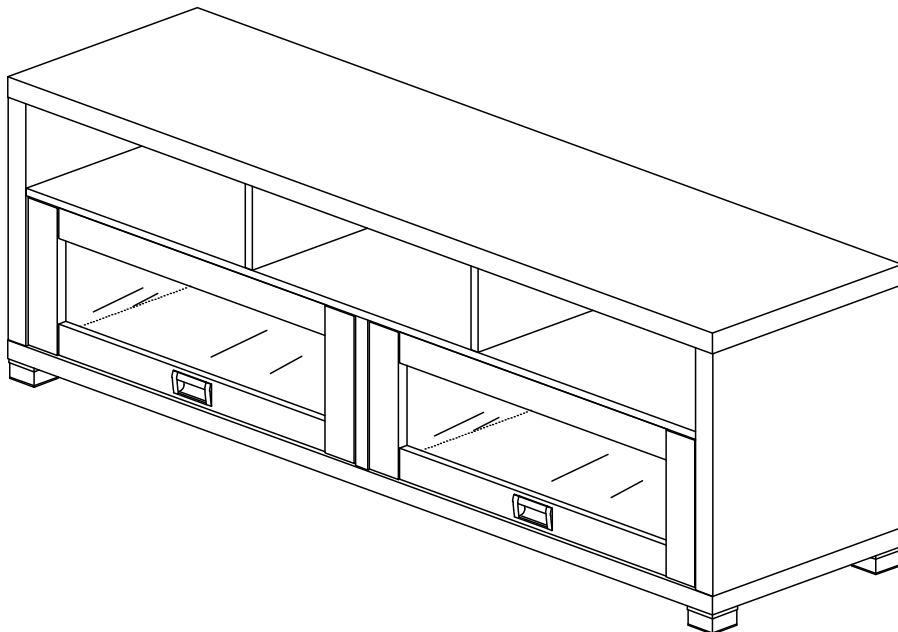

## WEIGHT LIMITS

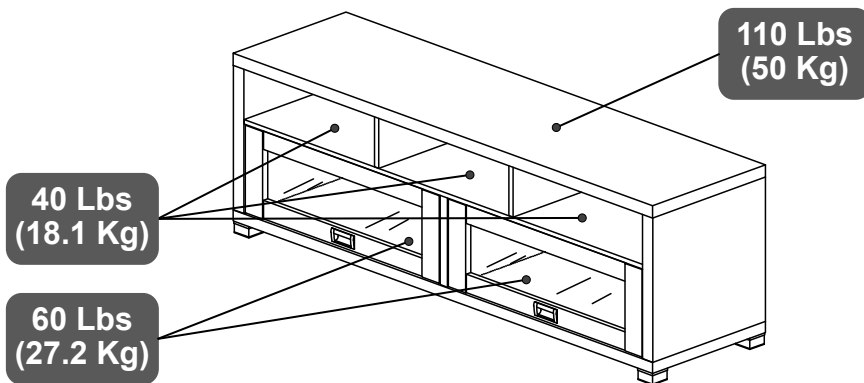

## WARNINGS

- Always pay close attention to small children playing near the unit or when they are watching TV very close to it to prevent tip-over accidents.

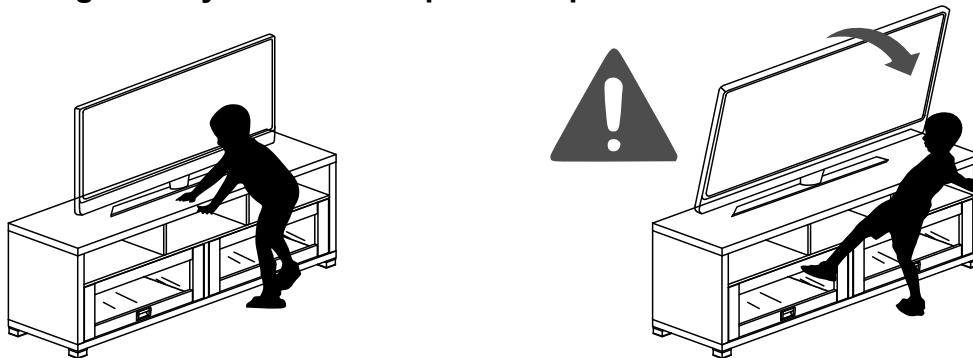

- Do not exceed the indicated weight limits.
- Do not expose the surfaces to direct sunlight or to extreme environmental conditions.
- Do not use solvents or abrasive materials to clean the unit.
- Do not sit on the unit or lean against it.
- Do not allow small children to play over or inside the unit.
- Do not pull, push or drag the unit to move it for more than 1 feet. The unit must be lifted by at least 2 persons when moving in the same or adjacent rooms.
- Before moving the unit, secure or remove your TV and objects that are heavy or might fall off.
- When lifting the unit, use both hands and bend your knees, not your backs.
- Do not use the product if screws are loose or missing, or if you notice damaged parts.
- The warranty does not extend to regular wear and tear, nor the manufacturer assumes liability for damages or consequences due to accidents, incorrect assembly, negligence, improper use, modifications, or not heeding the above warnings.

## CARE AND MAINTENANCE

- Clean the surfaces preferable with a clean cloth damped in a solution of mild soap and water, then dry with a clean towel.
- If you decide to use a cleaning agent, test first on an area hidden from view such as underneath the tabletop.
- Every 4 months, inspect the unit completely and make sure that all screws are tighten.
- When transporting the unit to places far away, protect and secure the unit to avoid damage in transit.

**TECHNI MOBILI WARRANTY****TV Stand/Entertainment Center: 2 YEAR WARRANTY**

RTA Products, LLC warrants to the Original Purchaser who acquired a new product from RTA Products or its authorized resellers that this product will be free from defects in its workmanship and materials, under normal use and service conditions, as described herein. "Defects" as used in this warranty, is defined as any imperfections that impair the use of the furniture or product. RTA products will repair or replace, at its option, without charge to the original purchaser 'other than freight from purchaser to RTA Products, only the defective products or parts for a period of TWO (2) Years.

Replacement parts can only be supplied if parts are available. Items out of production may be unavailable. This warranty will be effective for the applicable time period beginning the date of purchase on your original sales receipt. RTA product's obligation under this warranty is limited to repairing or replacing products or parts as provided herein. This product has been designed for and is intended for office and home-office use only. This warranty is Original Purchaser's sole remedy for product defects, and this warranty does not extend to any product, or damage to any product, caused by or attributed to abuse or misuse, products used for commercial or rental purposes, use modifications of, or attachments to the product, and products or parts not used, maintained, or extended hereunder is in lieu of any and all other warranties, express or implied, including without limitations any implied warranty or merchantability or of fitness for a particular purpose. Please note, all desks made with PVC Laminate surface should not be exposed to direct sunlight, as it may damage the material. Damage of this nature is not covered under this warranty.

RTA Products will not be responsible for indirect, special, incidental or consequential damages. This warranty is limited to merchandise purchased in the Continental United States, excludes AK, HI and PR. Some States do not allow the exclusion or limitation of incidental or consequential damages, so the above limitations or exclusions may not apply to you. This warranty gives you specific legal rights. You may also have other rights that may vary from state to state.

To file a Claim within the 48 contiguous United States: Email us to [warranty@rtaproducts.com](mailto:warranty@rtaproducts.com) to explain the defect and provide your name, address, phone number, model number of our product, date and place, and proof of purchase. Please provide pictures of the damage or defect.

If we determine that a replacement will remedy the situation, and in order to determine the extent or the cause of the defect, purchaser may be requested to send the part in question at purchaser's expense. Once we receive the part, we will examine it and determine whether the claim is valid (or not), and then proceed to send the replacement. We will ship the replacement at our expense.

Replacement Parts for International Customers & AK-HI-PR orders:

RTA Products will replace the part free of charge, while the customer is responsible for shipping costs plus any International local taxes or duties.