



KITCHEN CART

MODEL RTA-858KC

ASSEMBLY INSTRUCTIONS

REV-1-FP-7940-0324

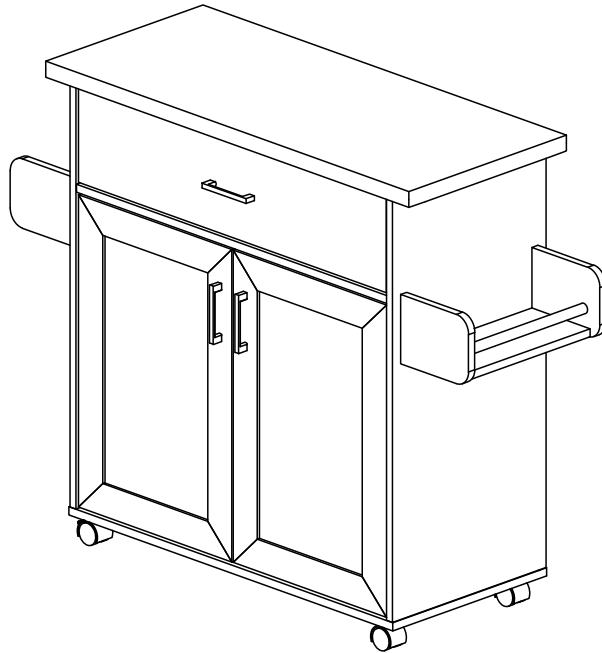

Thank you for purchasing our product



Do a quick inventory of all the parts and hardware listed below.



For Support, assembly questions & Replacement Parts within the 48 Contiguous United States:

Please email us at: support@rtaproducts.com



Replacement Parts for International Customers & **AK-HI-PR** orders: RTA Products will replace the part free of charge, while **the customer is responsible for shipping costs plus any International local taxes or duties.**

MAIN PARTS LIST

A: Tabletop

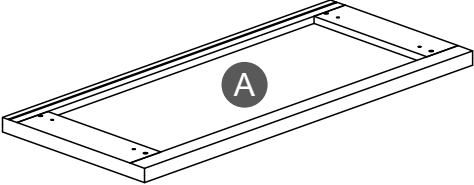

B: Lower panel

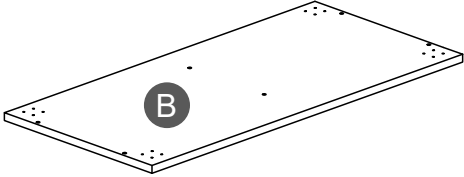

C: Left side panel

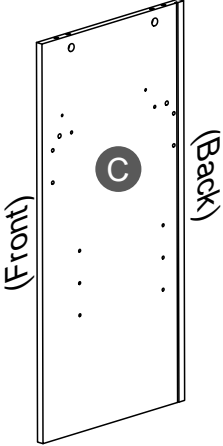

D: Right side panel

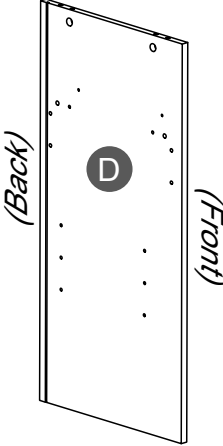

E: Partition panel

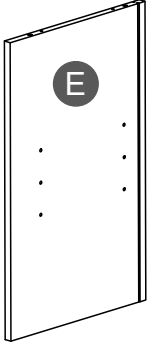

F: Front cross panel

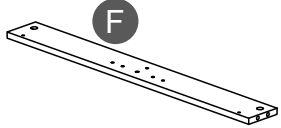

G: Adjustable shelf (x2)

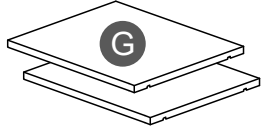

H: Left rack back panel



I: Left rack front panel



J: Right rack front panel





K: Right rack back panel



(Continue on next page)

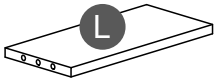
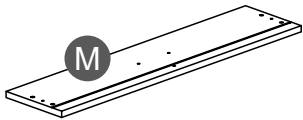
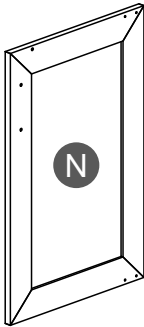
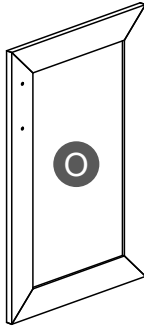
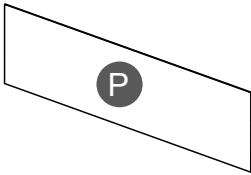
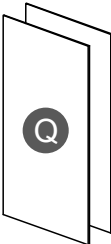
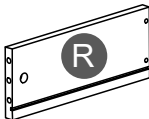
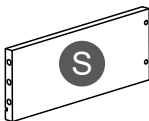
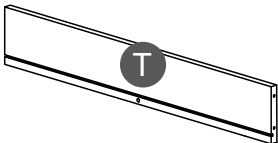

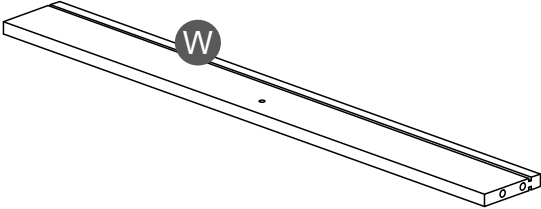



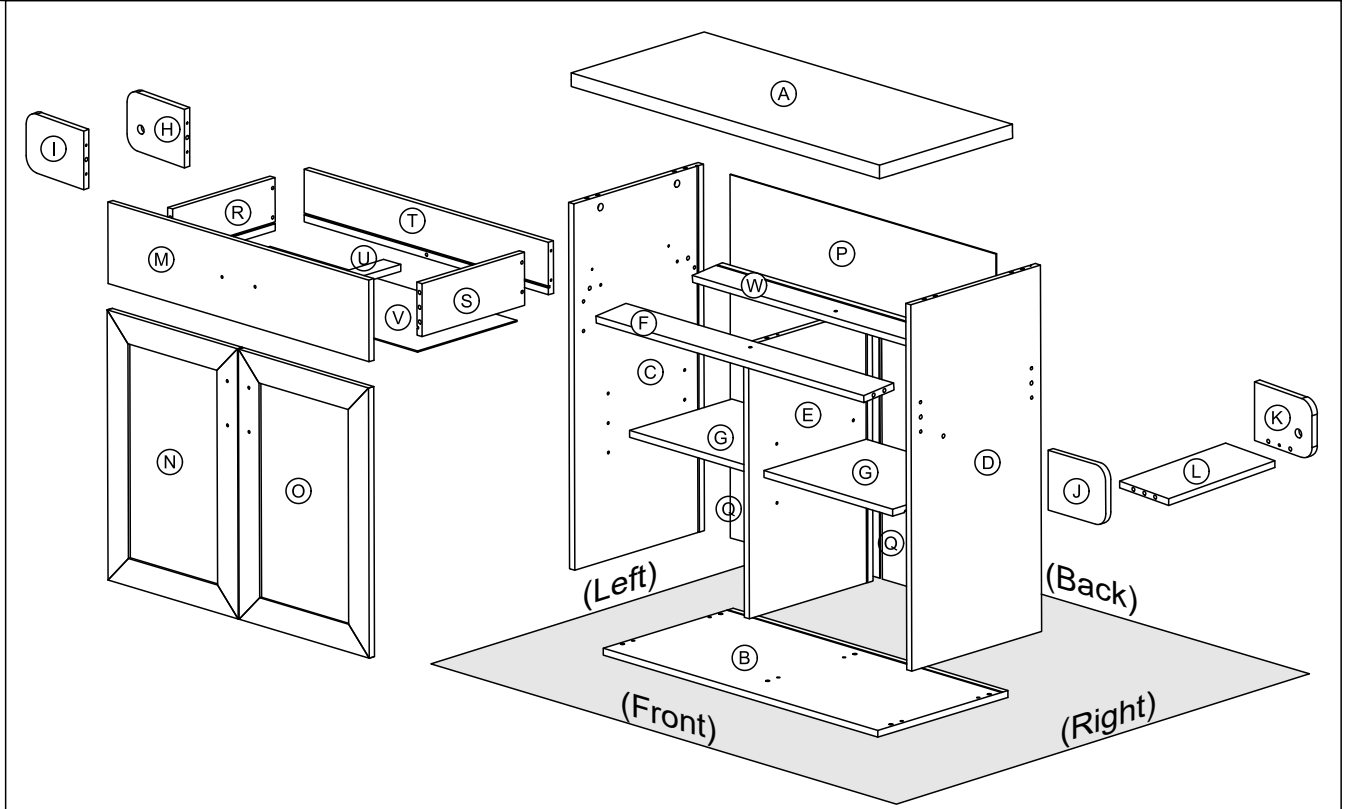

MAIN PARTS LIST (Cont.)

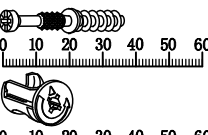

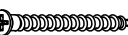

<p>L: Right rack lower panel</p> 	<p>M: Drawer front panel</p> 	<p>N: Left door</p> 	<p>O: Right door</p> 
<p>P: Upper back panel</p> 	<p>Q: Lower back panel (x2)</p> 	<p>R: Drawer left panel</p> 	<p>S: Drawer right panel</p> 
<p>T: Drawer back panel</p> 	<p>U: Drawer support panel</p> 	<p>V: Drawer bottom panel</p> 	
		<p>W: Back cross panel</p> 	

MAIN PARTS LAYOUT (For reference)

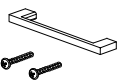
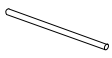

HARDWARE LIST

PART	SIZE / DESCRIPTION	QTY	ITEM
1	Ø8x25 Wooden dowel	30	
2	M6x23 Bolt with Ø15x12 Cam lock (Minifix)	13 Sets	
3	M5x8 (Euro)	4	
4	M5x40	21	
5	M3x16	12	
6	M3.5x16	28	
7	Ø17 Cam lock cap	2	
8	Ø5x15 Metal pin	8	
9	PVC Door hinge	4	

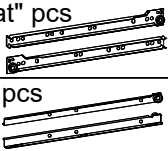
PART	SIZE / DESCRIPTION	QTY	ITEM
10	Magnet with M6x10mm flat head screw	2 Sets	
11	Z Plastic bracket	6	
12	96mm handle with two M3.6x20 screws	3 Sets	
13	Ø19 x 330mm Metal rail	2	
14-L	Plate caster, Locking	2	
14-N	Plate caster, Non-Locking	2	
15	300mm (12") Drawer metal sliders	1 Set of 4 pcs	

NOTE: This product does not include any tools, you will need to have the following available during assembly: 1. Hammer, 2. Phillips screwdriver or power driver with Phillips bits.

BEFORE YOU START THE ASSEMBLY, PLEASE READ THE FOLLOWING TIPS AND WARNINGS.

- Do not discard this manual or any of the packaging material until the unit is completely assembled.
- Please read the assembly instructions thoroughly and follow step by step.



- The assembly might require of 2 persons for certain steps. Before you start the installation, make sure there is someone else nearby to help you.



- Make sure you understand which hardware will be used on each step. Using the wrong size of screw, bolt or pin might strip the threads or cause damage to the part in which it is being used.

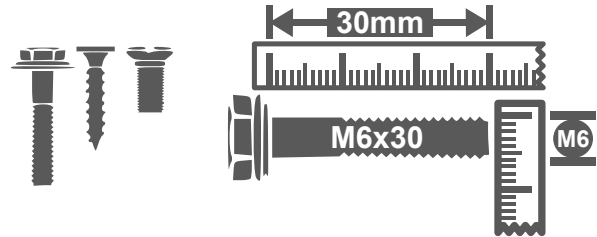

- To avoid misalignments, always leave the screws loosely and do not tighten them until all the pieces are positioned correctly.
- Do not overtighten or force the screws as they might break, strip, damage the threads of the holes, or get stuck inside the parts.

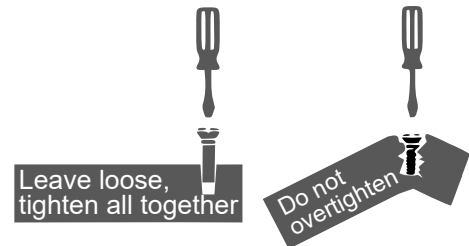

- If the hole seems to small for the screw, make sure you are using the correct size of screw and/or that you are installing it in the correct hole.



- Sometimes on the wood panels the laminate or material might be covering the hole partially or entirely, if there is no visible hole or if it looks too small, pass and press the tip of your finger over the area to feel its indentation, and carefully pierce the laminate to uncover the hole underneath.

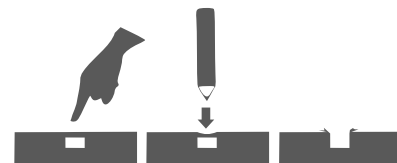

- Please be kind to our planet, when done with the assembly, recycle any of the packaging materials that is accepted by your city or recycling service.



Thank you!



THE ASSEMBLY STEPS START ON NEXT PAGE

CAM BOLT AND CAM LOCK TUTORIAL

**THE INSTRUCTIONS BELOW
ARE NOT ACTUAL ASSEMBLY STEPS**

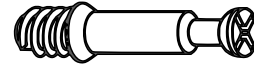

**This unit uses cam bolts and locks (also known as mini fixes).
If you are not familiar with this kind of hardware, the below is a tutorial
that explains how to use them on the steps where they are required.**

1. Screw the bolt into the indicated hole on the panel indicated in the assembly step.

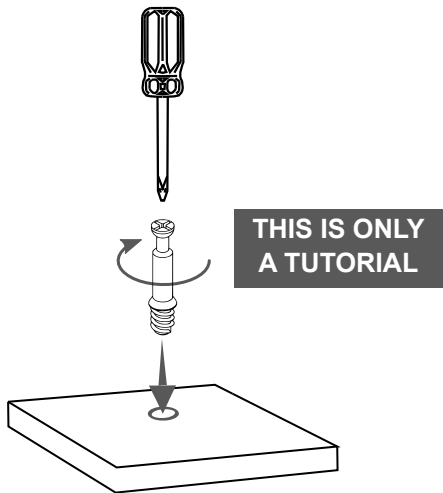

2. Join the other panel (with the big hole) to the panel with the bolt. If it comes with the cam locks already pre-installed, make sure to align them to receive the bolt's head (refer to point 3). There might be a very small gap between the panels which is normal.

If the cam locks come pre-in stalled, make sure they are aligned (see point 3).

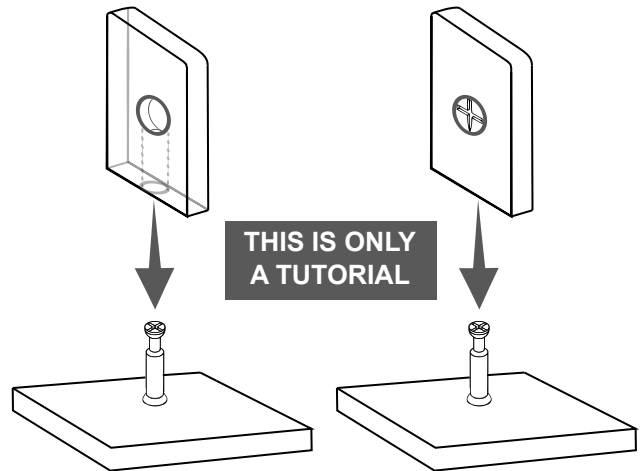

3. Insert the cam lock on the panel with the big hole making sure it goes aligned to receive the bolt's head.

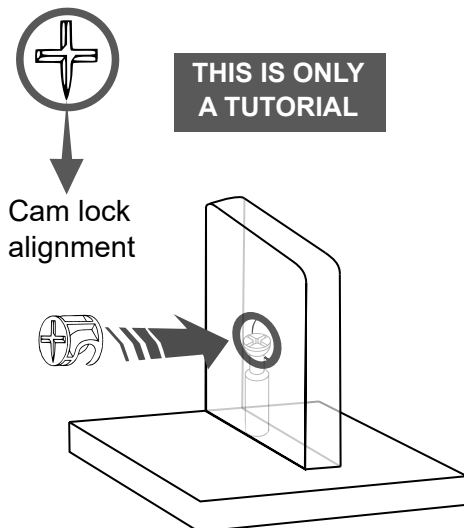

4. Use a Phillips screwdriver to turn the cam lock clockwise. This will lock the panels together and also will close any gaps.

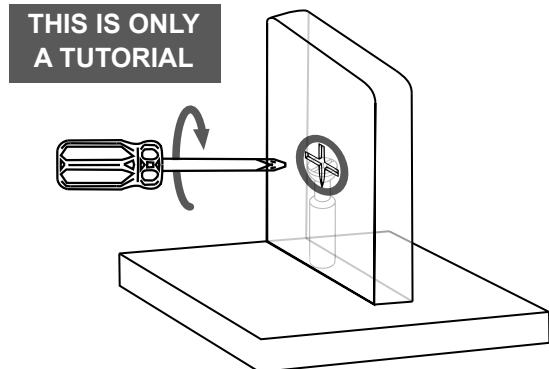

ASSEMBLY STEPS

WE RECOMMEND TO PLACE THE PIECES OVER BLANKETS OR TABLECLOTHS TO PROTECT THEIR FINISH DURING ASSEMBLY.

STEP 1

Hardware

1  30 Pcs
Ø8x25mm

Tools (Not included)



Insert the dowels 1 into the indicated holes on panels C, D, E, F, H, I, J, K, L, R, S and W.

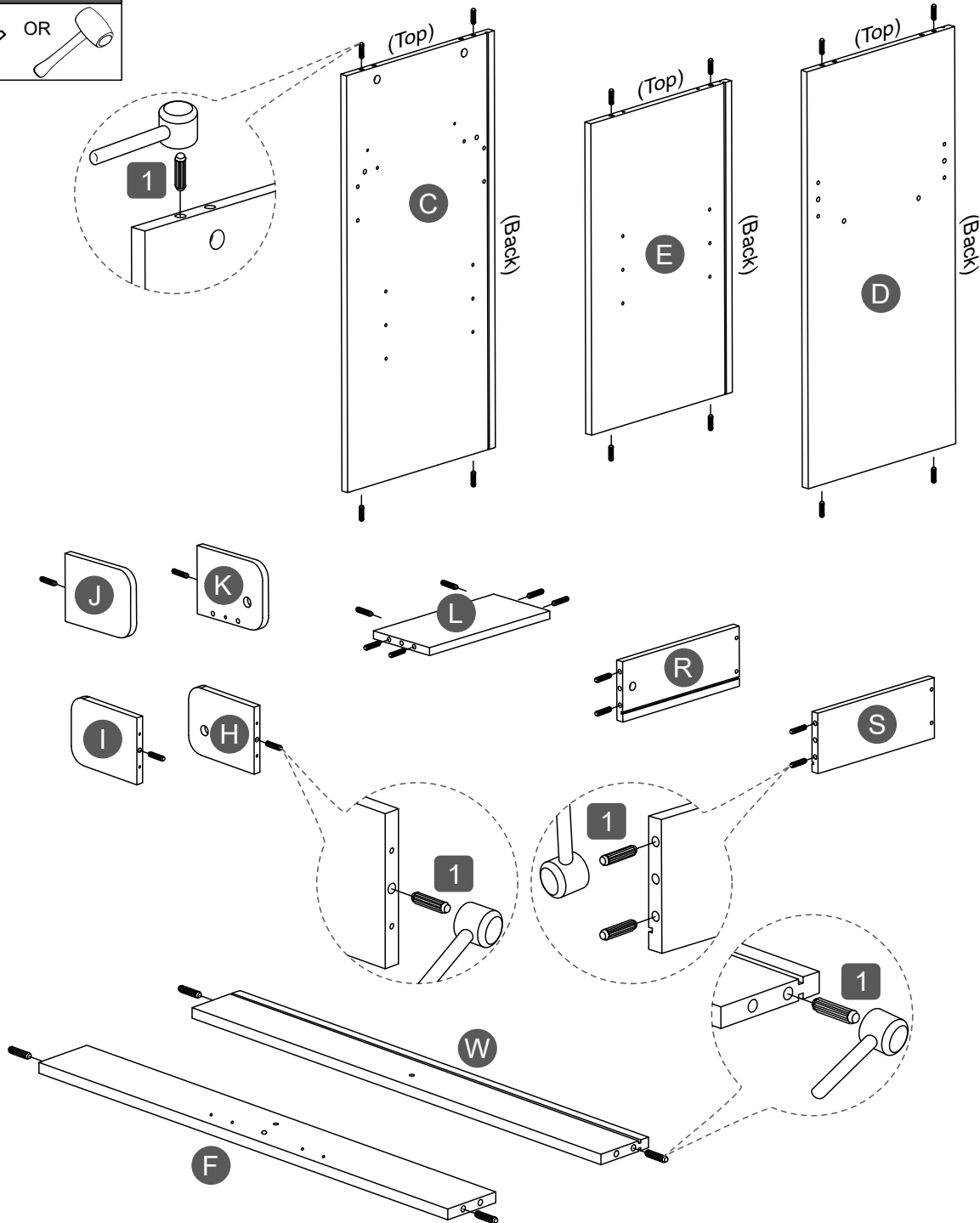

STEP 2

Hardware

2		13 Pcs
M6x23		

Tools (Not included)

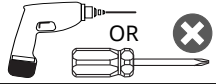

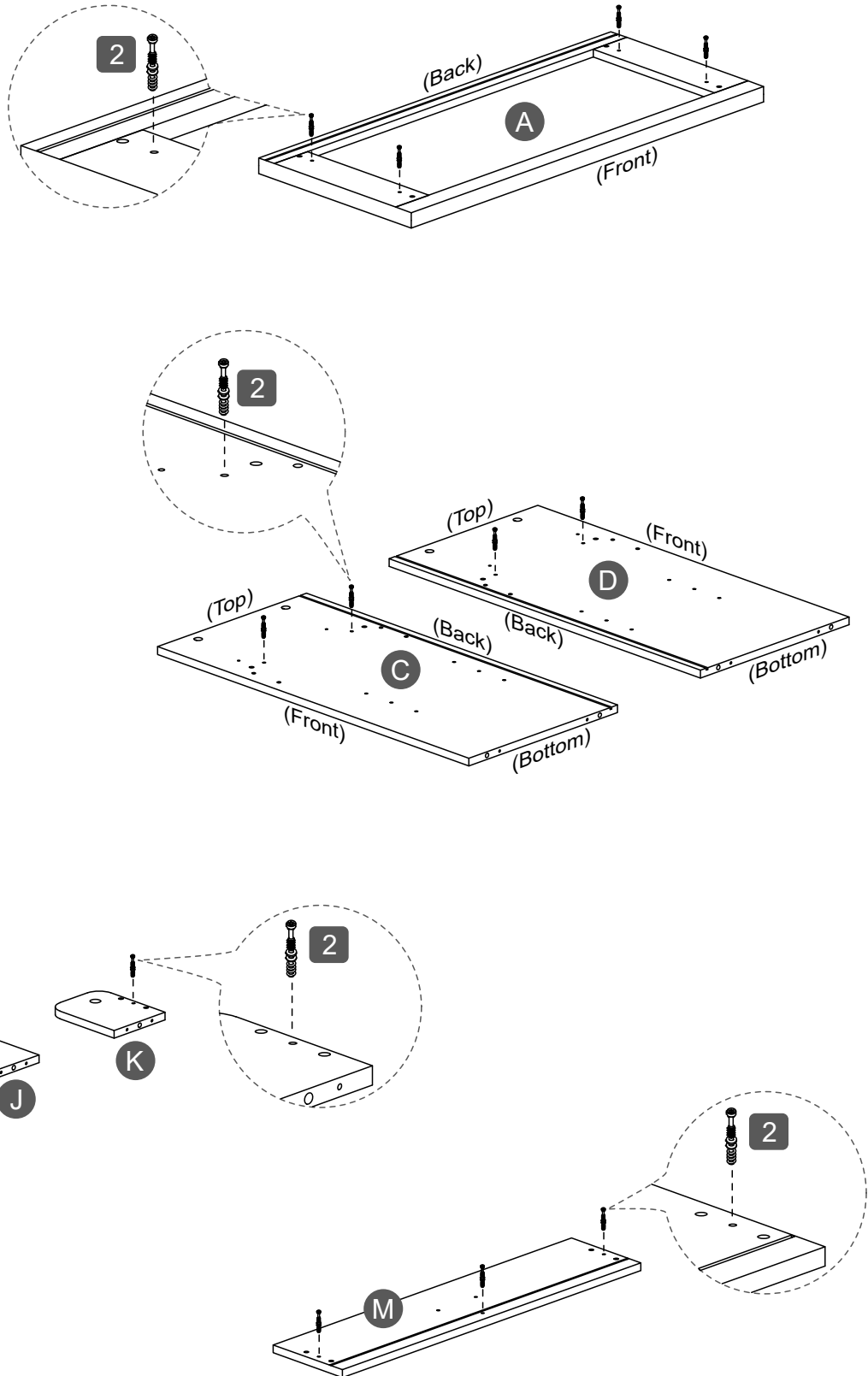

Attach the bolts 2 into the indicated holes on panels A, C, D, J, K and M.



STEP 3

Hardware

3	 M5x8	4 Pcs
15	 "Flat" Sliders only	2 Pcs

Tools (Not included)

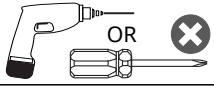

- **FIRST** take the slider set **15** and put aside the "L" shaped ones as they won't be used until step **13**. In this step you will use only the "Flat" pieces.
- **THEN** install the sliders **15** to the side panels **C** and **D** with the Euro screws **3**.

NOTE:

- The wheels on the sliders face towards the front of the panels with 2 holes above them.

FIRST

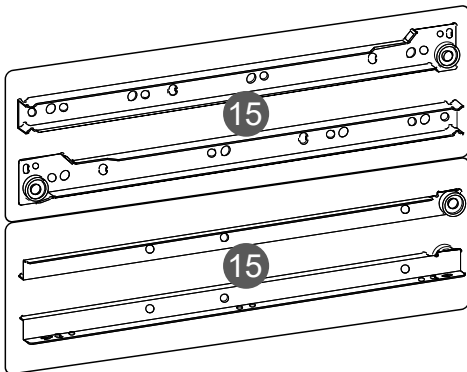

These 2 "flat" pieces will be used in this step.

Put aside these 2 "L" shaped pieces; they won't be used until later.

THEN

Attach at the **FRONT** first ,on 4th hole

Afterwards, attach on the hole that matches at the back.

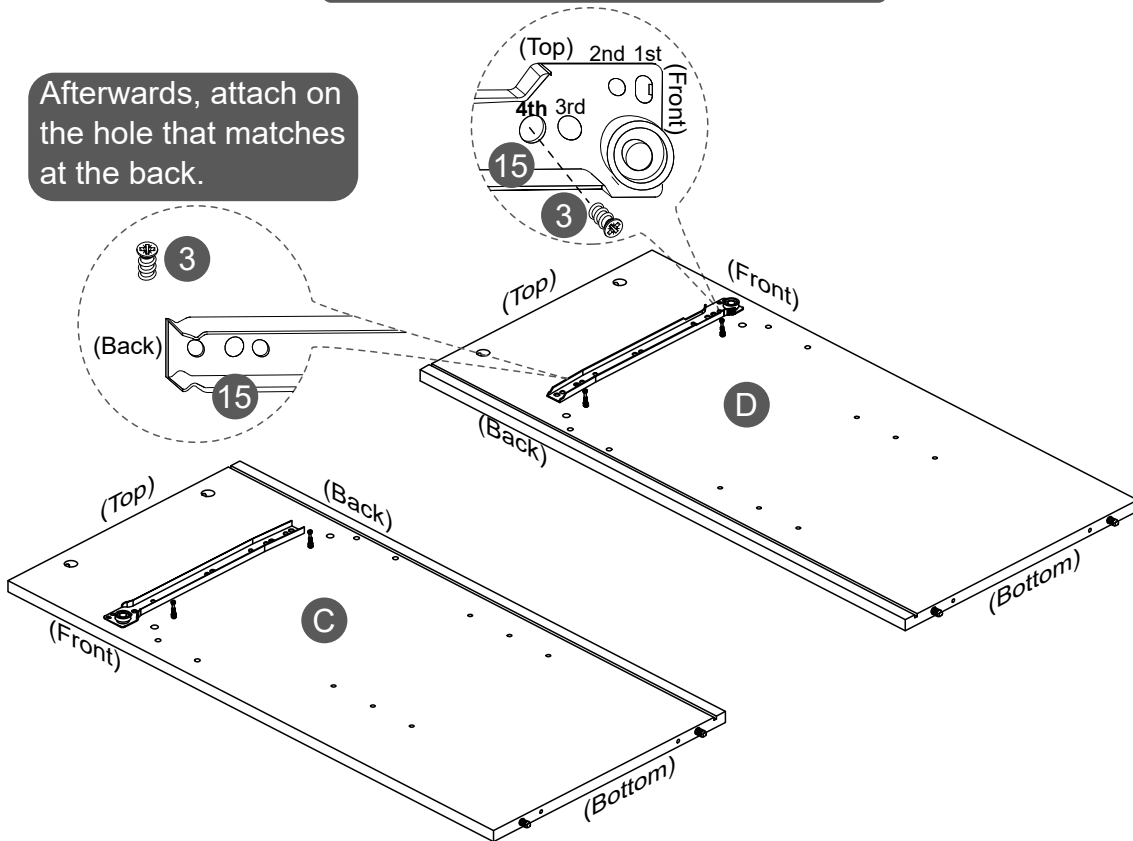

STEP 4

Hardware

2		2 Pcs
Ø15x12		

Tools (Not included)

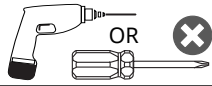

- FIRST assemble the panel L to panel K with a cam lock 2 as explained in the TUTORIAL page.
- THEN place the tube 13 and assemble the panel J to panel L with cam lock 2.

FIRST

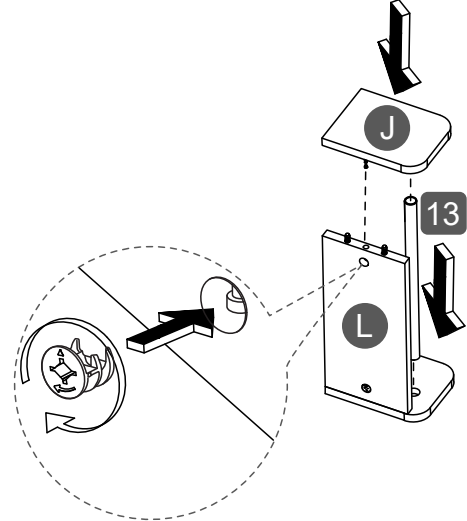
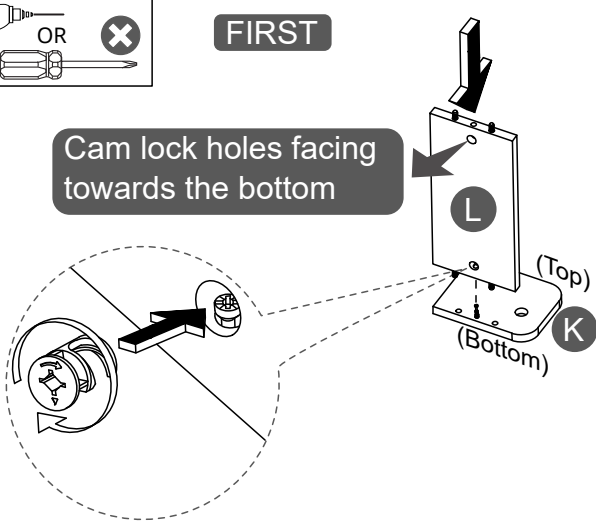

STEP 5

Hardware

4		8 Pcs
M5x40		

Tools (Not included)

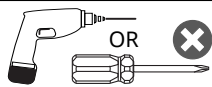

- FIRST assemble the panels H and I with the metal rail 13 to the panel C with screws 4 for the left rack of the unit.
- THEN assemble the panels J and K to the right panel D with screws 4 for the right rack of the unit.

FIRST

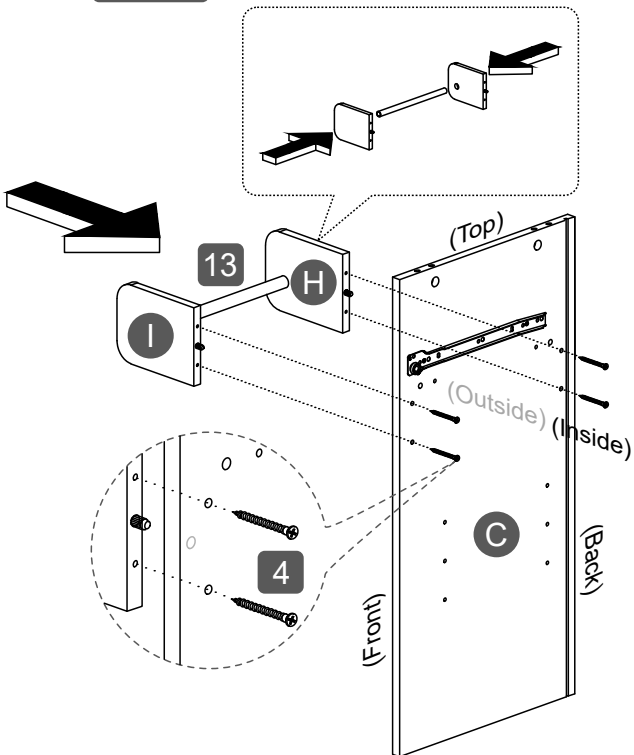

THEN

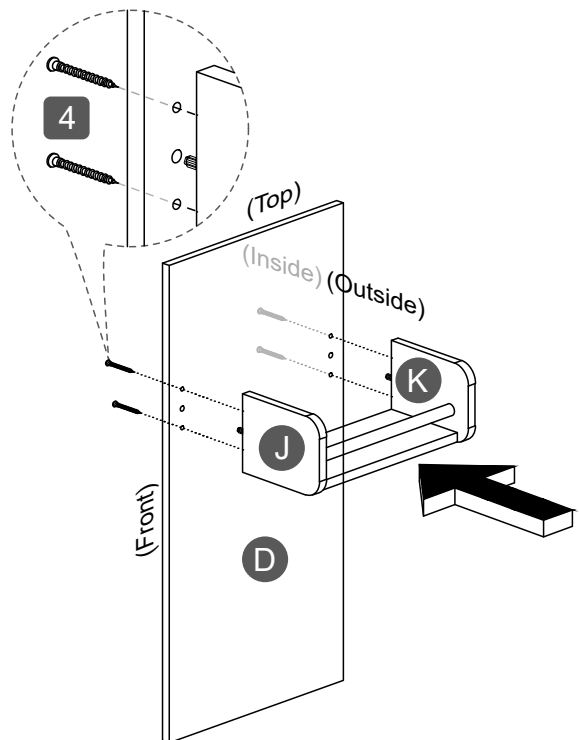

STEP 6

Hardware

10		2 Pcs
Magnet		

Tools (Not included)

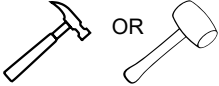

Please use only if pushing by hand is difficult.

Install the magnets **10** to panel **F** by pushing them down (the magnet screws won't be used until later, please set them aside). Please note the orientation of the magnet plates: they must go facing towards the outside.

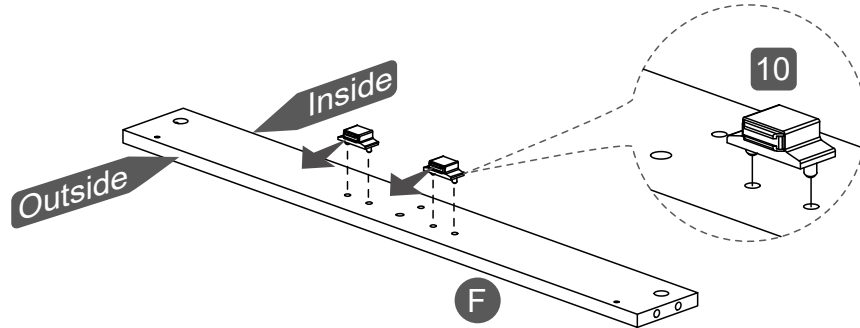

STEP 7

Hardware

2		4 Pcs
Ø15x12		

Tools (Not included)

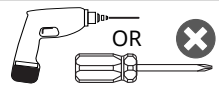

- **FIRST** assemble the panels **F** and **W** to the left side panel **C** with cam locks **2** as explained in the TUTORIAL page. Panel **F** goes at the front and panel **W** at the back.
- **THEN** assemble the right side panel **D** to the panels **F** and **W** with cam locks **2**.

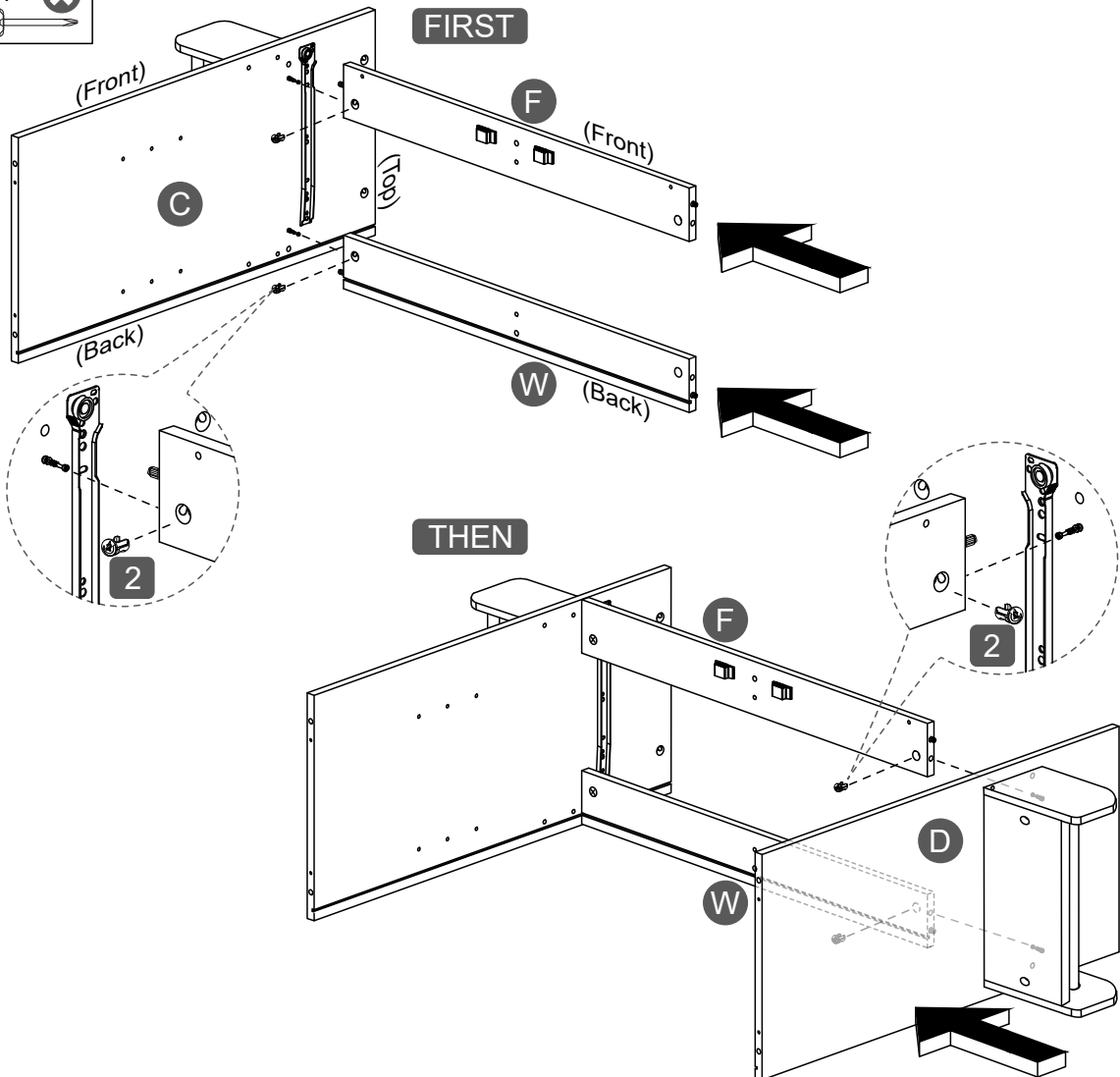

STEP 8

Hardware

4		2 Pcs
	M5x40	

Tools (Not included)

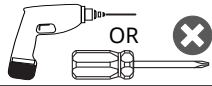

Assemble the partition panel **E** to panels **F** and **W** with screws **4**.

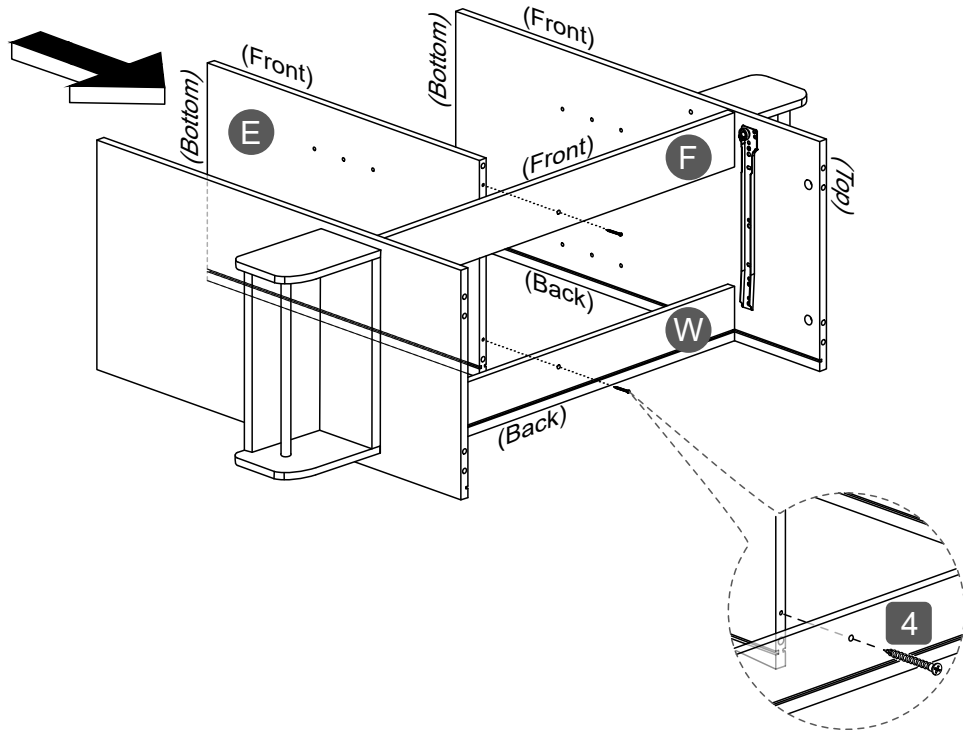

STEP 9

Hardware

6		16 Pcs
	M3.5x16	

14-L		2 Pcs
	Locking	

14-N		2 Pcs
	Non-Locking	

Tools (Not included)

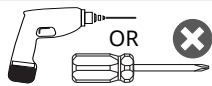

- **FIRST**, install the Locking casters **14-L** to the lower panel **B** on the front sets of holes with screws **6**.
- **THEN**, install the Non-Locking casters **14-N** on the back sets of holes with screws **6**.

FIRST

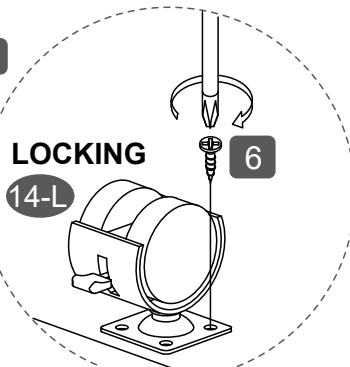

THEN

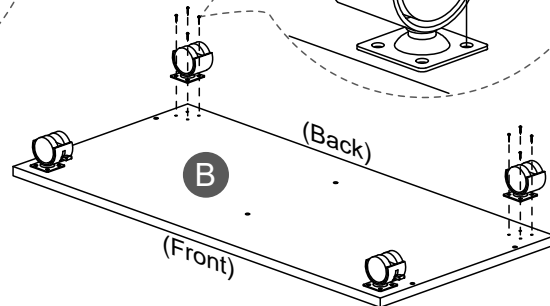
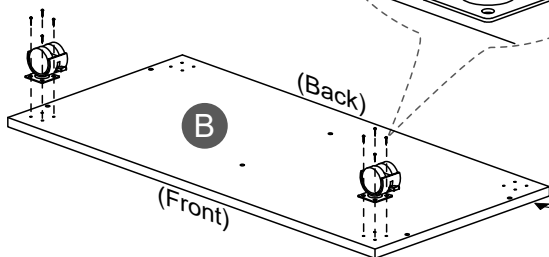
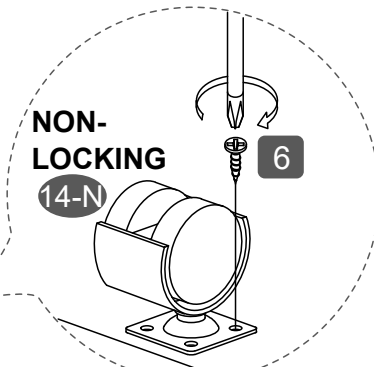

(For reference: The groove is located on the other side at the back)

STEP 10

This step requires of 2 persons



Hardware

4



M5x40

6 Pcs

Tools (Not included)

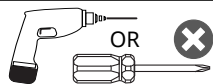

- **FIRST**, insert the lower back boards **Q** through the grooves of panels **C**, **D** and **E** respectively, and into the groove of panel **W**.
- **THEN**, and with the help of another person, assemble the lower panel **B** to the panels **C**, **D** and **E** with screws **4**.
- **LASTLY**, and with the help of another person, bring the unit upright.

FIRST

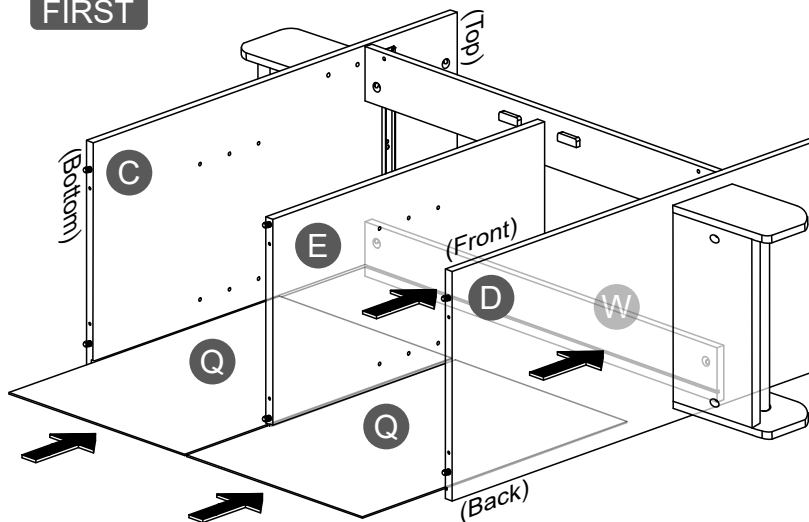

THEN

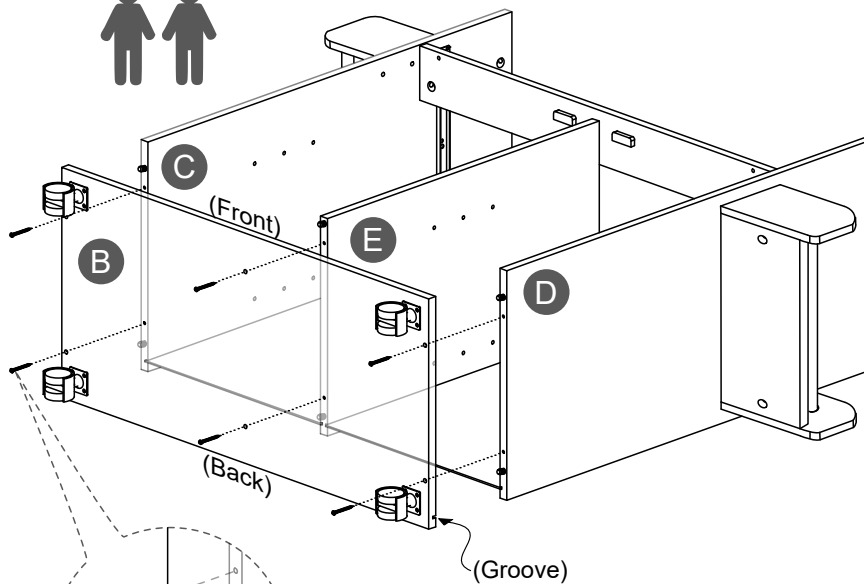

LAST

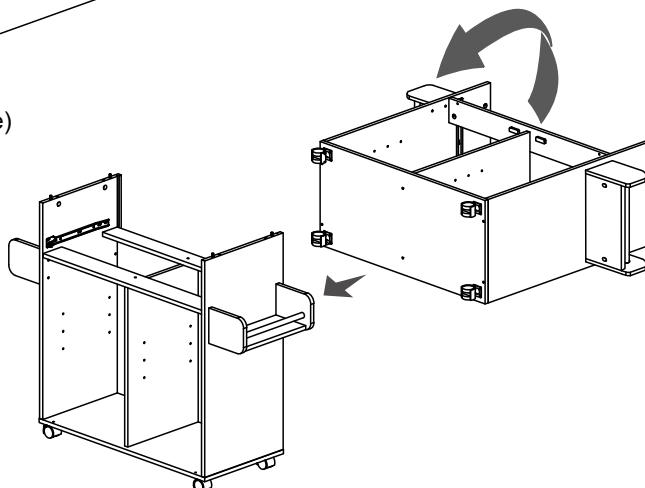

STEP 11

This step
requires of
2 persons



Hardware

2



Ø15x12

4 Pcs

Tools (Not included)

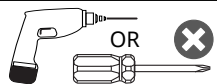

- **FIRST**, insert the upper back panel **P** through the grooves of panels **C** and **D**, and into the groove of panel **W**.
- **THEN**, and with the help of another person, assemble the tabletop **A** to panels **C** and **D** with cam locks **2** as explained in the TUTORIAL PAGE.

FIRST

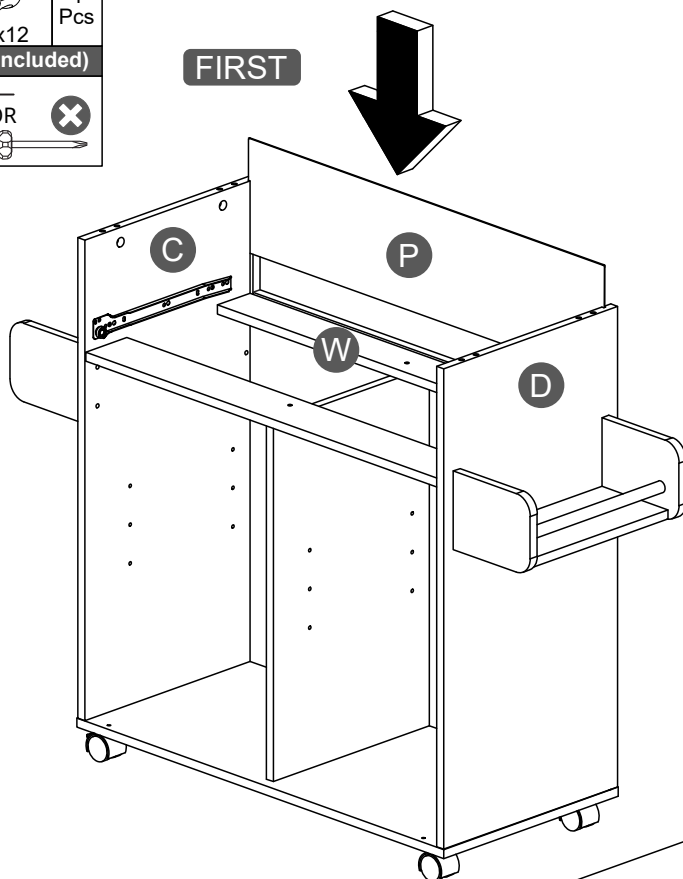



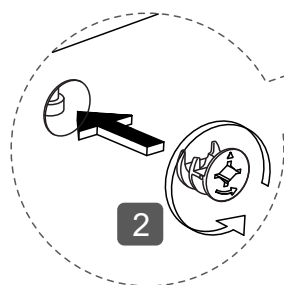
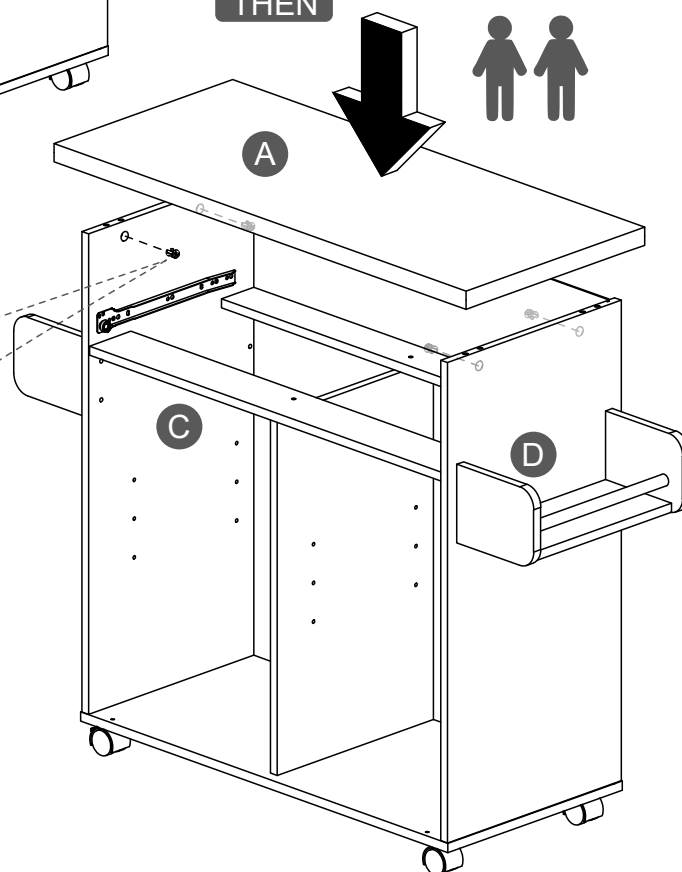

THEN



STEP 12

Hardware

2		3 Pcs
4	 M5x40	5 Pcs
7		2 Pcs
12		1 Set

Tools (Not included)

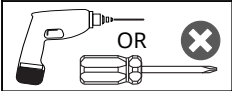

- **FIRST**, assemble the drawers' side panels **R**, **S**, and also the bottom support **U** to the front panel **M** with cam locks **2** as explained in the TUTORIAL PAGE.
- **THEN**, slide the bottom panel **V** through the grooves of the side panels **R** and **S**, and into the groove of the front panel **M**.
- **THEN**, assemble the back panel **T** to the side panels **R**, **S** and the bottom support **U** with screws **4**.
- **LASTLY**, attach the handle **12** to the front panel **M** with its own screws **12**, and cover the cam locks on the side panels **R** and **S** with **7**.

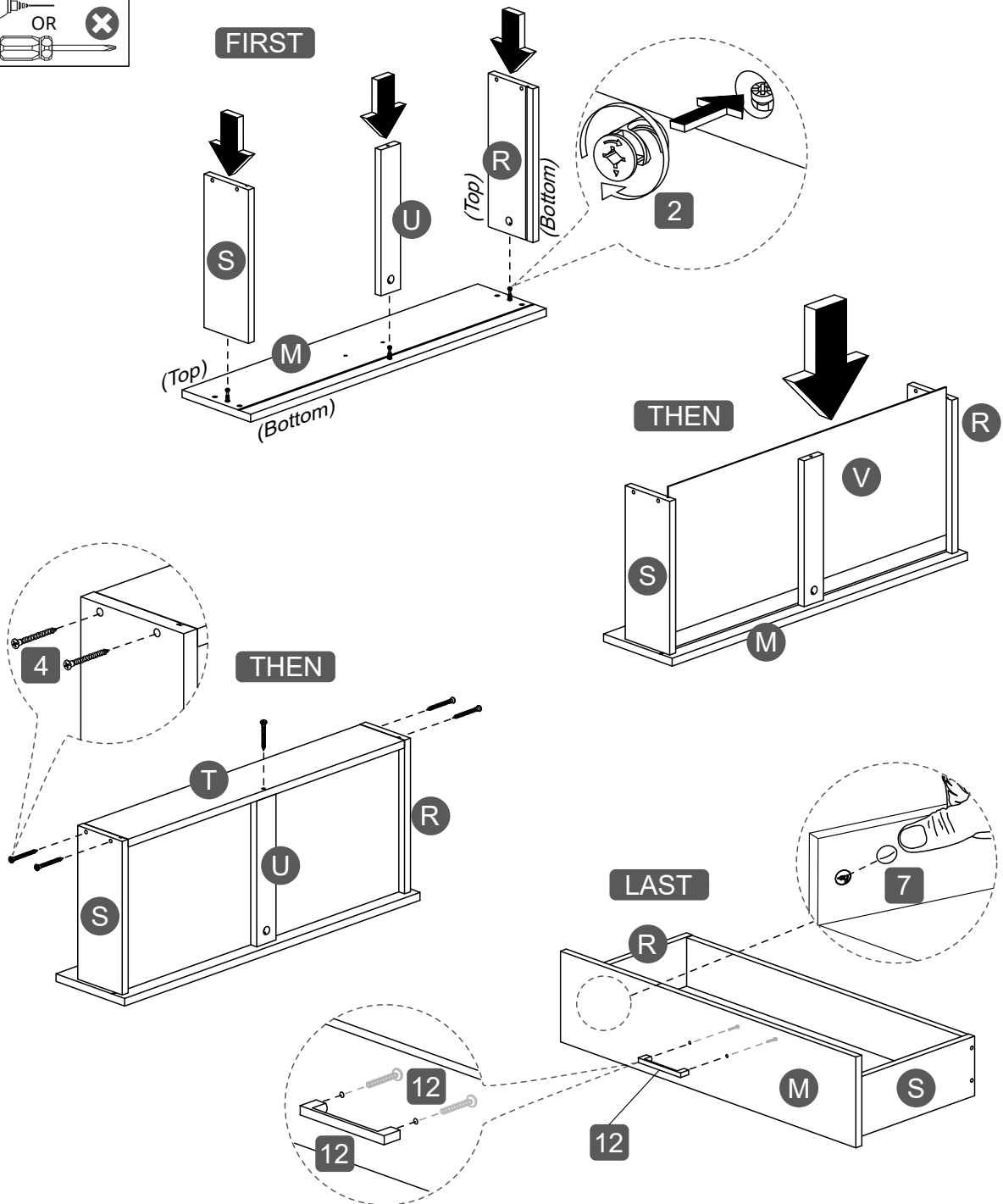

STEP 13

Hardware

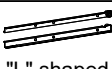
6	 M3.5x16	4 Pcs
15	 "L" shaped sliders	2 Pcs

Tools (Not included)

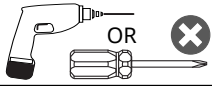

Flip the drawer upside-down and attach the "L" shaped sliders **15** to the side panels **R** and **S** respectively with screws **6**.

IMPORTANT NOTES:

- The wheels will go towards the back of the drawer.
- The sliders should not protrude below the panels, because attaching that way will raise the door 1" more and won't fit in the unit.

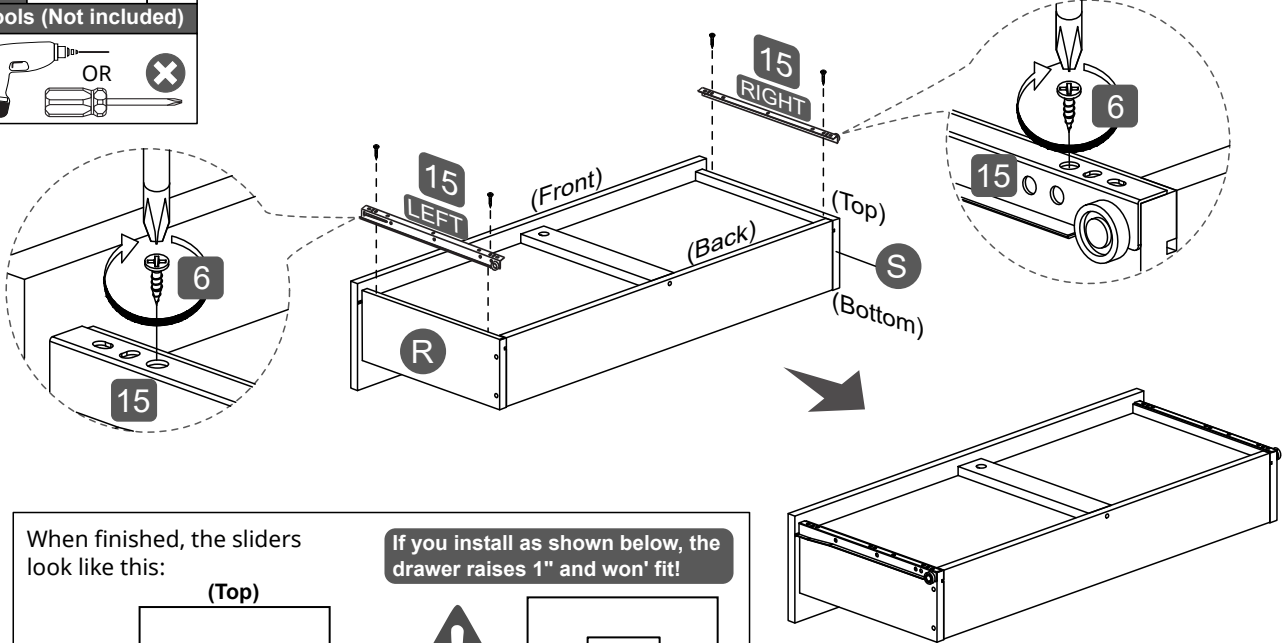

When finished, the sliders look like this:

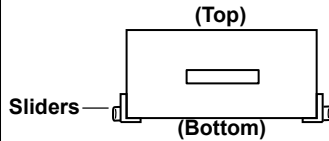

If you install as shown below, the drawer raises 1" and won't fit!

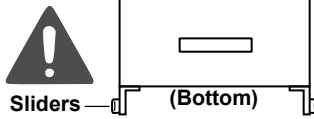

STEP 14

Hardware

8		8 Pcs
---	---	----------



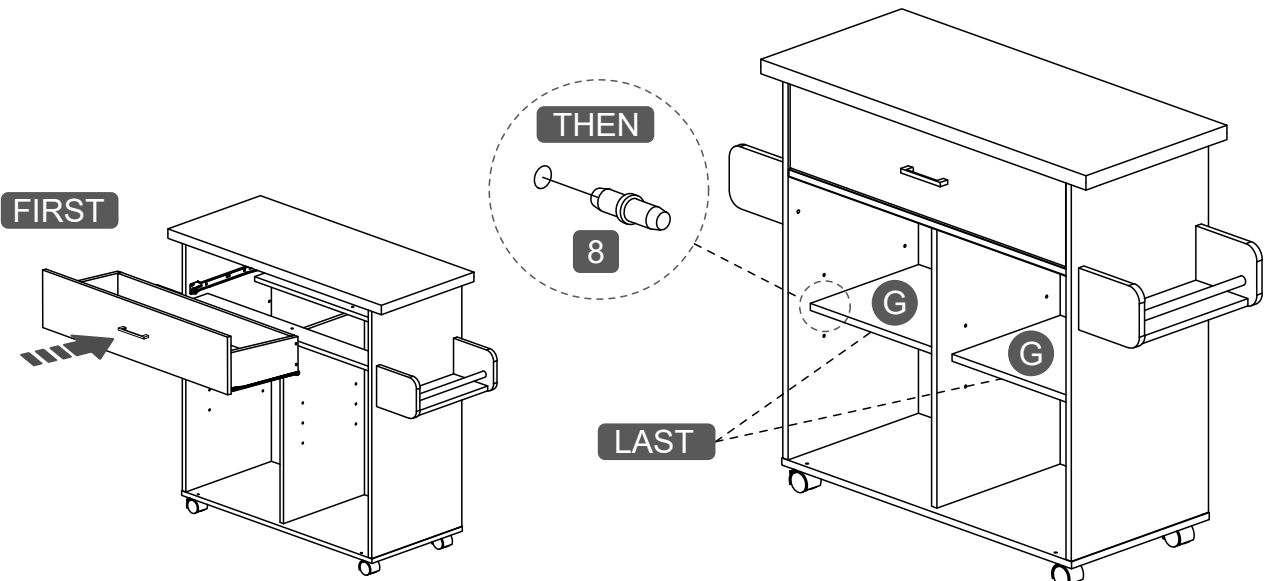

- **FIRST**, install the drawer into the unit.
- **THEN**, install the shelf supports **8** into the sets of holes inside the unit, at the height of your choice.
- **LASTLY**, place the shelves **G** over the supports **8**.



STEP 15

This step requires of 2 persons 

Hardware

6	 M3.5x16	8 Pcs
9		4 Pcs
10		2 Pcs
12		2 Sets

Tools (Not included)

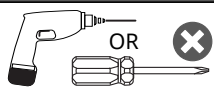

- **FIRST**, attach the flat head tapping screw from the magnet set **10** to the doors **N** and **O** as shown.
- **THEN**, attach the handles **12** to the doors with own screws **12**.
- **THEN**, attach the plastic hinges **9** to the panels **F** and **B** facing towards the side panels as shown.
- **LASTLY**, and with the help of another person, use screws **6** to attach to the hinges, the door **N** on the left side and the door **O** on the right side.

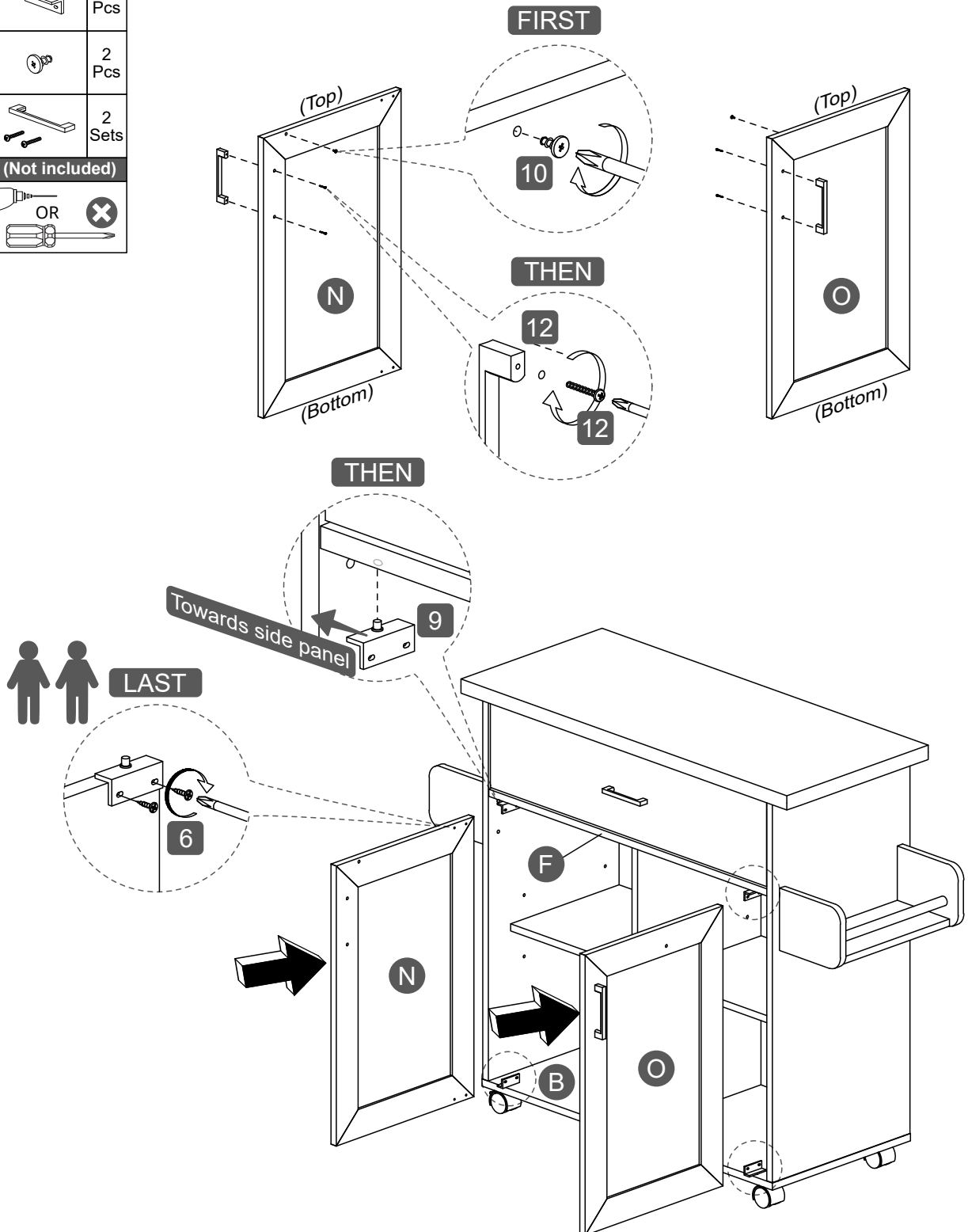

STEP 16

Hardware

5	 M3x16	12 Pcs
---	--	-----------

11		6 Pcs
----	---	----------

Tools (Not included)

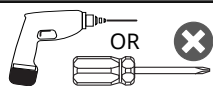

Behind the cart, insert the Z brackets **11** into the grooves of the left and right corners of the unit, and secure them with screws **5**. Please note that for the upper section (the back panel **P**) only the top corners get the brackets.

The brackets go on the corners with their thin edges inserted into the grooves.

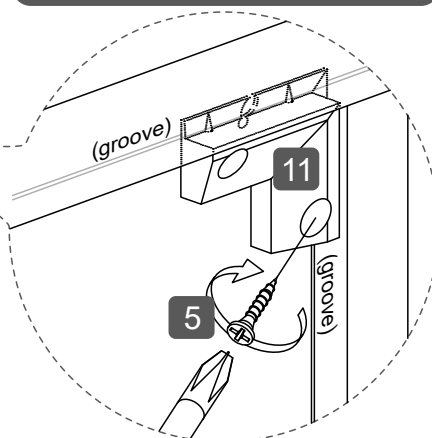
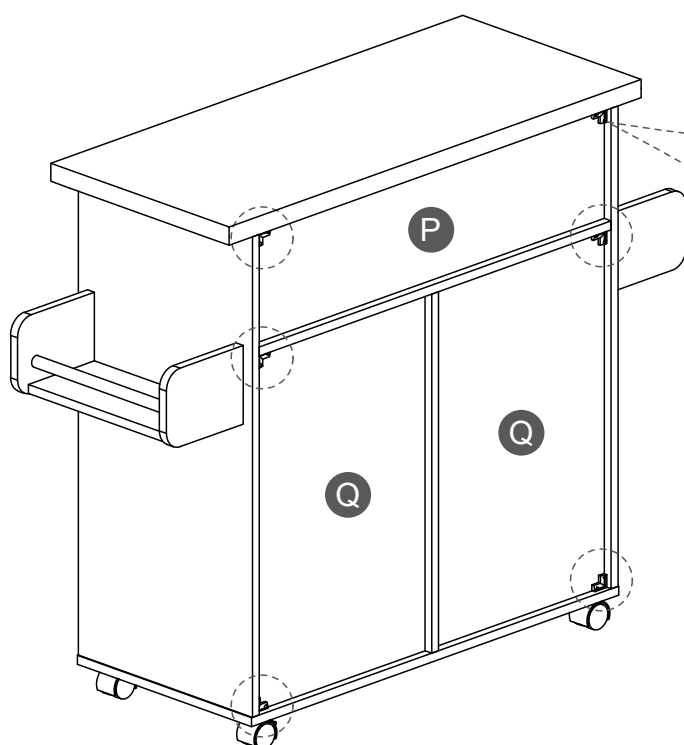

ALL DONE!

Give yourself a nice pat on the back, you did a great job!

ENJOY YOUR NEW UNIT! 

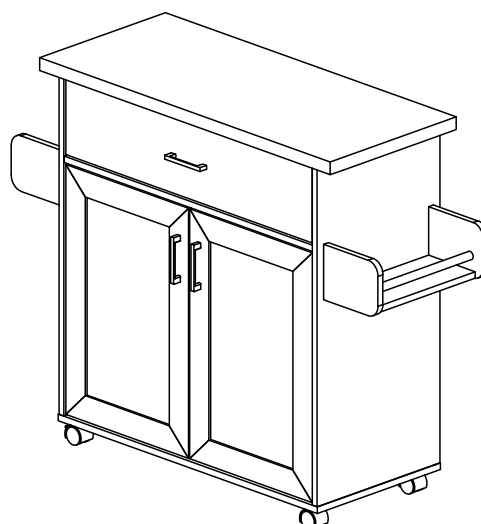

Please take your time to read all warnings and warranty information in the following pages.

WEIGHT LIMITS

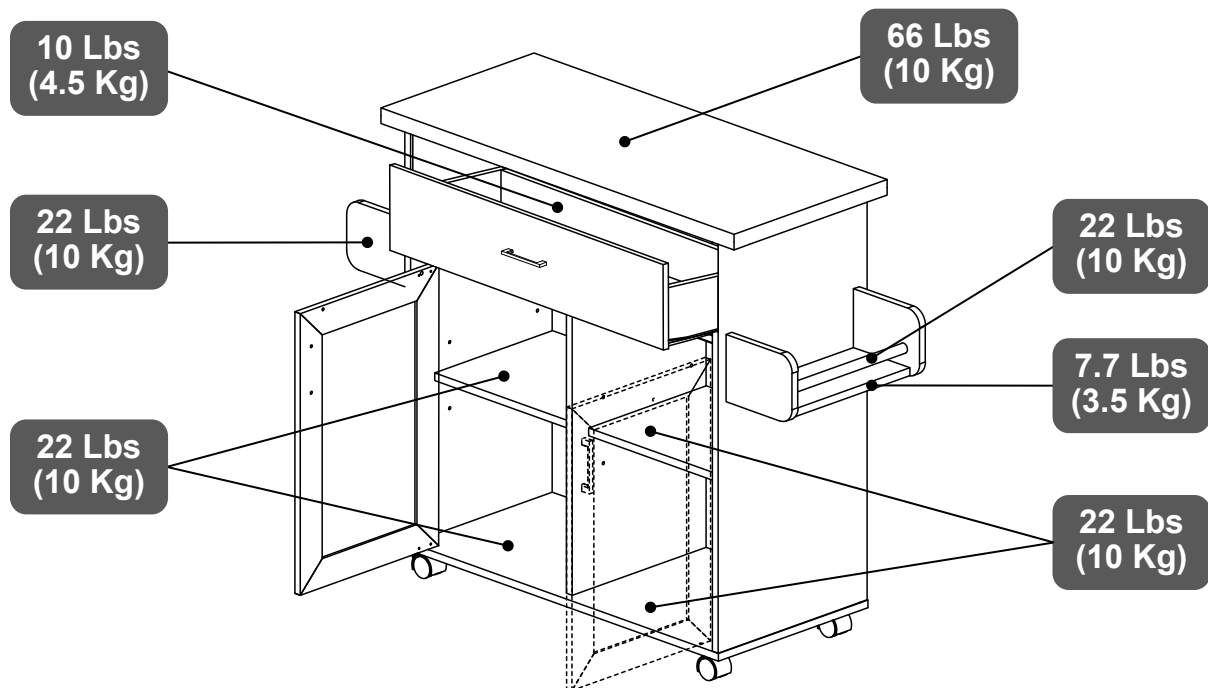

WARNINGS

- Do not exceed the indicated weight limits.
- Do not expose the surfaces to direct sunlight or to extreme environmental conditions.
- Do not use solvents or abrasive materials to clean the unit.
- Do not sit on the unit or lean against it.
- Do not allow small children to play inside the unit or climb over the unit or the side handles.
- Do not allow small children to reach inside the drawer or compartments without your supervision.
- Before moving the unit, unlock the front casters and secure or remove any object that might fall off while the unit is rolling.
- Do not use the product if screws are loose or missing, or if you notice damaged parts.
- The warranty does not extend to regular wear and tear, nor the manufacturer assumes liability for damages or consequences due to accidents, incorrect assembly, negligence, improper use, modifications, or not heeding the above warnings.

CARE AND MAINTENANCE

- Clean the surfaces preferable with a clean cloth dampened in a solution of mild soap and water, then dry with a clean towel.
- If you decide to use a cleaning agent, test first on an area hidden from view such as underneath the tabletop.
- Every 4 months, inspect the unit completely and make sure that all screws are tighten.
- When transporting the unit to places far away, protect and secure the unit to avoid damage in transit.

TECHNI HOME WARRANTY

**1-YEAR LIMITED WARRANTY**

RTA Products, LLC warrants to the Original Purchaser who acquired a new product from RTA Products or its authorized resellers that this product will be free from defects in its workmanship and materials, under normal use and service conditions, as described herein. "Defects" as used in this warranty, is defined as any imperfections that impair the use of the furniture or product. RTA Products LLC will replace any defective part, at its discretion, and without charge to the original purchaser other than the freight from the end consumer to RTA Products.

Replacement parts can only be supplied if parts are available. Items out of production may be unavailable. This warranty will be effective for the applicable time period beginning the date of purchase on your original sales receipt. RTA product's obligation under this warranty is limited to repairing or replacing products or parts as provided herein. This product has been designed for and is intended for office and home-office use only. This warranty is Original Purchaser's sole remedy for product defects, and this warranty does not extend to any product, or damage to any product, caused by or attributed to abuse or misuse, products used for commercial or rental purposes, use modifications of, or attachments to the product, and products or parts not used, maintained, or extended hereunder is in lieu of any and all other warranties, express or implied, including without limitations any implied warranty or merchantability or of fitness for a particular purpose. Please note, all desks made with PVC Laminate surface should not be exposed to direct sunlight, as it may damage the material. Damage of this nature is not covered under this warranty.

RTA Products will not be responsible for indirect, special, incidental or consequential damages. This warranty is limited to merchandise purchased in the Continental United States, excludes AK, HI and PR. Some States do not allow the exclusion or limitation of incidental or consequential damages, so the above limitations or exclusions may not apply to you. This warranty gives you specific legal rights. You may also have other rights that may vary from state to state.

To file a Claim within the 48 contiguous United States:

Email us to warranty@rtaproducts.com to explain the defect and provide your name, address, phone number, model number of our product, date and place, and proof of purchase. Please provide pictures of the damage or defect. If we determine that a replacement will remedy the situation, and in order to determine the extent or the cause of the defect, purchaser may be requested to send the part in question at purchaser's expense. Once we receive the part, we will examine it and determine whether the claim is valid (or not), and then proceed to send the replacement. We will ship the replacement at our expense.

Replacement Parts for International Customers & AK-HI-PR orders:

RTA Products will replace the part free of charge, while **the customer is responsible for shipping costs plus any International local taxes or duties.**