

# ASSEMBLY INSTRUCTIONS



MODEL RTA-8400

Thanks for purchasing one of our products.  
Please read carefully the assembly instructions before the installation.  
Please save this manual for future reference.



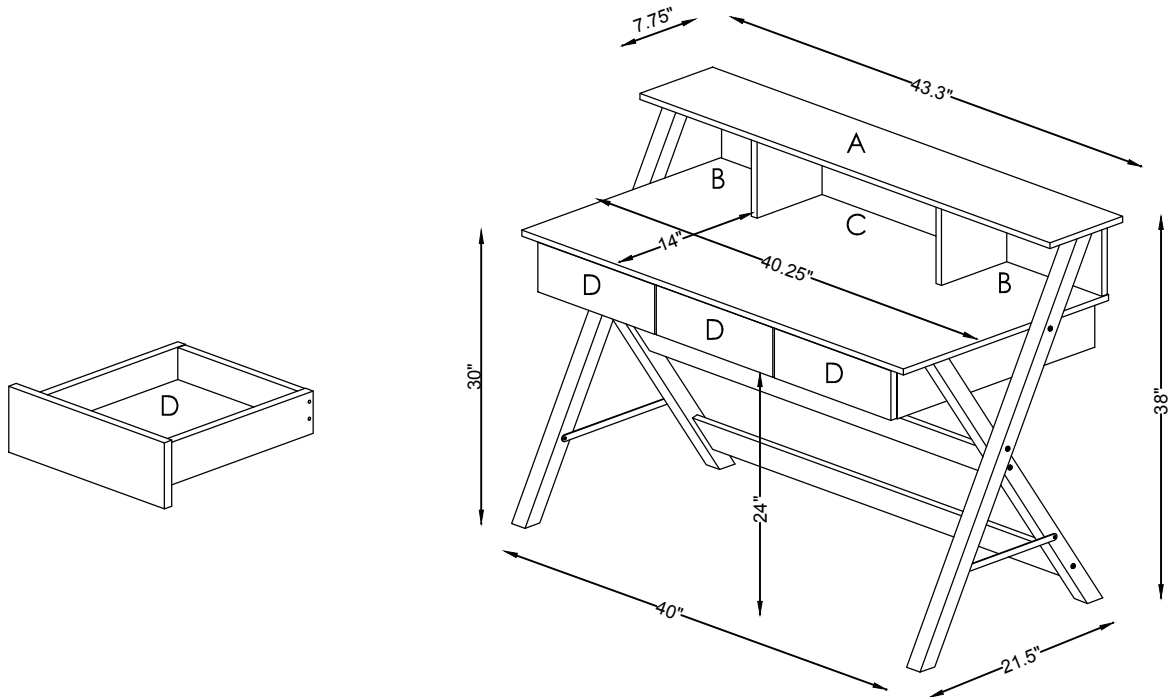

### GENERAL SPECIFICATIONS

WIDTH : 43.3"

DEPTH : 21.5"







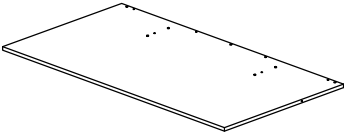
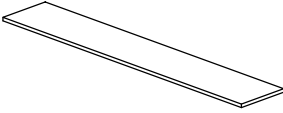
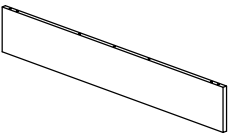
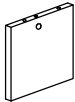
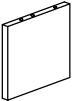
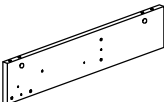
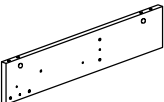

HEIGHT : 38"

PRODUCT NET WEIGHT : 54 Lbs

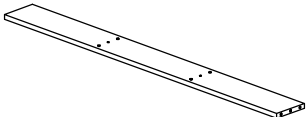
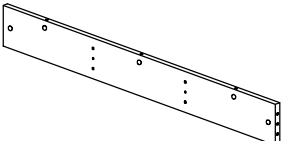
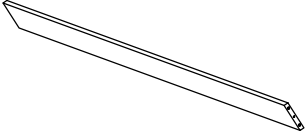

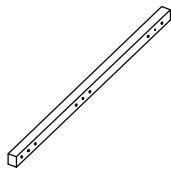

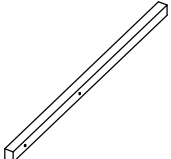
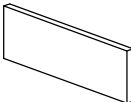
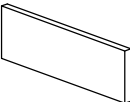
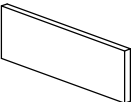
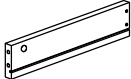
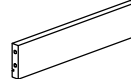

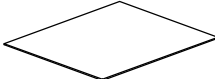

SHIPS IN 1 BOX





	INTERNAL DIMENSIONS (WxDxH)	WEIGHT LIMIT
MAIN PANEL	N/A	75 LBS
SHELF A	N/A	50 LBS
SHELF B	10" x 6.75" x 7.75"	30 LBS
SHELF C	18.75" x 6.75" x 7.75"	30 LBS
DRAWER D	9.5" x 11" x 3"	10 LBS



**•PARTS LIST**

<p><b>A</b></p>  <p>▪ Main Panel</p>	<p><b>B</b></p>  <p>▪ Top Shelf Panel</p>	<p><b>C</b></p>  <p>▪ Back Panel (upper)</p>	<p><b>D</b></p>  <p>▪ Stand Panel Left (upper)</p>	
<p><b>E</b></p>  <p>▪ Stand Panel Right (upper)</p>	<p><b>G</b></p>  <p>▪ Side Panel Left</p>	<p><b>H</b></p>  <p>▪ Side Panel Right</p>	<p><b>I</b></p>  <p>▪ Stand Panel (lower) x 2</p>	<p><b>J</b></p>  <p>▪ Cross bar (front)</p>
<p><b>K</b></p>  <p>▪ Cross bar (center)</p>	<p><b>L</b></p>  <p>▪ Cross bar (back) x 2</p>	<p><b>M</b></p>  <p>▪ Front-Left Leg</p>	<p><b>N</b></p>  <p>▪ Back-Left Leg</p>	
<p><b>O</b></p>  <p>▪ Front-Right Leg</p>	<p><b>P</b></p>  <p>▪ Back-Right Leg</p>	<p><b>Q</b></p>  <p>▪ Drawer Front Left</p>	<p><b>R</b></p>  <p>▪ Drawer Front Middle</p>	<p><b>S</b></p>  <p>▪ Drawer Front Right</p>
<p><b>T</b></p>  <p>▪ Drawer Side Left x 3</p>	<p><b>U</b></p>  <p>▪ Drawer Side Right x 3</p>	<p><b>V</b></p>  <p>▪ Drawer Back x 3</p>	<p><b>W</b></p>  <p>▪ Drawer Bottom x 3</p>	

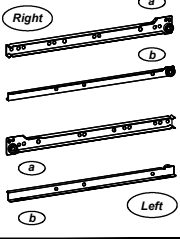
**•HARDWARE**

PART	QTY.	ITEM	
1	56Pcs	<b>Wooden Pin</b>	
2	12Pcs	<b>Screw - 5 x 8mm</b> <i>(Euro Screw)</i>	
3	16Pcs	<b>Screw - 3.5 x 16mm</b>	
4	12Pcs	<b>Screw - 4 x 38mm</b>	
5	10Pcs	<b>Screw - 5 x 38mm</b>	
6	2Pcs	<b>Screw - M6 x 40mm</b>	
7	8Pcs	<b>Screw - M7 x 60mm</b>	
8	29Sets	<b>Cam Lock &amp; Bolt Sets</b>	

PART	QTY.	ITEM	
9	4Pcs	<b>Plastic Feet</b>	
10	8Pcs	<b>Plastic Cap</b>	
11	2Pcs	<b>Plastic Cap</b>	
12	3Sets	<b>Sliders Sets</b>	
13	1Pc	<b>L Key</b>	
14	2Pcs	<b>Metal Plate</b> <i>(304x15x2mm)</i>	

 • Cam Bolt    
  • Cam Lock    
 ■ BOLT INSTALLATION AS BELOW :

---

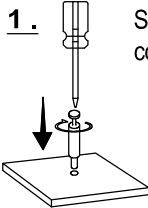
**1.**  Screw bolt into the corresponding panel.

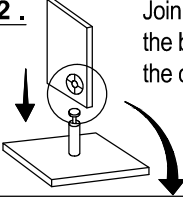
**2.**  Join the panels by inserting the bolt into the hole with the cam lock.

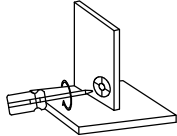
**3.**  Turn the cam lock.

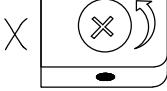
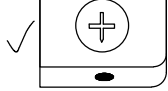
 INCORRECT: Turn cam lock
  CORRECT:

■ Before assembling panels that use the cam bolt and cam lock, make sure that the cam lock is aligned to receive the bolt.

**Attention :** Holes on panels may be hidden underneath PVC laminate!!!  
 Do not tighten the screws until all of them are in the right position.

## GENERAL ASSEMBLY TIPS AND TROUBLESHOOTING DURING ASSEMBLY:

- \* Before you start assembling, make sure you have all the parts and necessary hardware by doing a quick inventory.
- \* Follow the assembly instructions step by step, and do not skip any unless advised to do so by RTA PRODUCTS' Customer Service.
- \* On each step, and to avoid misalignments, always leave screws loose, and do not tighten them until all are in place.
- \* In wood panels, the laminate might be covering the holes.  
If there are no visible holes: Pass the tip of your finger around the area where the hole should be, and press against the surface to feel the indentation.  
If the hole looks too small for the screw or bolt: carefully perforate the laminate with the tip of a pen.

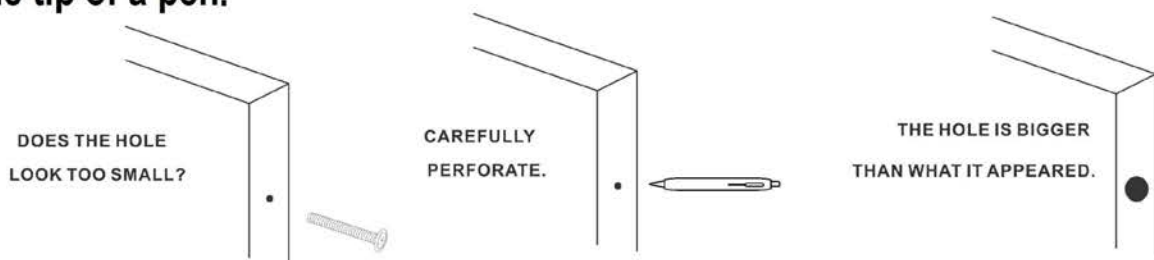

- \* In wood panels, some might have inserts that look like screws. Those inserts are either nuts or cam locks. Make sure they are aligned to receive the screws or bolts.

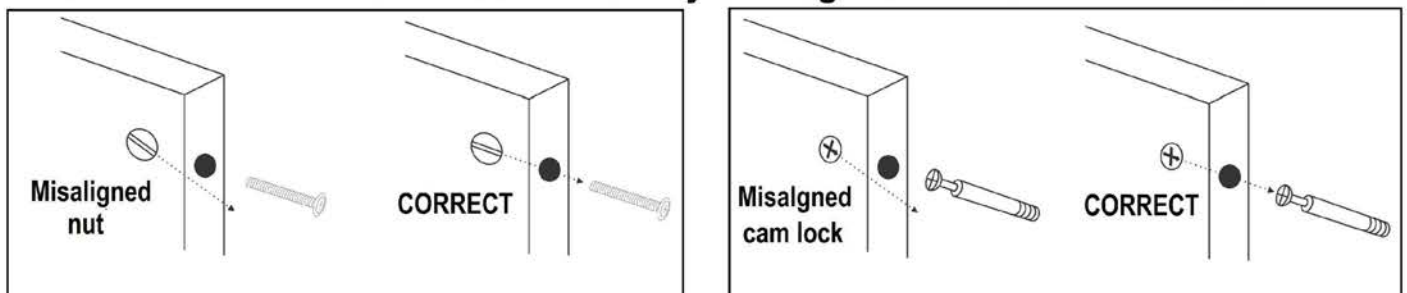

- \* Make sure to use the correct screws or bolts, and do not overtighten them. Using wrong screws or overtightening them might cause damage to the parts, and such damage is not covered by the product's warranty.

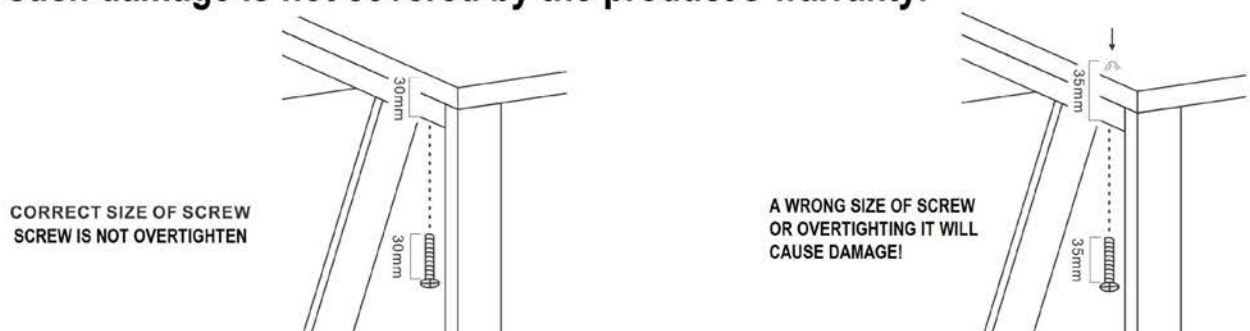

1

1 x56

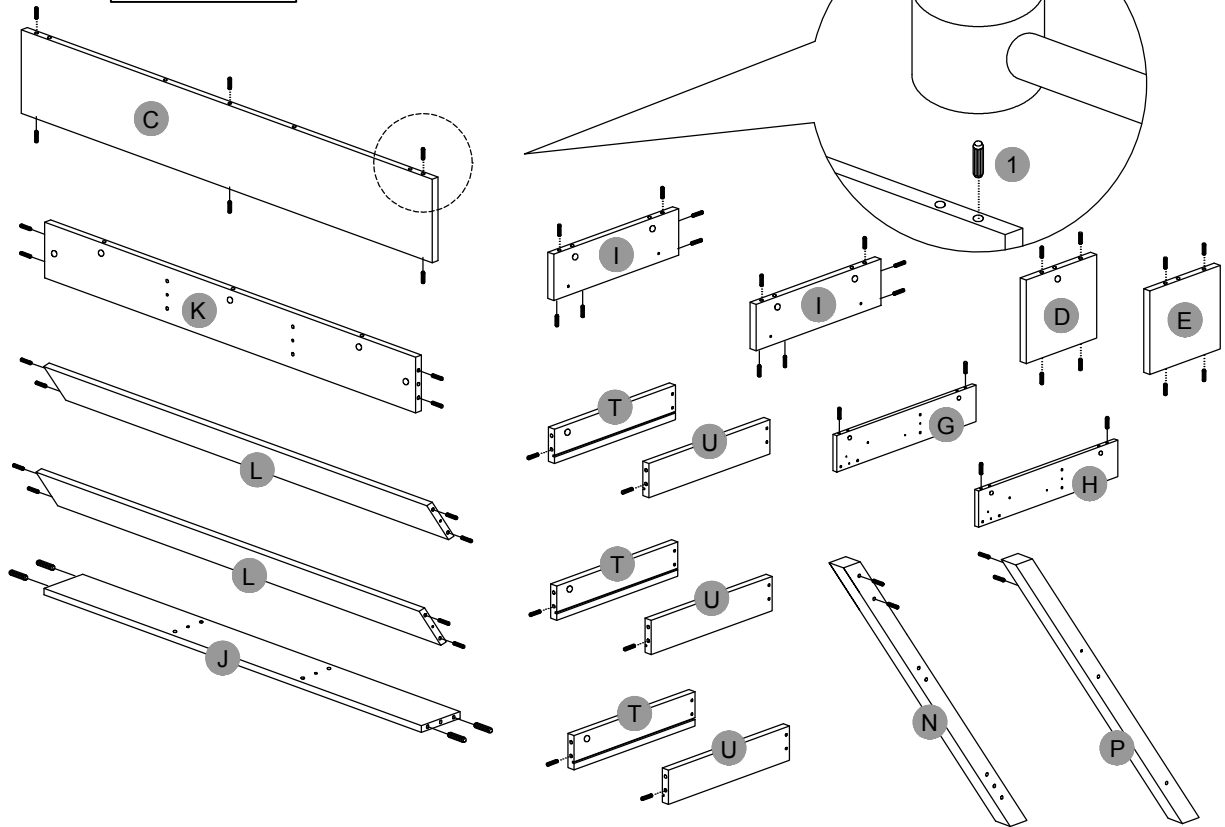

Insert the wooden pins (1) into the corresponding holes on panels (C), (D), (E), (G), (H), (I), (J), (K), (L), (N), (P), (T) and (U) as shown. Please make sure to insert them in the correct holes as some holes are intended for different hardware in subsequent steps.

2

8 x29

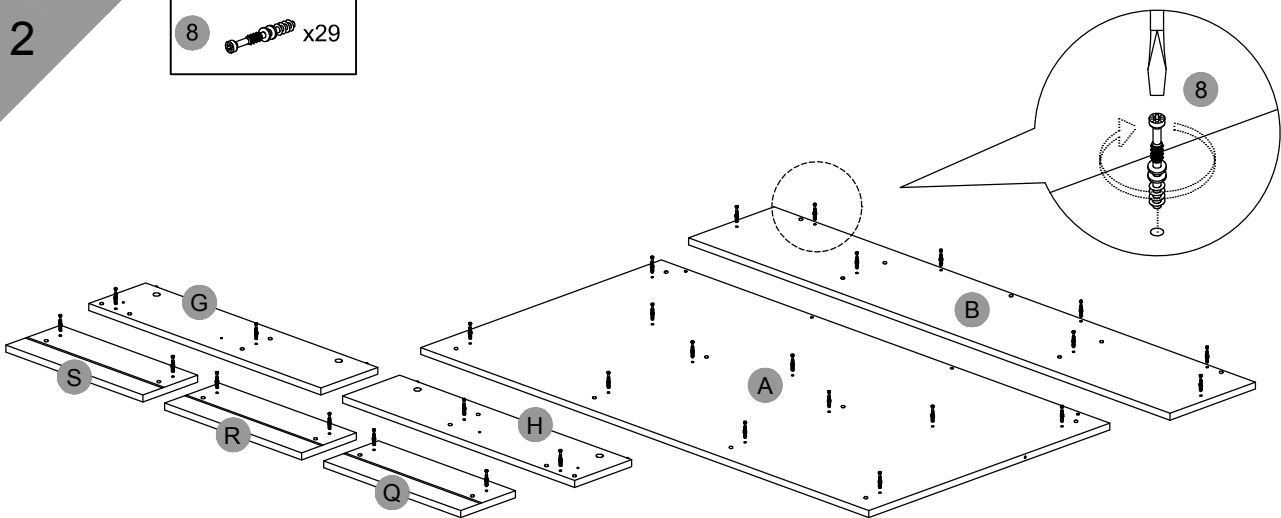

Attach the cam bolts (8) to the corresponding holes on panels (A), (B), (G), (H), (Q), (R) and (S) as shown. Please make sure to attach them to the correct holes as some holes are intended for different hardware in subsequent steps.

3

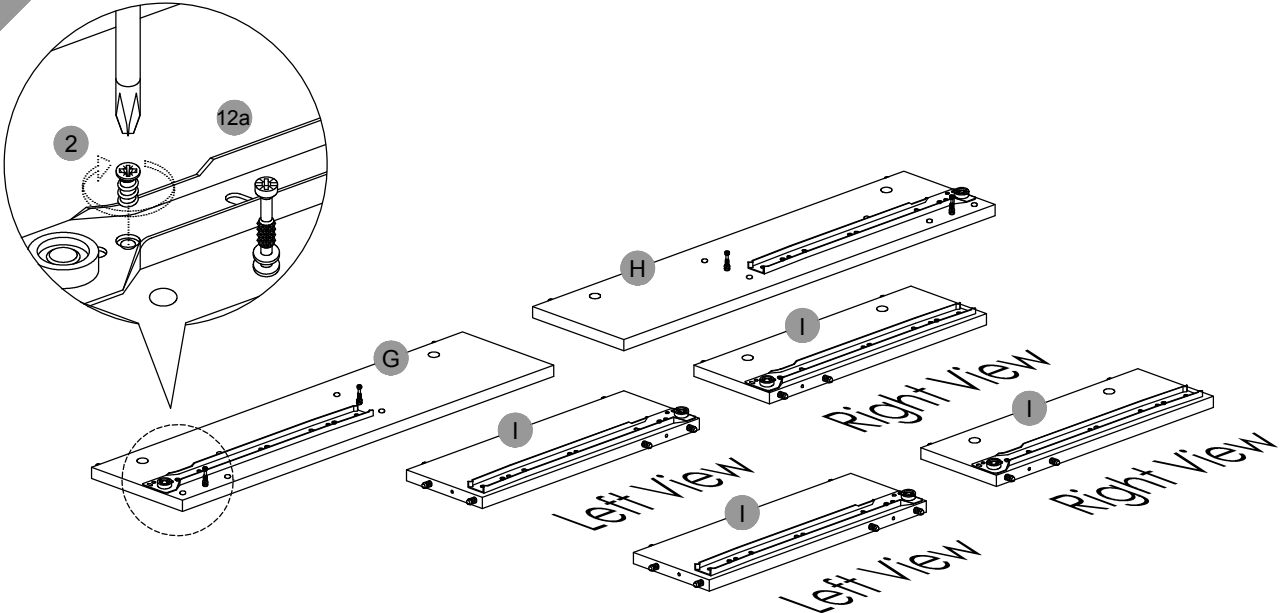

Assemble the FLAT sliders (12) to the panels (G), (H) and (I) using screws (2) as shown. For better orientation and correct assembly, place the panels as shown and screw the sliders first at the front then at the back. On panels (I) the sliders attach to both sides. NOTE: The "L" shaped sliders are used until step 14.

4

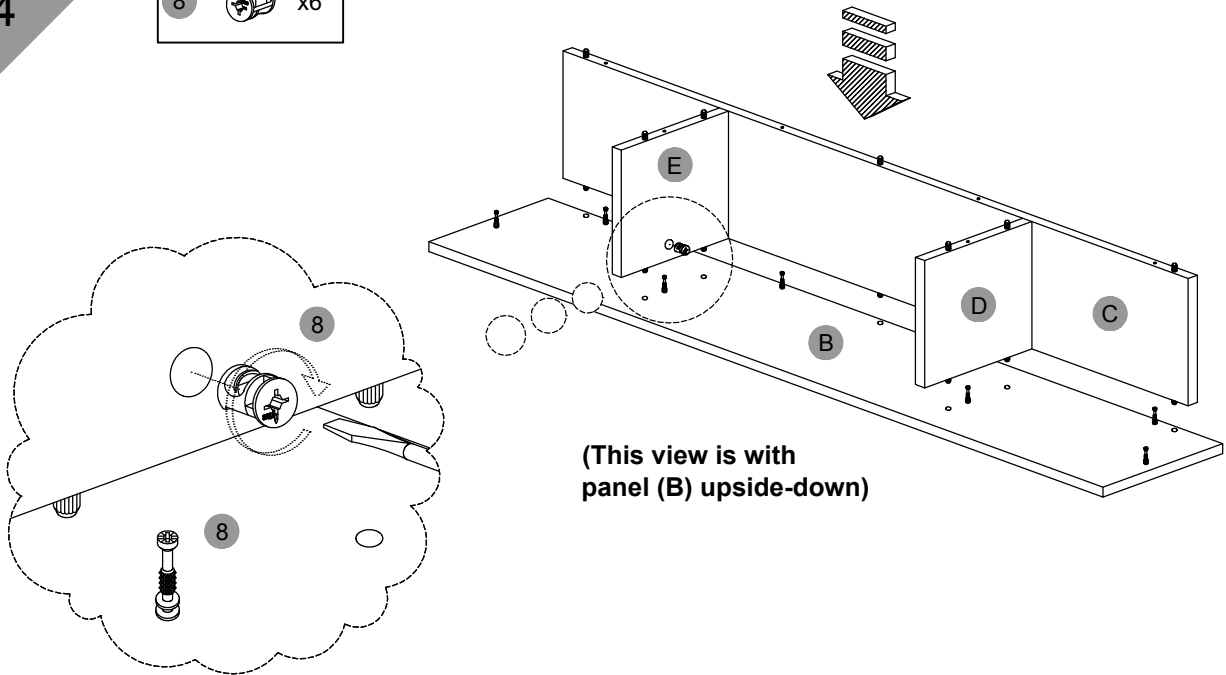

Insert and align the cam locks (8) into panels (C), (D) and (E), then assemble these panels to the Top Shelf Panel (B) as illustrated and as explained in page 4 of this manual.

5

5  x6

(This view is from underneath the Main Panel (A) with its front facing UP, and panels (B/C/E/D) behind it)

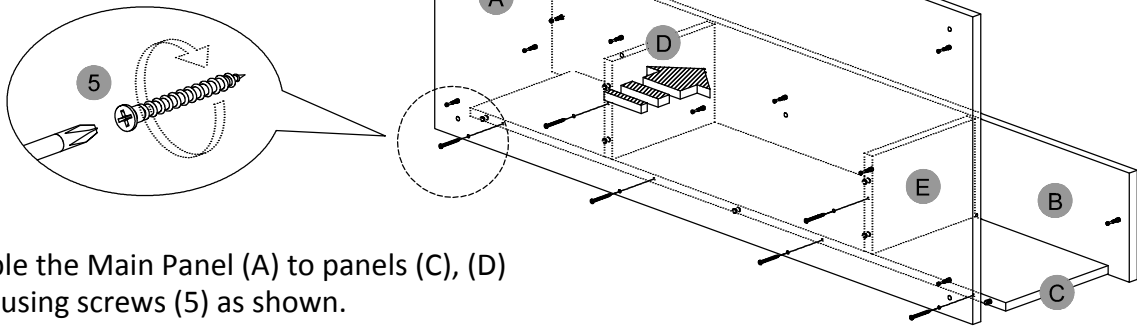

Assemble the Main Panel (A) to panels (C), (D) and (E) using screws (5) as shown.

6

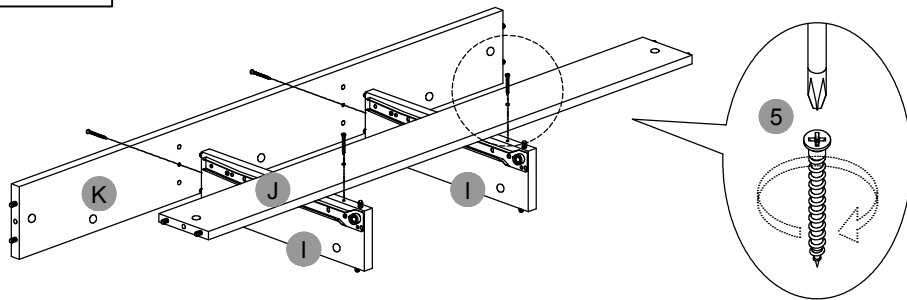
5  x4

Assemble the panels (J) and (K) to panels (I) using screws (5) as shown.

7

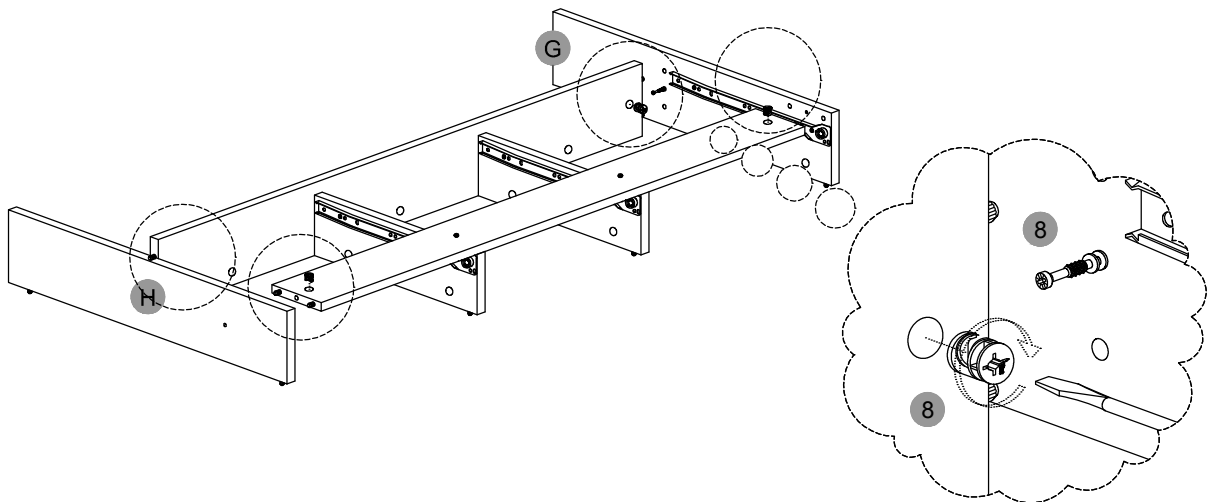
8  x4

Insert and align the cam locks (8) into panels (J) and (K), then assemble the panels (G) and (H) on the sides as illustrated and as explained in page 4.

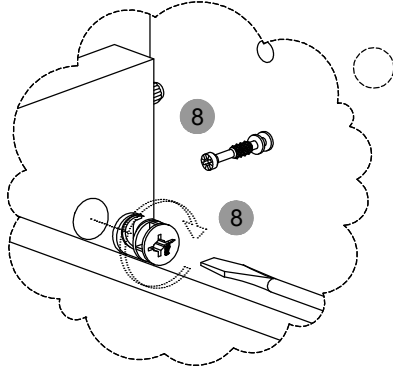

8

8  x11

(This view is from underneath the unit with its front facing UP)

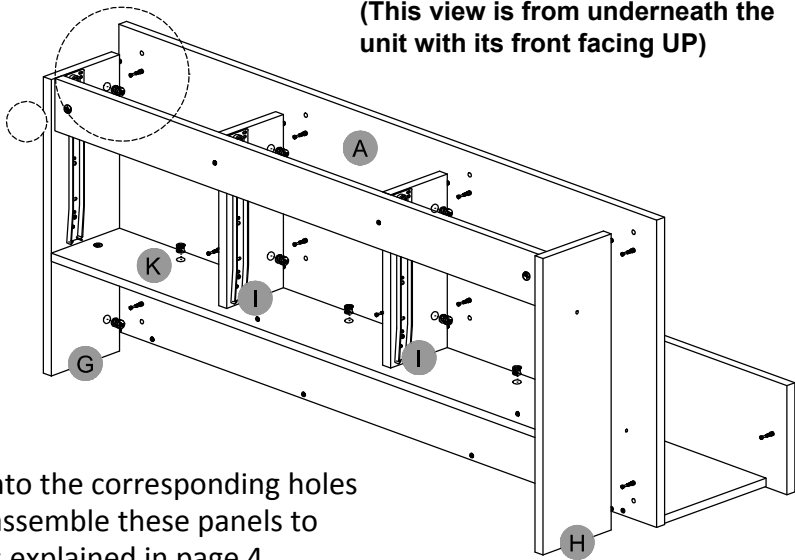

Insert and align the cam locks (8) into the corresponding holes on panels (G), (H), (I) and (K), and assemble these panels to Main Panel (A) as illustrated and as explained in page 4.

9

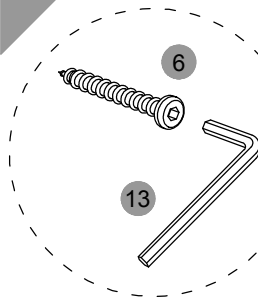
6  x27  x413  x1

(This view is from underneath the unit with its front facing UP)

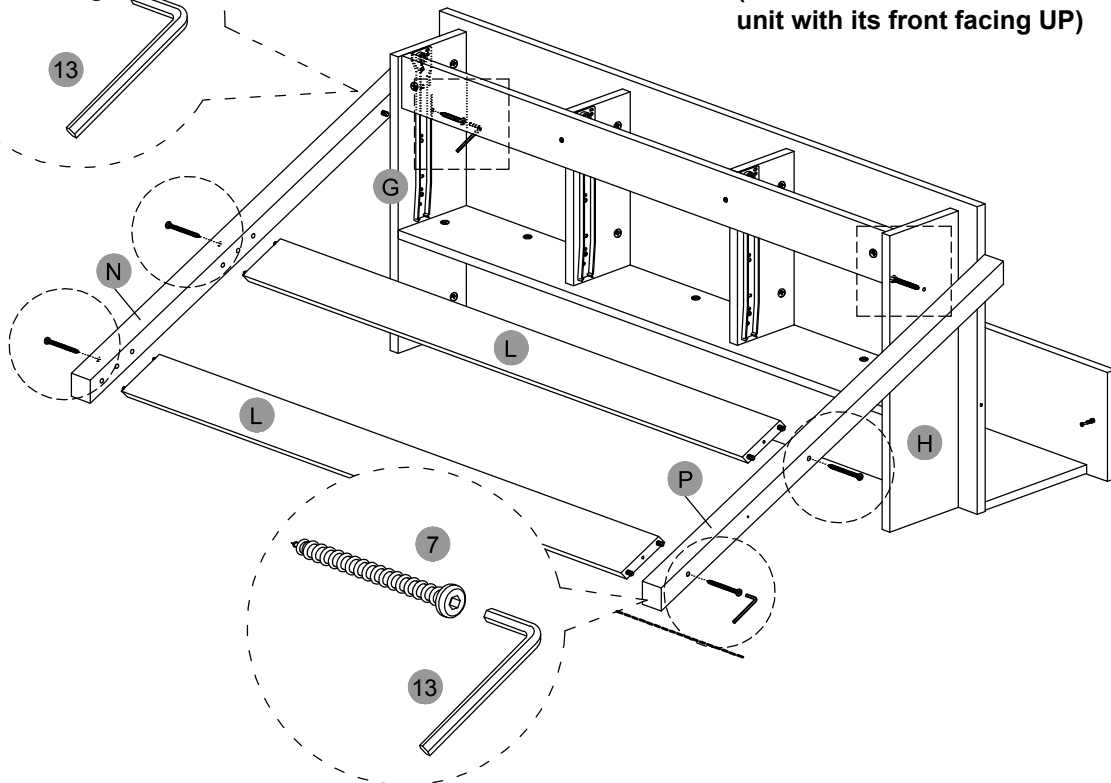

First assemble very loose the Back Right Leg (P) to panel (H) and the Back Left Leg (N) to panel (G) using screw (6) as shown (screws go from inside of unit). Then assemble very loose the Panels (L) to legs (P) and (N) using screws (7) as shown. Finally, tighten all the screws.

10

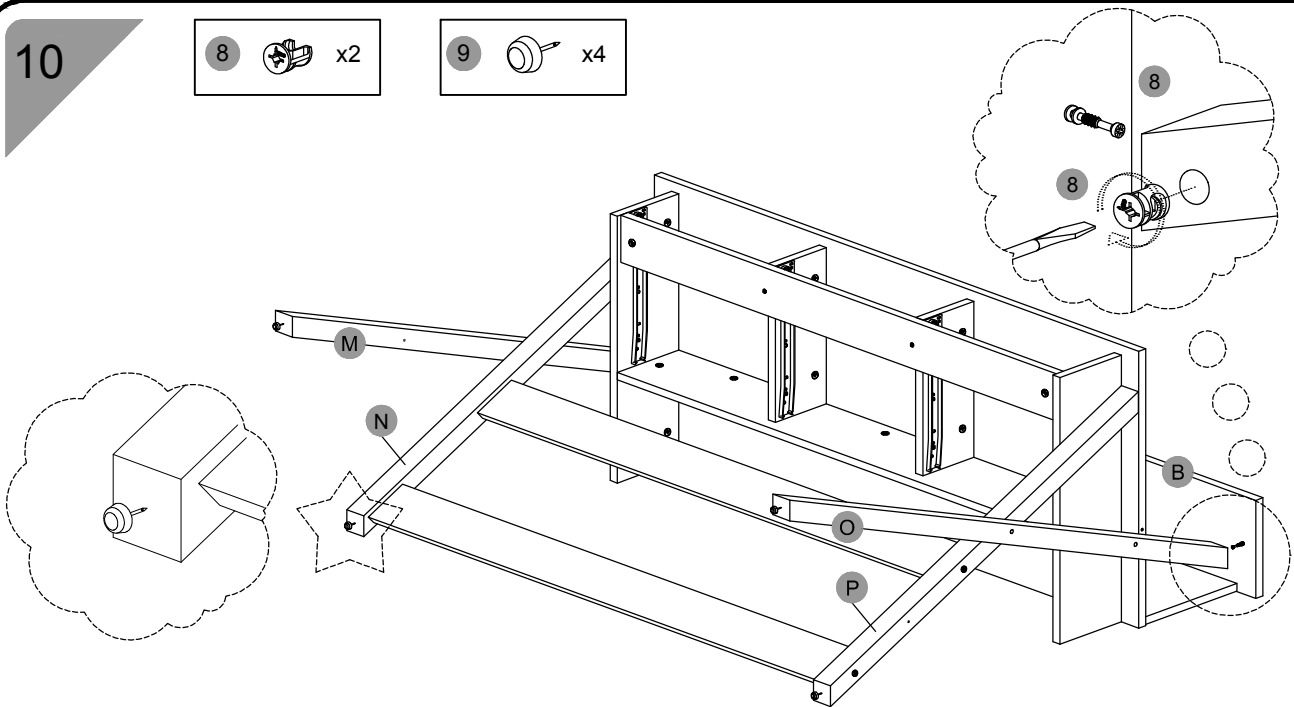
8  x29  x4

Using cam locks (8), assemble the Front-Left Leg (M) to the Top Shelf Panel (B) ON THE LEFT SIDE, and the Front-Right Leg (O) ON THE RIGHT SIDE as illustrated and as explained in page 4. Then attach the Plastic Feet (9) to the bottom of the legs as shown.

11

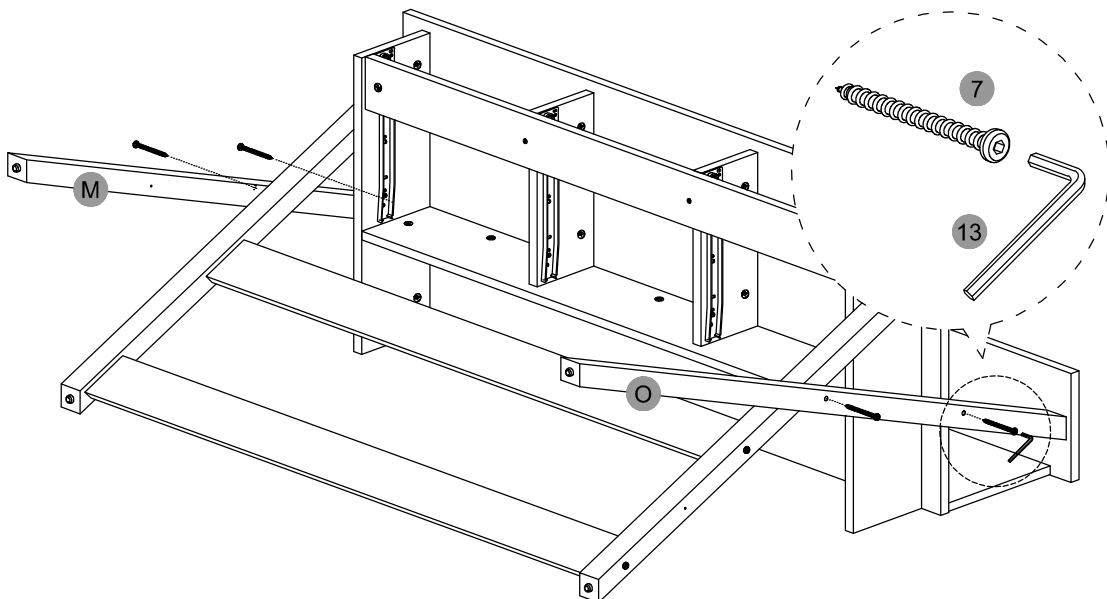
7  x413  x1

Secure both legs (M) and (O) to the legs (N) and (P) and to the Main Panel (A) using screws (7) as shown.

12

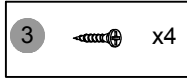

(You can now place the unit in its upright position)

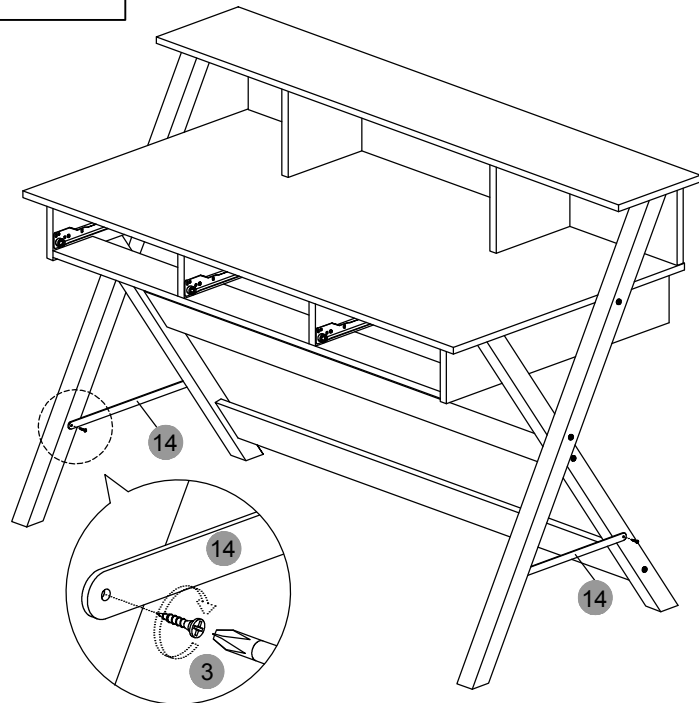

Assemble the Metal Plates (14) to the legs on both sides of the unit using screws (3) as shown.  
NOTE: On the back legs screw from the OUTSIDE, on the front legs screw from the INSIDE.

13

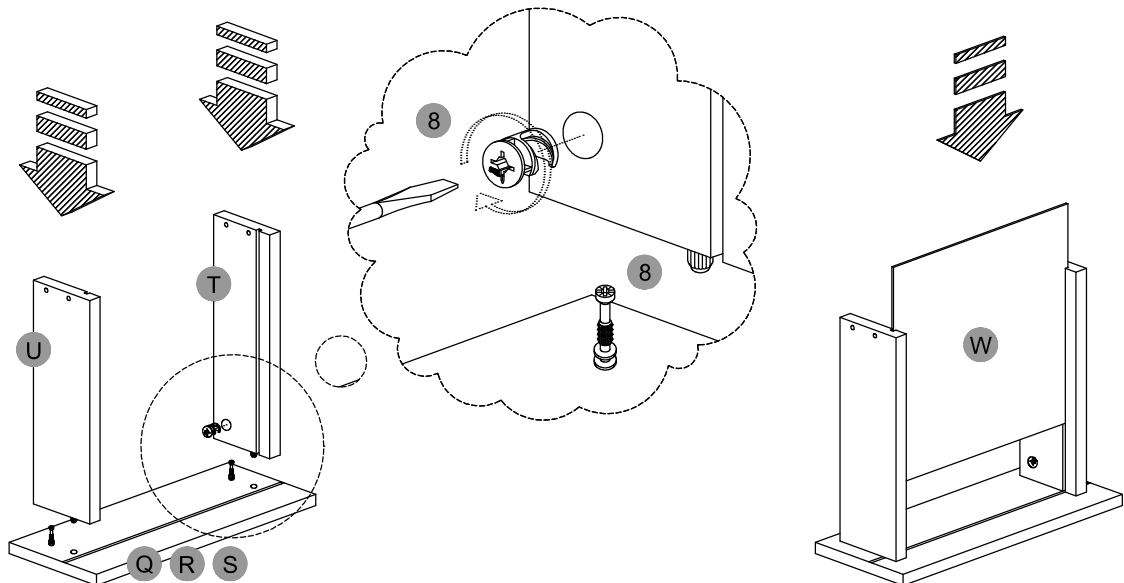

First assemble each of the drawer front panels (Q), (R) and (S) to the drawer side panels (T) and (U) using cam locks (8) as shown and explained in page 4. Then insert the bottom panel (W) into each of the 3 drawers as shown.

14

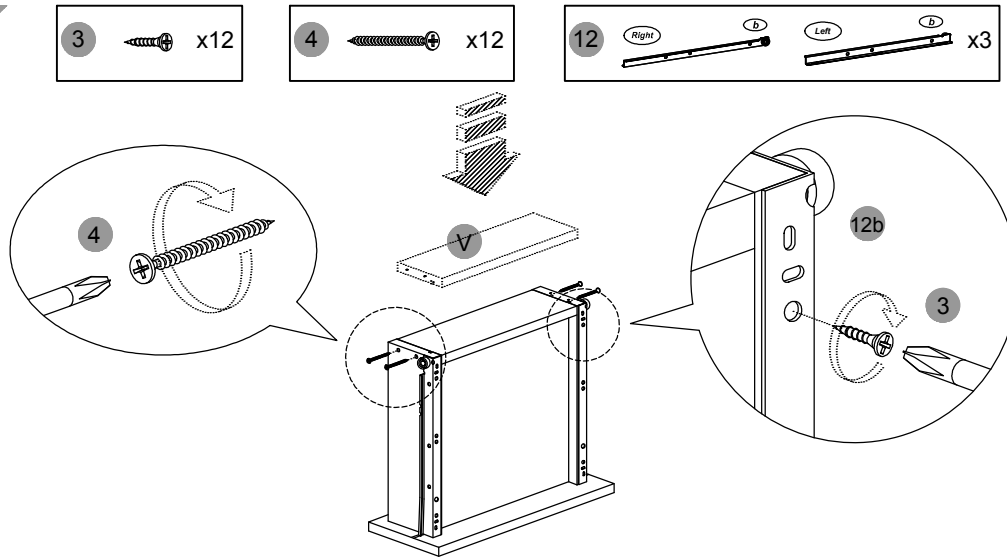

First assemble the drawer back panel (V) to each of the 3 drawers using screws (4) as shown. Then assemble the “L” shaped sliders (12) to the bottom of each of the drawers using screws (3). NOTE: On the drawers, the wheels go towards the back of the drawer, and the slider must not protrude from the bottom of the drawer, otherwise the drawer will raise about half inch more and won't fit in the unit.

15

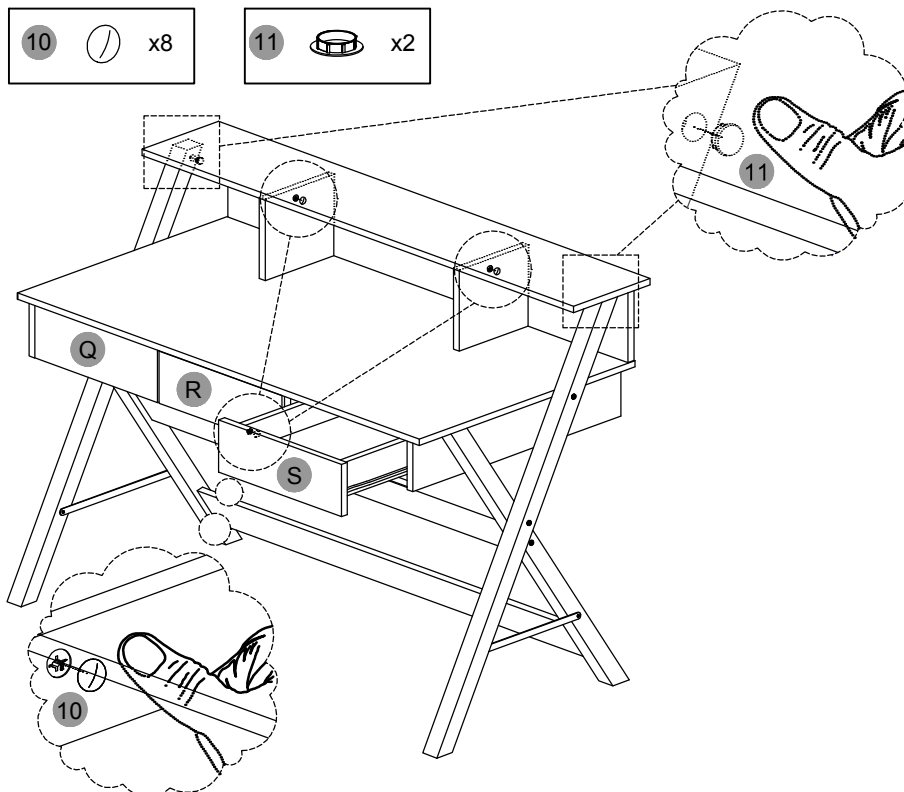

First insert the 3 drawers IN THE EXACT SAME ORDER SHOWN: (Q) on the LEFT, (R) on the CENTER, and (S) on the RIGHT, otherwise the drawers will overlap each other. Then apply the screw covers (10) to the drawers and the panels (D) and (E), and the cover (11) to legs (M) and (O).

## **CARE AND MAINTENANCE**

**PLEASE READ THOROUGHLY**

- Do not expose the surfaces to direct sunlight or to extreme environmental conditions. Damages caused by this kind of exposure is not covered by the product's warranty.
- Clean the surfaces preferable with a soft cloth damped with a solution of a mild soap and water, then dry with a clean towel.
- Do not use solvents or abrasive materials to clean any part of the unit.
- Do not allow children to play over or under the unit.
- Do not let children operate moving/mechanical parts or reach inside any of the compartments without your supervision.
- Before moving or transporting the unit:
  - a) Remove all objects from the tabletop, shelves, drawers or compartments that are heavy or might fall off.
  - b) If the unit is on wheels, make sure that they are unlocked.
  - c) If the unit is not on wheels, it must be handled by at least 2 persons. Use both of your hands and bend your legs, not your backs.
- In case of glass breakage (items with glass tops or parts) do not handle the broken glass with your bare hands, and notify the manufacturer, vendor or distributor immediately.