

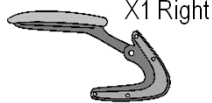







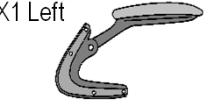

## ASSEMBLY INSTRUCTIONS FOR CHAIR MODEL RTA-8070

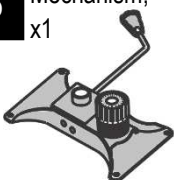
### PARTS LIST

**ATTENTION:** Before you begin the assembly, make sure that all parts are included in good condition.

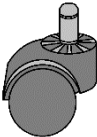
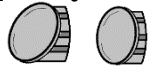
<p><b>A</b> Backrest, x1</p> 	<p><b>G</b> Armrest</p> <p>NOTE: When you are seated on the chair, not looking at it.</p> <p>X1 Right</p> 
<p><b>B</b> Seat, x1</p> 	<p>X1 Left</p> 
<p><b>C</b> Star Base, x1</p> 	<p><b>H</b> M6x25mm, x4 (Armrest to Backrest)</p> 
<p><b>D</b> Mechanism, x1</p> 	<p><b>I</b> M6x20mm, x4 (Mechanism)</p> 
<p><b>E</b> Hydraulic Gas Lift, x1</p> 	<p><b>J</b> M6x40mm, x4 Washers, x4 (Armrests to Seat)</p> 
<p><b>F</b> Caster, x5</p> 	<p><b>K</b> Hole Covers X2 Long X2 Short (Armrests)</p> 
	<p><b>L</b> Allen Wrench, x1</p> 

### ATTENTION:

- ⚠ Follow the instructions step by step.
- ⚠ To avoid misalignments, leave the screws loose and do not tighten them until all are in their respective places.
- ⚠ Do not overtighten or force the screws as they could break, strip, or damage the threads of the holes.
- ⚠ Using the wrong size of screws on a part could result in damage to the screw or the part.

- 1** Insert the casters (F) into the legs of the base (C) using pressure, then place the gas lift (E) in the middle of the base as shown.

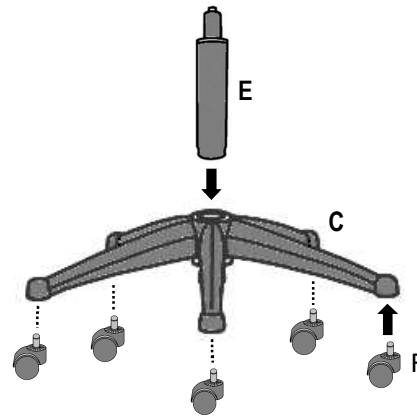

- 2** Assemble the armrests (G) to the backrest (A) on their respective sides using screws (H), but leave the screws very loose to allow flexibility on the next step.

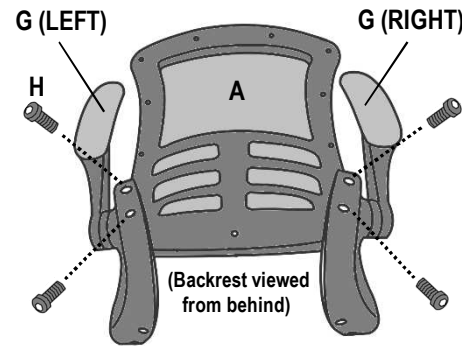

- 3** Assemble the armrests (G) to the seat (B) using screws and washers (J) as shown and tighten them.

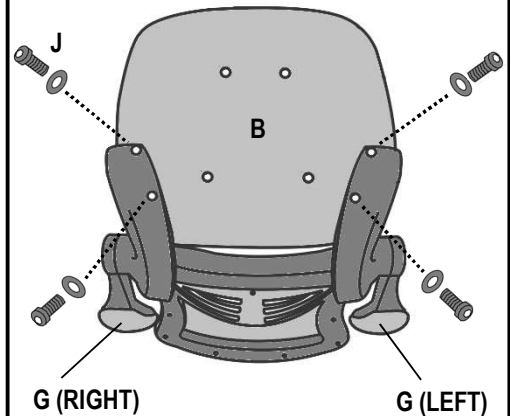

- 4** Using screws (I), assemble the mechanism (D) with its handle facing to your left and its knob towards the front of the chair as shown.

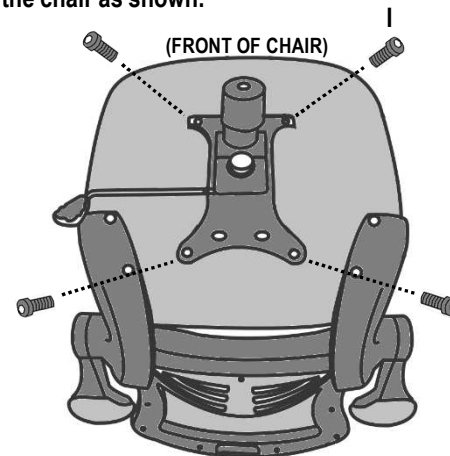

- 5** Proceed to tighten the screws (H) and then cover the top holes with the long covers (K) and the bottom holes with the short ones.

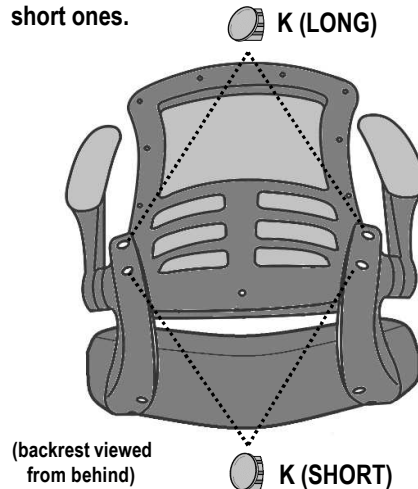

- 6** Place the seat over the base making sure that the tip of the gas lift enters in the hole of the mechanism.



Tighten well all the screws before you sit on the chair for the first time.

### CHAIR'S FUNCTIONS:

- (1) To raise or lower the chair's height, pull UP the lever that is under the seat. The chair goes down while sitting on it, or up if you lift your body.
- (2) To make the chair tilt, pull the same lever OUT horizontally to unlock this function, and IN to lock again.
- (3) To adjust the tension for the tilting function, turn the mechanism's knob in either direction to apply more or less tension.
- (4) You can flip UP the armrests to use as an armless chair.

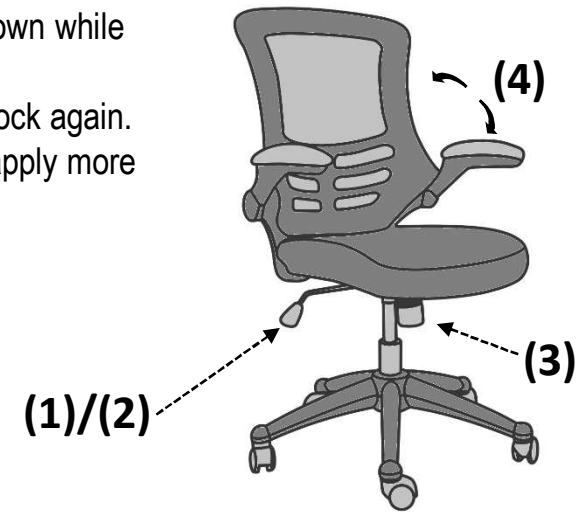

### WARNINGS:

- Do not stand up on the chair or use it as ladder.
- Use the chair to seat only one person at a time.
- Do not use the chair if parts are damaged or if screws are loose or missing.
- Do not seat near the edge of the seat and always sit properly on the chair to avoid going beyond your balance point and fall off the chair.
- The chair is intended for teenagers and adults. If small children are using the chair, please keep close observation on them.
- Do not allow small children to play with the chair.
- Not paying attention to these warnings could result in severe injuries.

### CARE AND MAINTENANCE:

- To clean the chair it is recommended to use a soft cloth lightly dampened in a solution of smooth soap and water, then dry with a clean towel.
- Do not use solvents or abrasive materials to clean any part of the chair.
- Before applying a cleaning agent, test on a small hidden area of the chair, like underneath the seat.
- Do not expose the product to direct sunlight or to extreme environmental conditions.
- Every 4 months, inspect the chair completely and make sure that all screws are tighten.