

MODEL RTA-4820D

ASSEMBLY INSTRUCTIONS

Thank you for purchasing one of our products.
Please read carefully the assembly instructions before the installation.
Do not discard this manual or any of the packaging material until the unit
has been completely assembled.

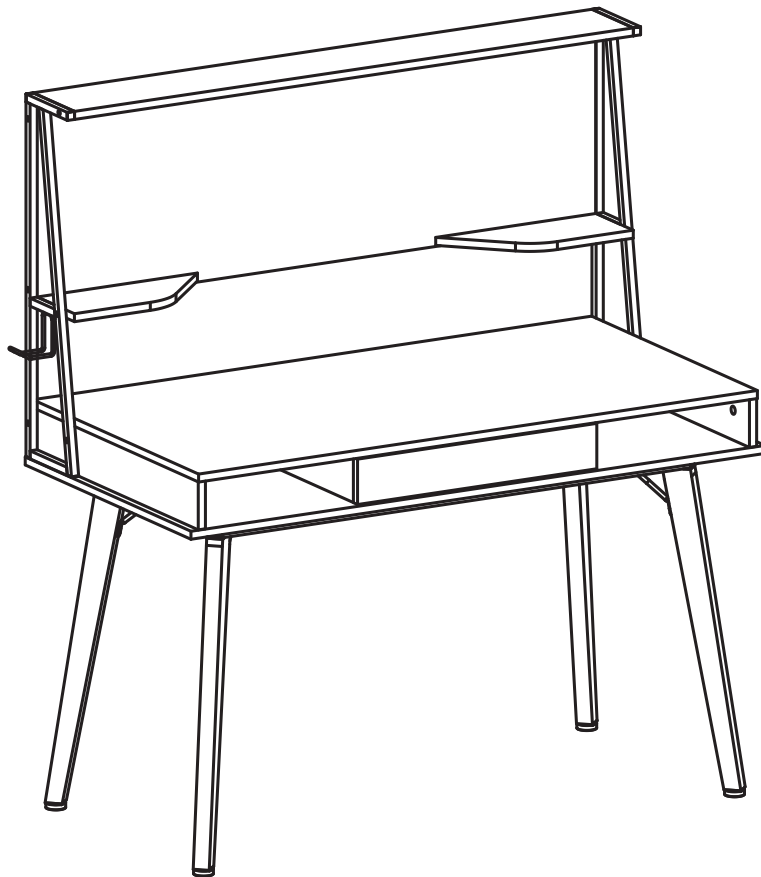

By









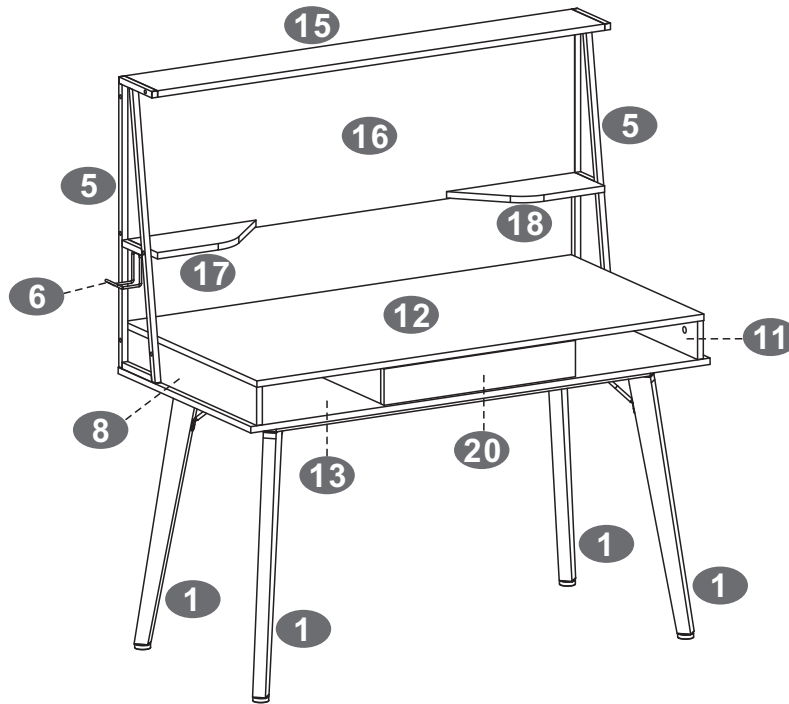

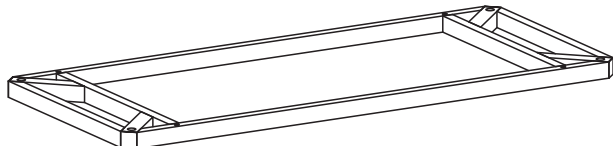



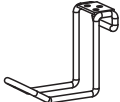

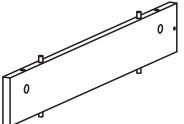
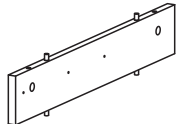
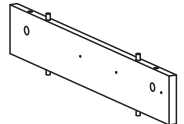
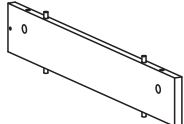

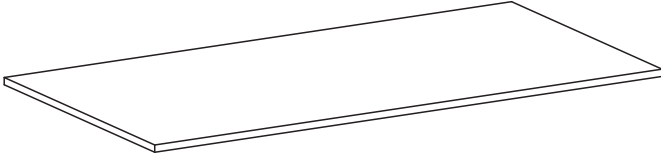
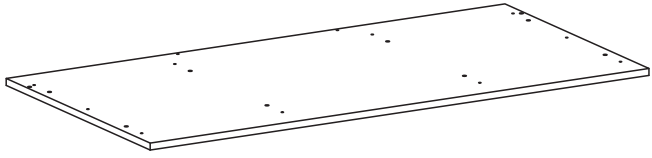
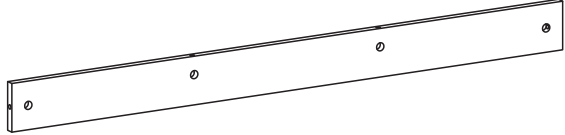
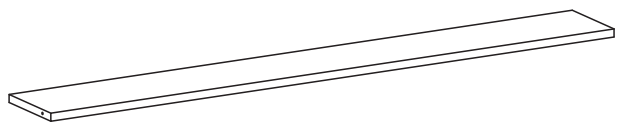
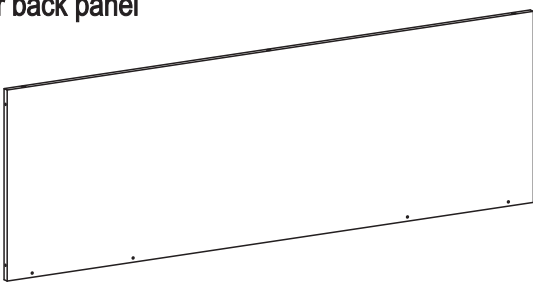
■ PARTS LIST

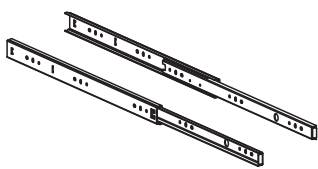
Parts Layout
(for reference):

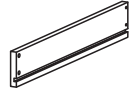

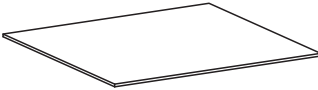
<p>Legs</p>  <p>1</p> <p>X4</p>	<p>Main structure</p>  <p>2</p> <p>X1</p>	<p>Studs</p>  <p>3</p> <p>X4</p>	
<p>Leg supports</p>  <p>4</p> <p>X4</p>	<p>Side structures</p>  <p>5</p> <p>X2</p>	<p>Accessory hanger</p>  <p>6</p> <p>X1</p>	<p>Drawer connectors</p>  <p>7</p> <p>X2</p>
<p>Left external side panel</p>  <p>8</p> <p>X1</p>	<p>Left internal side panel</p>  <p>9</p> <p>X1</p>	<p>Right internal side panel</p>  <p>10</p> <p>X1</p>	<p>Right external side panel</p>  <p>11</p> <p>X1</p>

<p>Main panel 12</p>  <p>X1</p>	<p>Bottom panel 13</p>  <p>X1</p>		
<p>Lower back panel 14</p>  <p>X1</p>	<p>Top shelf panel 15</p>  <p>X1</p>		
<p>Upper back panel 16</p>  <p>X1</p>	<p>Left middle shelf 17</p>  <p>X1</p>	<p>Right middle shelf 18</p>  <p>X1</p>	
<p>Drawer sliders 19</p>  <p>X1</p> <p>Note: Both are the same</p>	<p>Drawer front panel 20</p>  <p>X1</p>	<p>Drawer left panel 21</p>  <p>X1</p>	<p>Drawer Right panel 22</p>  <p>X1</p>
<p>Drawer bottom panel 23</p>  <p>X1</p>	<p>Drawer back panel 24</p>  <p>X1</p>		



SCREWS LIST

PART	QTY.	ITEM		PART	QTY.	ITEM	
A	12	6X40 MM		I	4	4X35 MM	
B	14	6X12 MM		J	12	5X45 MM	
C	6	6X25 MM		K	3	6X25 MM	
D	8	6X40 MM			1		
E	2	4X10 MM					
F	12	5X40 MM					
G	8	3X12 MM					
H	6	3X15 MM					

☛ This unit uses cam bolts and locks. The following explains how to use them. This is not an assembly step; it is a guide for when you are actually doing the assembly using this kind of hardware.

Cam Bolt



Cam Lock



1. Screw the bolt into the corresponding panel.

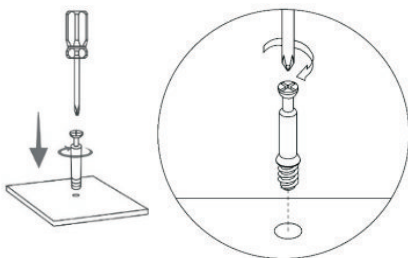

2. In the other panel, insert the cam lock and align it so it can properly receive the bolt, then join both panels (the cam locks might come pre-installed in this unit).

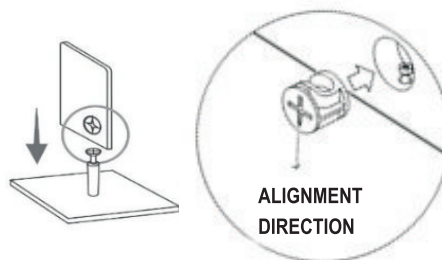

3. The panels might have a very small gap which is normal; turn the cam lock clockwise to lock the parts together and the gap will also close.

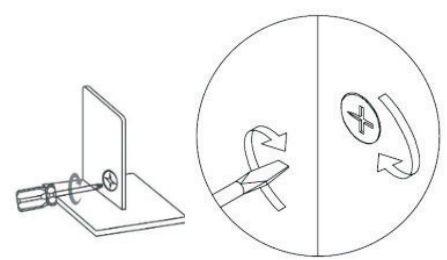

BEFORE YOU START THE ASSEMBLY, PLEASE READ THE FOLLOWING TIPS AND WARNINGS.

1 Do a quick inventory to make sure the package contains all the parts and hardware listed in the assembly instructions.



2 Missing, damaged and defective parts can be replaced at no cost to you. Please refer to the CONTACT card included with the product.



3 The replacement parts service is limited to the continental United States. If you reside in Hawaii, Puerto Rico, U.S. Dependencies or other countries, please contact the supplier from where the unit was purchased.



4 If during assembly you find an issue or need clarification, please contact our Customer Service for assistance. Please refer to the CONTACT card included with the product.



5 On each step read the instructions and analyze the illustrations thoroughly before proceeding to do the assembly.



6 Make sure you understand which hardware will be used on each step. Using the wrong size of screw, bolt or pin might strip the threads or cause damage to the part in which it is being used.

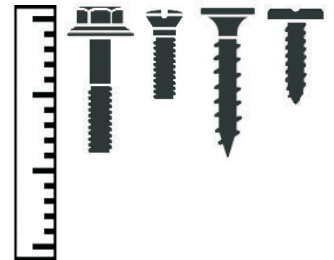

7 To avoid misalignments, always leave the screws loose and tighten them until all pieces are positioned correctly.

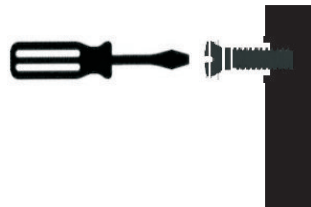

8 Do not overtighten or force the screws as they might break, strip, damage the threads of the holes or get stuck inside the part.

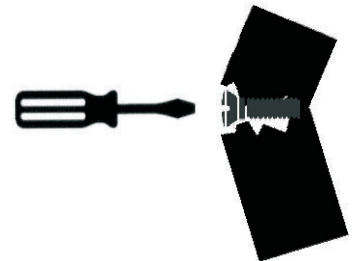

9 Sometimes the laminate might cover partially or entirely the hole on a panel. If there is no visible hole for the screw, pass and press the tip of your finger over the area where the hole should be located to feel the indentation, and once found, carefully pierce the laminate to reveal the hole underneath.



10 If the hole seems too small for the screw, first make sure you are using the correct size of screw and that it's been installed in the correct hole. If the hole still appears to be too small, carefully pierce the laminate to reveal the hole's actual size.



■ ASSEMBLY STEPS:

1 Assemble the legs ① to the main structure ② using screws ④ from above, but do not tighten the screws yet.

Do not tighten the screws

① X4

TWO PERSONS REQUIRED

■ SCREWS

④ 6X40 MM

x4

2 Assemble the legs ① to the main structure ② using screws ⑤ from underneath as shown, then proceed to tighten the screws ⑤ and ④.

① X4

■ SCREWS

⑤ 6X12 MM

x4

3 Assemble the leg supports ④ to the main structure ② and the legs ① using screws ⑤, then attach the studs ③ to the bottom of the legs as shown.

③ X4

① X4

②

④ X4

(Top)

■ SCREWS

⑤ 6X12 MM

x8

4

Assemble the external side panels ⑧ and ⑪ to the lower back panel ⑭ using bolts ① as shown and as explained in page 4.

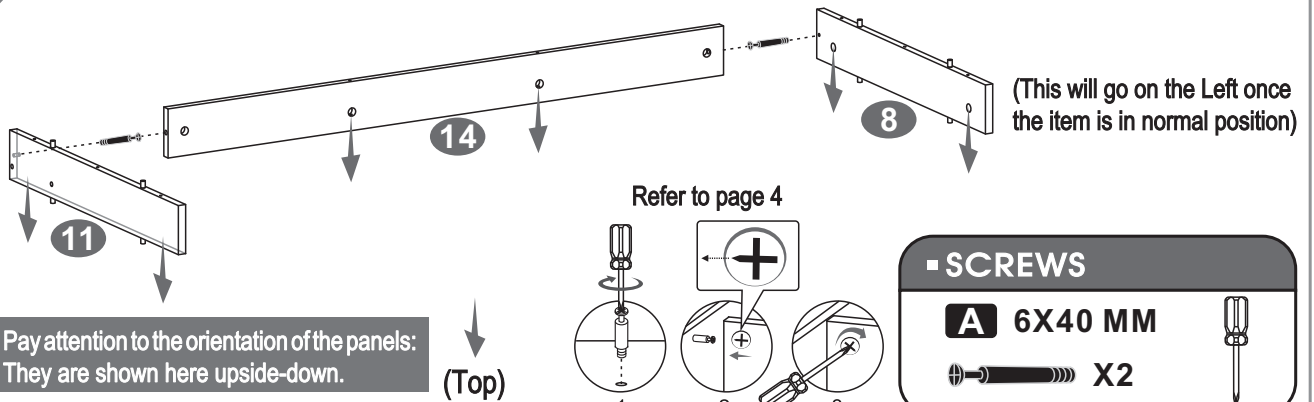

5

With the main panel ⑫ placed upside-down and its front edge towards you, assemble the external side panels ⑧, ⑪, ⑭ and the internal side panels ⑨ and ⑩ using bolts ① as shown and as explained in page 4.

Pay attention to the orientation of the panels 9 and 10: The holes for sliders (step 6) face towards the inside.

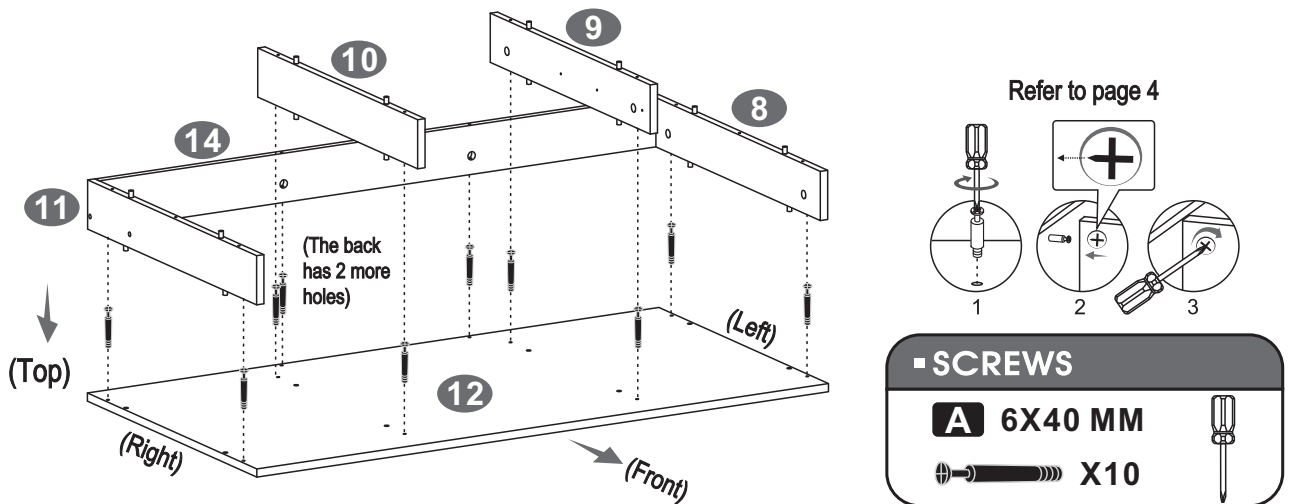

6

Open the sliders ⑲ slowly until you see the first hole on the back side of the slider thru the big opening, and using screws ① assemble the sliders to the internal panels ⑨ and ⑩ on the front as shown.

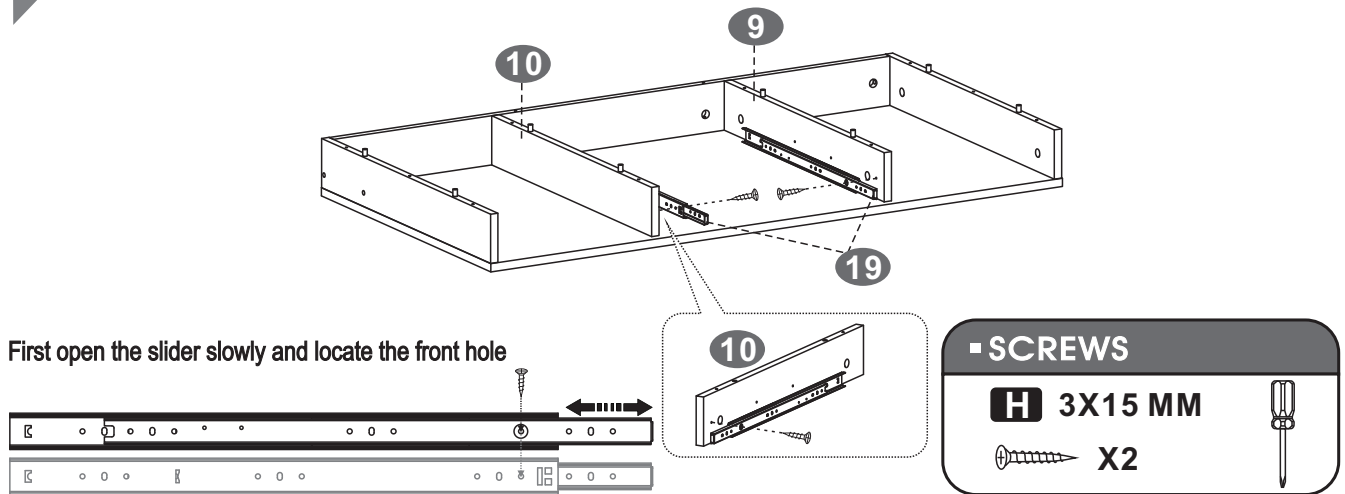

7

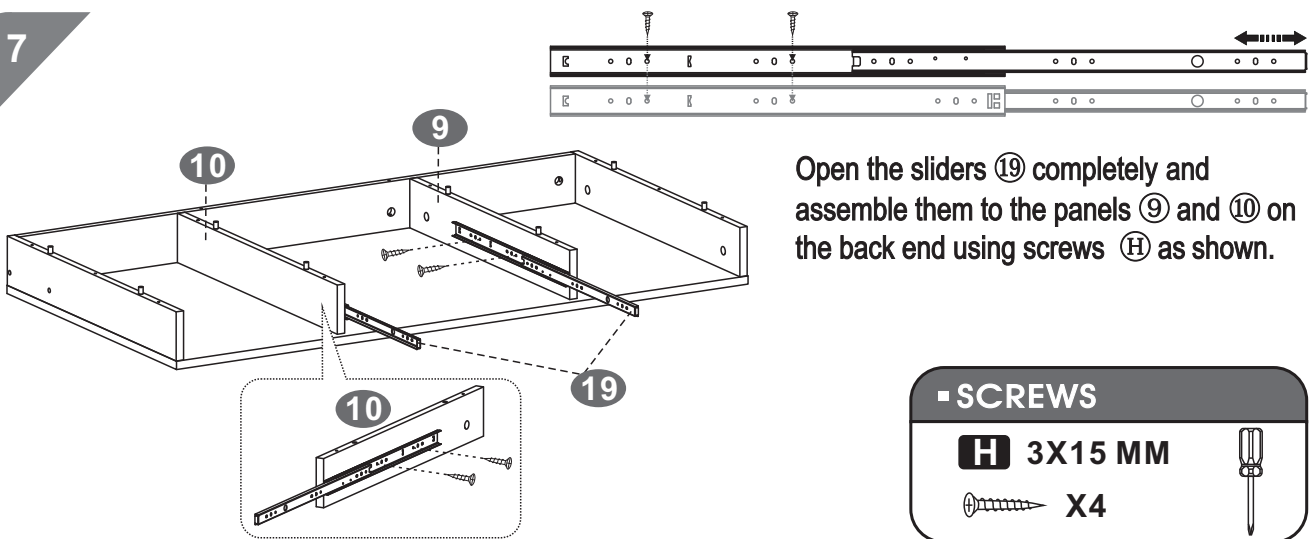

Open the sliders ⑲ completely and assemble them to the panels ⑨ and ⑩ on the back end using screws ④ as shown.

SCREWS

H 3X15 MM

X4



8

Assemble the bottom panel ⑬ to panels ⑧, ⑨, ⑩, ⑪ and ⑭ using screws ⑤ as shown.

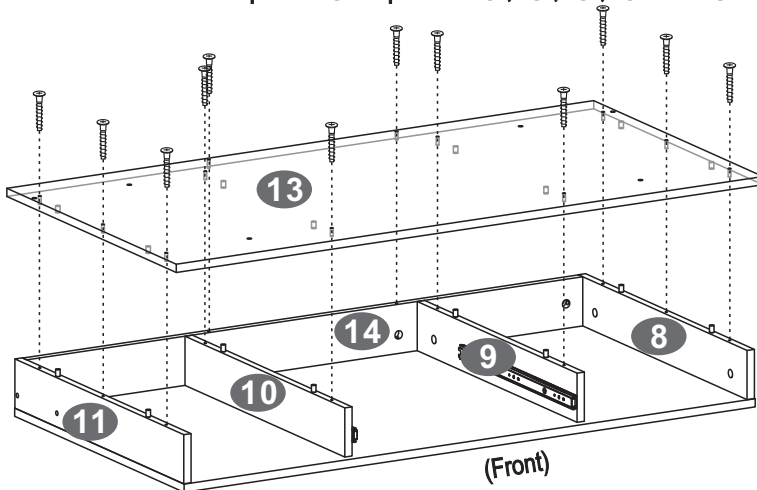

Pay attention to the orientation of panel 13: There are 2 more hole on the back.

TWO PERSONS REQUIRED

SCREWS

F 5X40 MM

X12



9

Assemble the main structure ② to the bottom panel ⑬ using screws ⑥.

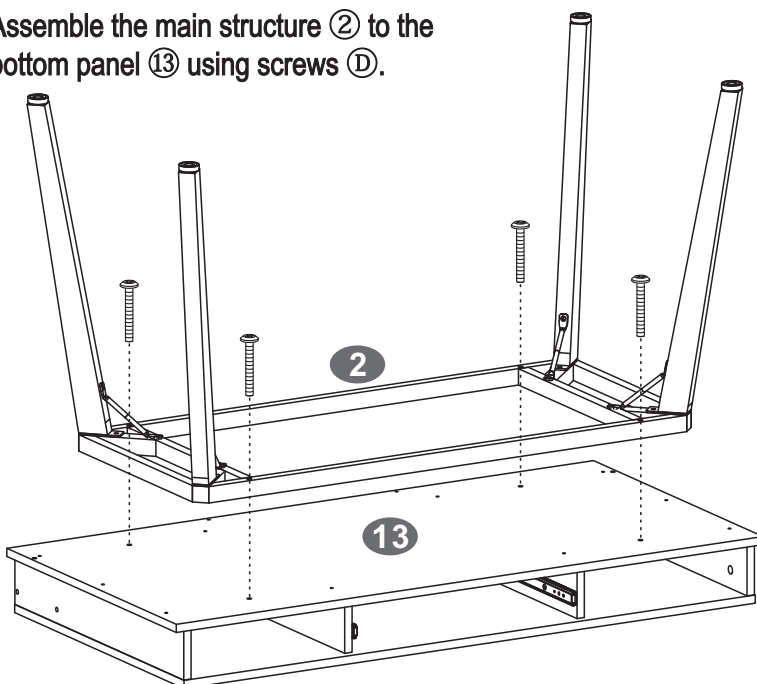

TWO PERSONS REQUIRED

SCREWS

D 6X40 MM

x4



10

Assemble the top shelf panel ⑮ to the upper back panel ⑯ using screws ⑰.

Pay attention to the orientation of panel 16: The cam locks must face towards the back of the unit (refer to step 11 or 14).

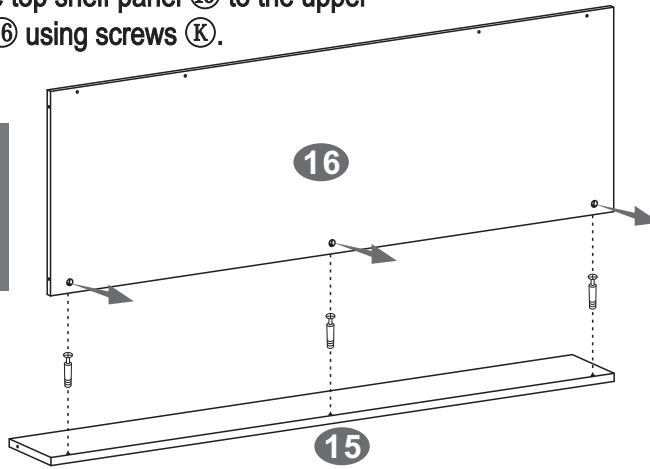

Refer to page 4

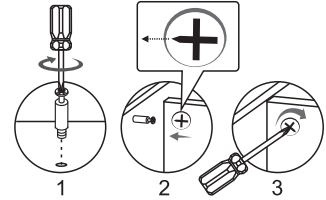

■ SCREWS

⑰ 6X25 MM

⑰ X3



11

Assemble the side structures ⑤ to panels ⑮ and ⑯ on both sides using screws ⑱ as shown.

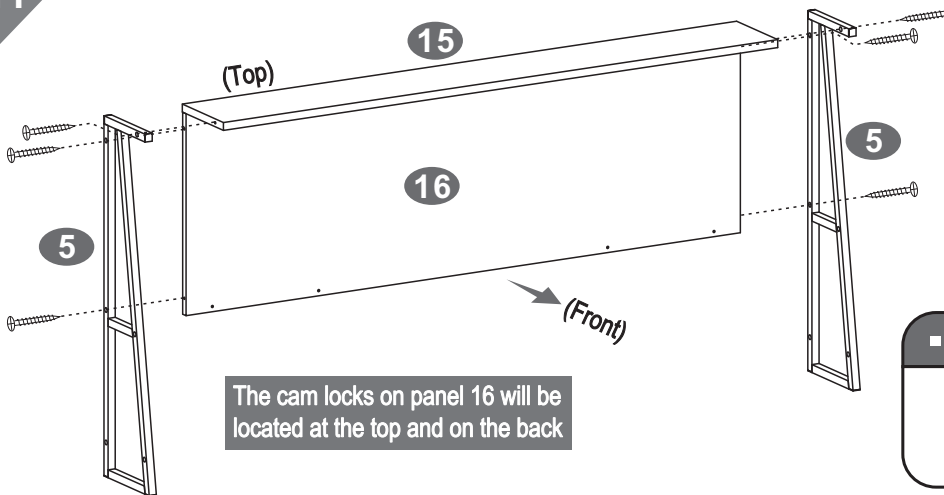

TWO PERSONS REQUIRED

The cam locks on panel 16 will be located at the top and on the back

■ SCREWS

⑱ 5X45 MM

⑱ X6



12

Use screws ⑱ to assemble the middle side shelves ⑰ and ⑲ on their respective sides, to the upper back panel ⑯ from behind and to the side structures ⑤ from the sides as shown.

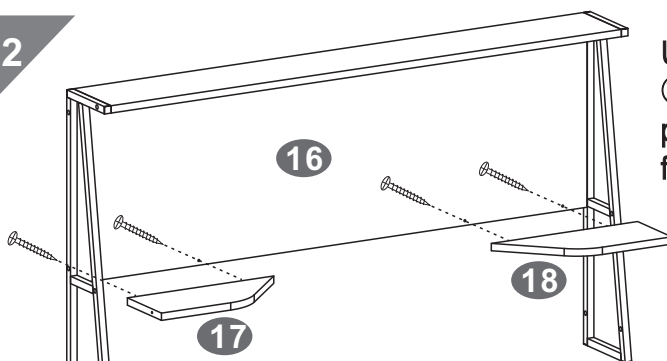

■ SCREWS

⑱ 5X45 MM

⑱ X6

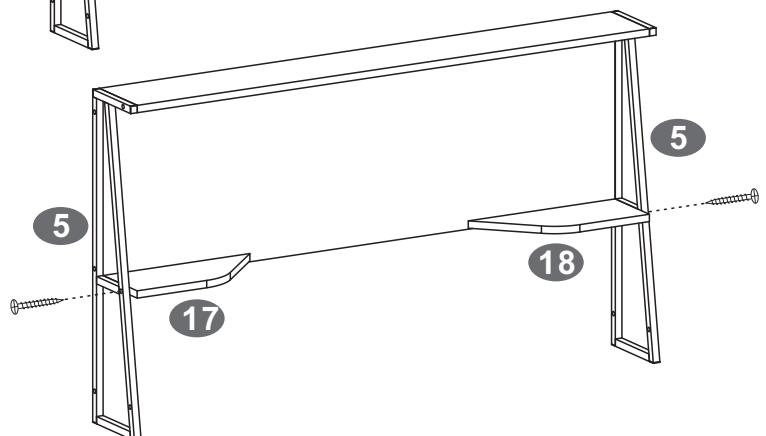

13

Assemble the accessory hanger ⑥ to the side structure ⑤ on the side of your preference using screws ④ from underneath.

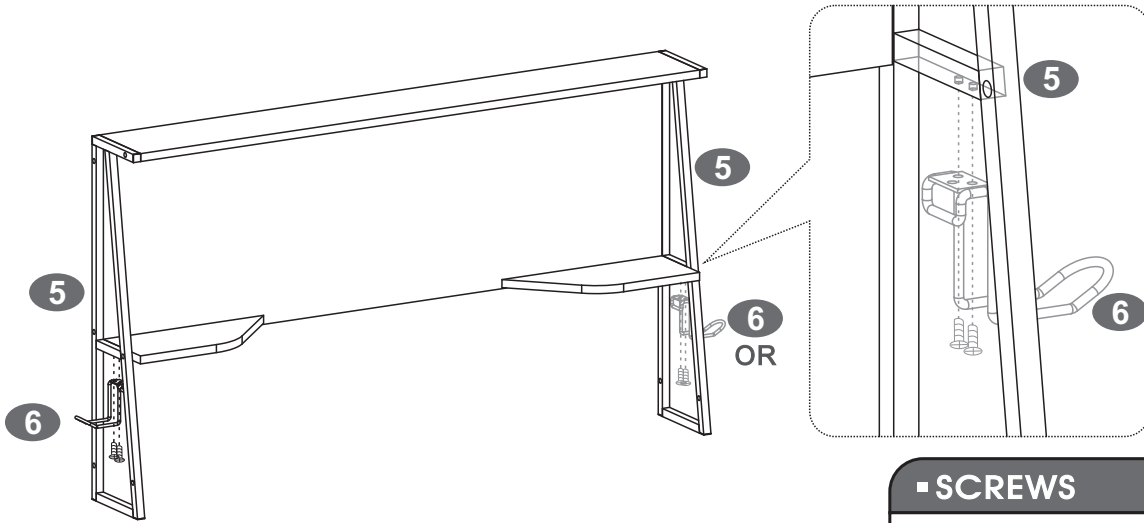

■ SCREWS

④ 4X10 MM

④ X2



14

With the help of another person, carefully turn the pieces assembled in step 9 upright into the normal position, and assemble the side structures ⑤ (from the previous step) to the bottom panel ⑬ using screws ④ from underneath as shown.

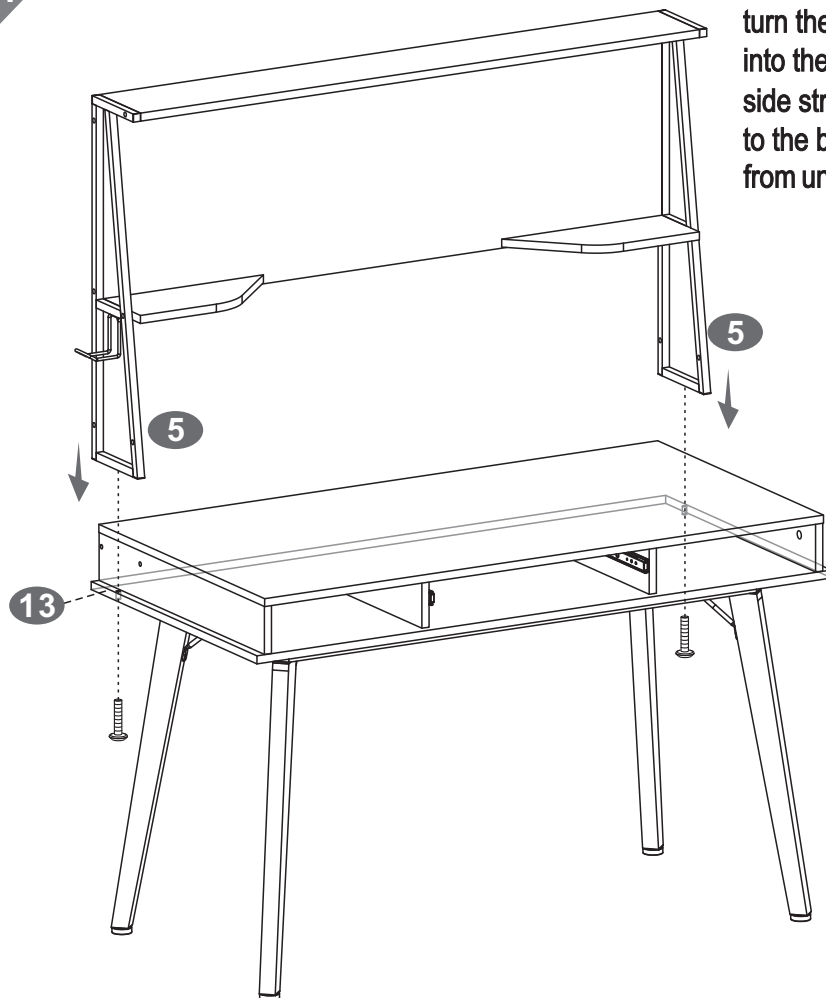

② ② TWO PERSONS REQUIRED

■ SCREWS

④ 6X25 MM

④ x2



15

Assemble the side structures ⑤ to the side panels ⑧ and ⑪ using screws ③ as shown.

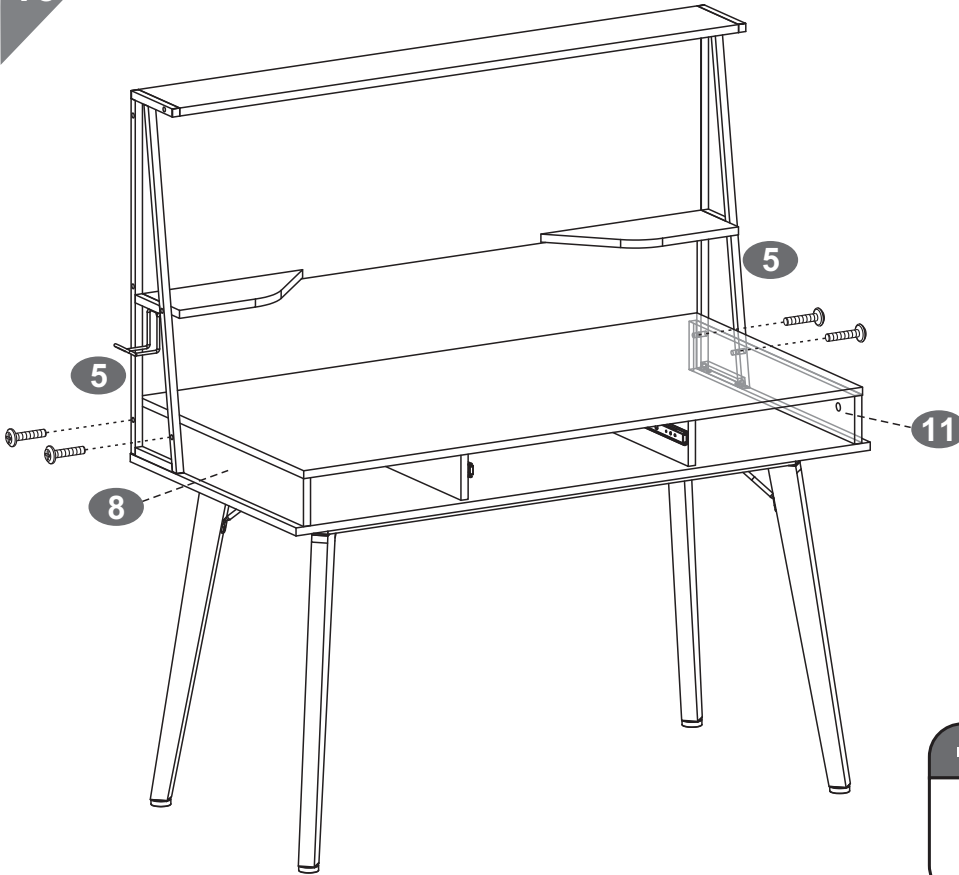

■ SCREWS

③ 6X25 MM

③ x4



16

Attach the drawer connectors ⑦ to the drawer side panels ⑳ and ㉓ using screws ④ as shown.

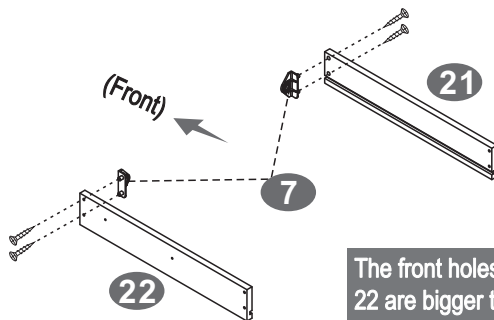

■ SCREWS

④ 3X12 MM

④ X4



17

Assemble the drawer back panel ㉔ to the side panels ㉑ and ㉓ using screws ⑤.

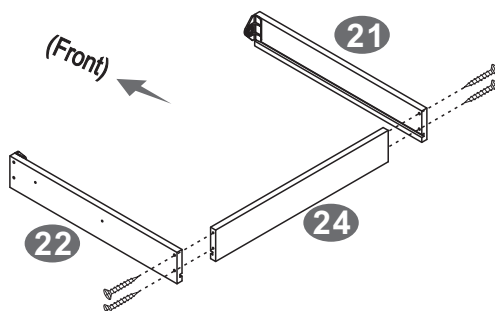

■ SCREWS

⑤ 4X35 MM

⑤ X4



18

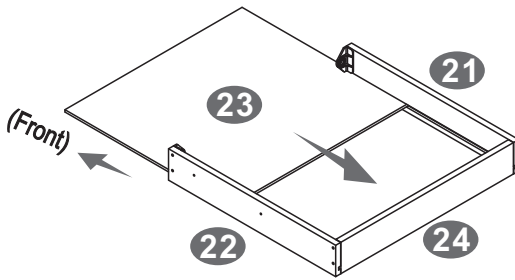

Insert the bottom panel ②③ thru the grooves on all panels as shown.

19

Assemble the drawer front panel ②④ to the connectors ⑦ using screws ②.

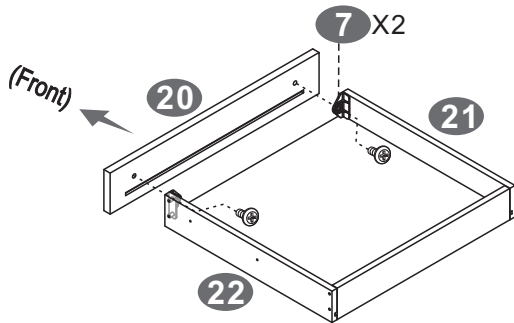

SCREWS

B 6X12 MM

x2



20

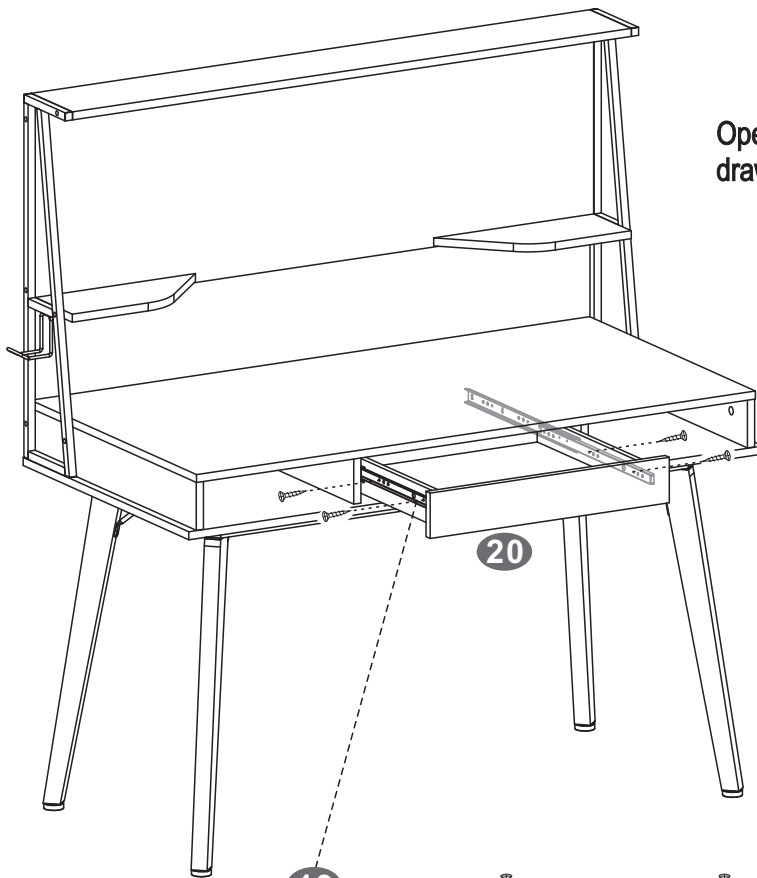

Open the sliders ①⑨ and assemble the drawer using screws ③ as shown.



SCREWS

G 3X12 MM

X4

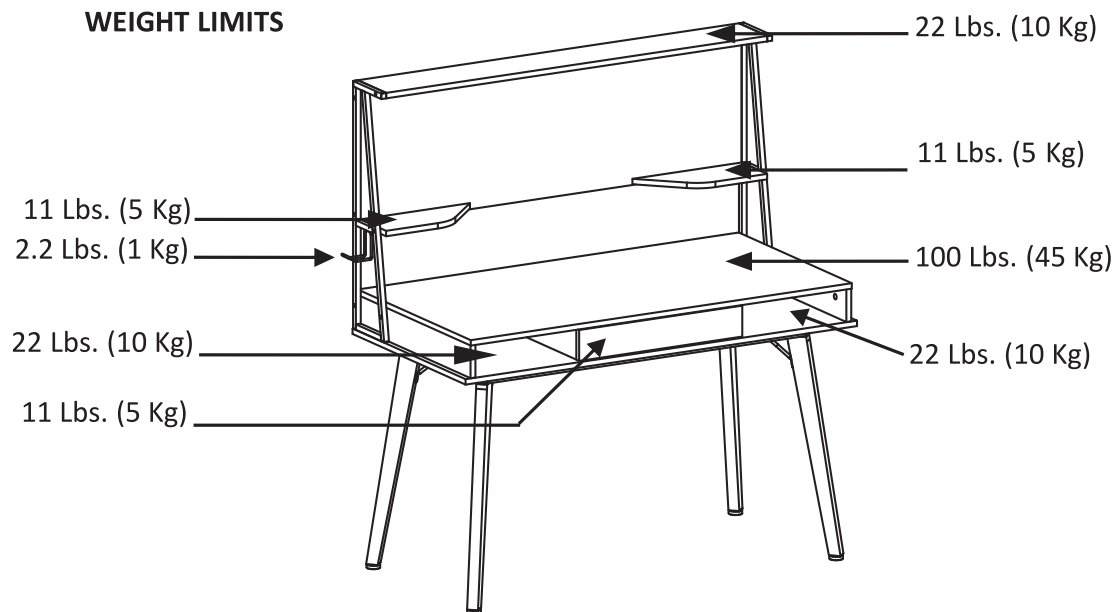

AFTER THE ASSEMBLY IS DONE, PLEASE READ CAREFULLY THE FOLLOWING CARE AND MAINTENANCE WARNINGS:

- Do not exceed the indicated weight limits.
- Do not expose the surfaces to direct sunlight or to extreme environmental conditions.
- Clean the surfaces preferable with a clean cloth damped in a solution of mild soap and water, then dry with a clean towel.
- Do not use solvents or abrasive materials to clean the unit.
- If you decide to use a cleaning agent, test first on an area hidden from view such as underneath the tabletop.
- Do not seat on the unit or lean against it.
- Do not allow small children to play under or over the unit.
- The unit must be handled by at least 2 persons when moving in the same or adjacent rooms.
- Before moving the unit, make sure to secure or remove any object that is heavy or might fall off.
- When lifting the unit, use both hands and bend your knees, not your backs.
- When transporting the unit to places far away, protect and secure the unit to avoid damage in transit. You may also disassemble it partially, please refer to steps 14 and 15.
- Shall any part of the unit become defective during the warranty period, replacement parts might be available to you at no charge. Please refer to the WARRANTY card included with the product.
- The warranty does not extend to regular wear and tear, nor the manufacturer assumes liability for damages or consequences due to accidents, incorrect assembly, negligence, improper use, modifications, or not heeding the above warnings.
- The warranty is limited to the continental United States. If you reside in Hawaii, Puerto Rico, U.S. Dependencies or other countries, please contact the supplier from where the unit was purchased.