

**MODELS**

**RTA-3930SU**

**RTA-3940SU**

**ASSEMBLY INSTRUCTIONS**

Thank you for purchasing our product.

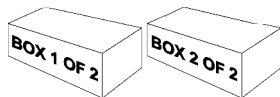
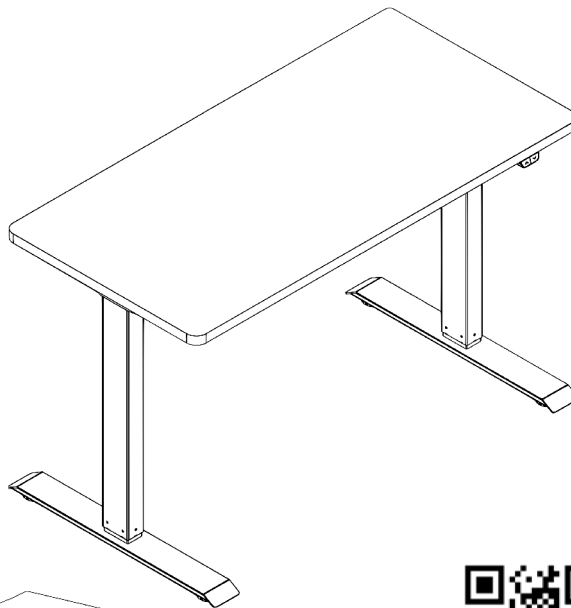

**Please note that this product comes packaged in 2 separate boxes.**



Scan QR code to view assembly video

REV.LTK-6666-0422-2





- The product comes packaged in 2 separate boxes.



110V-240V

- The unit requires AC power supply 100V-240V.

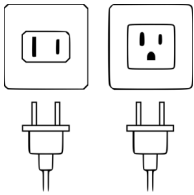

- The unit plugs into an electrical outlet type A or B.



- Please read carefully the assembly instructions before the installation.



- Do not discard this manual or any of the packaging material until the unit has been completely assembled.



- Will require two people.



SAMPLE – DO NOT SCAN



- Scan the QR code shown in the front page to view the complete assembly video online.
- We have added QR Codes to some steps for your assistance. If a QR code is provided on a step, scan it to view the assembly video online.

## MAIN PARTS LIST

**1** Metal foot  
x2

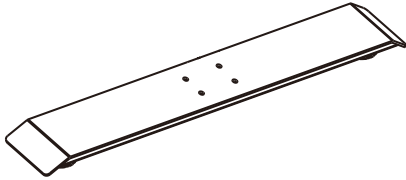

**2** Leg without motor  
x1



**3** Leg with motor  
x1



**4** Adjustable support beam  
x1

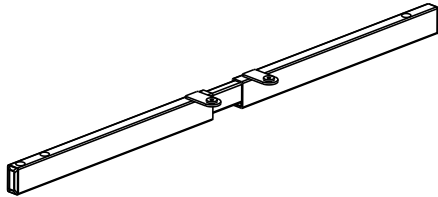

**5** Transmission rod  
x1



**6** Support plate  
x2

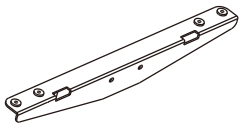

**7** Power adapter  
x1

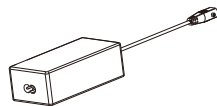

**8** Metal covers  
(for the beam)  
x2

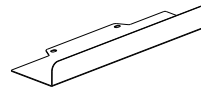

**9** Power cable  
x1



**10** Cable tie  
x4

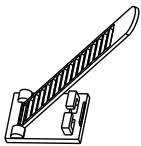

**11** Metal holder  
(for adapter)  
x1

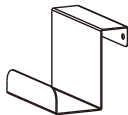

**12** Tabletop  
x1

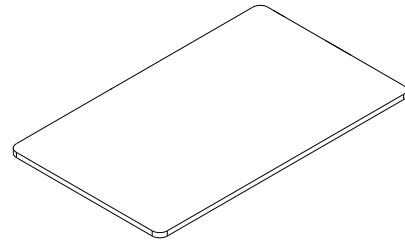

**13** Handset  
x1

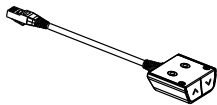

**14** Switch cord  
x1

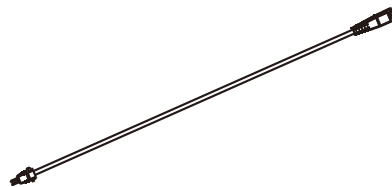



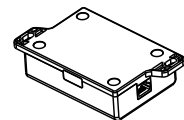

**15** Control box  
x1

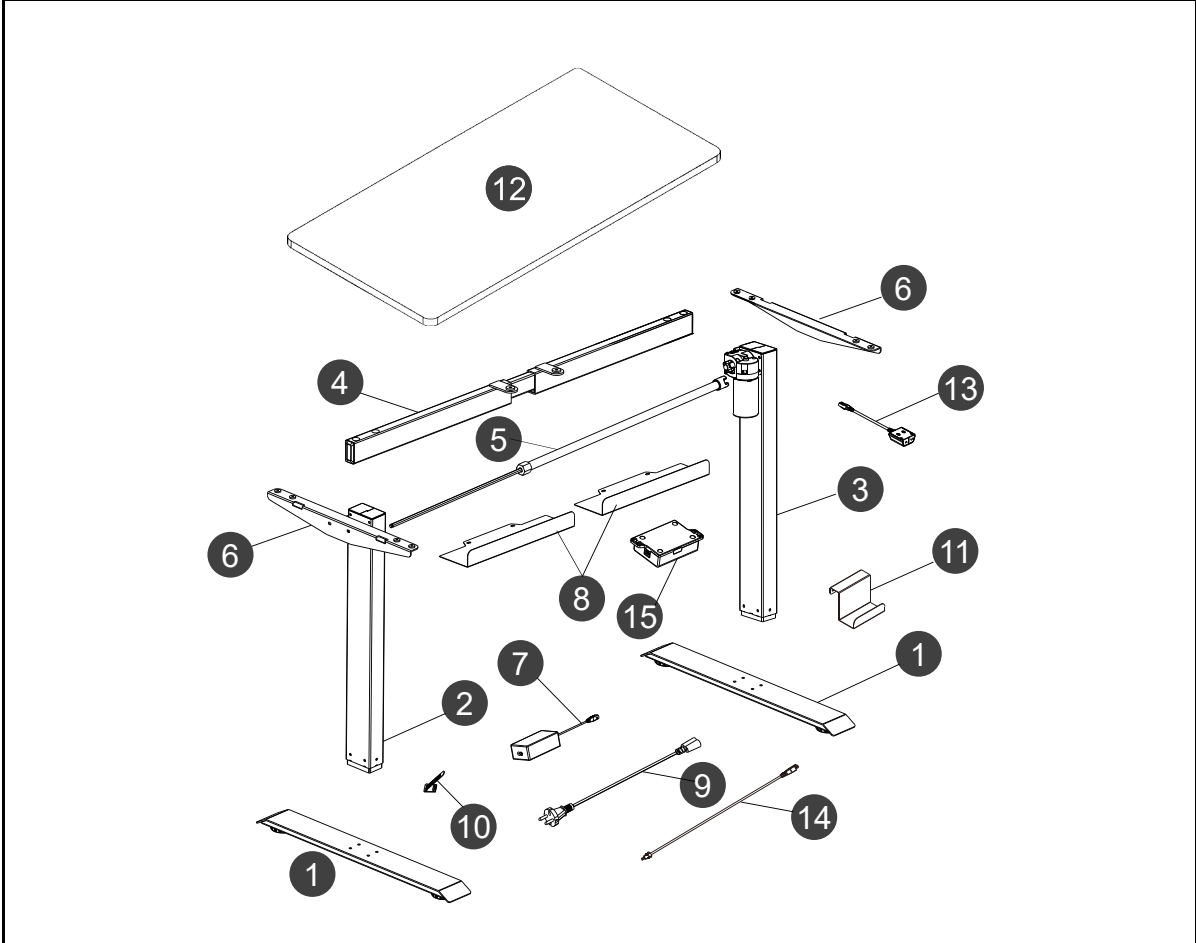



**MAIN PARTS LAYOUT (FOR REFERENCE):**



**LIST OF HARDWARE, SCREWS AND FITTINGS**

PART	QTY	ITEM	
A	12	M6x16	
B	4	M8x50	
C4	1	4x4 Allen key	
C5	1	5x5 Allen key	
D	1	2.5x2.5 Allen key	

PART	QTY	ITEM	
E	4	M4x6	
F	14	M4.2x19	
G	1	Hex wrench (Spanner)	

**NOTE:**  
 You will also need during assembly a Phillips screwdriver which is not included with the product.



**BEFORE YOU START THE ASSEMBLY, PLEASE READ THE FOLLOWING TIPS AND WARNINGS.**

**1** Do a quick inventory to make sure the package contains all the parts and hardware listed in the assembly instructions.



**7** To avoid misalignments, always leave the screws loose and tighten them until all pieces are positioned correctly.

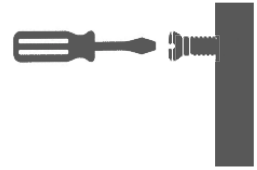

**2** Missing, damaged and defective parts can be replaced at no cost to you. Please refer to the last pages on this manual.



**8** Do not overtighten or force the screws as they might break, strip, damage the threads of the holes or get stuck inside the part.

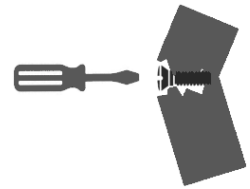

**3** The replacement parts service is limited to the 48 contiguous United States. If you reside in Alaska, Hawaii, Puerto Rico, U.S. territories or other countries, please contact the supplier from where the unit was purchased.



**9** Sometimes the laminate might cover partially or entirely the hole on a panel. If there is no visible hole for the screw, pass and press the tip of your finger over the area where the hole should be located to feel the indentation, and once found, carefully pierce the laminate to reveal the hole underneath.



**4** If during assembly you find an issue or need clarification, please contact our Customer Service for assistance. Please refer to the last pages on this manual.



**5** On each step read the instructions and analyze the illustrations thoroughly before proceeding to do the assembly.



**10** If the hole seems too small for the screw, first make sure you are using the correct size of screw and that it's been installed in the correct hole. If the hole still appears to be too small, carefully pierce the laminate to reveal the hole's actual size.



**6** Make sure you understand which hardware will be used on each step. Using the wrong size of screw, bolt or pin might strip the threads or cause damage to the part in which it is being used.

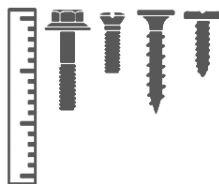

**ASSEMBLY STEPS**

**STEP 1**

**Hardware:**

**A**



M6x16

8  
Pcs

**C5**



5x5



Scan QR Code to view this step

Use the key **C5** to assemble the metal feet **1** to the legs **2** and **3** with screws **A**.

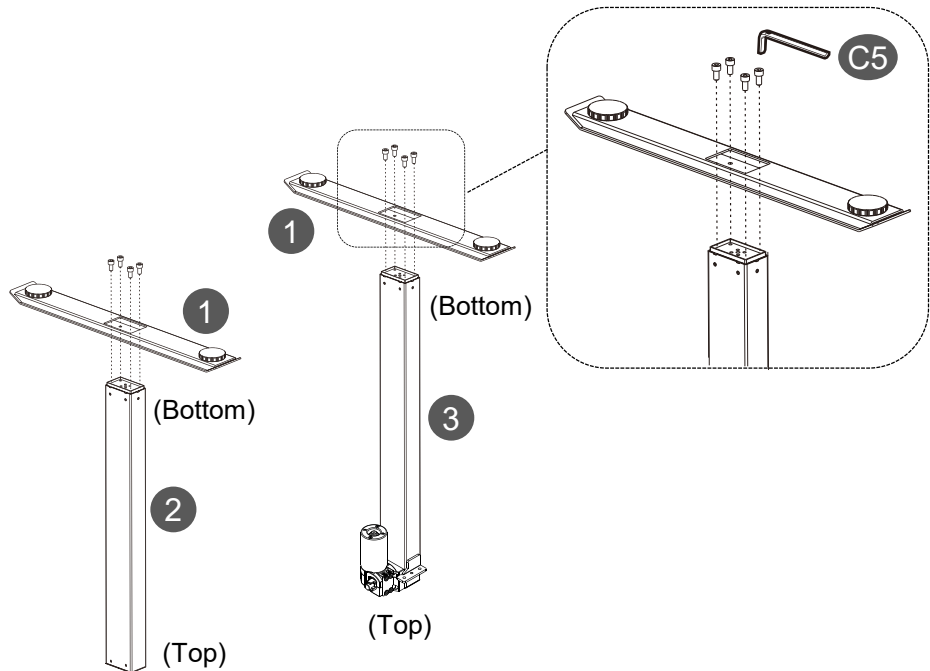

**STEP 2**

**Hardware:**

**C4**



4x4



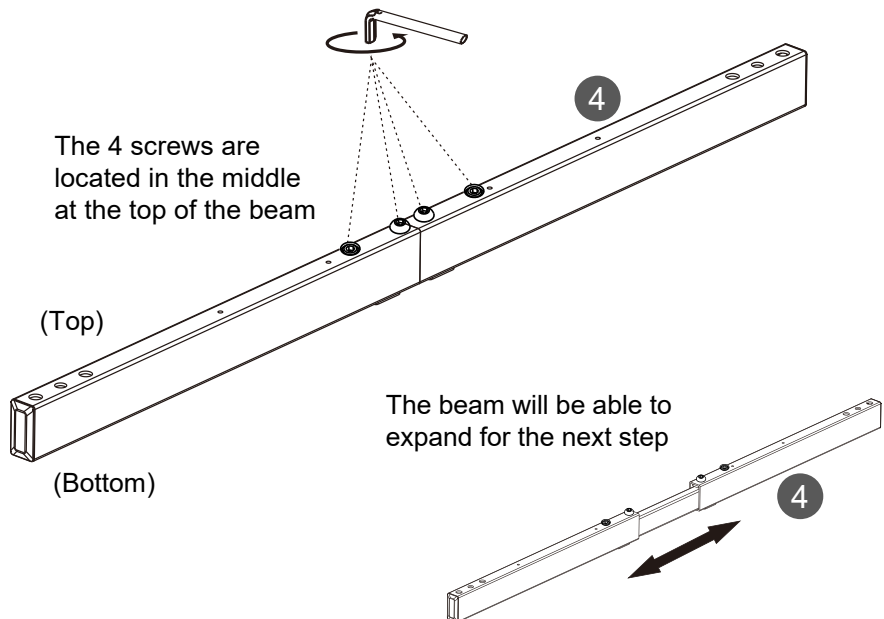

Scan QR Code to view this step

- Use the key **C4** to loosen up all the screws on the middle of the support beam **4** to allow the beam to expand.

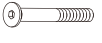

## STEP 3

## Hardware:

B		4
	M8x50	Pcs
C5		
	5x5	

- Place the adjustable support beam **4** over the brackets of the legs **2** and **3** with the beam tabs facing **UP**.
- Use the key **C5** to assemble the adjustable support beam **4** to the legs **2** and **3** with screws **B**.



Scan QR Code  
to view this step

Tabs facing UP

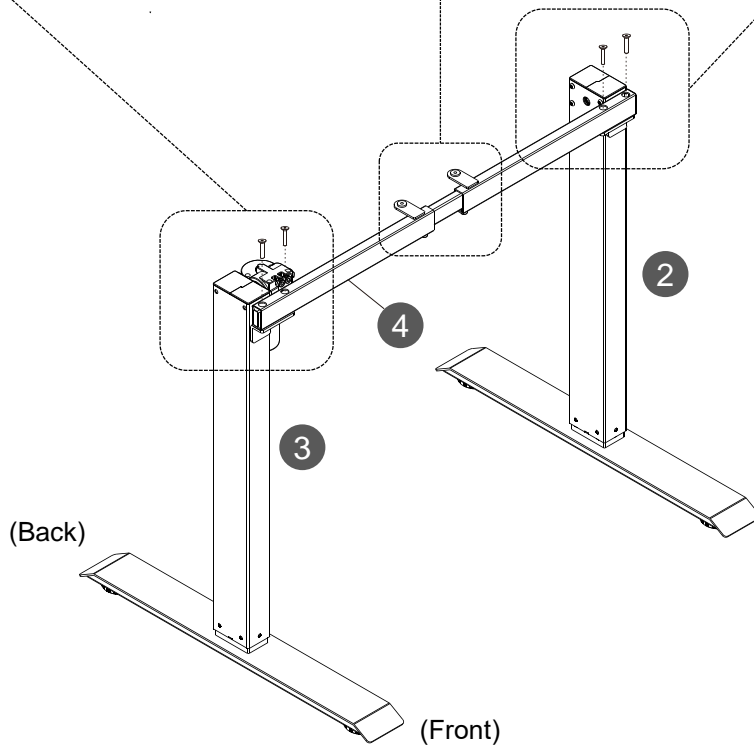
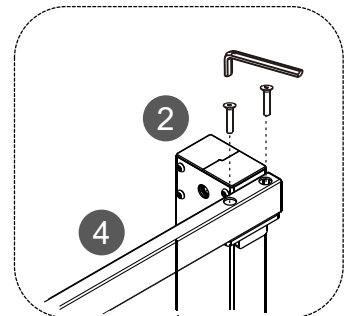
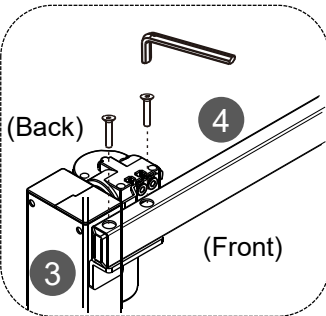
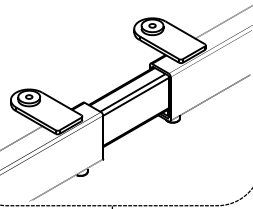

## STEP 4

## Hardware:

D



2.5x2.5

G

Scan QR Code  
to view this step

- Use the hex wrench (spanner) **G** to loosen up the nut on the transmission rod **5** to allow it to expand, and insert the inner rod into the hole of the leg **2**, but **DO NOT TIGHTEN** the nut, this is done until step **8**.
- On the other end of the transmission rod **5**, connect its plastic gear to the gear on the leg with motor **3** making sure the hole with screw on the transmission rod faces **UP**.
- Tighten the screw to secure the gears together.

## 1. Loosen up

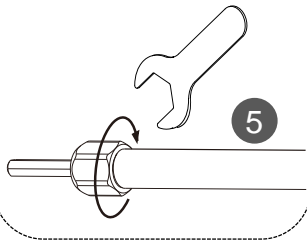

## 2. Insert but DO NOT TIGHTEN

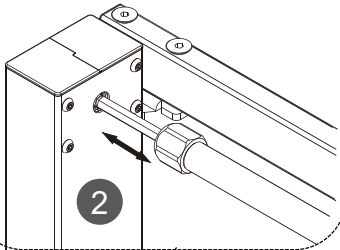

## 3. Hole on gear must face UP

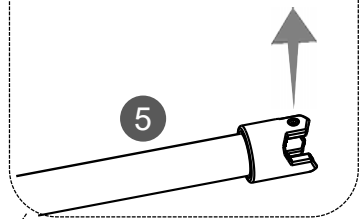

## 4. Connect gears

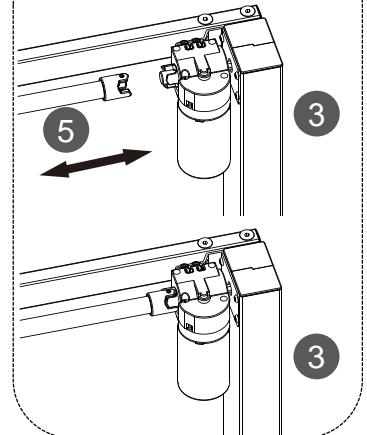

## 5. Tighten screw

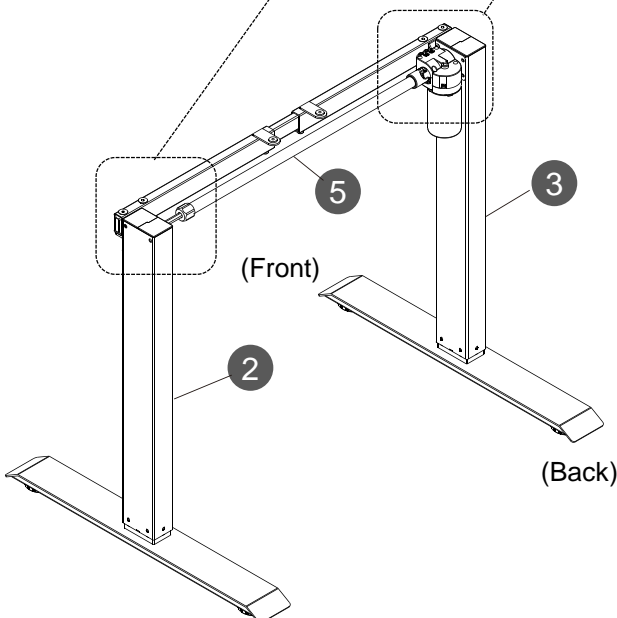
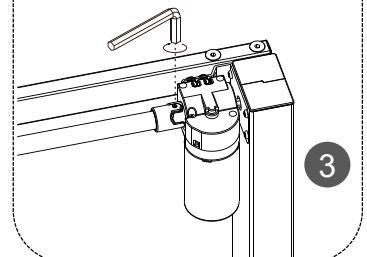



**STEP 5**

**Hardware:**

**A**



M6x16

4  
Pcs

**C5**



5x5



Scan QR Code to view this step

Use the key **C5** to assemble the support plates **6** to the legs **2** and **3** with screws **A**.

**NOTE:** The metal plates might have small rubber grommets, if that is the case, DO NOT REMOVE THEM.

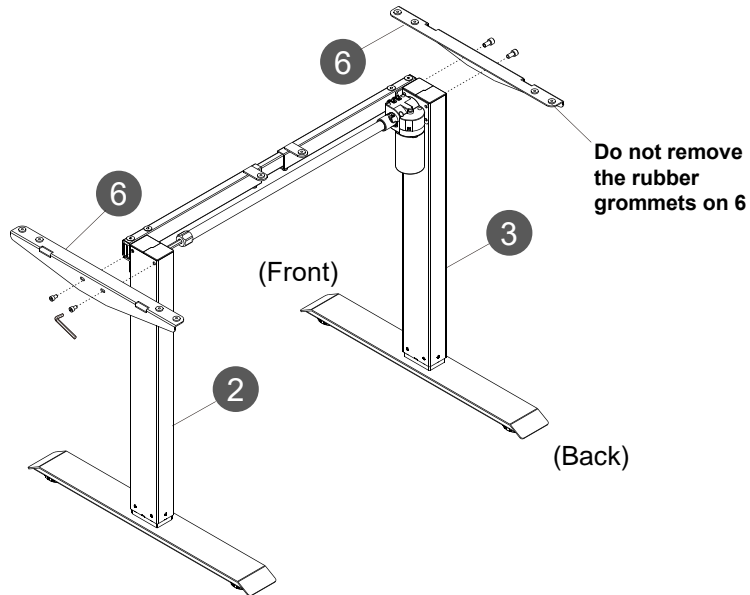

**STEP 6**



Scan QR Code to view this step

- With the help of another person, place the tabletop **12** upside-down over carpeting or large blanket to protect its top surface.
- With the help of another person, place the frame over the tabletop **12** and slide the metal holder **11** under the beam **4** near the leg with motor **3**.

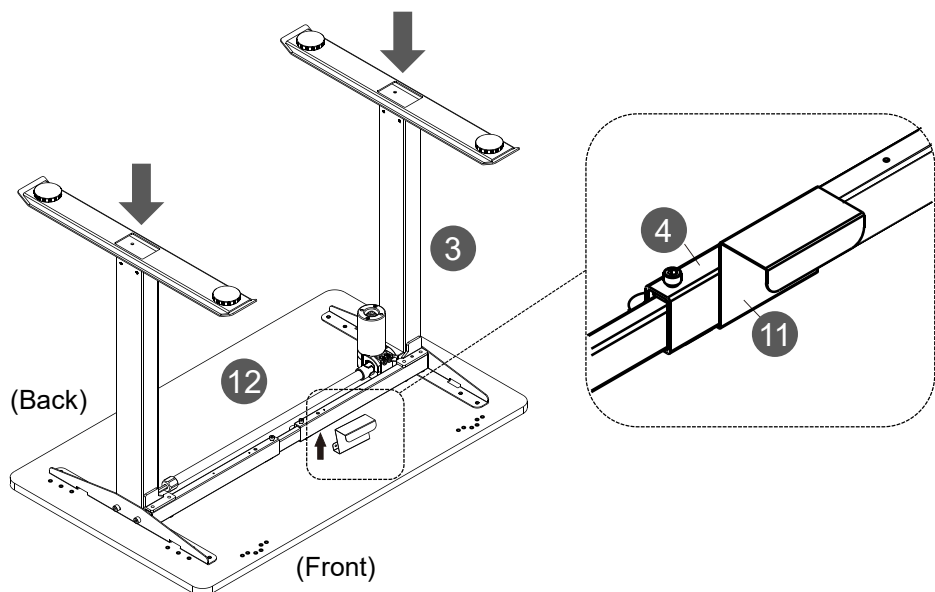

## STEP 7

## Hardware:

F

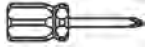
12  
Pcs

(NOT INCLUDED)

Scan QR Code  
to view this step

- With the help of another person, expand or retract the beam **4** to make the holes on the support plates **6** align with the pre-drilled holes on the tabletop **12**.
- Use a Phillips screwdriver (not included) and screws **F** to assemble:
  1. The metals plates **6** to the tabletop **12**.
  2. The handset **13** to the tabletop **12** on the side of your choice (left or right). Please note that there will be extra holes intended for other style of this product.
  3. The tabs from the beam **4** to the tabletop **12**.

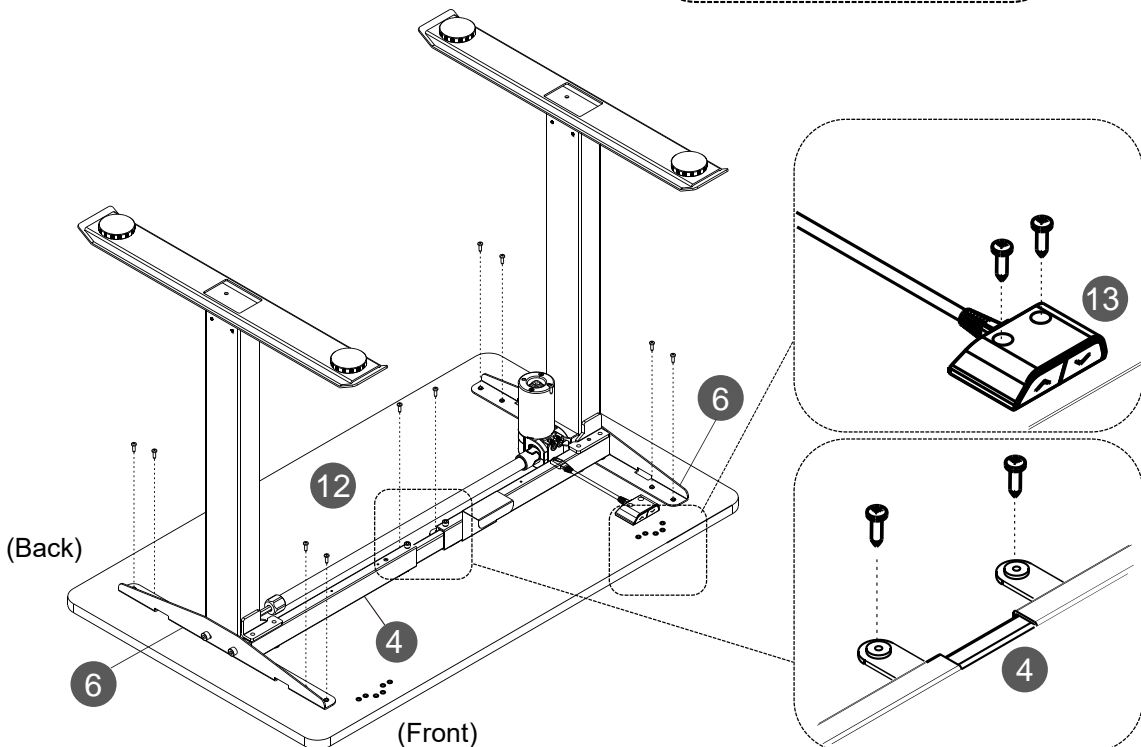
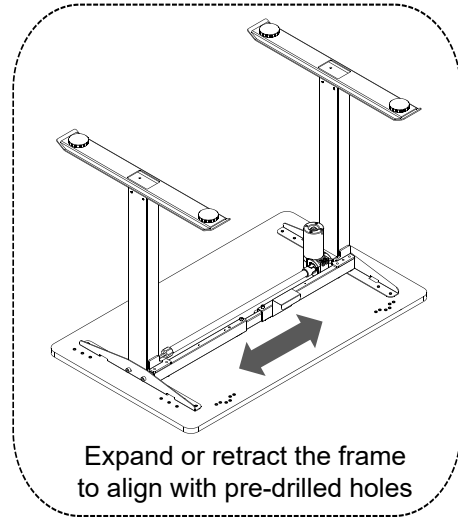

## STEP 8

## Hardware:

C4



4x4

G

Scan QR Code  
to view this step

- Use the key **C4** to re-tighten all the holes on the middle of the beam **4**.
- If the transmission rod **5** detached from the leg **2** in the previous steps, go ahead and re-insert it, then use the hex wrench (spanner) **G** to tighten the nut.

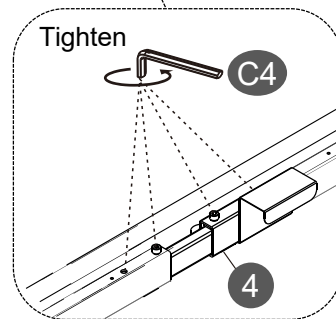
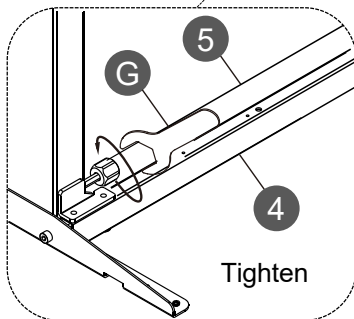
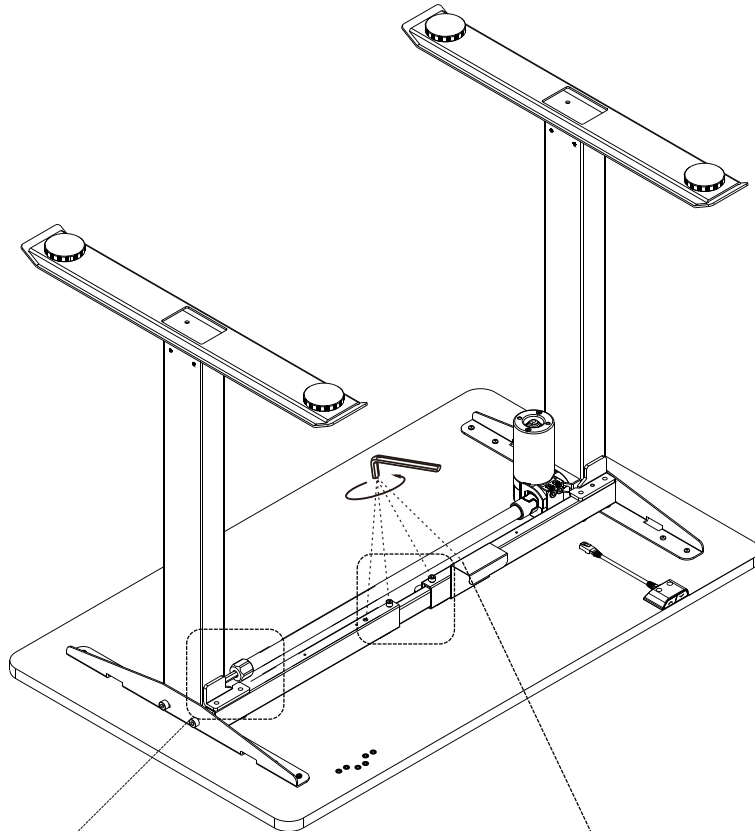

## STEP 9



Scan QR Code  
to view this step

Without attaching them to the unit, make the following connections:

- The cable from the handset **13** to the control box **15** in its respective receiving port.

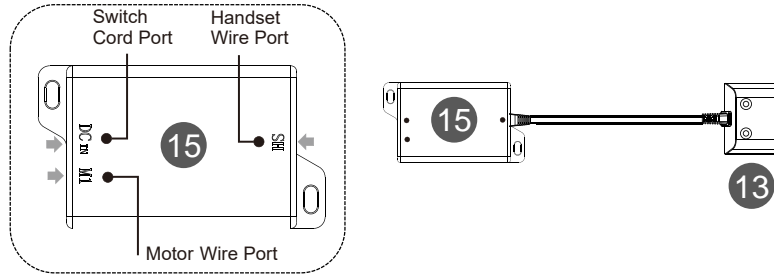

- The cable from the motor on the leg **3** to the corresponding port on the control box **15**.

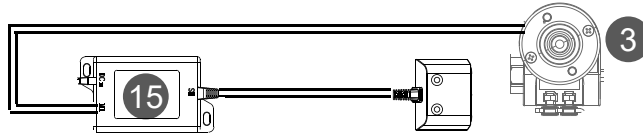

- The switch cord **14** to the port on the control box **15** and to the receptacle cable on the power adapter **7**.

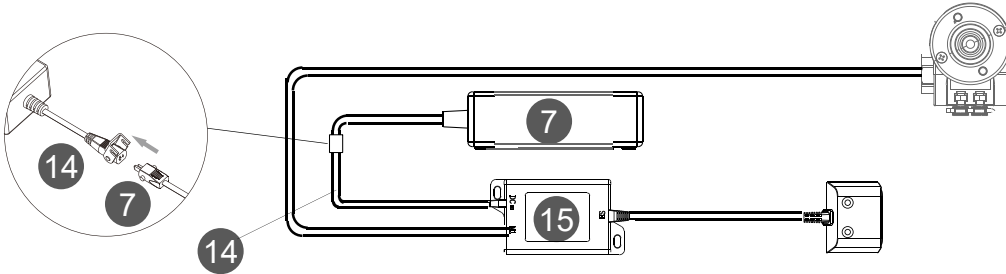

- The power cable **9** to the port on the power adapter **7**.

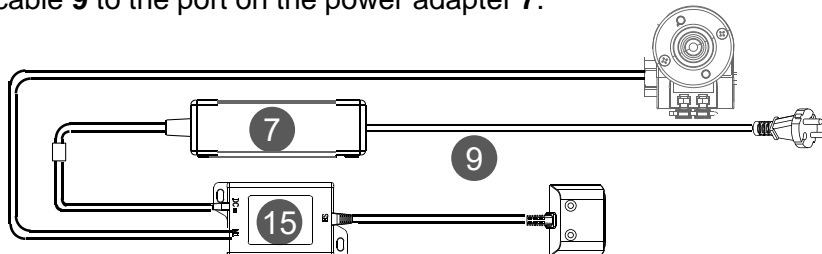

- The power cable **9** to a **110-240V** power outlet type A or B (2-prong). Please check first if the electrical voltage for the power outlet you intend to use is suitable before connecting.

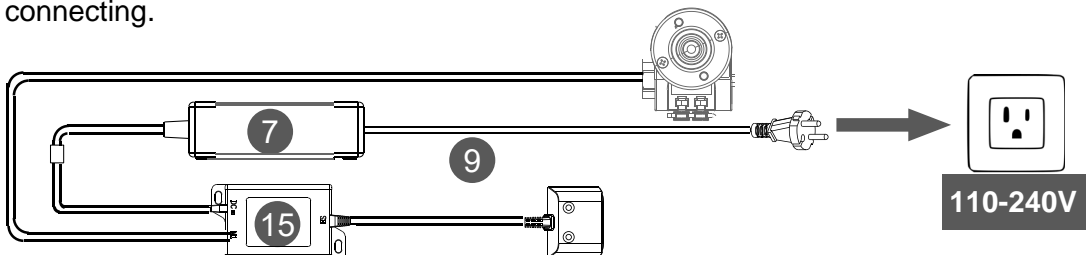

**STEP 10**



Scan QR Code to view this step

It is important to do a lift test before proceeding.

- Stay clear of the legs as they will move up and down during the test.
- Press the **UP** and **DOWN** arrows on the handset **13** to make sure the legs rise/lower simultaneously.
- If the unit works fine, set the legs to the lowest position and disconnect the power cable **9** from the power supply.
- If none of the legs rise, review all the connections made in step **9**.
- If the leg without motor **2** does not rise, review the assembly for the transmission rod **5** done in steps **4** and **8**.

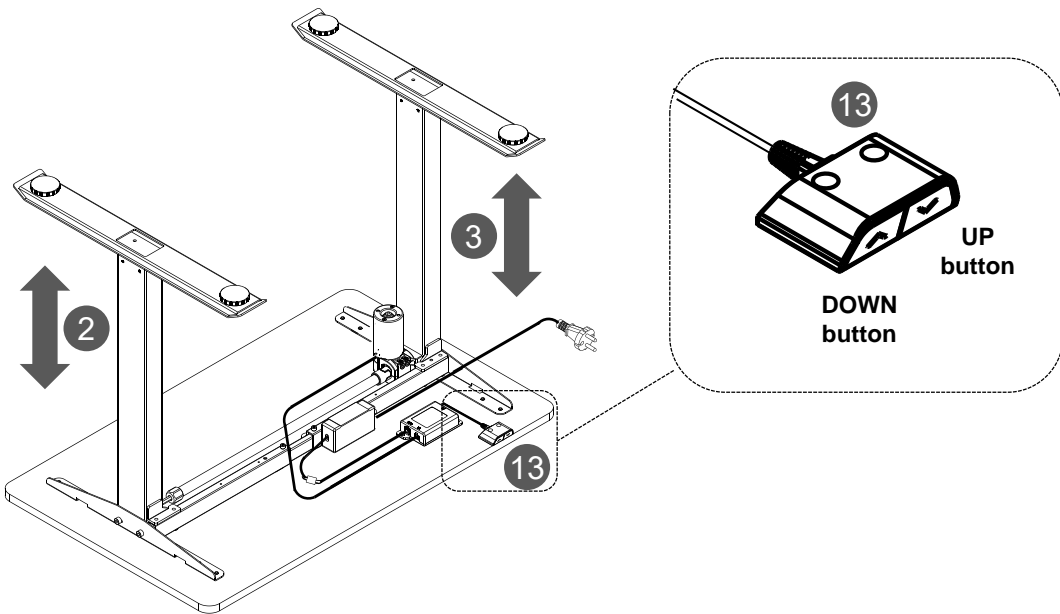

**STEP 11**

**Hardware:**

<b>D</b>		2.5x2.5
<b>E</b>		4 Pcs



Scan QR Code to view this step

After the lift test is done, use the key **D** to attach the metal covers **8** to the beam **4** with screws **E**.

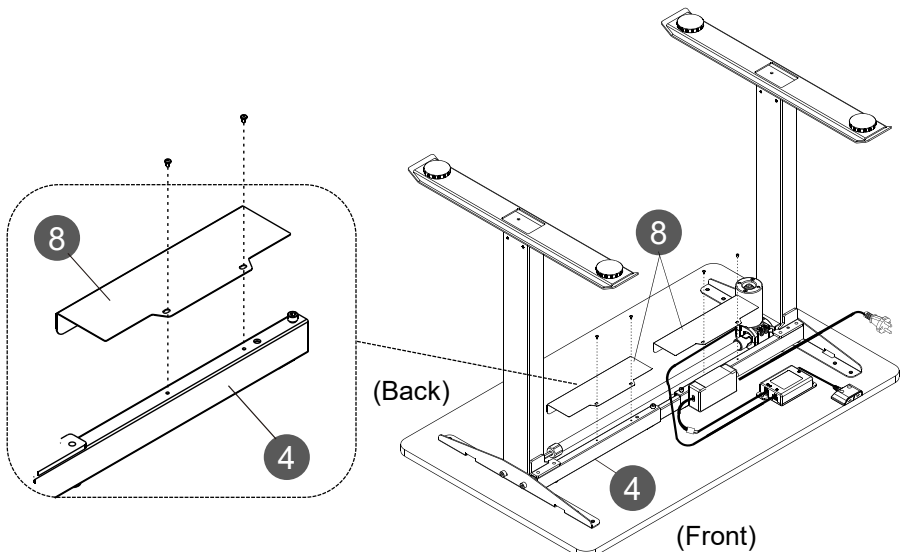

## STEP 12

## Hardware:

F

2  
Pcs

(NOT INCLUDED)

Scan QR Code  
to view this step

- Use a Phillips screwdriver (not included) to attach the control box **15** to the tabletop **12** with screws **F**. Please note that there are no pre-drilled holes for it, you can attach anywhere on the panel.
- Slide the power adapter **7** into the holder **11**.
- Tear-off the cable ties **10** and attach them to the tabletop **12**, then use them to hold and secure the cables from all the wired connections.

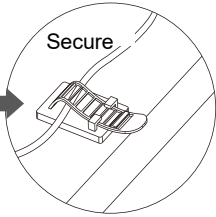
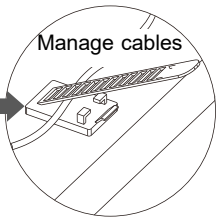
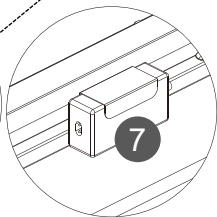
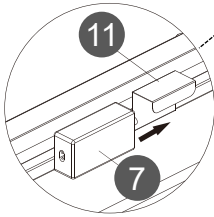
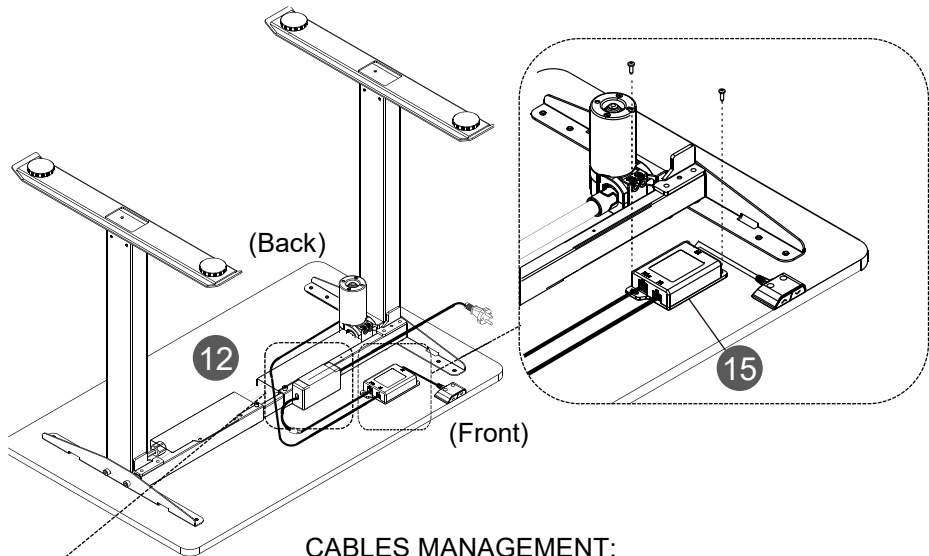

## STEP 13

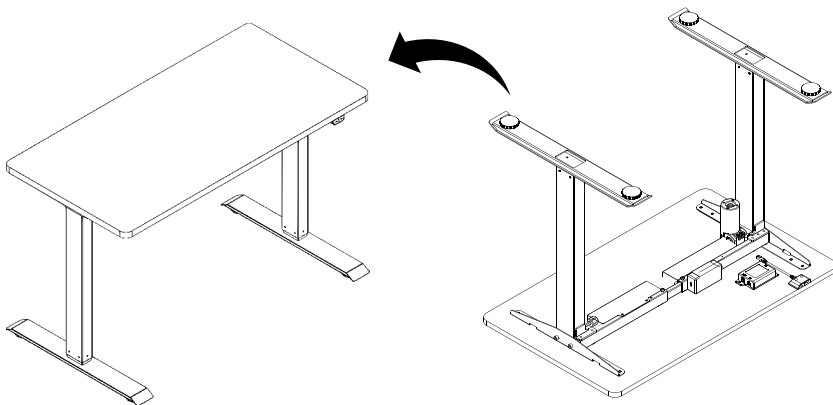

- With the help of another person, bring the unit upright.
- Re-connect the power cable to the electrical outlet.

Scan QR Code  
to view this step



## ALL DONE!

Give yourself a nice pat on the back. You did a great job!

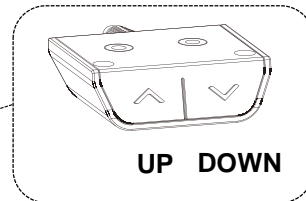
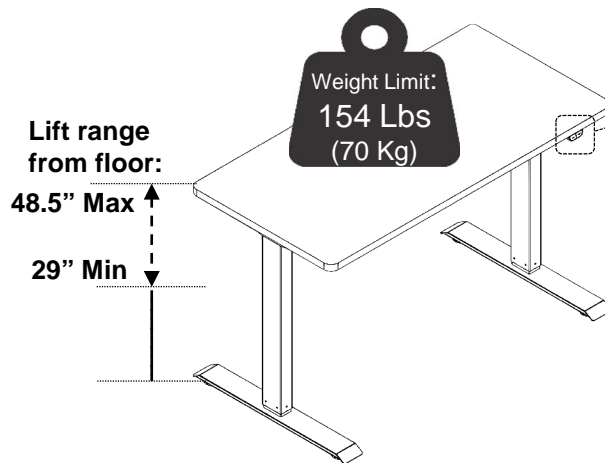

Press the UP or DOWN buttons to adjust the height of the unit and release the buttons when the desired height is reached.

If the handset becomes unresponsive, do a reset by keeping the DOWN button pressed, the unit will come down to the lowest position and will rebound to stop, then release the button. Wait 20 seconds before operating the handset again.

Sometimes the handset becomes unresponsive even after doing a reset, so if this is the case, please unplug the unit from the power supply and wait for 18 minutes (the maximum duration of the duty cycle) before plugging and using again.

### TROUBLESHOOTING NORMAL ISSUES

Issue	Try this
Table does not go up or down when operating the handset	<ul style="list-style-type: none"> <li>• Check the connections of all the cables as explained in page 11.</li> <li>• Do a reset.</li> <li>• Unplug and wait for at least 18 min. before operating again.</li> </ul>
Only the leg with the motor goes up or down	Check the correct assembly of the transmission rod as explained in page 7.
Unit rises extremely slowly	Check for weight overload and test by removing some of the heavy objects from the unit.
Unit lowers itself down	Check for weight overload and test by removing some of the heavy objects from the unit.
Unit does not reach the maximum or minimum heights	Do a reset.
Button pressed but the unit moves in the opposite direction	Do a reset.

### TECHNICAL DATA

Input voltage	100V-240V, 50/60Hz
Duty cycle (power cycle)	10%: 2 min on at most, 18 min. off.
Tolerable ambient temperature	32-104°F (0-40°C)
Max. lift speed	59 in/min (25mm/s)

### CARE, MAINTENANCE AND SAFETY WARNINGS:

- Do not exceed the indicated weight limits.
- Do not expose the surfaces to direct sunlight or to extreme environmental conditions.
- Unplug the unit from its power supply before cleaning the unit.
- Clean the surfaces preferable with a clean cloth damped in a solution of mild soap and water, then dry with a clean towel.
- Do not use solvents or abrasive materials to clean the unit.
- If you decide to use a cleaning agent, test first on an area hidden from view such as underneath the tabletop.
- Do not sit on the unit or lean against it.
- Do not allow small children to play under or over the unit.
- Do not allow small children to operate the handset without your supervision.
- Do not pull, push or drag the unit to move it for more than 1 feet. The unit must be lifted by at least 2 persons when moving in the same or adjacent rooms.
- Before moving the unit, make sure to secure or remove any object that might fall off.
- When lifting the unit, use both hands and bend your knees, not your backs.
- When transporting the unit to places far away, lower the unit to the lowest height and protect and secure it to avoid damage in transit.
- Shall any part of the unit become defective during the warranty period, replacement parts might be available to you at no charge. Please refer to the last pages on this manual.
- The warranty does not extend to regular wear and tear, nor the manufacturer assumes liability for damages or consequences due to accidents, incorrect assembly, negligence, improper use, modifications, or not heeding the above warnings.



- Do not dispose of the electrical components in the same bin with regular household wastes. Please check with your city offices for collection services and proper disposal of those items.
- The tabletop and some of the frame pieces are made of materials that can be recycled. Please check with your city offices for collection and recycling services.



## TECHNI MOBILI DESK WARRANTY

### DESKS/LAPTOP CARTS/FILE CABINETS: LIMITED 5-YEAR WARRANTY

RTA Products, LLC warrants to the Original Purchaser who acquired a new product from RTA Products or its authorized resellers that this product will be free from defects in its workmanship and materials, under normal use and service conditions, as described herein. "Defects" as used in this warranty, is defined as any imperfections that impair the use of the furniture or product. RTA Products LLC will replace any defective part, at its discretion, and without charge to the original purchaser other than the freight from the end consumer to RTA Products.

Replacement parts can only be supplied if parts are available. Items out of production may be unavailable. This warranty will be effective for the applicable time period beginning the date of purchase on your original sales receipt. RTA product's obligation under this warranty is limited to repairing or replacing products or parts as provided herein. This product has been designed for and is intended for office and home-office use only. This warranty is Original Purchaser's sole remedy for product defects, and this warranty does not extend to any product, or damage to any product, caused by or attributed to abuse or misuse, products used for commercial or rental purposes, use modifications of, or attachments to the product, and products or parts not used, maintained, or extended hereunder is in lieu of any and all other warranties, express or implied, including without limitations any implied warranty or merchantability or of fitness for a particular purpose. Please note, all desks made with PVC Laminate surface should not be exposed to direct sunlight, as it may damage the material. Damage of this nature is not covered under this warranty.

RTA Products will not be responsible for indirect, special, incidental or consequential damages. This warranty is limited to merchandise purchased in the Continental United States, excludes AK, HI and PR. Some States do not allow the exclusion or limitation of incidental or consequential damages, so the above limitations or exclusions may not apply to you. This warranty gives you specific legal rights. You may also have other rights that may vary from state to state.

RTA Products will advise you of the procedure to follow in making warranty claims. The following are the procedures for warranty claims:

- a. Call us Monday – Friday, from 9am-5pm (Eastern Time) at (866) 782-5520 to explain the defect and give your name, address and phone number. Please have ready the model number of our product, date and place of purchase. You can also write to us by e-mail to [warranty@rtaproducts.com](mailto:warranty@rtaproducts.com) and include the same information.
- b. If we determine that replacement will remedy the situation, and in order to determine the extent or the cause of the defect, purchaser will need to send the part in question at purchaser's expense. Once we receive the part, we will examine it and determine whether the claim is valid (or not), and then proceed to send the replacement. We will ship the replacement at our expense.

# FOR SEVERAL HELP OPTIONS INCLUDING REPLACEMENT PARTS ORDERS

---

VISIT: [WWW.TECHNIMOBILI.COM](http://WWW.TECHNIMOBILI.COM)



CLICK ON SUPPORT TAB



Scan QR Code to order replacement parts

OR EMAIL US: [SUPPORT@RTAPRODUCTS.COM](mailto:SUPPORT@RTAPRODUCTS.COM)