

MODEL RTA-3520

ASSEMBLY INSTRUCTIONS

REV-5-OL-7868-0224

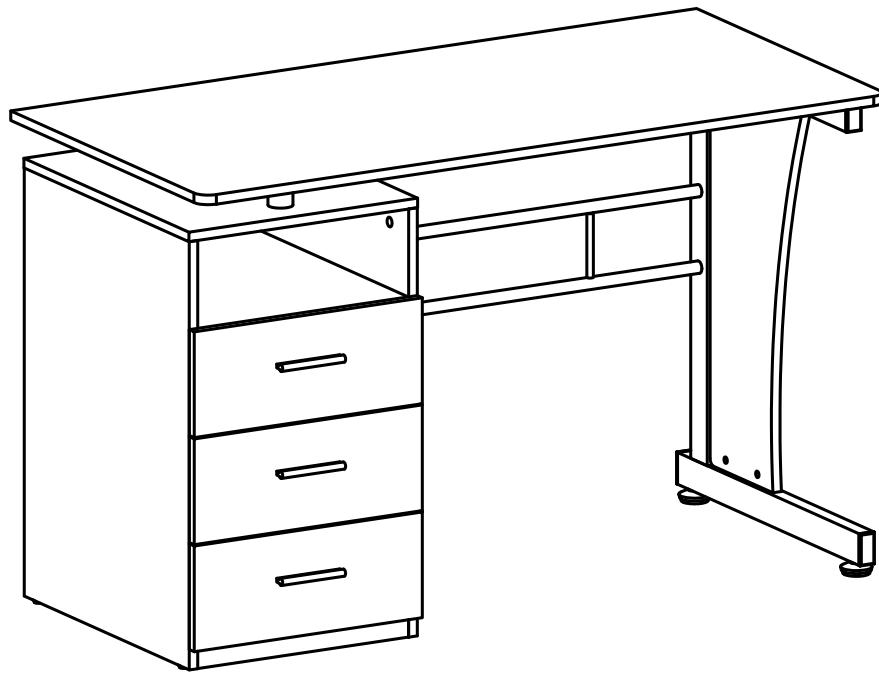

Thank you for purchasing our product



MAIN PARTS LIST

1 Left panel
x1

2 Middle panel
x1

3 Glide studs
x2

4 Cabinet top panel
x1

5 Cabinet shelf panel
x1

6 Bottom panel
x1

7 Back panel
x1

8 Bottom skirt panel
x1

9 Right metal leg
x1

10 Right panel
x1

11 Back metal structure
x1

12 Drawer sliders, SET of 4 pcs for each drawer:
3 sets

- 2 "Flat", right and left for inside the cabinet
- 2 "L" shaped, right and left for the drawers

"Flat": go inside the cabinet "L" shape: go on drawers

13 Desktop
x1

14 Support tube
x2

15 Handle
x3

16 Drawer left panel
x3





17 Drawer right panel
x3



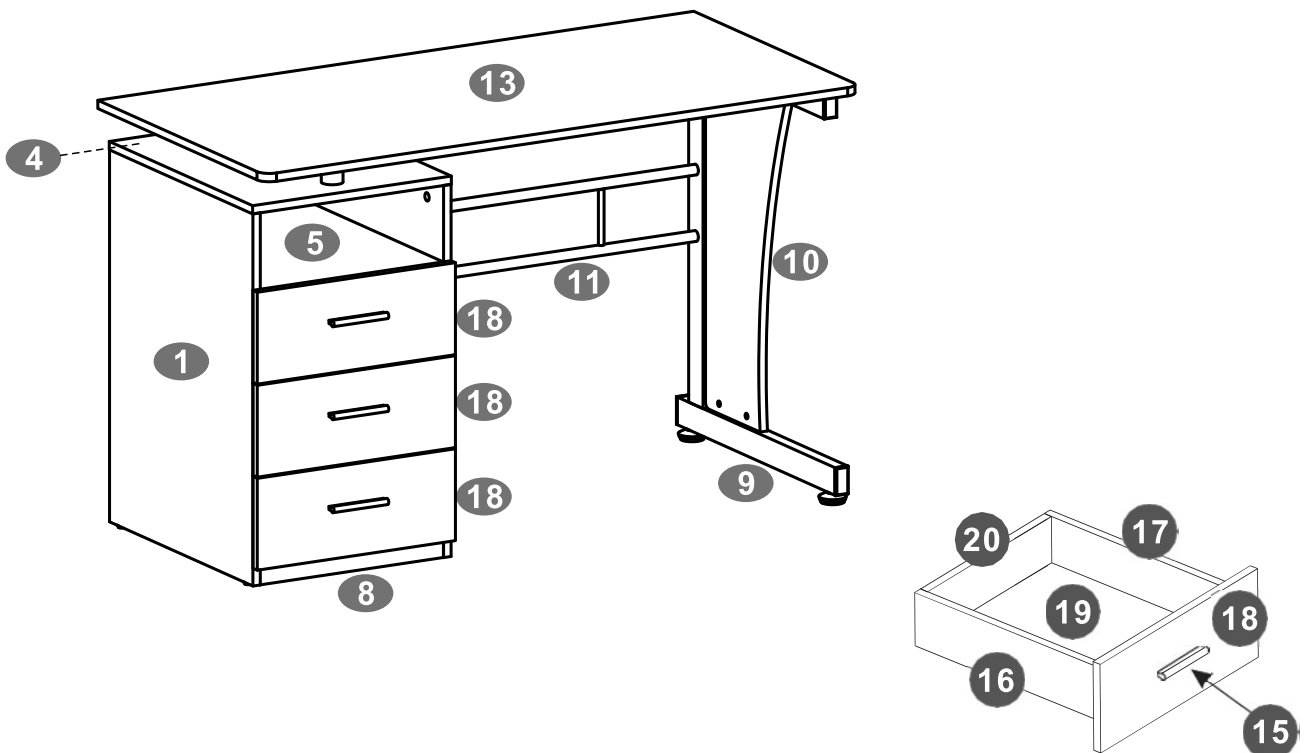

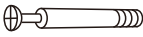
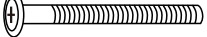
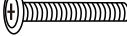
18 Drawer front panel
x3

19 Drawer bottom panel
x3

20 Drawer back panel
x3

MAIN PARTS LAYOUT (FOR REFERENCE):

LIST OF HARDWARE, SCREWS AND FITTINGS

PART	QTY	ITEM	
A	24	M3x15	
B	26	M6x40	
C	4	M6x75	
D	4	M6x35	
E	2	M6x25	
F	6	M4x20	
G	2	Ø40mm Plastic washer	

PART	QTY	ITEM	
H	8	M4x14	
I	2	M6x60	
J	12	M4x35	
	1	Screwdriver	

BEFORE YOU START THE ASSEMBLY, PLEASE READ THE FOLLOWING TIPS AND WARNINGS.

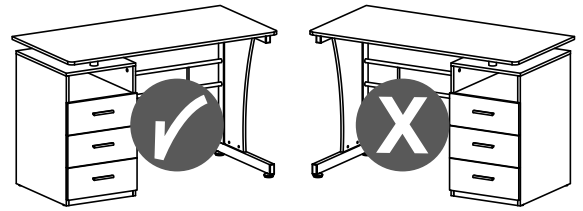
- The product is not reversible, it assembles **ONLY** as shown in the front page, with the drawers on the **RIGHT** side. The drawers cannot install on the **LEFT** side.



- Do not discard this manual or any of the packaging material until the unit is completely assembled.
- Please read the assembly instructions thoroughly and follow step by step.



- The assembly might require of 2 persons for certain steps. Before you start the installation, make sure there is someone else nearby to help you.



- Make sure you understand which hardware will be used on each step. Using the wrong size of screw, bolt or pin might strip the threads or cause damage to the part in which it is being used.

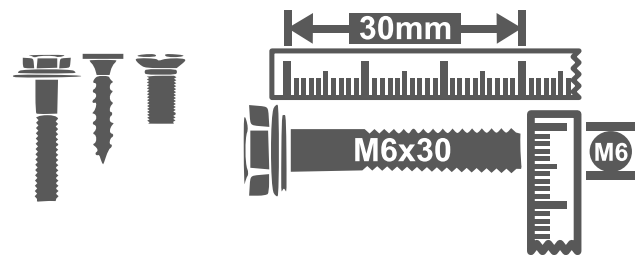

- To avoid misalignments, always leave the screws loosely and do not tighten them until all the pieces are positioned correctly.
- Do not overtighten or force the screws as they might break, strip, damage the threads of the holes, or get stuck inside the parts.

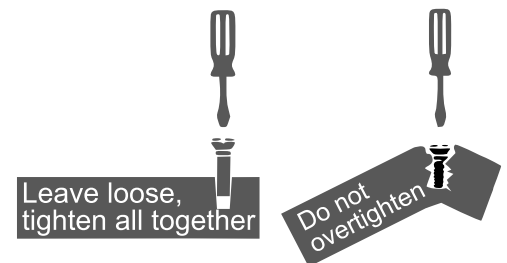

- If the hole seems to small for the screw, make sure you are using the correct size of screw and/or that you are installing it in the correct hole.



- Sometimes on the wood panels the laminate or material might be covering the hole partially or entirely, if there is no visible hole or if it looks too small, pass and press the tip of your finger over the area to feel its indentation, and carefully pierce the laminate to uncover the hole underneath.

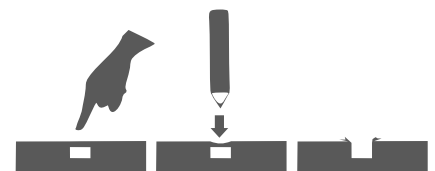

- Please be kind to our planet, when done with the assembly, recycle any of the packaging materials that is accepted by your city or recycling service.



Thank you!



THE ASSEMBLY STEPS START ON NEXT PAGE

CAM BOLT AND CAM LOCK TUTORIAL

THE INSTRUCTIONS BELOW
ARE NOT ACTUAL ASSEMBLY STEPS

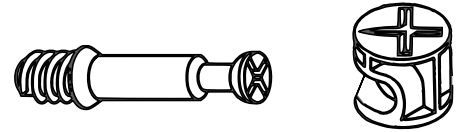

This unit uses cam bolts and locks (also known as mini fixes). If you are not familiar with this kind of hardware, the below is a tutorial that explains how to use them on the steps where they are required.

1. Screw the bolt into the indicated hole on the panel indicated in the assembly step.

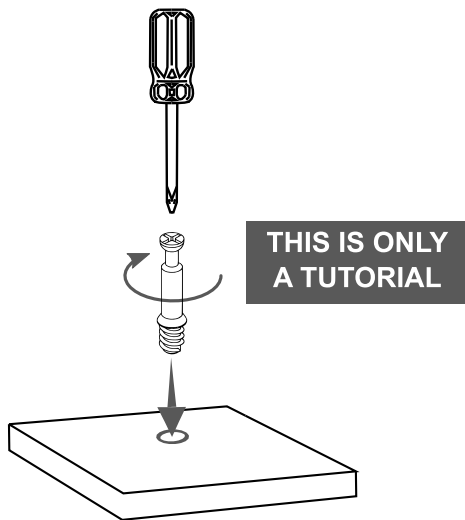

2. Join the other panel (with the big hole) to the panel with the bolt. If it comes with the cam locks already pre-installed, make sure to align them to receive the bolt's head (refer to point 3). There might be a very small gap between the panels which is normal.

If the cam locks come pre-installed, make sure they are aligned (see point 3).

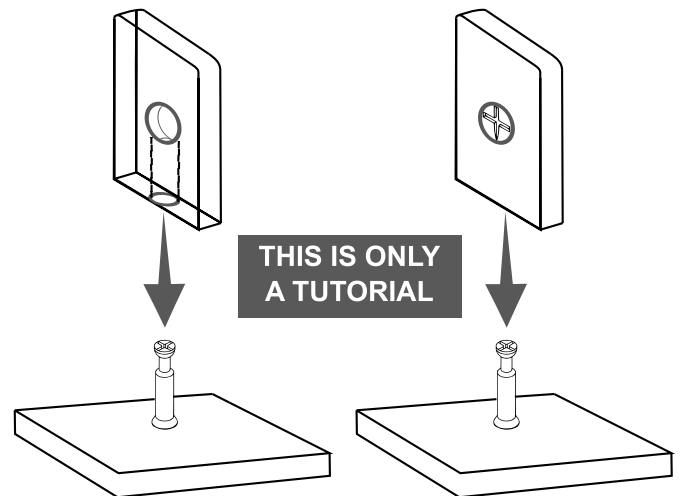

3. Insert the cam lock on the panel with the big hole making sure it goes aligned to receive the bolt's head.

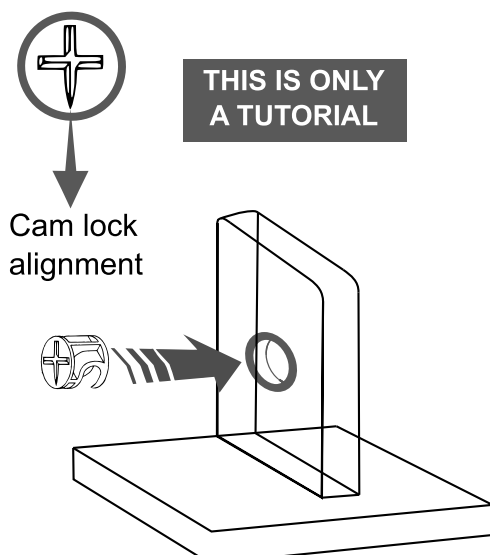

4. Use a Phillips screwdriver to turn the cam lock clockwise. This will lock the panels together and also will close any gaps.

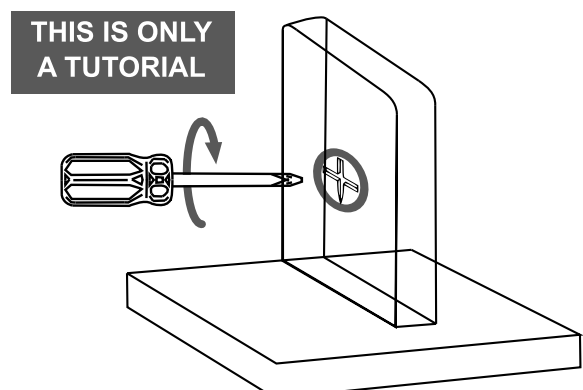

ASSEMBLY STEPS

STEP 1

Grab all the sets of drawer sliders **12** (total 12 pcs) and separate them into 2 groups according to their shape:

- The "Flat" ones will be used on the next step.
- The "L Shaped" will be used until step **16**, set them aside.

12 ("Flat" Right, x3)

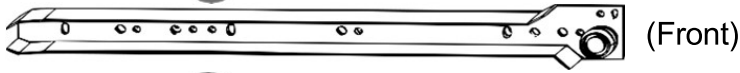

12 ("Flat" Left, x3)

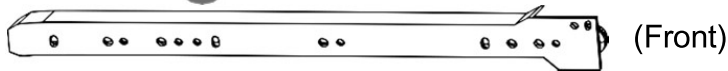

The "Flat" ones will be used on step **2**.

12 ("L" Right, x3)

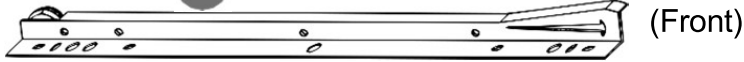

12 ("L" Left, x3)



The "L-Shaped" will be used on step **16**, set them aside.

STEP 2

Hardware:

A



12 Pcs

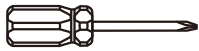

Scan QR Code to view video

Assemble the "Flat" sliders **12** to the side panels **1** and **2** with screws **A**. Please note:

- The sliders attach at the front on the 3th hole.
- The wheel is at the front, and faces down with 2 empty holes above the wheel.

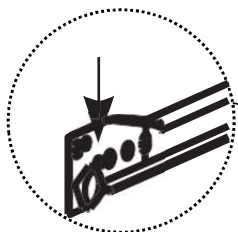
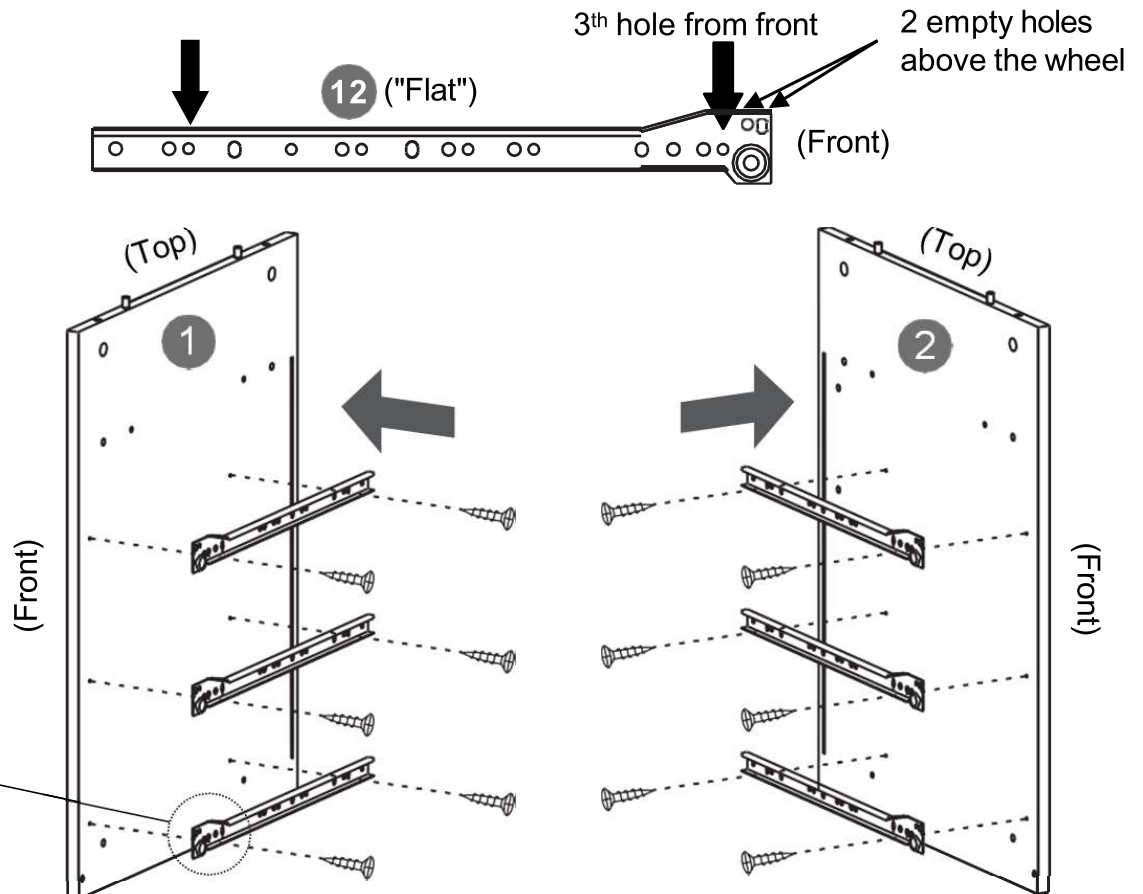

STEP 3

Hardware:

B

M6x40
Bolt5
Pcs

- Attach the bolts **B** to panel **1** into the indicated holes.
- Assemble the shelf **5** to panel **1** at the top as explained in page **5**. Note that the surface with the groove faces towards the bottom. The groove will be located at the back.
- Join panel **8** to panel **6**, then assemble both panels to panel **1** at the bottom as explained in page **5**. Note that on **6** the surface with the groove faces towards the top.

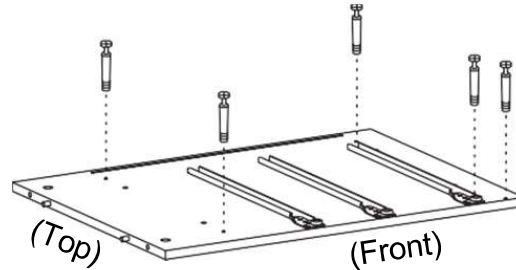
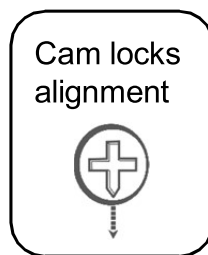
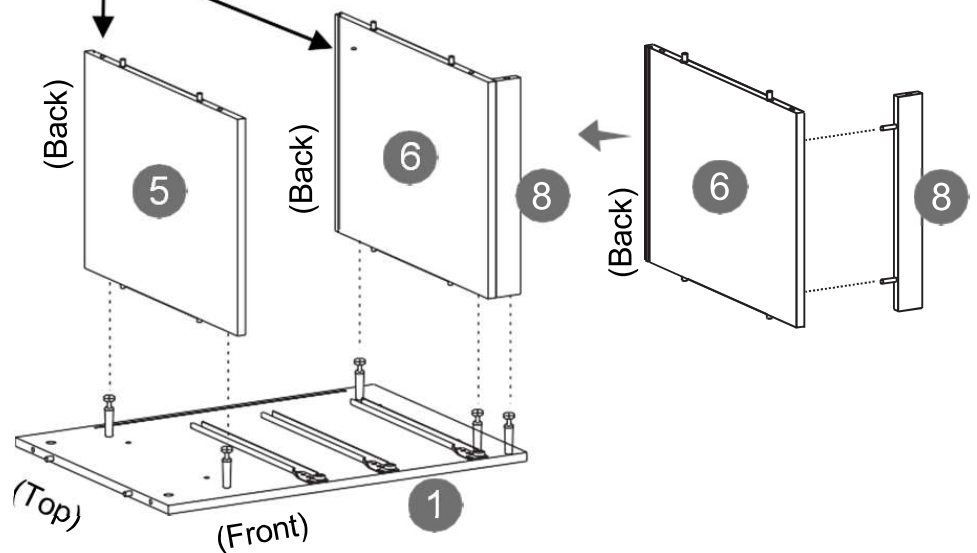
Grooves facing
each otherCam locks
alignment

STEP 4

Slide the back panel **7** through the grooves of panels **5** and **6**, and into the groove of panel **1**.

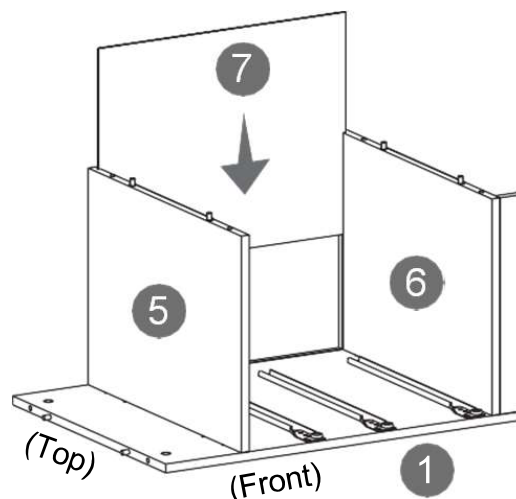

STEP 5

Hardware:

B

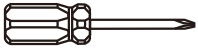
M6x40
Bolt5
Pcs

- Attach the bolts **B** to panel **2** into the indicated holes.
- Assemble panel **2** to panels **5**, **6** and **8** as explained in page 5.

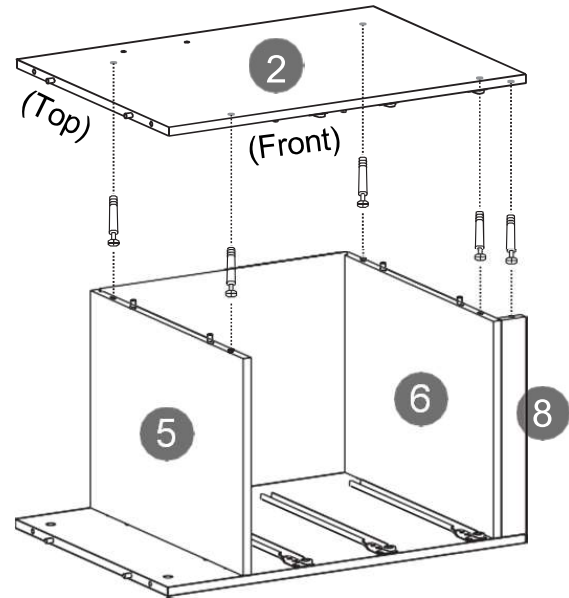
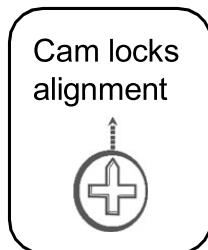
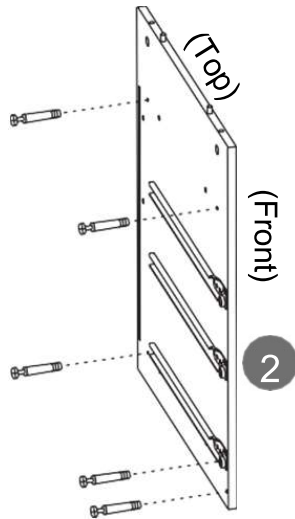

STEP 6

Hardware:

B

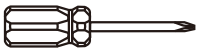
M6x40
Bolt4
Pcs

- Bring the cabinet upright.
- Attach the bolts **B** to the bottom surface of panel **4**.
- Assemble panel **4** to panels **1** and **2** as explained in page 5.

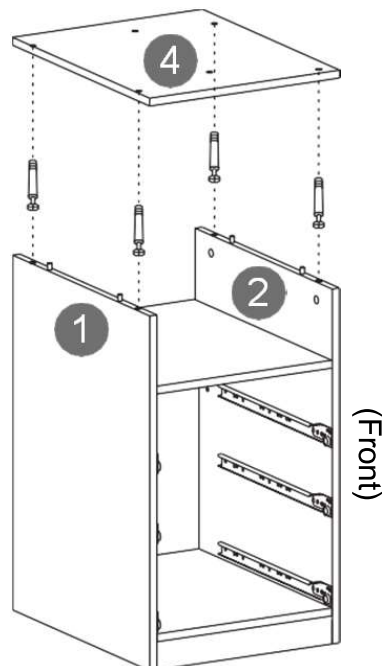
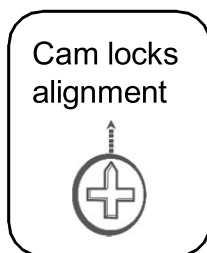

STEP 7

Hardware:

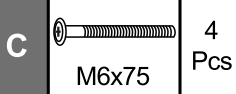

Scan QR Code to view video

- On the right panel **10**, check and make sure the inserts are aligned to receive the screws: The groove on the inserts must run vertically. If the insert are crooked, use a flat head screwdriver to align them.
- Assemble panel **10** to the metal leg **9** with screws **C** from above and underneath as shown.

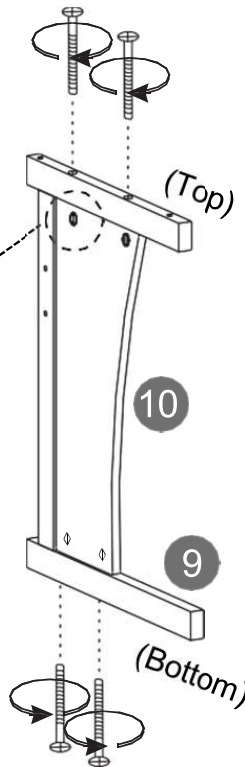

If the inserts on the panel are crooked, the screws won't go in; turn them with a screwdriver to re-align them.

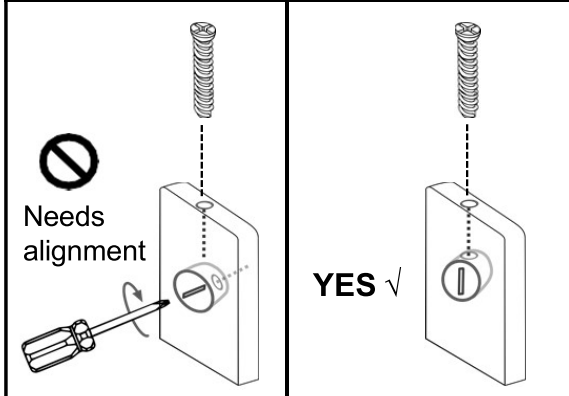

STEP 8

Screw the glide studs **3** into the bottom holes of the leg **9**.

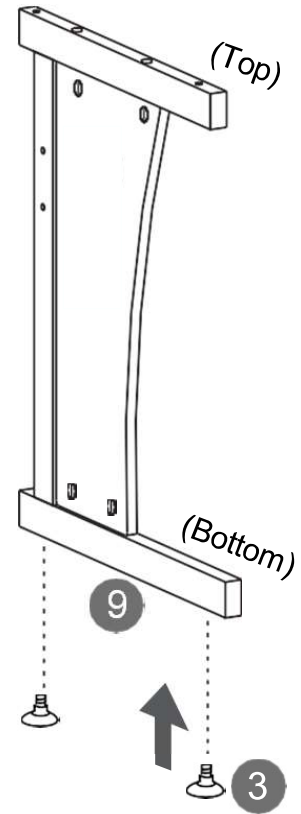

STEP 9

Hardware:

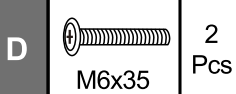

- Assemble the back structure **11** to the middle panel **2** with screws **E** from inside the cabinet.
- Assemble the leg **9** to the back structure **11** with screws **D**.

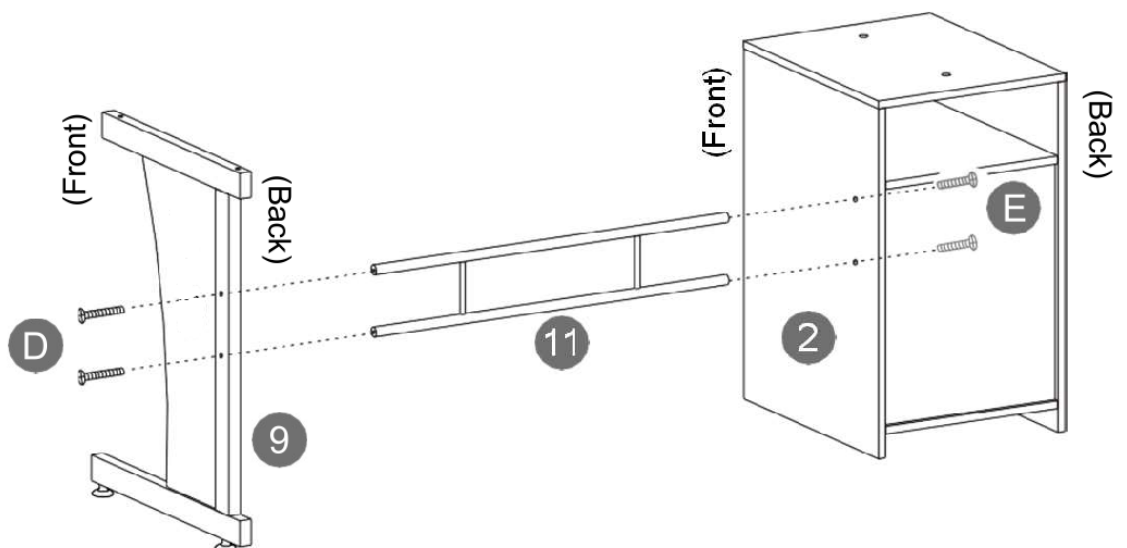

STEP 10

Hardware:

H

8
Pcs

Assemble the support tubes **14** to the tabletop **13** with screws **H**.

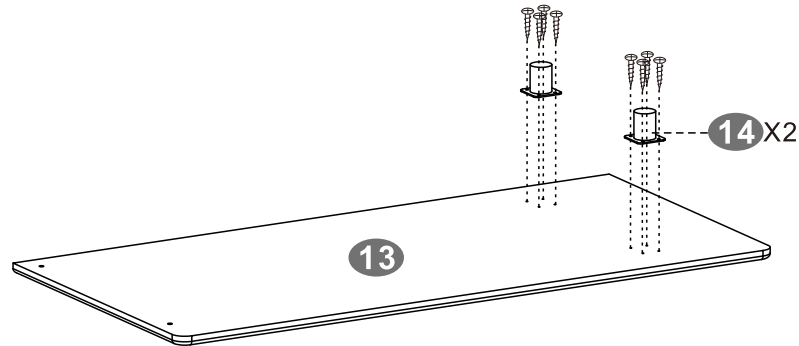

STEP 11

Hardware:

D

2
Pcs

I

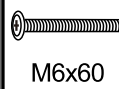
2
Pcs

G

Plastic
washer2
Pcs

- Place the plastic washers **G** over the holes on the cabinet top panel **4**.
- With the help of another person, place the tabletop **13** over the cabinet and leg, making the holes from the tubes **14** coincide with the holes on panel **4** and the washers **G**.
- Assemble the tabletop **13** with screws **D** from underneath. The screws go through panel **4** and the washers, and into the threaded holes of the tubes **14**.
- Assemble the tabletop **13** to the leg **9** with screws **I** from underneath.

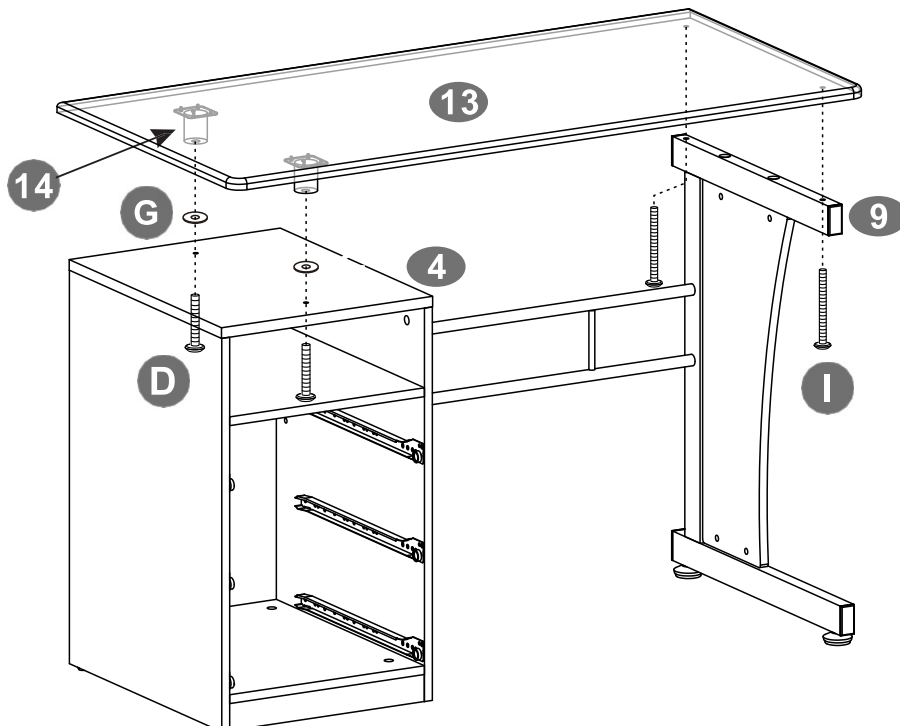

STEP 12

Hardware:

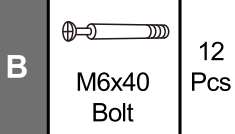

Cam locks alignment



For each of the 3 drawers, assemble the side panels **16** and **17** to the front panel **18** with bolts **B** as explained in page 4.

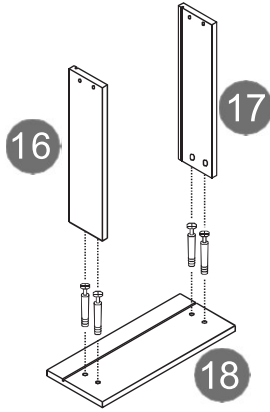

STEP 13

For each of the 3 drawers, slide the bottom panel **19** through the grooves of the side panels and into the front panel as shown.

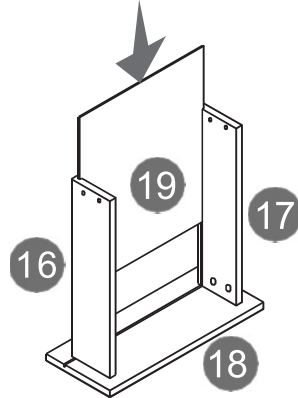

STEP 14

Hardware:

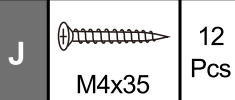

For each of the 3 drawers, assemble the back panel **20** to the side panels **16** and **17** with screws **J**.

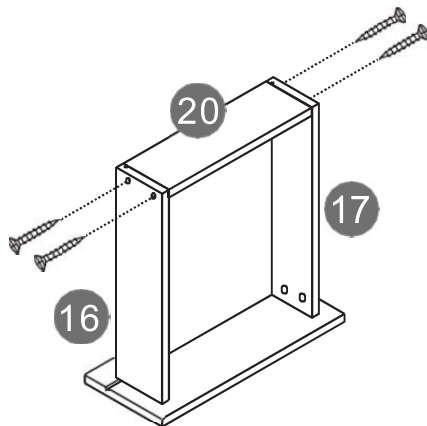

STEP 15

Hardware:

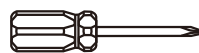

For each of the 3 drawers, assemble the handle **15** to the front panel **18** with screws **F**.

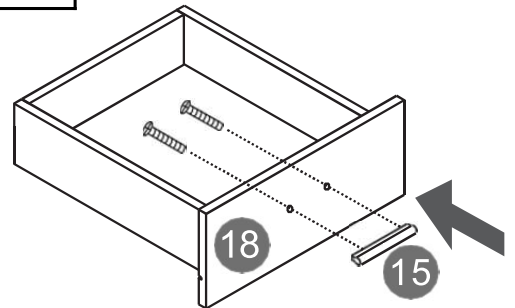

STEP 16

Hardware:

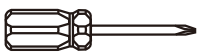

For each of the 3 drawers, flip them upside-down and assemble the "L" sliders **12** with screws **A**, making sure the wheel goes towards the back, and that they don't protrude, otherwise, the drawer raises 1" and won't fit in the cabinet.

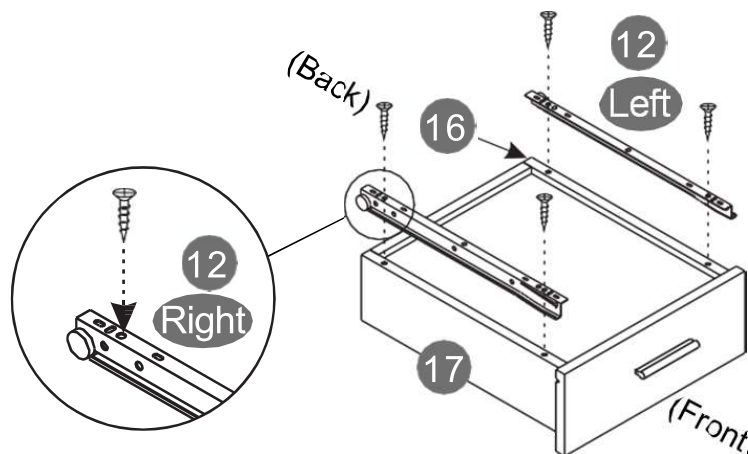

When finished, the sliders should look like this from the back of the drawer:

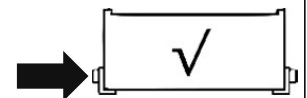

The assembly below is incorrect, it raises 1" and the drawer won't fit:

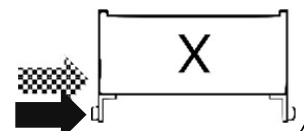

Scan QR Code to view video

STEP 17

- Insert the drawers into the cabinet, starting with the bottom one, then the middle, then the top one. Insert at an angle with their fronts facing down, making sure the wheels from the drawer slide in the middle of the sliders inside the cabinet.
- If the top drawer doesn't fit, and there is a gap at the bottom and/or the top drawer hits the top panel, make sure the drawers are sliding through the cabinet sliders, not on top of them. Also review the assembly done in steps **2** and **16** for the correct assembly of the sliders.

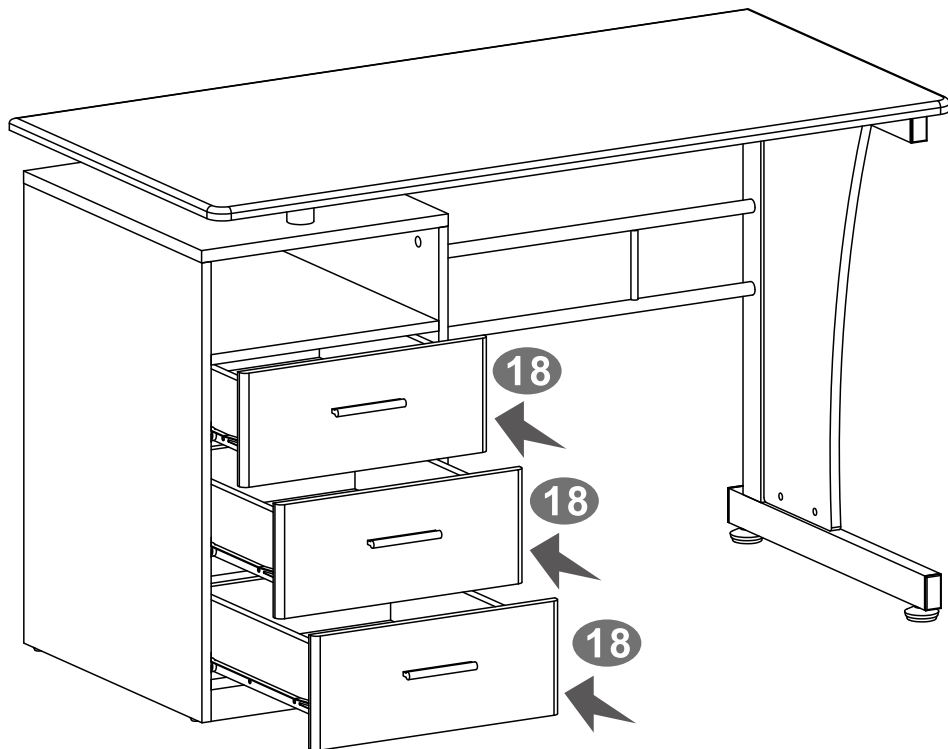

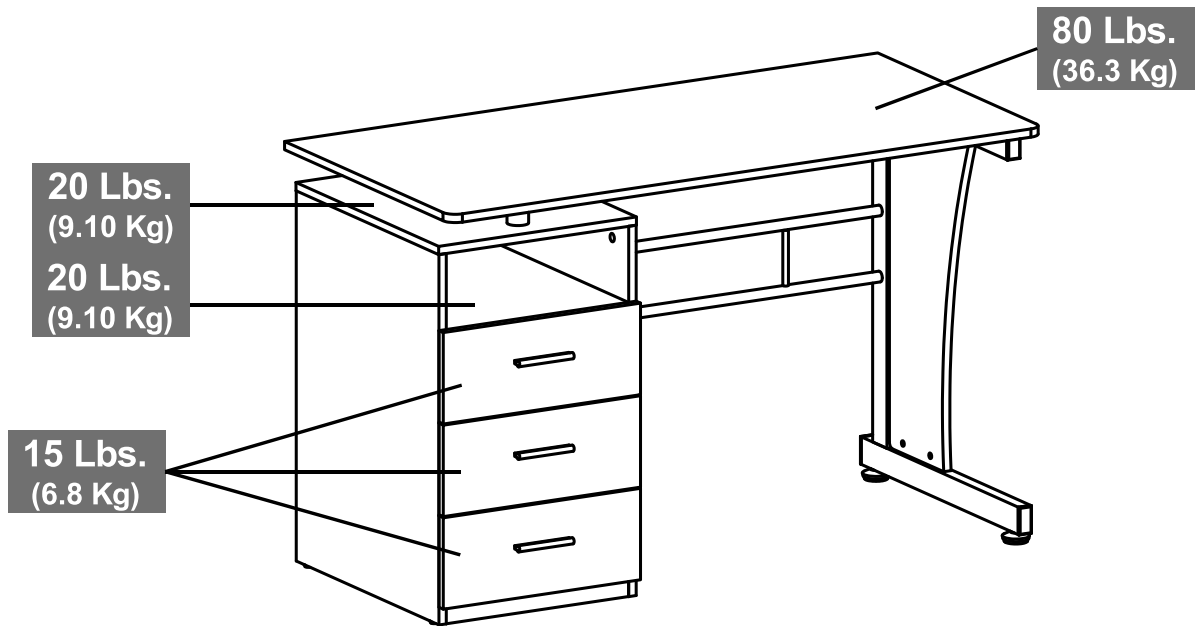
WEIGHT LIMITS**WARNINGS**

- Do not exceed the indicated weight limits.
- Do not expose the surfaces to direct sunlight or to extreme environmental conditions.
- Do not use solvents or abrasive materials to clean the unit.
- Do not sit on the unit or lean against it.
- Do not allow small children to play under or over the unit.
- Do not allow small children to reach inside the drawer without your supervision.
- Do not pull, push or drag the unit to move it for more than 1 feet. The unit must be lifted by at least 2 persons when moving in the same or adjacent rooms.
- Before moving the unit, make sure to secure or remove any object that is heavy or might fall off.
- Lift grabbing the frame, not the tabletop.
- When lifting the unit, use both hands and bend your knees, not your backs.
- Do not use the product if screws are loose or missing, or if you notice damaged parts.
- The warranty does not extend to regular wear and tear, nor the manufacturer assumes liability for damages or consequences due to accidents, incorrect assembly, negligence, improper use, modifications, or not heeding the above warnings.

CARE AND MAINTENANCE

- Clean the surfaces preferable with a clean cloth damped in a solution of mild soap and water, then dry with a clean towel.
- If you decide to use a cleaning agent, test first on an area hidden from view such as underneath the tabletop.
- Every 4 months, inspect the unit completely and make sure that all screws are tighten.
- When transporting the unit to places far away, protect and secure the unit to avoid damage in transit.

TECHNI MOBILI WARRANTY**DESKS/LAPTOP CARTS/FILE CABINETS: LIMITED 5-YEAR WARRANTY**

RTA Products, LLC warrants to the Original Purchaser who acquired a new product from RTA Products or its authorized resellers that this product will be free from defects in its workmanship and materials, under normal use and service conditions, as described herein. "Defects" as used in this warranty, is defined as any imperfections that impair the use of the furniture or product. RTA Products LLC will replace any defective part, at its discretion, and without charge to the original purchaser other than the freight from the end consumer to RTA Products.

Replacement parts can only be supplied if parts are available. Items out of production may be unavailable. This warranty will be effective for the applicable time period beginning the date of purchase on your original sales receipt. RTA product's obligation under this warranty is limited to repairing or replacing products or parts as provided herein. This product has been designed for and is intended for office and home-office use only. This warranty is Original Purchaser's sole remedy for product defects, and this warranty does not extend to any product, or damage to any product, caused by or attributed to abuse or misuse, products used for commercial or rental purposes, use modifications of, or attachments to the product, and products or parts not used, maintained, or extended hereunder is in lieu of any and all other warranties, express or implied, including without limitations any implied warranty or merchantability or of fitness for a particular purpose. Please note, all desks made with PVC Laminate surface should not be exposed to direct sunlight, as it may damage the material. Damage of this nature is not covered under this warranty.

RTA Products will not be responsible for indirect, special, incidental or consequential damages. This warranty is limited to merchandise purchased in the Continental United States, excludes AK, HI and PR. Some States do not allow the exclusion or limitation of incidental or consequential damages, so the above limitations or exclusions may not apply to you. This warranty gives you specific legal rights. You may also have other rights that may vary from state to state.

To file a Claim within the 48 contiguous United States:

Email us to warranty@rtaproducts.com to explain the defect and provide your name, address, phone number, model number of our product, date and place, and proof of purchase. Please provide pictures of the damage or defect. If we determine that a replacement will remedy the situation, and in order to determine the extent or the cause of the defect, purchaser may be requested to send the part in question at purchaser's expense. Once we receive the part, we will examine it and determine whether the claim is valid (or not), and then proceed to send the replacement. We will ship the replacement at our expense.

Replacement Parts for International Customers & AK-HI-PR orders:

RTA Products will replace the part free of charge, while **the customer is responsible for shipping costs plus any International local taxes or duties.**