

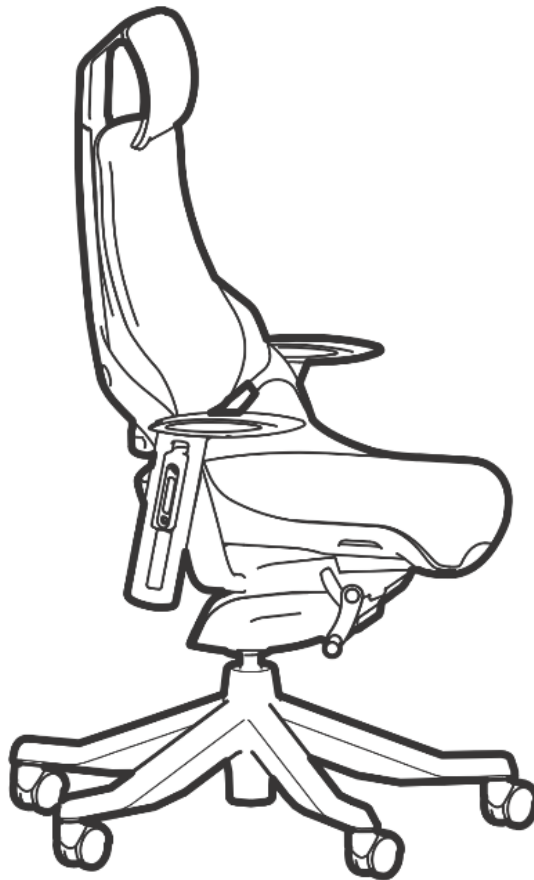

MODEL RTA-1818C

ASSEMBLY INSTRUCTIONS



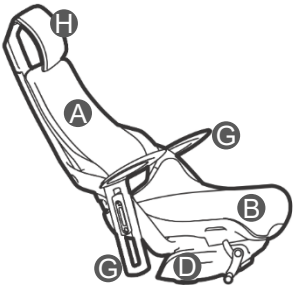

Thank you for purchasing our product.

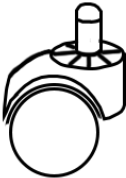

MAIN PARTS LIST

<p>B x1 Seat (piece B) with Backrest (Piece A), Armrests (Pieces G), Mechanism (piece D) and Headrest (Piece H) pre-assembled to it</p> 	<p>C x1 5-Leg star base</p> 
<p>E x1 Hydraulic gas lift</p> 	<p>F x5 Casters</p> 

BEFORE YOU START THE ASSEMBLY:

<p>1 Do a quick inventory to make sure the package contains all the parts listed in the assembly instructions.</p> 	<p>2 Missing, damaged and defective parts can be replaced at no cost to you. Please refer to the last page in this manual.</p> 
<p>3 The replacement parts service is limited to the continental United States. If you reside in Alaska, Hawaii, Puerto Rico, U.S. Territories or other countries, please contact the supplier from where the unit was purchased.</p> 	<p>4 If during assembly you find an issue or need clarification, please contact our Customer Service for assistance. Please refer to the last page in this manual.</p> 

ASSEMBLY STEPS

STEP 1

Insert the casters **F** into the legs of the base **C** using pressure.

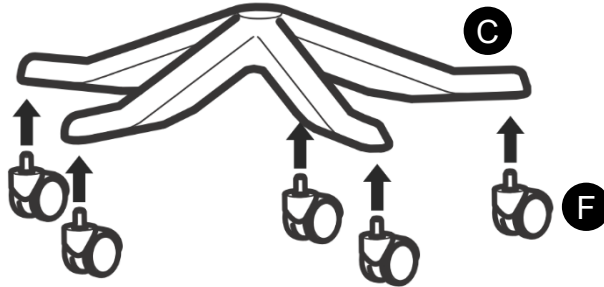

STEP 2

Place the gas lift **E** in the middle of the base **C**.

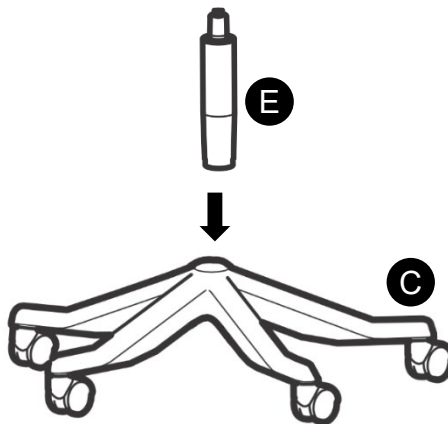

STEP 3

2 PERSONS
REQUIRED



With the help of another person, place the seat **B** over the base parts making sure the tip of the gas lift **E** enters into the hole of the mechanism **D** that is under the seat.

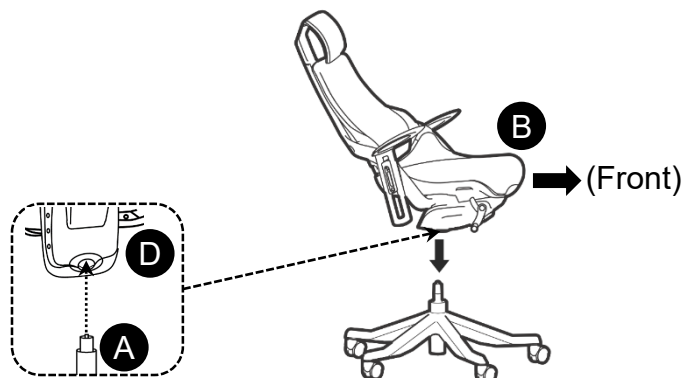

CHAIR'S FUNCTIONS

ADJUSTABLE HEIGHT



Scan QR Code to view this function

Pull UP the lever that is on the RIGHT side of the seat; The chair goes down while sitting on it, or up if you lift your body.

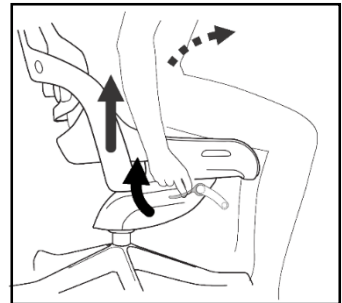
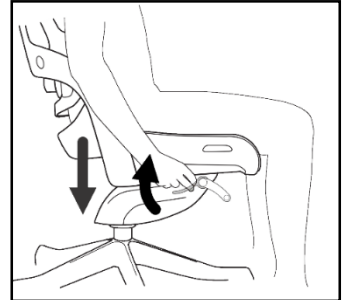
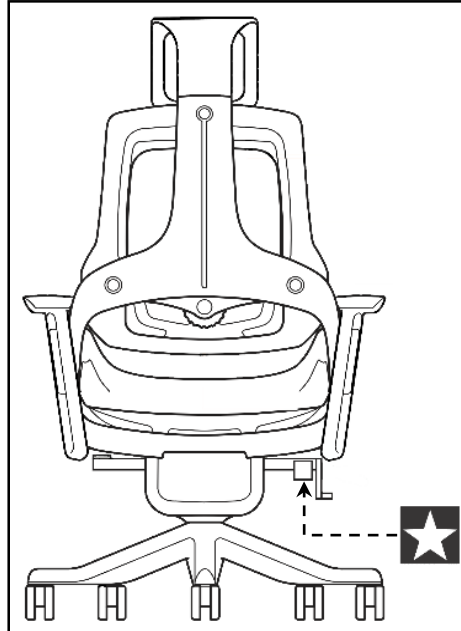

BACKREST RECLINING



Scan QR Code to view this function

Pull UP the lever that is on the LEFT side of the seat and recline your back just a little bit; this action UNLOCKS the reclining function of the backrest, so it reclines freely. To LOCK into any desired angle, just push the lever DOWN. To UNLOCK the function and bring to the default upright position, re-adjust the angle, or keep it reclining freely, pull the lever UP again and recline your back a little bit as before.

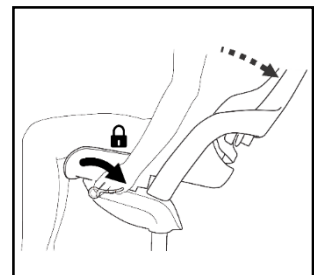
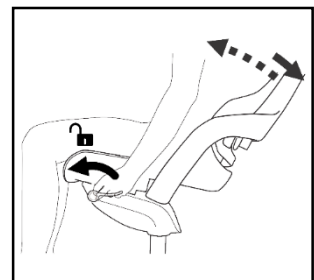
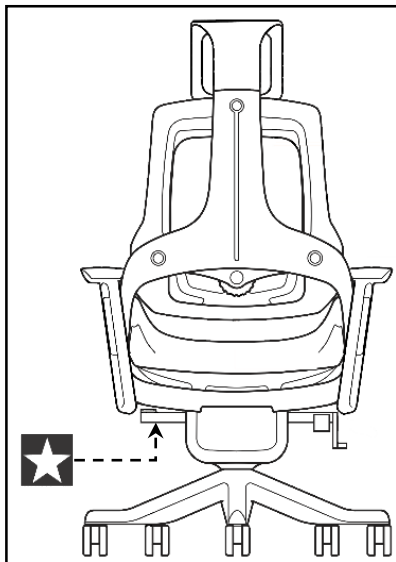

TILT LOCK



Scan QR Code to view this function

Turn the handle that is on the **RIGHT** side of the seat **FORWARD** (Clockwise) to increase the reclining tension for the backrest. Turn the same handle **BACKWARDS** (Counter-clockwise) to reduce the reclining tension for the backrest. With less tension, the reclining feels easier.

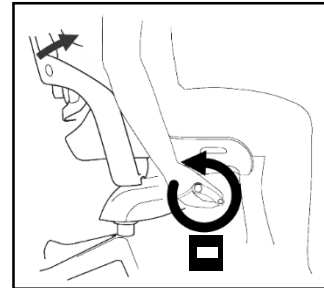
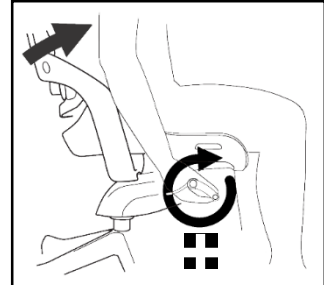
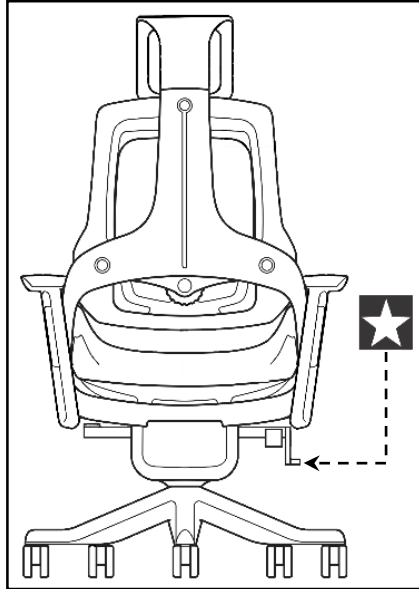

BACKREST HEIGHT



Scan QR Code to view this function

Push the top of the backrest **FORWARD**, and move it **UP** or **DOWN**, then release it when the desired height has been reached.

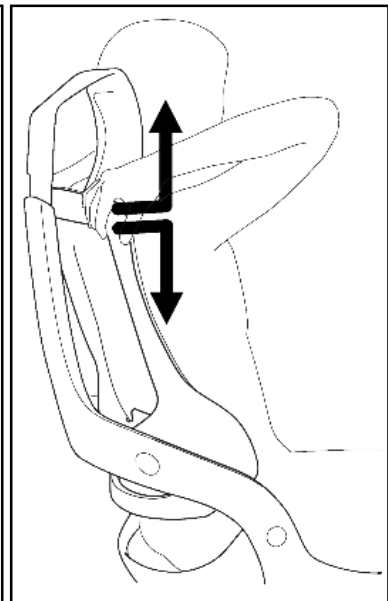
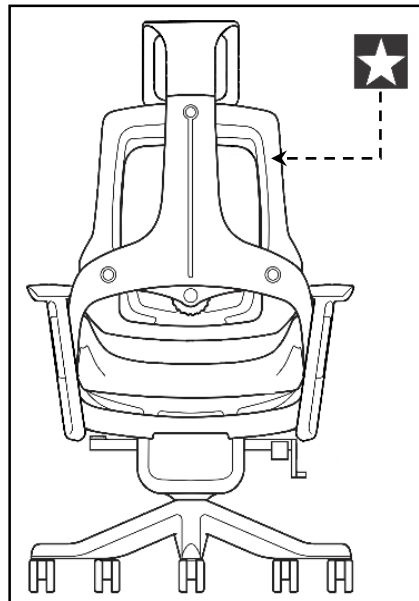

LUMBAR SUPPORT

Scan QR Code to
view this function

Turn the knob that is on the **BACK** side of the backrest to adjust the depth of the lumbar support:

- Turn clockwise to move it forward.
- Turn counter-clockwise to move it backwards.

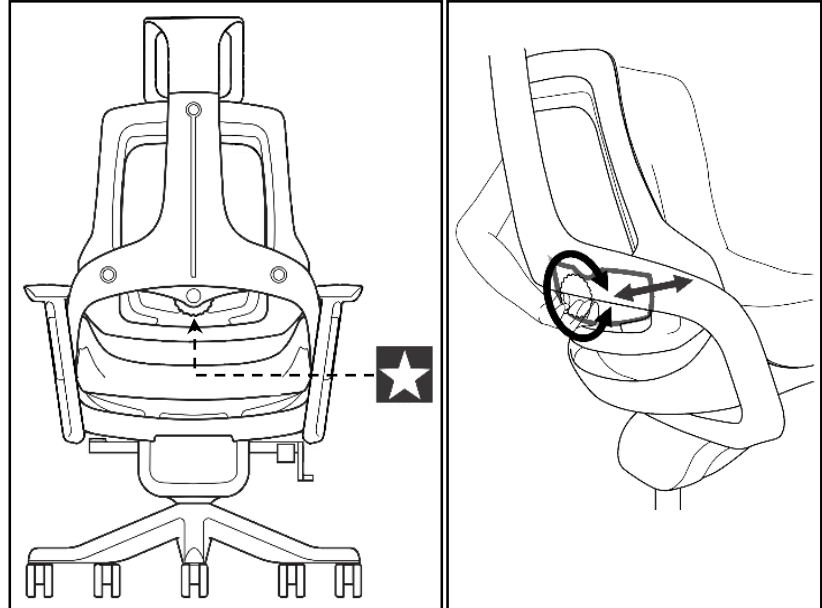
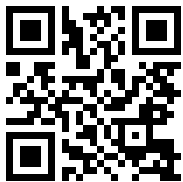
**ADJUSTABLE
HEADREST**

Scan QR Code to
view this function

Pull the headrest **FORWARD**, and move it **UP** or **DOWN**, then release it when the desired height has been reached.

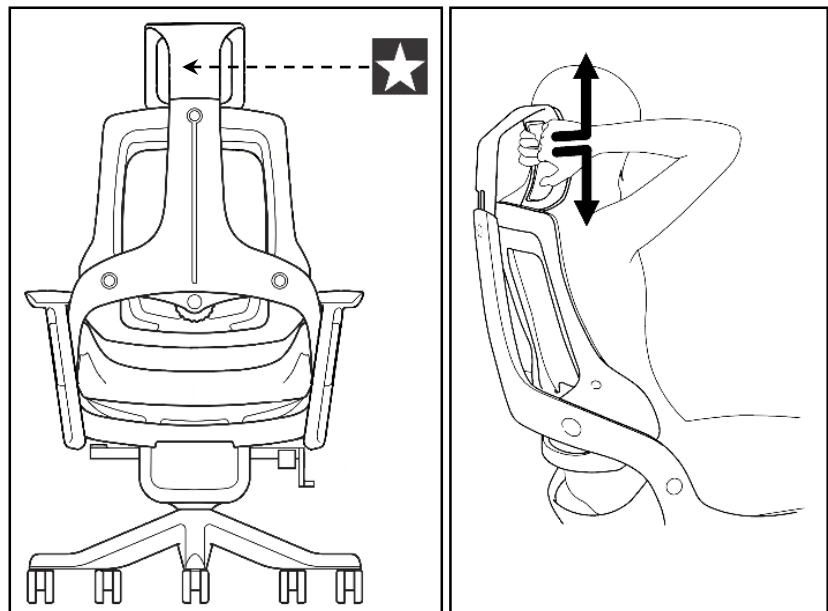

**ADJUSTABLE
ARMRESTS**



Scan QR Code to view this function

Pull the armrest **BACKWARDS**, and move it **UP** or **DOWN**, then release it when the desired height has been reached.

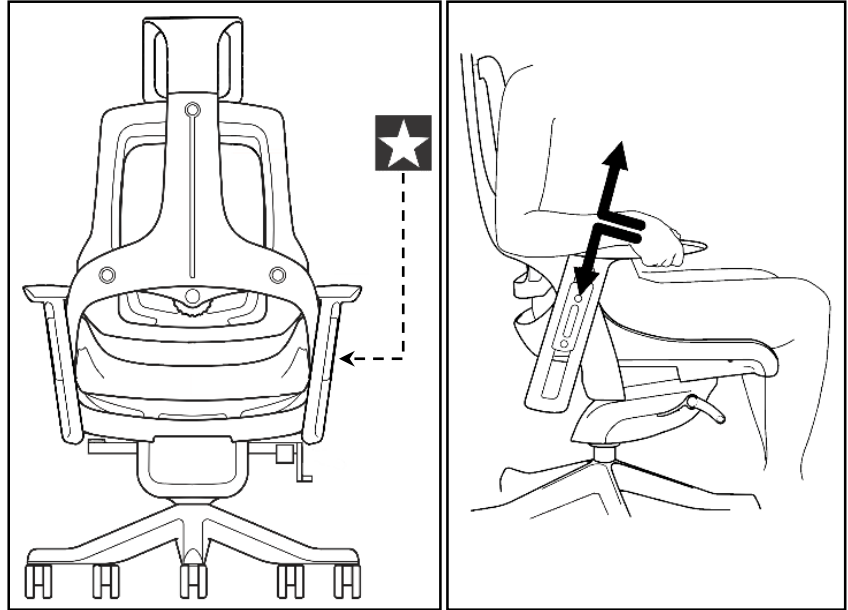

**ADJUSTABLE
ARMREST**



Scan QR Code to view this function

Swivel the armrests pads **IN** or **OUT** according to your preference.

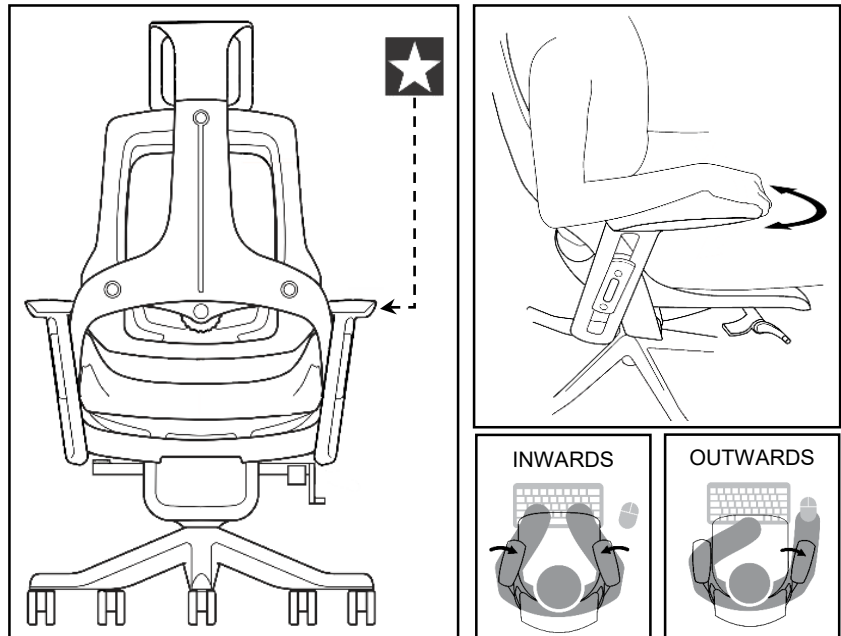

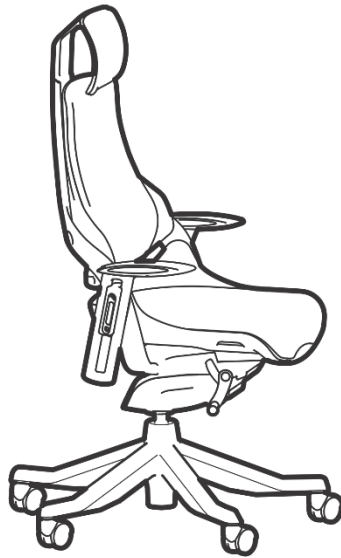
WARNINGS

- Do not exceed the indicated weight limit.
- Do not stand up on the chair or use it as ladder.
- Only one person at a time can sit on the chair.
- Do not use the chair if parts are damaged or if screws are loose or missing.
- Do not sit near the edge of the seat to avoid going beyond your balance point and falling off the chair, and always sit properly.
- If small children are sitting on the chair, please keep close observation on them.
- Do not allow small children to play with the chair.
- Not paying attention to these warnings could result in injuries.

CARE AND MAINTENANCE

- To clean the chair it is recommended to use a soft cloth lightly dampened in a solution of smooth soap and water, then dry with a clean towel.
- Do not use solvents or abrasive materials to clean any part of the chair.
- Before applying a cleaning agent, test on a small hidden area of the chair, like underneath the seat.
- Do not expose the product to direct sunlight or to extreme environmental conditions.
- Every 4 months, inspect the chair completely and make sure that all screws are tightened.

P.8	RTA-1818C	P.8
-----	-----------	-----

TECHNI MOBILI CHAIR WARRANTY
TASK/KID'S CHAIR: 1-YEAR WARRANTY
EXECUTIVE/MANAGER CHAIR: 2-YEAR WARRANTY

- 1.TA Products, LLC has warranted the Techni Mobili office chairs to the original purchaser who acquired a new product from RTA Products or its authorized resellers of the product against defects in material or workmanship.
- 2.This warranty is expressly limited to the repair or replacement (at its option) of defective chair components or materials that fails under normal use as a result of a defect in materials or workmanship. This warranty is limited to merchandise purchased in the Continental United States. No assembly labor is included. The word "defects" as used in this warranty, is defined as imperfections that impair the utility of the product.
- 3.This warranty applies under conditions of normal use, but does not apply to defects that result from intentional damage, negligence, unreasonable use or exposure.
- 4.Liability for consequential damages is excluded to the extent exclusion is permitted by law. This warranty gives you specific legal rights, and you may have other rights that vary from State to State.
- 5.RTA Products does not warrant: a) natural variations in character marks b) changes in surface finishes due to aging or exposure to light c) marks, scars, or wrinkles occurring naturally in leather d) failure resulting from normal wear and tear e) the matching of colors, grains, or textures of natural materials f) the colorfastness or the matching of textiles, including an exact match to cuttings or to swatch cards g) damage, marking, or staining of veneer surfaces due to contact with rubber or similar compounds, damage from sharp objects or imprinting from writing instruments, or prolonged exposure to direct sunlight h) we do not warrant products that are exposed to extreme environmental conditions or that have been subject to improper storage.
- 6.RTA Products shall not be liable for loss of time, inconvenience, commercial loss, or incidental or consequential damages.
- 7.Any modification to the original product voids the warranty. We do not warrant the performance of the product when used in combination with other than original products.
- 8.This product has been designed for and is intended for office and home-office use only. This warranty is Original Purchaser's sole remedy for product defects, and this warranty does not extend to any product, or damage to any product, caused by or attributed to abuse or misuse, products used for commercial or rental purposes, use modifications of, or attachments to the product, and products or parts not used, maintained, or extended hereunder is in lieu of any and all other warranties, express or implied, including without limitations any implied warranty or merchantability or of fitness for a particular purpose.
- 9.Report any defects to RTA Products, LLC together with your sales receipt or other proof of purchase. If the chair is defective within the terms of the warranty, RTA Products, LLC will furnish a replacement chair (at its option) at no cost of equal or similar value and design.
- 10.RTA Products will advise you of the procedure to follow in making warranty claims. The following are the procedures for warranty claims:
 - a) Call us Monday – Friday, from 9am-5pm (Eastern Time) at (866) 782-5520 to explain the defect and give your name, address and phone number. Please have ready the model number of our product, date and place of purchase. You can also write to us by e-mail to warranty@rtaproducts.com and include the same information.
 - b) If we determine that replacement will remedy the situation, and in order to determine the extent or the cause of the defect, purchaser will need to send the part in question at purchaser's expense. Once we receive the part, we will examine it and determine whether the claim is valid (or not), and then proceed to send the replacement. We will ship the replacement at our expense.

FOR SEVERAL HELP OPTIONS INCLUDING REPLACEMENT PARTS ORDERS

VISIT: WWW.TECHNIMOBILI.COM



CLICK ON SUPPORT TAB



Scan QR Code to order replacement parts

OR EMAIL US: SUPPORT@RTAPRODUCTS.COM