

# 4 FT FOLDING TABLE MODEL RTA-04FLT

# 6 FT FOLDING TABLE MODEL RTA-06FLT



## Owner's Manual

REV.EB-7367-0623

Thank you for purchasing our product

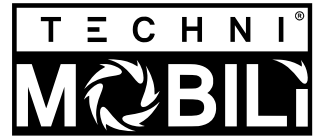

SEE OTHER SIDE FOR DIMENSIONS, WARNINGS AND CARE

### INSTRUCTIONS FOR SETTING UP AND FOLDING THE TABLE:

1. Open and unfold completely.

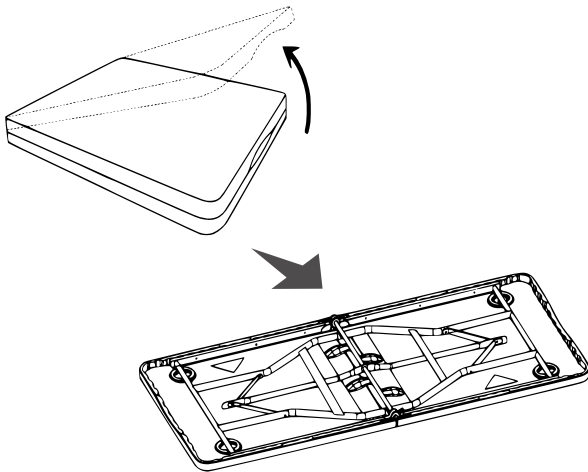

2. **FIRST** press the switch in the middle to **LOCK**, **THEN** unfold the legs one at a time making sure the Y-shaped supports are fully stretched.

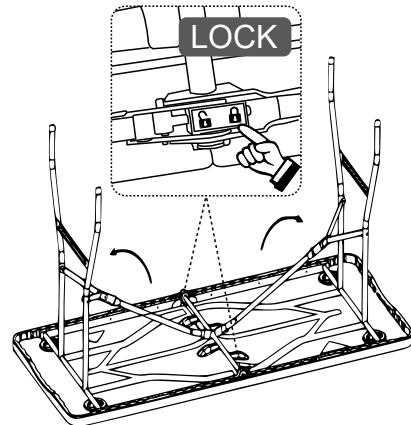

3. Flip the table upright and move the rings to the center of the Y-shaped supports to secure the legs.

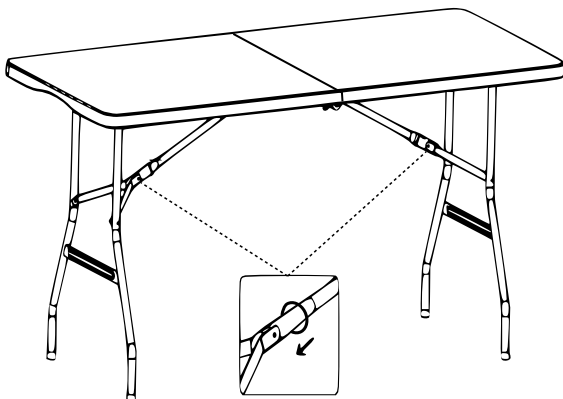

To store the table, **FIRST** flip it upside-down, **THEN** move the rings away from the center of the Y-shaped supports and fold the legs. **LASTLY**, press the switch to **UNLOCK** and fold the table ready for storage.

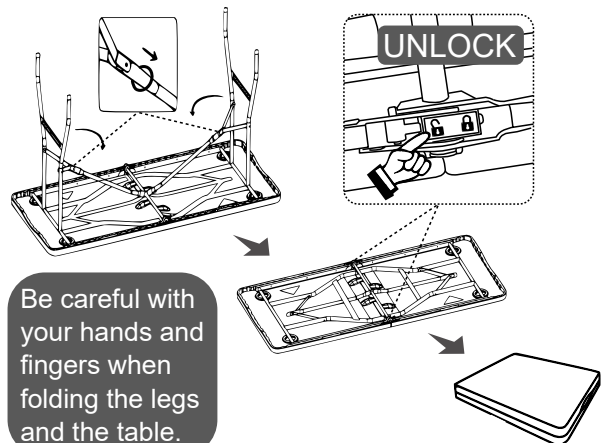

Customer Service: [support@rtaproducts.com](mailto:support@rtaproducts.com)

# 4 FT FOLDING TABLE MODEL RTA-04FLT

# 6 FT FOLDING TABLE MODEL RTA-06FLT



## Owner's Manual

REV.EB-7367-0623

Thank you for purchasing our product

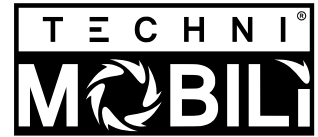

SEE OTHER SIDE FOR INSTRUCTIONS FOR FOLDING-UNFOLDING

### DIMENSIONS AND WEIGHT CAPACITIES:

#### RTA-04FLT

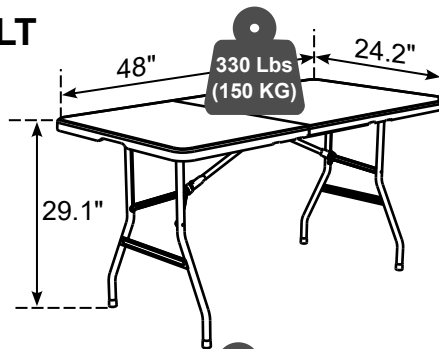

#### RTA-06FLT

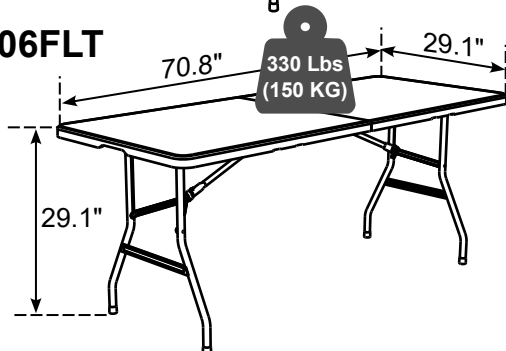

### WARNINGS:

- Do not exceed the indicated weight limit.
- Be careful when folding down the legs or the table to avoid hand injuries.
- Do not leave objects hanging over the edge of the table.
- If you have to move the table while objects are still on it, remove or secure those that could tip over or fall off.
- Do not use if the product appears to be damaged or defective.
- The manufacturer does not assume liability for consequences due to accidents, overloading, negligence, improper use or modifications.

### CARE AND MAINTENANCE:

- Do not expose the product to extreme environmental conditions.
- Please note that the product is prone to discoloration and other forms of regular wear and tear from continue use as well as exposure to the elements and direct sunlight.
- To clean the table it is recommended to use a soft cloth lightly damped in a solution of smooth soap and water, then dry with a clean towel.
- Do not use solvents or abrasive materials.
- Before using a cleaning agent, test on a small hidden area, like underneath.
- Inspect the product periodically for loose screws, broken/detached rivets, broken welding and for any other defects that might become a safety risk.

### STORAGE:

- Please see the other side for instructions on folding the table.
- Fold the table and store in a dry place.
- If you own several of these same tables, do not overstack and secure appropriately.

- DO NOT OVERSTACK
- SECURE APPROPRIATELY.

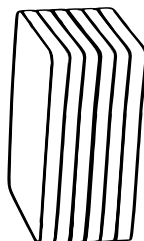
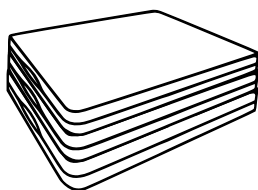

Customer Service: [support@rtaproducts.com](mailto:support@rtaproducts.com)