

ASSEMBLY INSTRUCTIONS FOR CHAIR MODEL RTA-M101

PARTS LIST

(Part number, description, Qty.)

ATTENTION: Before you begin to assemble the product, please make sure that all the parts are included in the package, and inspect them for damages or defects. Also make sure you have all the necessary tools.

A. Backrest, x1

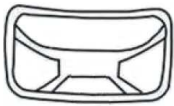

B. Seat, x1



C. Base, x1

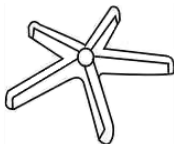

D. Mechanism, x1

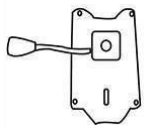

E. Gas Lift, x1



F. Casters, x5



G. Allen Wrench
x1



H. Gas Lift
Covers, x1 Set

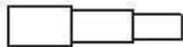

I. Backrest
Support, x1



1. Screw
6*16mm, x4



2. Screw
6*25mm, x2



3. Backrest
cover, x1



4. Knob, x1



5. Screw
8*20mm, x1



ATTENTION:

- ⚠ Follow the instructions step by step.
- ⚠ To avoid misalignments, leave the screws loose and do not tighten them until all are in their respective places.
- ⚠ Do not overtighten or force the screws as they could break, strip, or damage the threads of the holes.
- ⚠ Using the wrong size of screws on a part could result in damage to the screw or the part.

STEP 1

Insert the casters (F) into the legs of the base (C) using pressure, then place the gas lift (E) in the middle of the base, and cover it with (H) as shown.

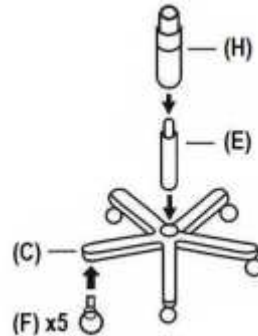

STEP 2

With the seat positioned as shown, assemble the mechanism (D) to the seat (B) using screws (1) as shown. The handle will be located on the RIGHT when the chair is finished.

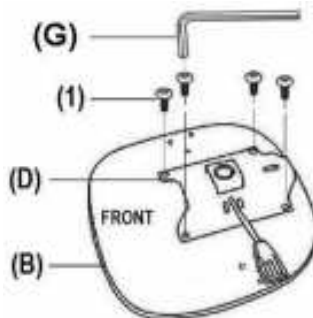

STEP 3

Assemble the support (I) to the backrest (A) using the cover (3) and screws (2) as shown.

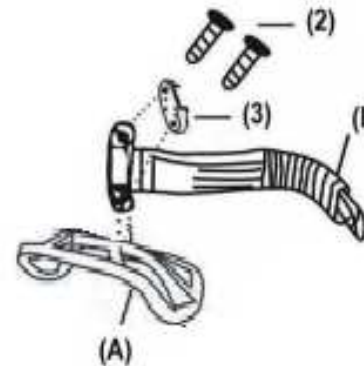

STEP 4

Secure the support (I) to the mechanism using knob (4) and screw (5) as shown.

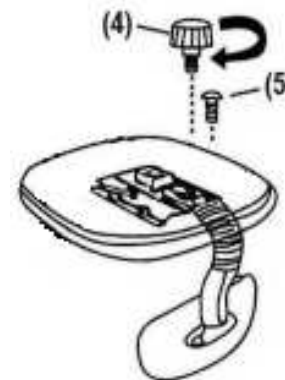

STEP 5

Place the top parts of the chair over the base parts, making sure the tip of the gas lift enters into the hole of the mechanism.



Make sure that all screws are tightened before you sit on the chair for the first time.

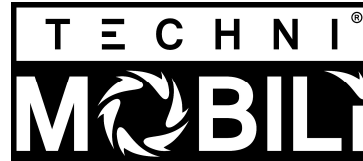

CHAIR'S FUNCTIONS:

- Chair's height function: Pull the lever UP with force. The chair will go down while sitting on it, or up if you lift your body.

WARNINGS:

- Do not stand up on the chair or use it as ladder.
- Use the chair to seat only one person at a time.
- Do not exceed the maximum weight capacity.
- Do not use the chair if parts are damaged or if screws are loose or missing.
- Do not seat near the edge of the seat and always sit properly on the chair to avoid going beyond your balance point and fall off the chair.
- The chair is intended for teenagers and adults. If small children are using the chair, please keep close observation on them.
- Do not allow small children to play with the chair.
- Not paying attention to these warnings could result in severe injuries.

CARE AND MAINTENANCE:

- To clean the chair it is recommended to use a soft cloth lightly damped in a solution of smooth soap and water, then dry with a clean towel.
- Do not use solvents or abrasive materials to clean any part of the chair.
- Before applying a cleaning agent, test on a small hidden area of the chair, like underneath the seat.
- Do not expose the product to direct sunlight or to extreme environmental conditions.
- Every 4 months, inspect the chair completely and make sure that all screws are tighten.