



FRONT RUNNER
VEHICLE OUTFITTERS

DRAWER KIT

JEEP WRANGLER JKU 4-DOOR (2007 – CURRENT)

ENG

SSDS112 / SSST002 / SSJW002

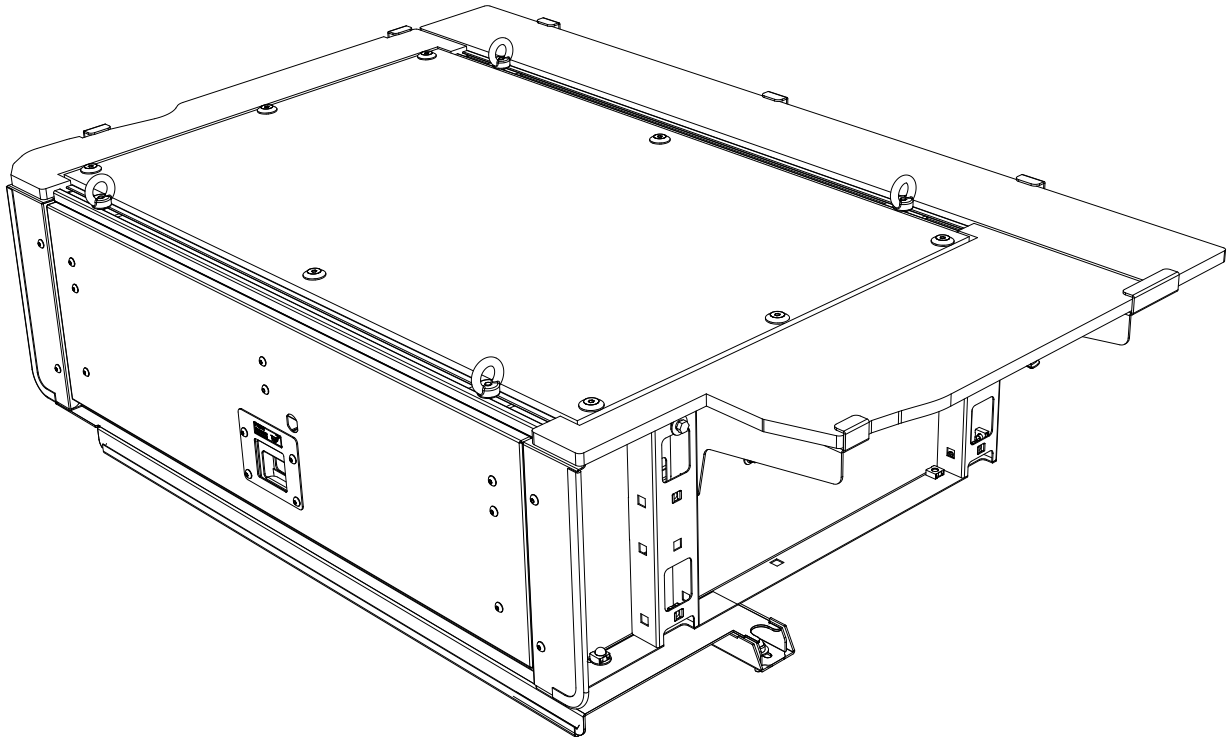

READ ME !

Thank you for purchasing a Front Runner Jeep Wrangler JKU 4-Door Drawer Kit.
Before you start, take a moment to familiarize yourself with this Fitting Instruction and the components received.
Refer to Page 2 for a list of all the components, quantities and tools required.

IMPORTANT WARNING!

IT IS CRITICAL THAT ALL FRONT RUNNER PRODUCTS BE PROPERLY AND SECURELY ASSEMBLED AND ATTACHED TO YOUR VEHICLE.
IMPROPER ATTACHMENT COULD RESULT IN AN AUTOMOBILE ACCIDENT, AND COULD CAUSE SERIOUS BODILY INJURY OR DEATH.
YOU ARE RESPONSIBLE FOR ASSEMBLING AND SECURING ALL FRONT RUNNER PRODUCTS TO YOUR VEHICLE. CHECKING THE ATTACHMENTS PRIOR TO USE, AND PERIODICALLY INSPECTING THE PRODUCTS FOR ADJUSTMENT, WEAR AND DAMAGE.
THEREFORE YOU MUST READ AND UNDERSTAND ALL OF THE INSTRUCTIONS AND PRECAUTIONS SUPPLIED WITH YOUR FRONT RUNNER PRODUCT PRIOR TO INSTALLATION OR USE.
IF YOU DO NOT UNDERSTAND ALL OF THE INSTRUCTIONS AND CAUTIONS, OR IF YOU HAVE NO MECHANICAL EXPERIENCE AND ARE NOT THOROUGHLY FAMILIAR WITH THE INSTALLATION PROCEDURES,
YOU SHOULD HAVE THE PRODUCT INSTALLED BY A PROFESSIONAL INSTALLER OR OTHER QUALIFIED PERSONNEL.

1 GET ORGANIZED

Here is what you are looking at for SSSDR011

IN THE BOX

1	1 X	Drawer System
2	4 X	Turnbuckle
3	4 X	M6 Wing Nut
4	4 X	D-Ring
5	4 X	M6 x 20 Hex Bolt
6	4 X	M6 Spring Washer
7	4 X	M6 x 19 x 1SS Flat Washer
8	4 X	M6 Eye Nut
9	4 X	M6 Stud Plate
10	4 X	Nylon Washer

TOOLS NEEDED



FIGURE 1.1

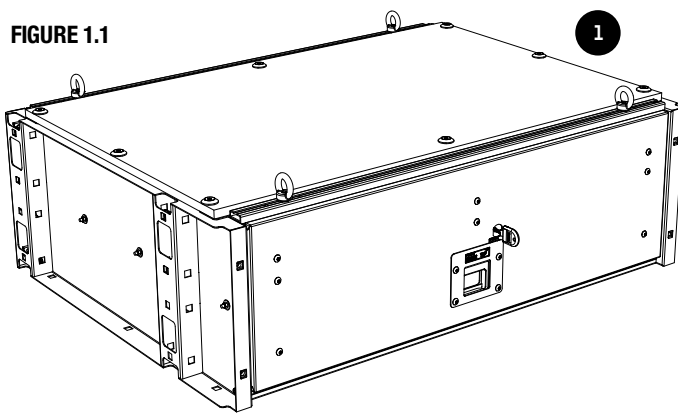
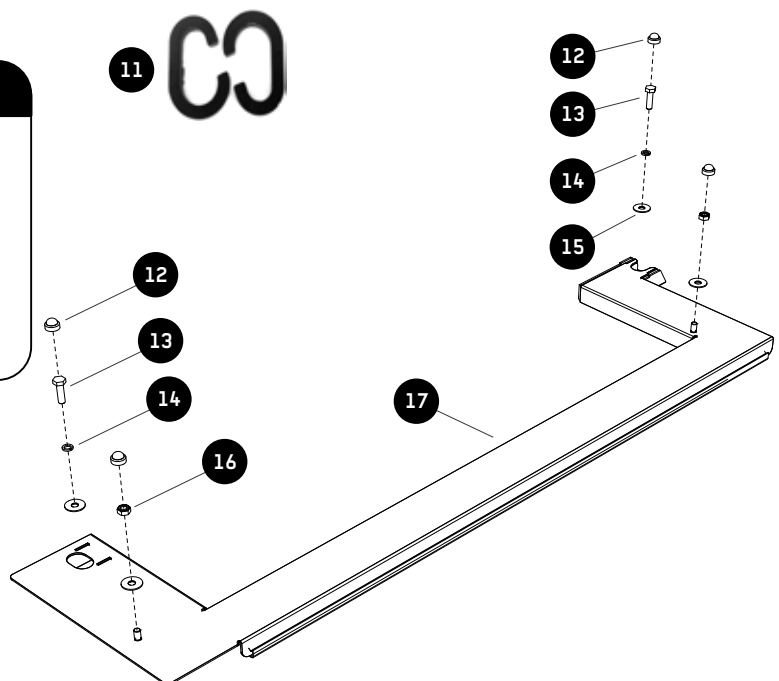

FIGURE 1.2

Here is what you are looking at for SSST002

IN THE BOX

11	2 X	37mm C-Hook
12	4 X	M6 Nut Cap
13	2 X	M6 x 25 Hex Bolt
14	2 X	M6 Spring Washer
15	4 X	M6 x 19 x 1SS Flat Washer
16	2 X	M6 Nyloc Nut
17	1 X	Mounting Plate



1

GET ORGANIZED

Here is what you are looking at for SSDS112

IN THE BOX

18	1 X	Rear Deck
19	1 X	RH Deck
20	1 X	LH Deck
21	1 X	Rear Wing LH
22	1 X	Rear Center Wing
23	1 X	Rear Wing RH
24	1 X	Side Wing RH Rear
25	1 X	Side Wing RH Front
26	2 X	Side Wing LH Front & Rear
27	14 X	M6 x 19 x 1 SS Flat Washer

IN THE BOX

28	14 X	M6 Spring Washer
29	14 X	M6 x 16 Hex Bolt
30	2 X	Pinch Weld 440mm
31	2 X	Front Face 1LH + 1RH
32	4 X	M6 x 12 Button Head

FIGURE 1.3

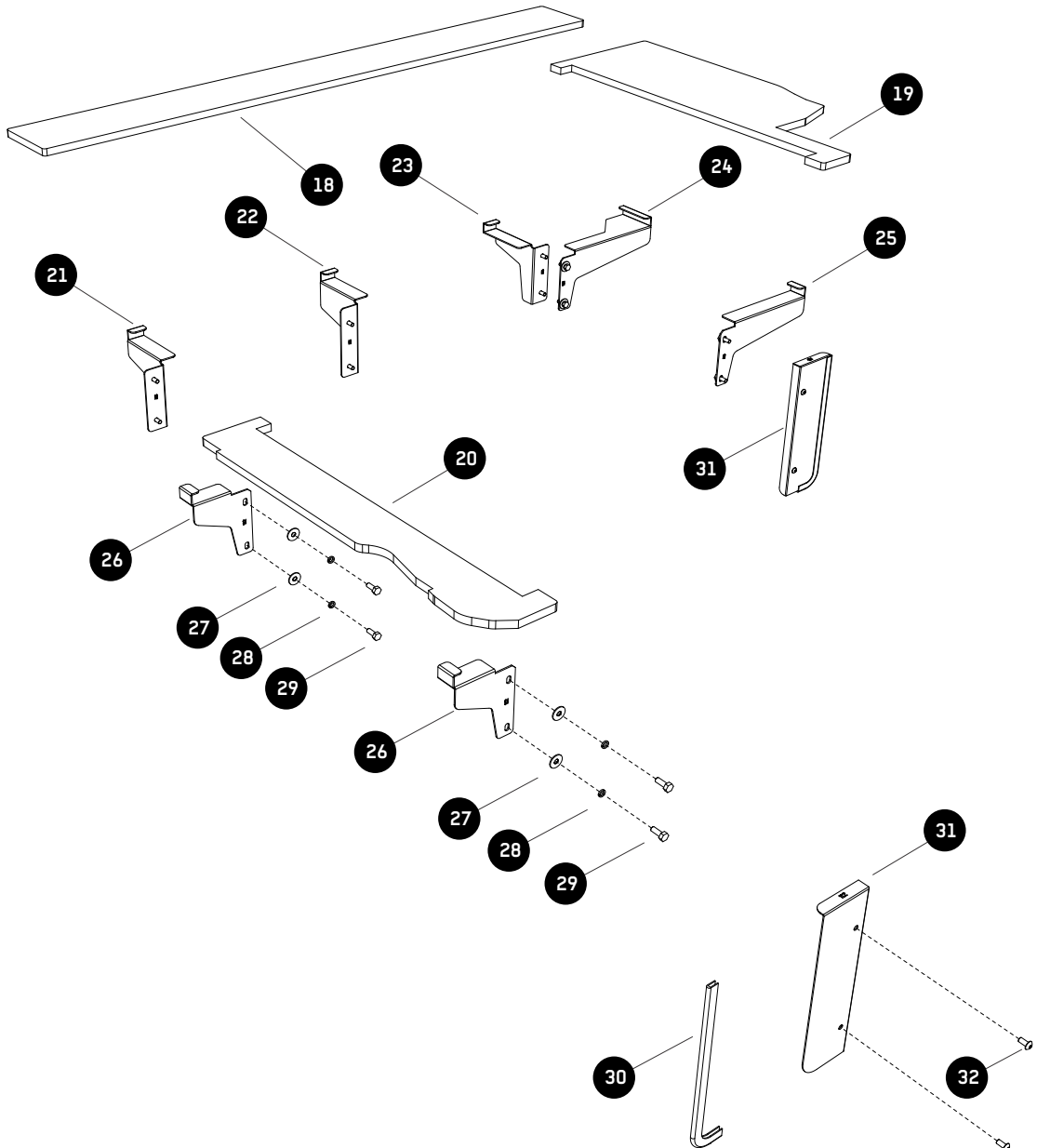

2**PREPARE FOR INSTALLATION**

2.1

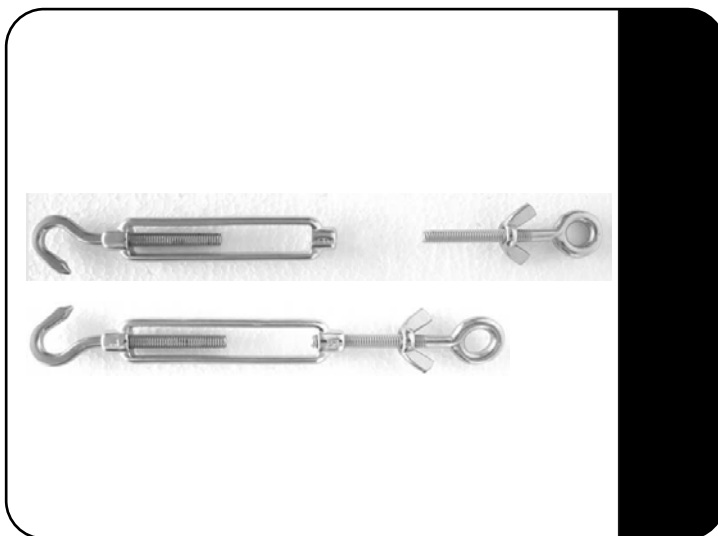

Loosen and remove the eye bolt of the Turnbuckles (Item 2) supplied with SSSDR011, and assemble a M6 Wing Nut (Item 3) as shown. Reassemble the Turnbuckle

2.2



Remove the storage cover from the vehicle. Lift the plastic storage liner and remove the jack and toolkit from the vehicle.

2.3



Loosen and remove the two tie down rings either side of the vehicle as indicated. The threaded mounting points in the vehicle's body will be used to secure the Mounting Plate (Item 12) to the vehicle in Step 3.1.

2**PREPARE FOR INSTALLATION**

2.4



If the two original tie down rings (as indicated by the arrows) have been removed from the vehicle, they need to be refitted. If the original tie down rings have been lost, use two D-rings, two M6x20 Hex Bolts, two M6x19x1ss Flat Washers and two M6 Spring Washers (Items 4, 5, 6 & 7) supplied with SSDR011.

2.5

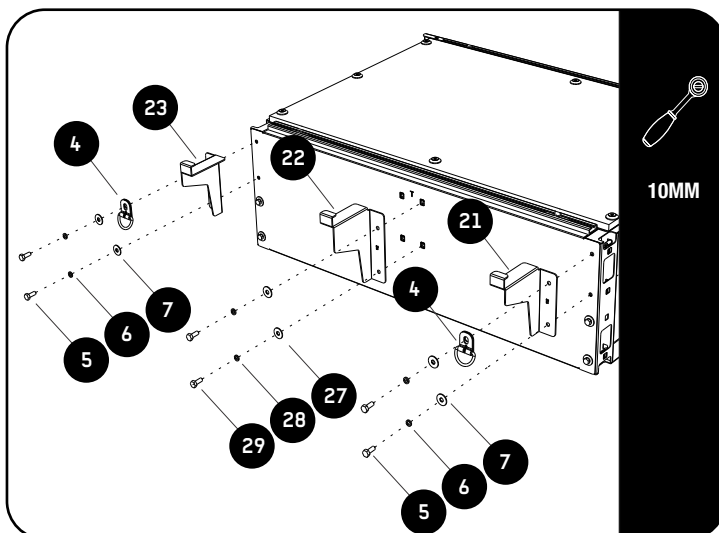

Working at the rear of the drawer system, remove the two top M6 Hex Bolts on both the left and right hand side of the drawer. Secure the Rear LH and RH Wings (Items 21 & 23) together with two D-rings (Item 4) as shown, using M6x20 Hex Bolts, M6 Spring Washers and M6x19x1SS Flat Washers (Items 5, 6 & 7).

Secure the Rear Center Wing (Item 22) using M6x16 Hex Bolt, M6 Spring Washers and M6x19x1SS Flat Washers (Items 27, 28 & 29) as shown.

2.6

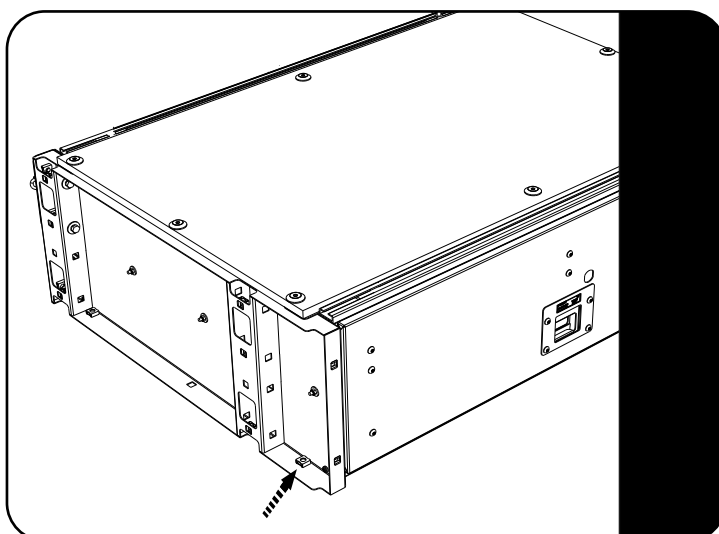

Remove the cage nut shown. The Mounting Plate (Item 17) will be secured through the square hole where you have removed the cage nuts.

3**FIT AND SECURE**

3.1



Place the Mounting Plate (Item 17) into position, lining up the two mounting holes in the plate with the threaded mounting points in the vehicle's body from Step 2.3. Secure the plate to the vehicle using two M6x25 Hex Bolts, two M6 Spring Washers and two M6x19x1SS Flat Washers (Items 13, 14 & 15). Place a M6 Nut Cap (Item 12) over each Hex Bolt.

3.2



Place the Drawer System into the vehicle. The front square holes in the base of the Drawer sit over the studs in the Mounting Plate as shown. Secure the Drawer to the Mounting Plate using two M6 Nyloc Nuts and two M6x19x1SS Flat Washers (Items 15 & 16). Place a M6 Nut Cap (Item 12) over each of the Nyloc Nuts.

3.3

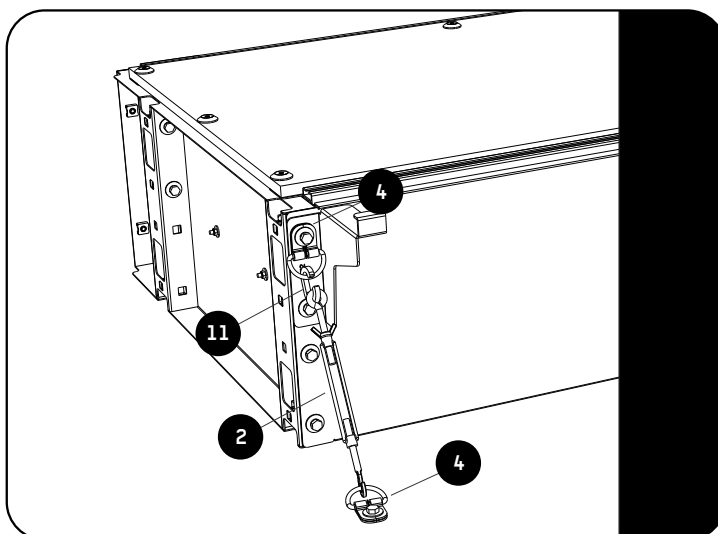

Using the two Turnbuckles from Step 2.1 (Item 2) and the two 37mm C-hooks (Item 11), secure the rear of the Drawer System to the vehicle as shown. Once the rear of the Drawer is secure, tighten the Wing Nuts (Item 3).

3

FIT AND SECURE

3.4

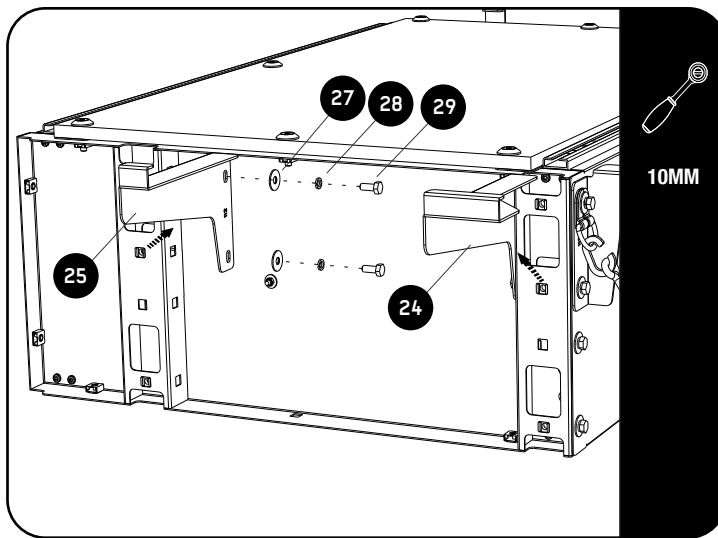

RH Side

⌚ Before fitting the Side Wings you need to relocate the cage nuts from the side of the pillars to the inside faces of the pillars.

Looking at the right side of the drawer, secure the Front RH Side Wing and the Rear RH Side Wing (Items 24 & 25) using M6x16 Hex Bolts, M6 Spring Washers and M6x19x1SS Flat Washers (Items 27, 28 & 29) as shown.

3.5

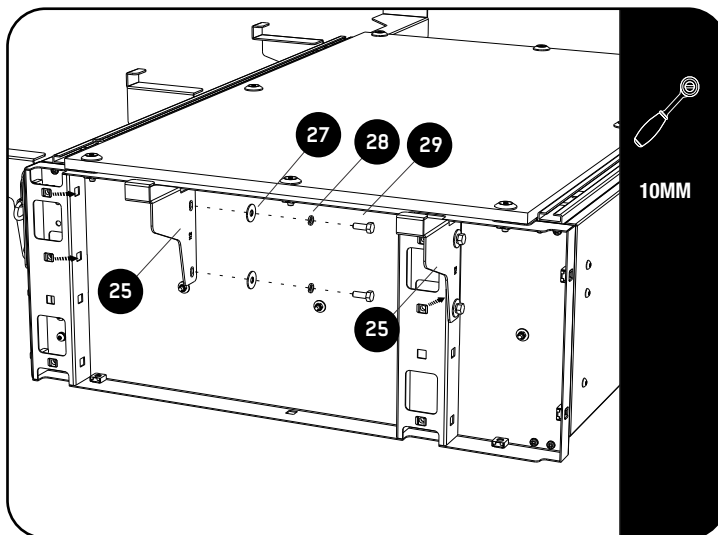

LH Side

⌚ Before fitting the Side Wings you need to relocate the cage nuts from the side of the pillars to the inside faces of the pillars.

Looking at the left side of the drawer, secure the Front and Rear LH Side Wing (Item 26) using M6x16 Hex Bolts, M6 Spring Washers and M6x19x1SS Flat Washers (Items 27, 28 & 29) as shown.

3.6

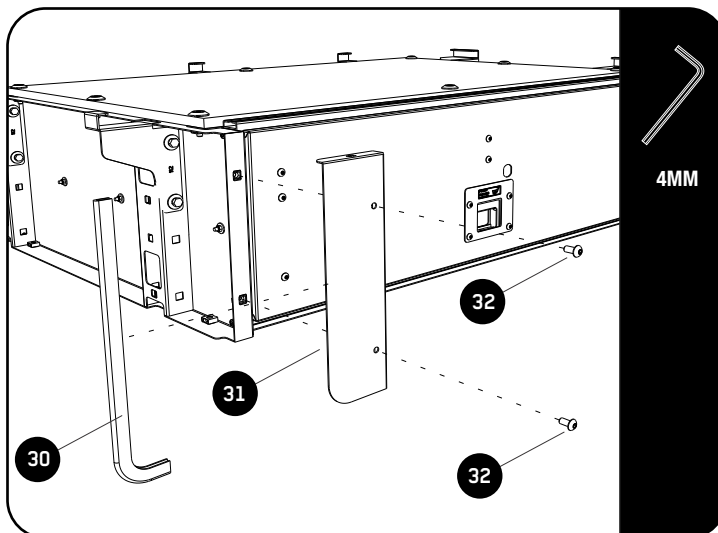

⌚ Fit the Pinch Weld (Item 30) to the Front Faces edge (Item 31).

Secure the Front LH and RH Faces (Item 31) to the Drawer System using M6x12 Button Head Bolts (Item 32).

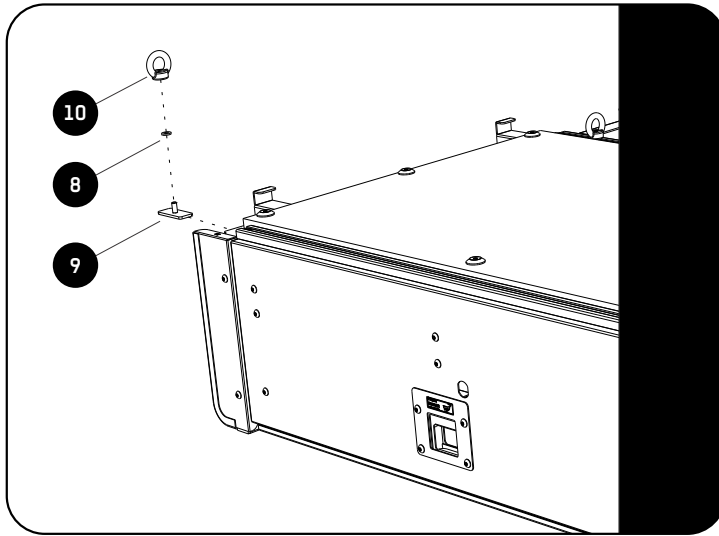
3**FIT AND SECURE****3.7**

Assemble the Eye-Nuts (Items 10) using the Stud Plates and Nylon Washers (Items 8 & 9).

Slide the assembled Eye-Nut into the extrusion making sure that the Nylon Washer is between the Eye-nut and the extrusion.

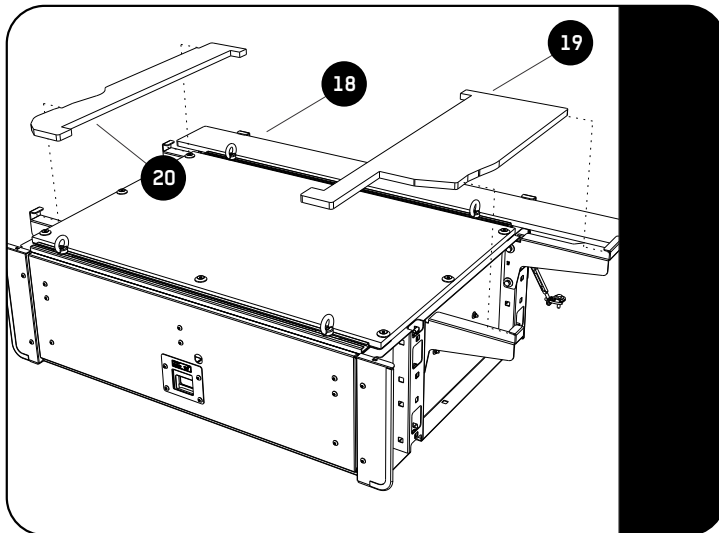
3.8

Place the decks onto the drawer starting with the rear deck.

4 COMPLETION

4.1



Congratulations. You did it. Take a step back and admire your work!

5 Front Runner will not be responsible for any damage caused by the failure to install the product according to these instructions. Please call us if you have any questions about the installation of this product.

6 INSTALL OTHER VEHICLE AND RACK ACCESSORIES

Now's the time to visit your favorite Front Runner Dealer in person or online.