













THE CRESTONE

I N S T A L L I N S T R U C T I O N S

HARDWARE CHECKLIST

Quantities marked in blue may be used in the preassembly of front adjustable mounts.
Exact hardware color counts may vary based on the options selected at checkout.

| | | | | | | | | | |
|---|---|--|---|---|--|---|--|--|---|
| 8 | 4 | 40 | 5 | 4 | 1 | 5 | 16 | 66 | 8 |
| M8-1.25 (45mm) | Carriage bolt (1/4"-20 x1") | 1/4"-20 x 1" Socket button | 1/4"-20 x 0.75" Socket button | 1/4"-20 (9/16") | 1/4"-20 (1/2") | 1/4"-20 Tnut | 1/4"-20 Nylock nut | 1/4" Flat Washer | M8 Bonded Washer |
|  |  |  |  |  |  |  |  |  |  |
| 2 | | | | | | | | | |
| FAIRING BRACKETS | FAIRING BRACE | | REAR MOUNTING BRACKETS | MIDDLE MOUNTING BRACKETS | | FRONT ADJUSTABLE MOUNTS | | | MOUNTING RUBBER |

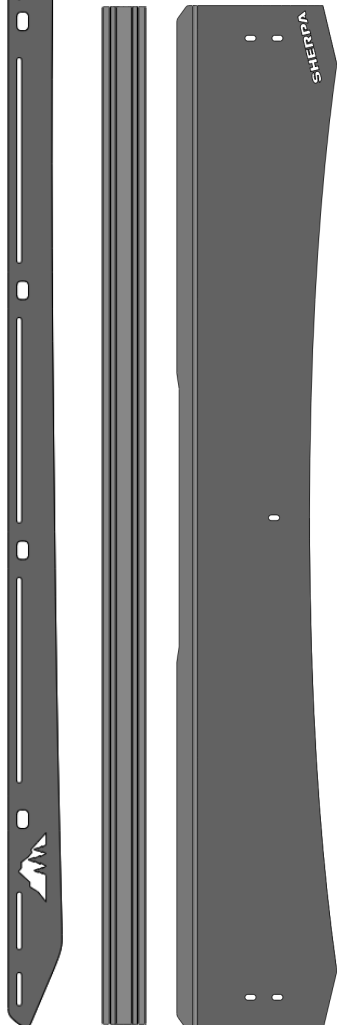

2x SIDEPLATES
7x CROSSBARS
1x FULL OR HALF FAIRING

BEFORE YOU BEGIN

Remove your stock roof rack (if applicable). Loosen all stock rack bolts before fully removing any of them. This will prevent the capture plates from working loose inside of the roof. Work slowly when removing the stock rack as not to break the plastic sleeves.

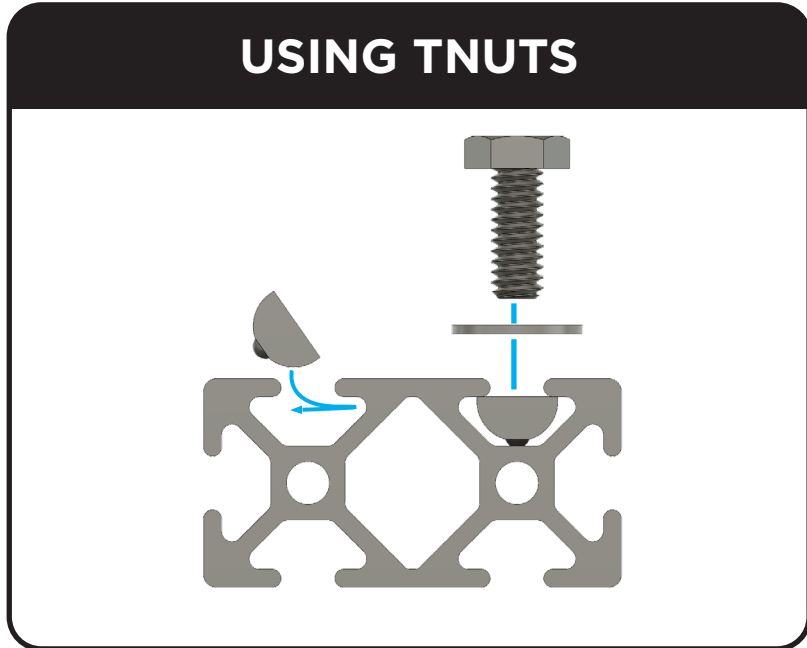

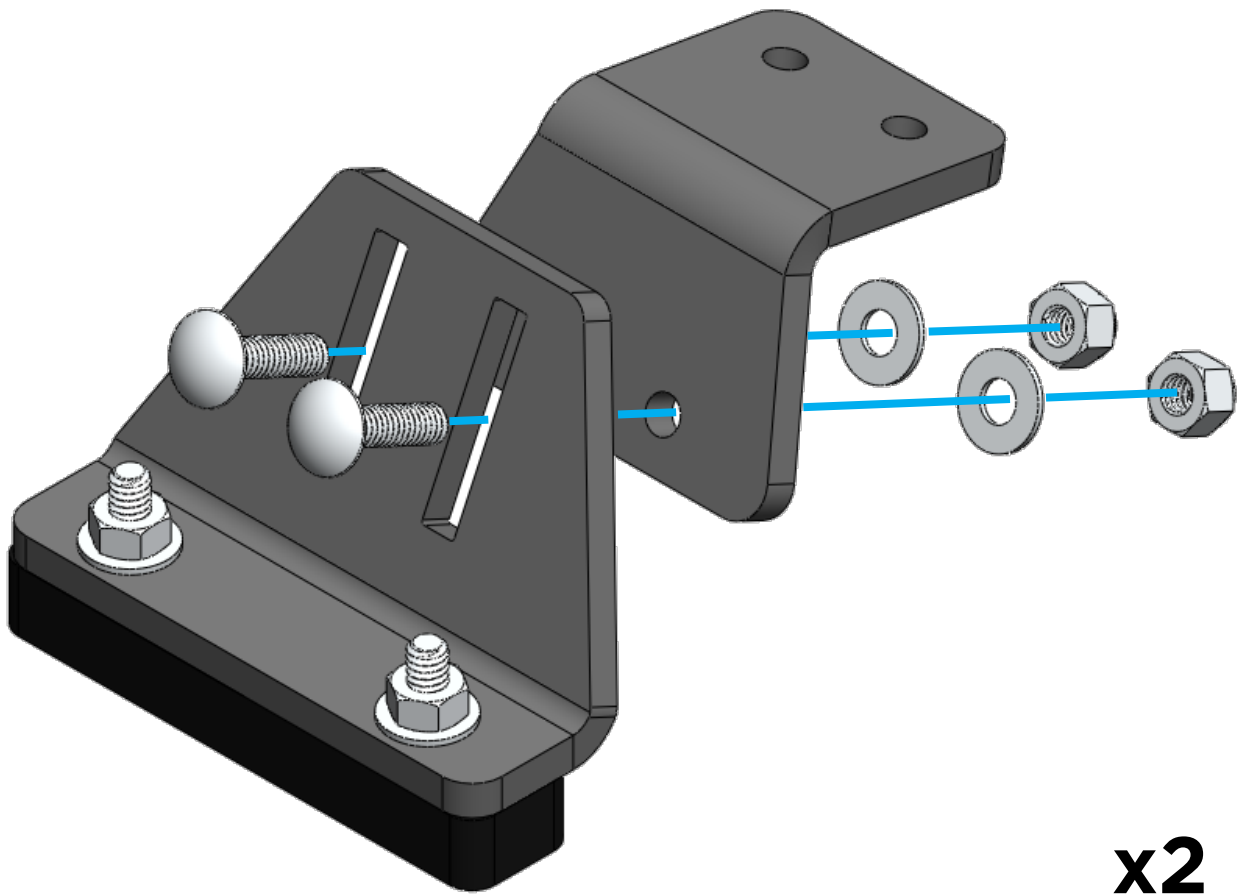

x2

PRE-ASSEMBLY

Required Components:

4x 1/4"-20 x 1" Carriage bolt

4x 1/4" Flat Washers

4x Nylon Lock Nuts

Install the hardware as pictured above, but leave the assembly loose so that it can be adjusted during a later step.

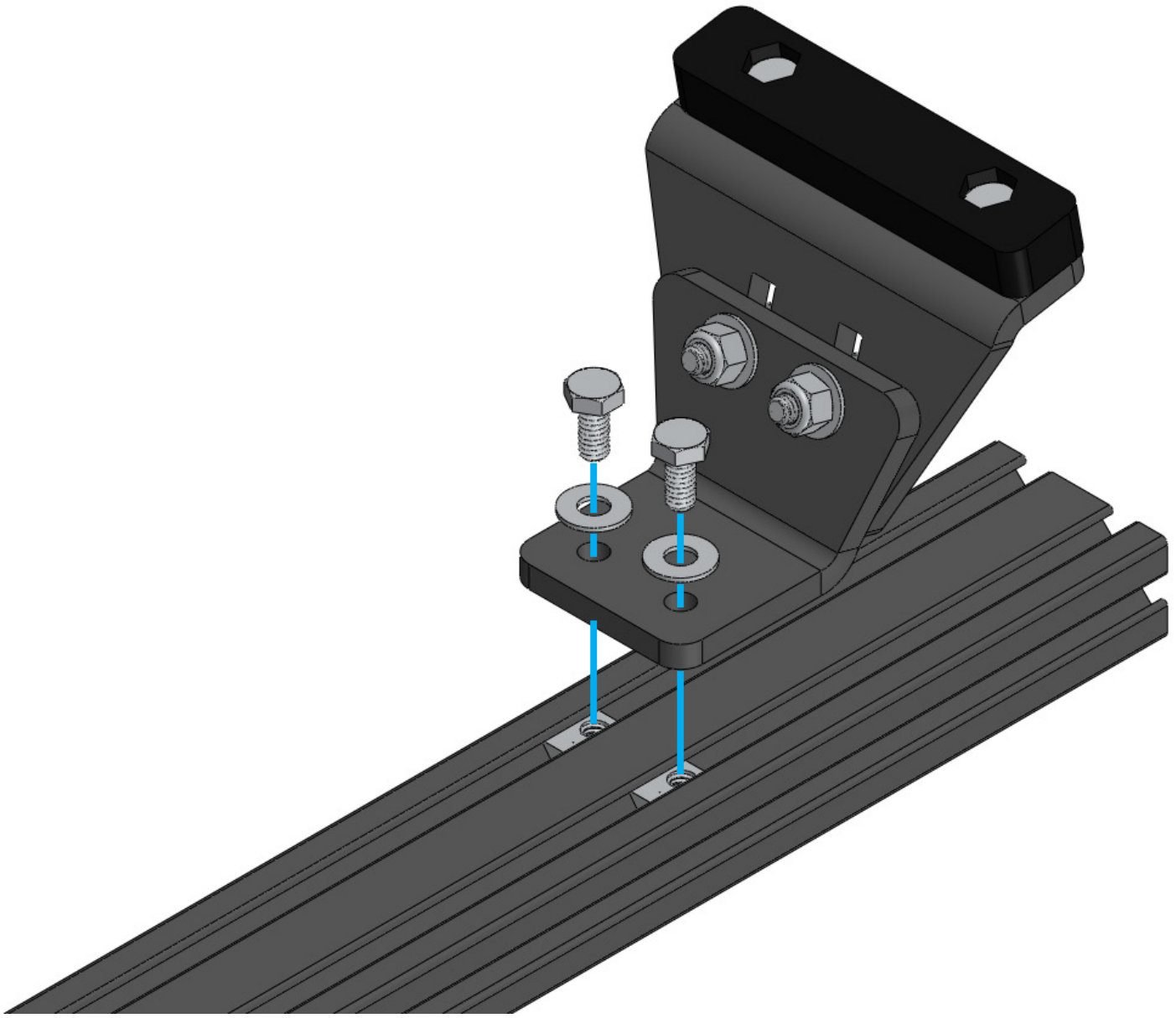

01

Required Components:

4x 1/4"-20 x 9/16" Hex bolt

4x 1/4" Flat Washers

4x T-nuts

Drop two t-nuts into the slotted profile of the extrusion. Fasten the front leveling mounts to the crossbar by threading 4 bolts and washers through the leveling bracket and into the t-nuts. Repeat this step so that both adjustable feet are mounted to the same crossbar. This will serve as the front mount assembly.



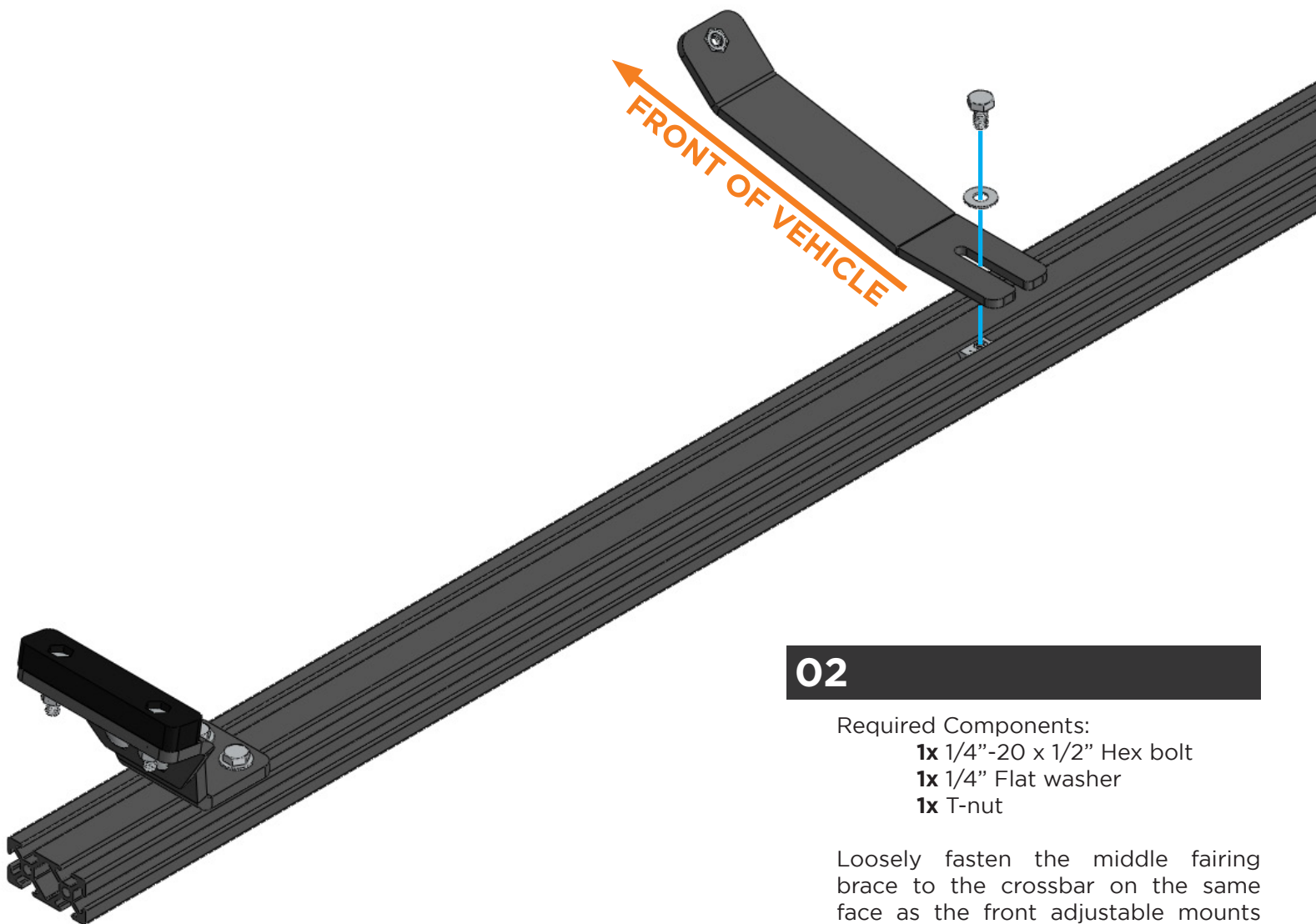

02

Required Components:

- 1x** 1/4"-20 x 1/2" Hex bolt
- 1x** 1/4" Flat washer
- 1x** T-nut

Loosely fasten the middle fairing brace to the crossbar on the same face as the front adjustable mounts using the supplied 1/4"-20 x 1/2" hex bolt, flat washer, and t-nut. Note that the hardware will run through the 'far' channel in relation to the fairing. Slide the brace to the center of the crossbar and leave loose.



03

Required Components:

8x M8 Bolts

8x M8 Flat Washers

Install the rear and middle mounting brackets. The tall side of the bracket should **face out from the vehicle**. Align the rubber spacers with the factory holes in your roof gutter. The metal sleeves should slide over the OEM white plastic tubes. The thin side of the rubber should be positioned towards the center of the vehicle.

Position the mounting bracket over the rubber spacer and secure it with 8 bolts and bonded washers passed through the bracket, rubber, and into the holes in the roof.

The bonded washers should compress and become flat, but not concave. Do not over tighten these mounts.

TORQUE SPEC: 22in-lb

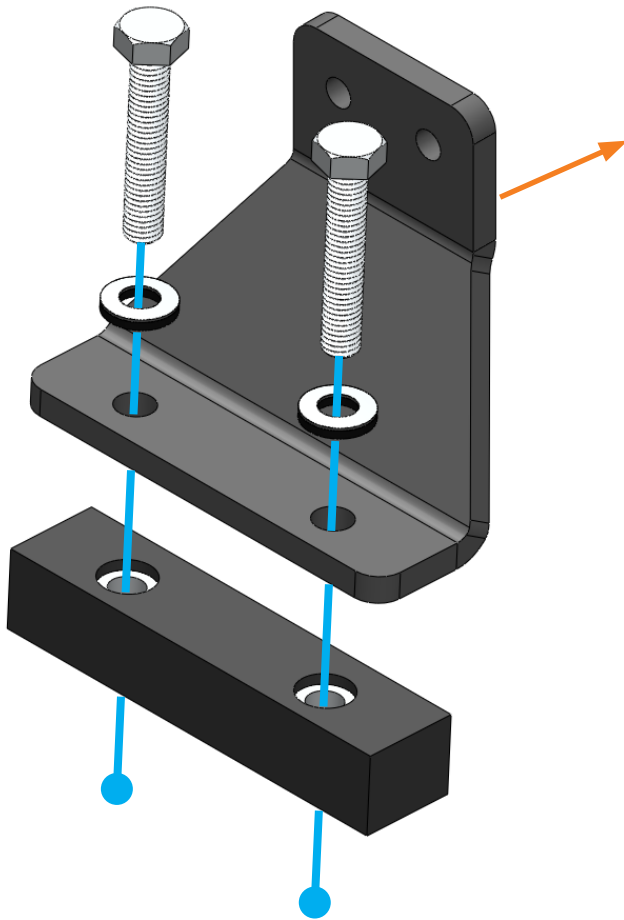

04

Required Components:

8x 1/4"-20 x 1" Socket button

16x 1/4" Flat Washers

8x 1/4" Nylock Nut

Install the sideplates by aligning the **designated slots** with the holes in the rear and middle brackets. Secure it using the supplied socket buttons, washers, and lock nuts. Leave the bolts loose enough for the sideplate to slide forward and back in relation to the vehicle.

Install the rear crossbar to check the rack clearance with the XM antenna before tightening hardware.

Once the rack is positioned correctly, tighten down all of the hardware for the sideplates and roof bolts.

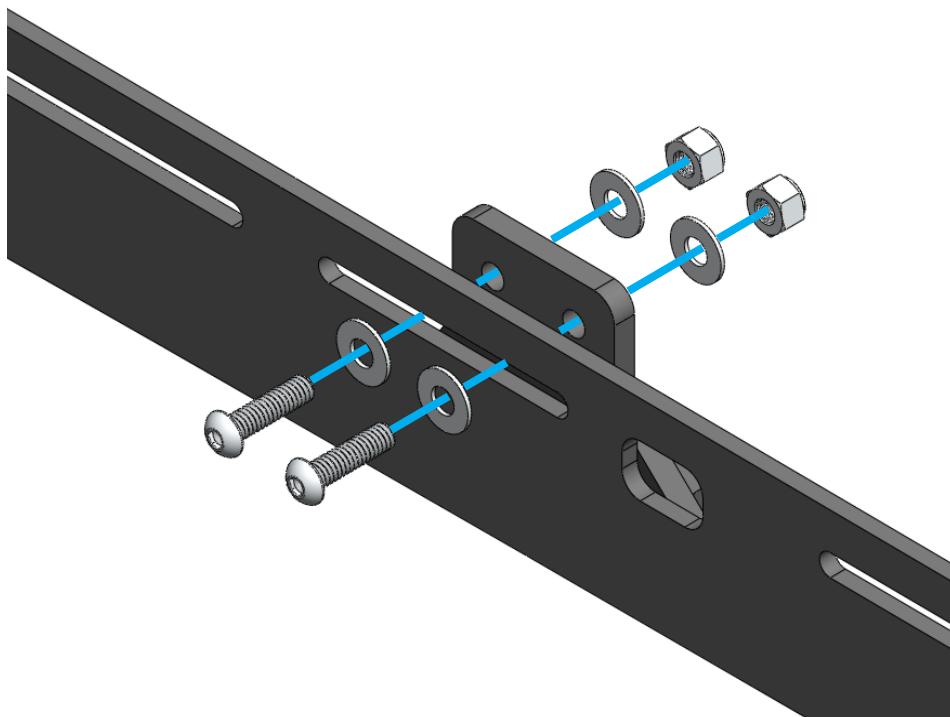

FRONT

MIDDLE

REAR



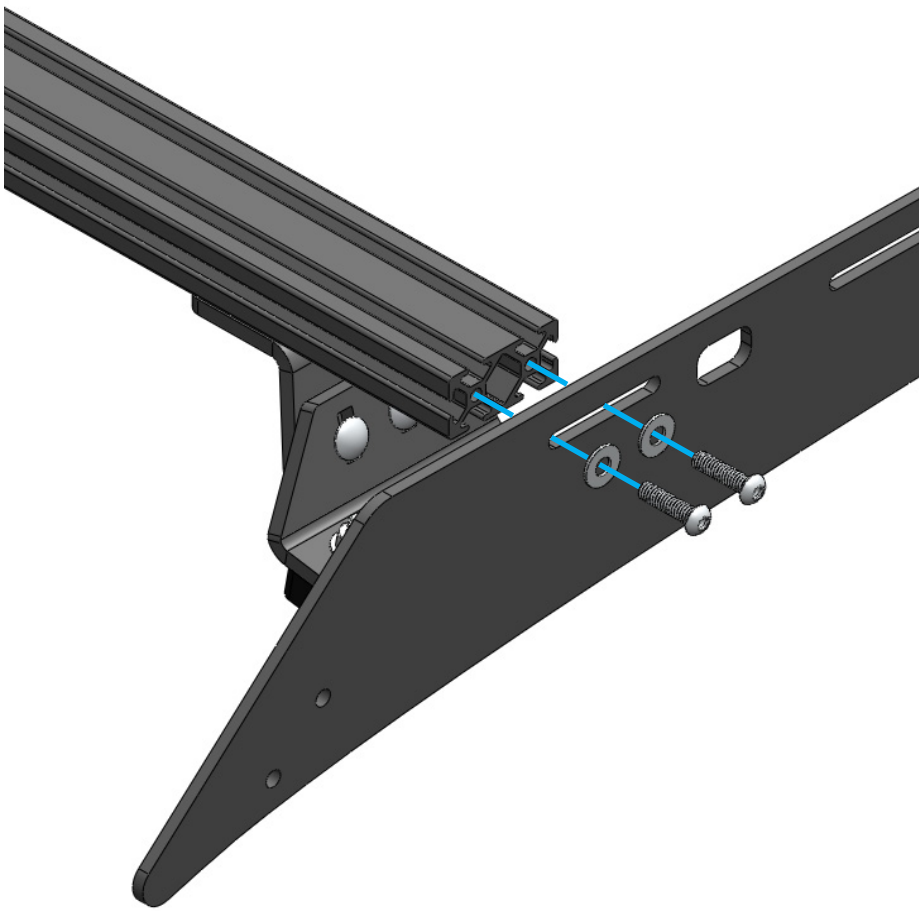

05

Required Components:

4x 1/4"-20 x 1" Socket buttons

4x 1/4" Flat Washers

Fasten the front adjustable mount assembly to the sideplates by bolting into the crossbar with the supplied socket buttons and washers in the designated slot (refer to the diagram in step 04).

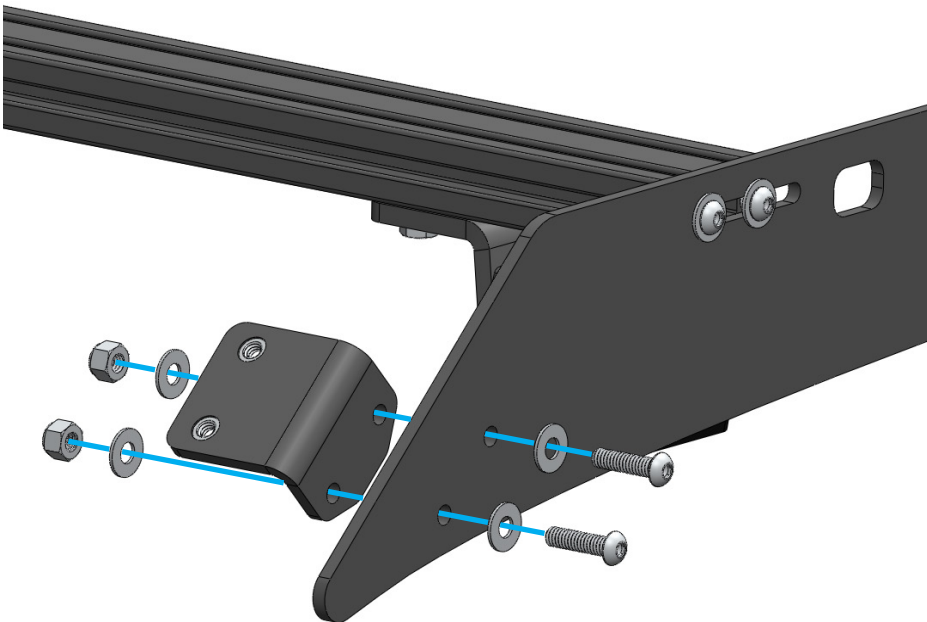

06

Required Components:

4x 1/4"-20 x 1" Socket buttons

4x 1/4"-20 Nylock nuts

8x 1/4" Flat washers

2x Fairing brackets

Fasten the fairing brackets to the inside face of the sideplates using the supplied socket buttons, washers, and nylock nuts, as pictured.

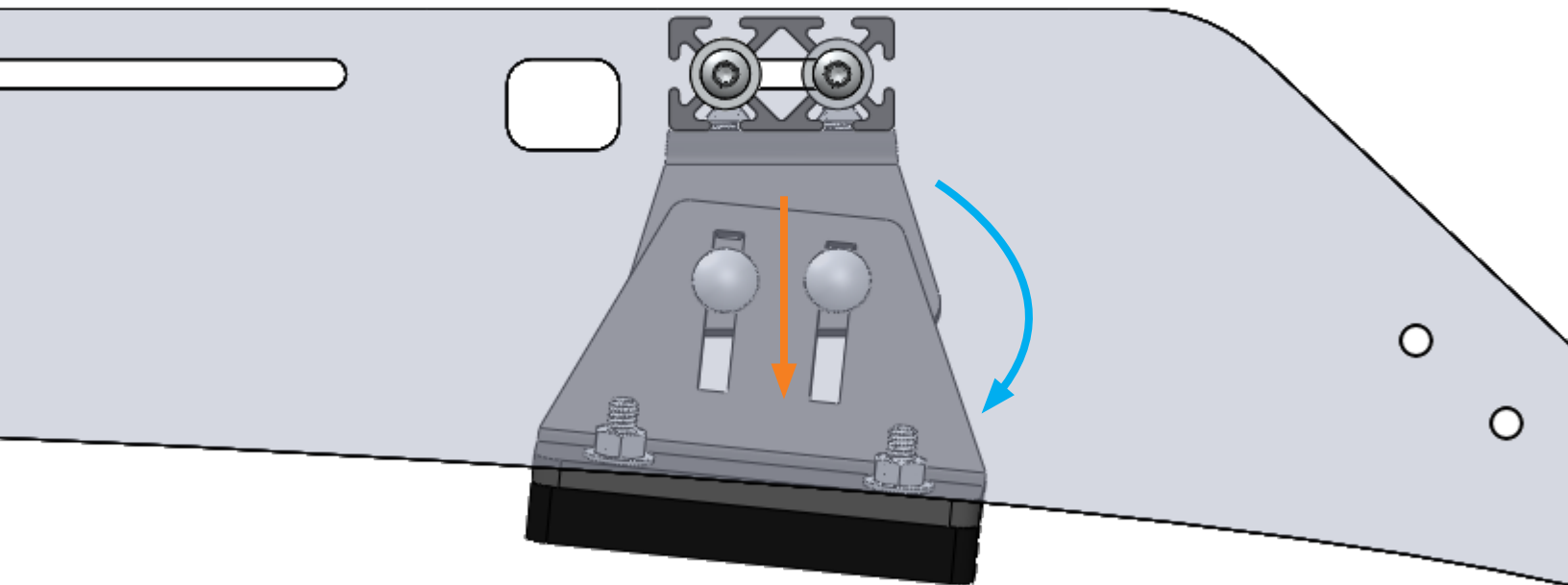

07

*We recommend an extra set of hands for this step. You may also need to loosen the middle mounts for this step depending on your configuration.

Apply upward pressure on the front of the rack and insert a microfiber towel or other soft buffer between the front of the rack and the vehicle's roof. Adjust the **angle** and **height** of the mounting foot to sit as firmly on the vehicle's roof as possible, then tighten the hardware in the center of the mount. It is recommended to position these mounts on the plastic gutter trim to prevent possible paint damage.

Once the mounts are in the correct position, remove the buffer and inspect the rack to make sure it is firm.

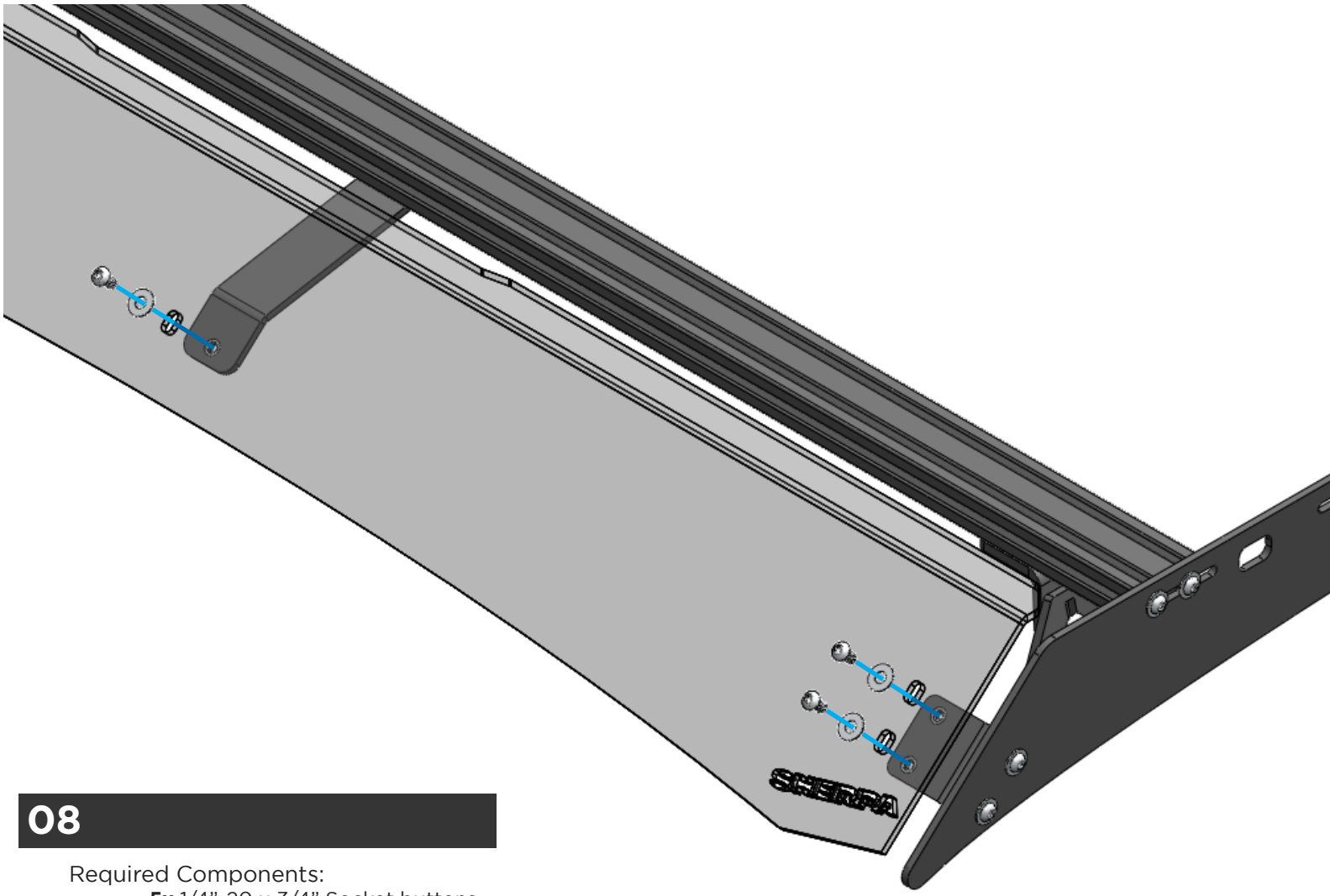

08

Required Components:

5x 1/4"-20 x 3/4" Socket buttons

5x 1/4" Flat washers

Place the fairing over the fairing brackets and fasten it to them using the supplied 1/4"-20 x 1/2" socket buttons and flat washers. **Do not exceed 35 in-lbs.** The hardware should be centered in the slots, but can be adjusted slightly up or down if needed. The bottom edge of the fairing should sit roughly 1/2" above the vehicle's roof and should not contact at any point.

TORQUE SPEC: 35 in-lb

Once the bracket hardware is tightened, move the fairing brace to the middle slot and install the final socket button and flat washer.

Tighten the **hex bolt** in the fairing brace under the front crossbar.

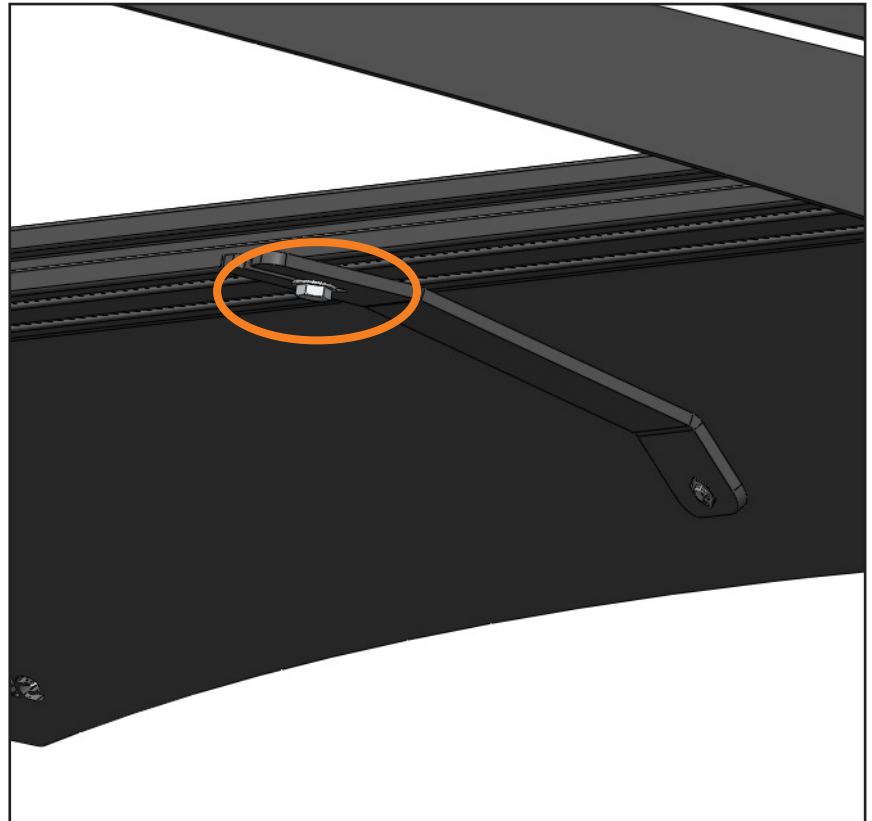



09

Required Components:

24x 1/4"-20 x 1" Socket buttons

24x 1/4" Flat Washers

6x Crossbars

Secure all of the remaining cross members to the rack system. Position according to your load requirements. Heavy loads should be evenly distributed across multiple crossbars are spaced accordingly.

EXPLORE.



All products built and designed by Sherpa Equipment Company are intended for off-road use and should be assembled, installed, and used according to Sherpa Equipment Company's recommendations. Sherpa Equipment Companies products should be used safely with good judgment towards others and surroundings.

By installing Sherpa Equipment Companies products on your vehicle you assume all liability. Sherpa Equipment Company will not be held liable for damages or loss associated with the installation or use of its products. It is recommended that you inspect your roof rack within the first 100 miles of installation and every 500 miles after.