

REV PLATFORM X

ASSEMBLY INSTRUCTIONS

SKU: 6PK3BK3

Hi! This was written for you. Yes, you. Please read. Don't be a hero and muscle ahead blindly. You must read all the instructions (including the **WARNINGS!**) Take each step in order. It's quicker in the long run and you won't have to double back to fix mistakes.

If any of the small parts go missing (we won't blame you if you don't blame us!) note that there is a packet of spares.

ESTIMATED ASSEMBLY TIME: 2 hours

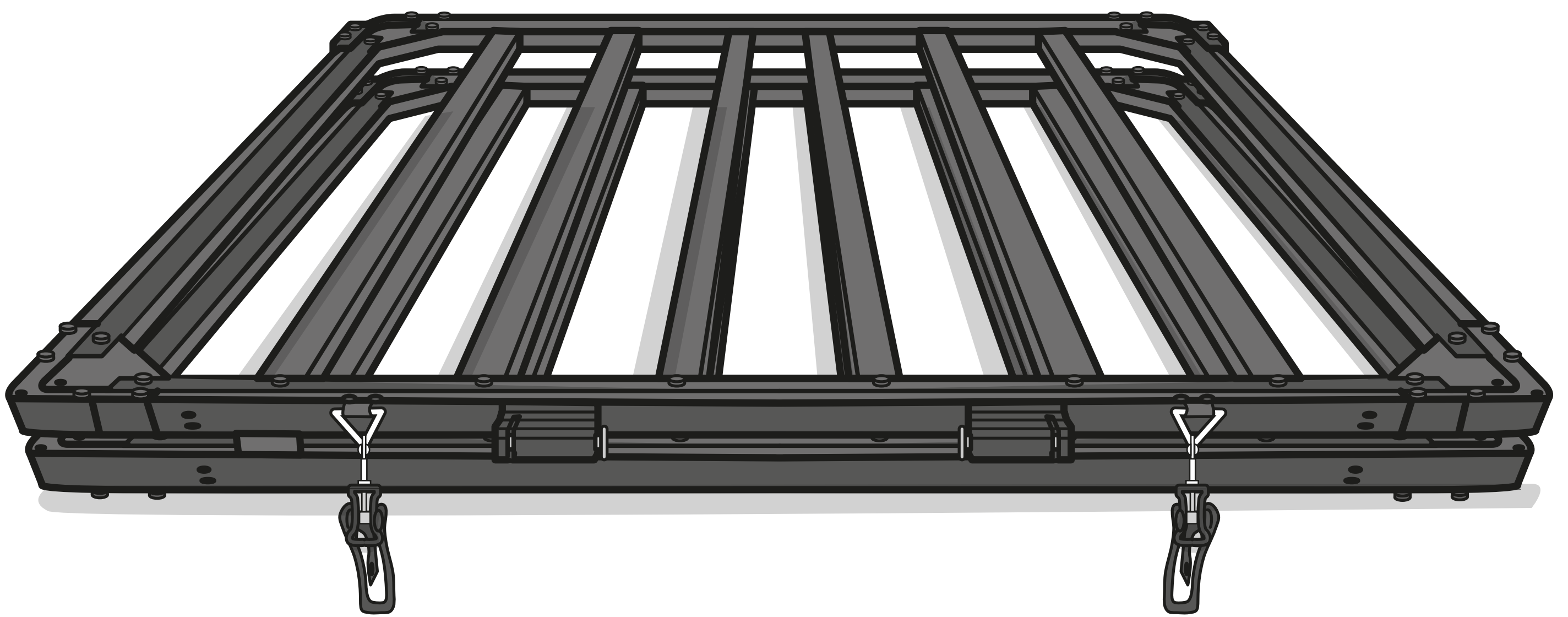



WARNINGS

Failure to follow instructions could result in injury and even death. Attaching gear to your vehicle must be taken very seriously. Any questions or concerns about assembly or installation please contact support@C6outdoor.com

When transporting the Rev Platform you **MUST** latch the platform closed and you **MUST** secure all 4 corners of the Rev Tent using the supplied hardware.

When securing the Rev Tent and Rev Platform to a vehicle for transport - check all connections and straps often. Failure to properly secure the Rev Tent, Platform and Ladder to a vehicle could result in damage to the gear and bodily harm.

Please check with your vehicle manufacturer for specified loading capacity of your roof and carrying system. Not all factory roof carrying systems or aftermarket cross bars can safely accommodate the Rev Roof Top Tent (Rev Tent & Rev Platform). The Rev Roof Top Tent system weighs @87lbs / 40kg.

When using the Rev Platform for camping with the Rev Tent - the Rev Ladder must be secure, extended and locked in place before climbing. Position ladder to fully support platform. Failure to do so could damage the platform and you.



GET READY

- Put on the C6 Outdoor wristband.





GET ORGANIZED

SUMMARY Getting prepped properly now will save you time and energy later.

- **Prepare work area.**

You will need a flat, clean work surface at least 7'x 5' / 213cm x 152cm. A clean floor will do!

- **Remove top ladder box and parts box.**
- **Remove the tool packet from the parts box.**

Included tools

- 1 13mm ratcheting wrench
- 2 4mm hex keys
- 1 5mm hex key
- 1 6 mm hex key
- 1 phillips head screwdriver

 You may also need a rubber mallet or hammer with a small towel.

- **Set out all the hardware packets.** Do not dump out the contents! Leave the parts in the bag to keep organized.

 We have included spares for emergencies.



LAY OUT EXTRUSIONS

SUMMARY There is a top side and bottom side to each piece of extruded aluminum. For this layout, we're putting the bottom of the platform facing up. Make sure the real life pieces you are laying out look like the pieces in the drawing below. Make it match. This is fun! Like laying out the bones of a Halloween skeleton decoration.

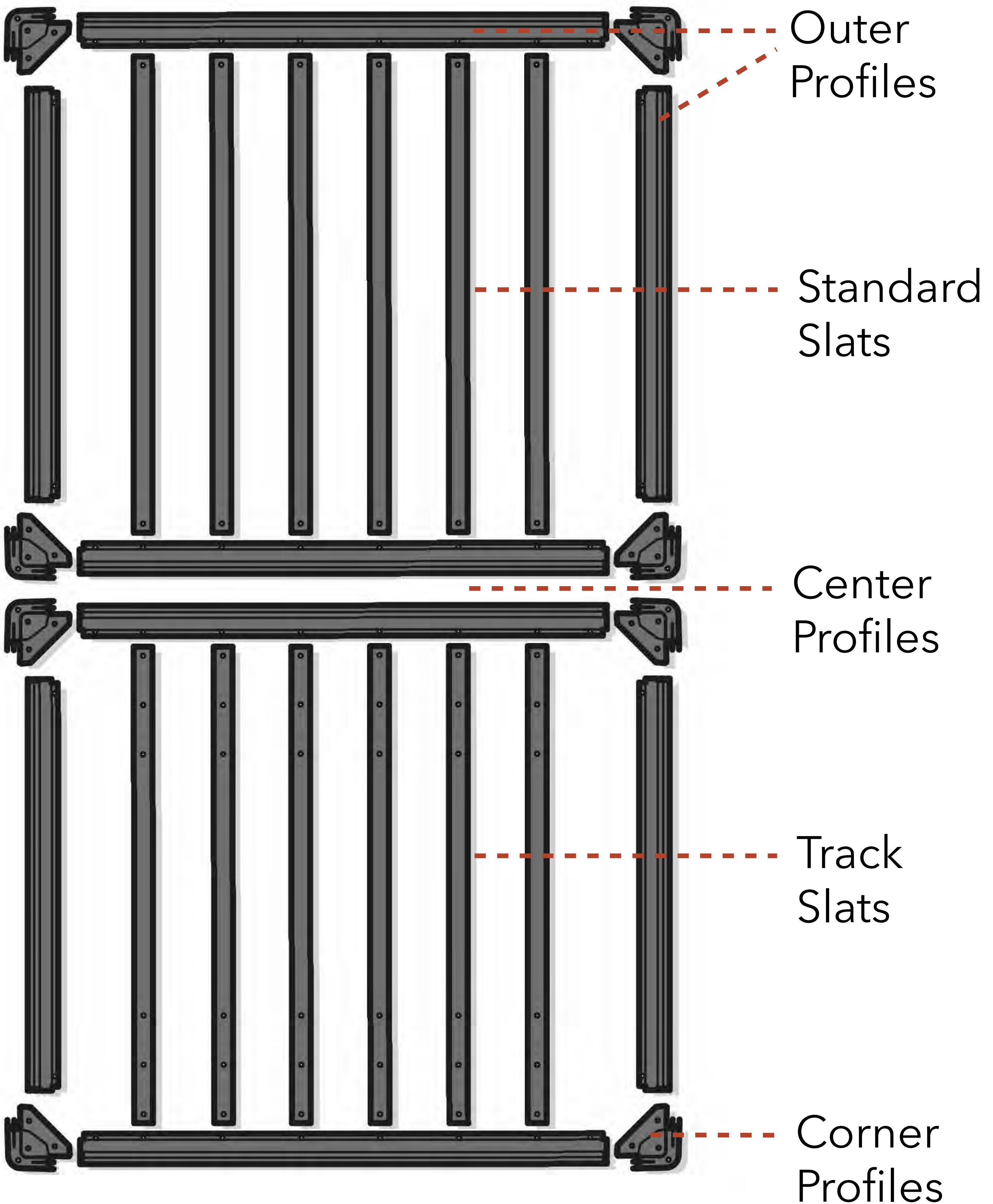



- **Identify and place the center profiles.**

The center profiles “lock” together. 2 channel slots face up, 1 channel slot faces down.

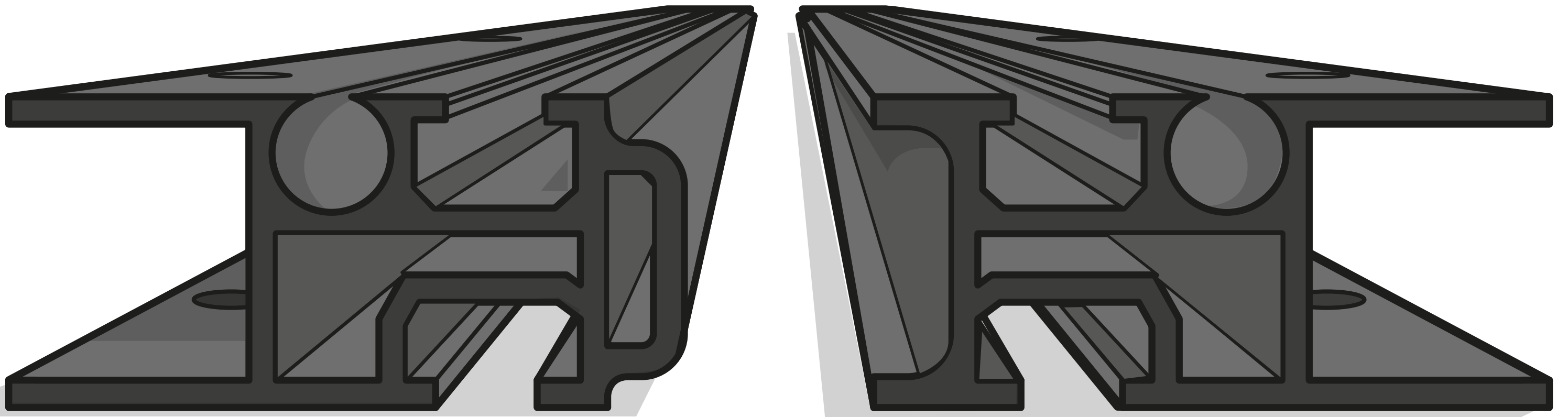

- **Identify and place the outer profiles.**

2 channel slots face up, 1 channel slot faces down. The shorter extrusions are the sides; Longer extrusions are the ends. Refer to illustration!

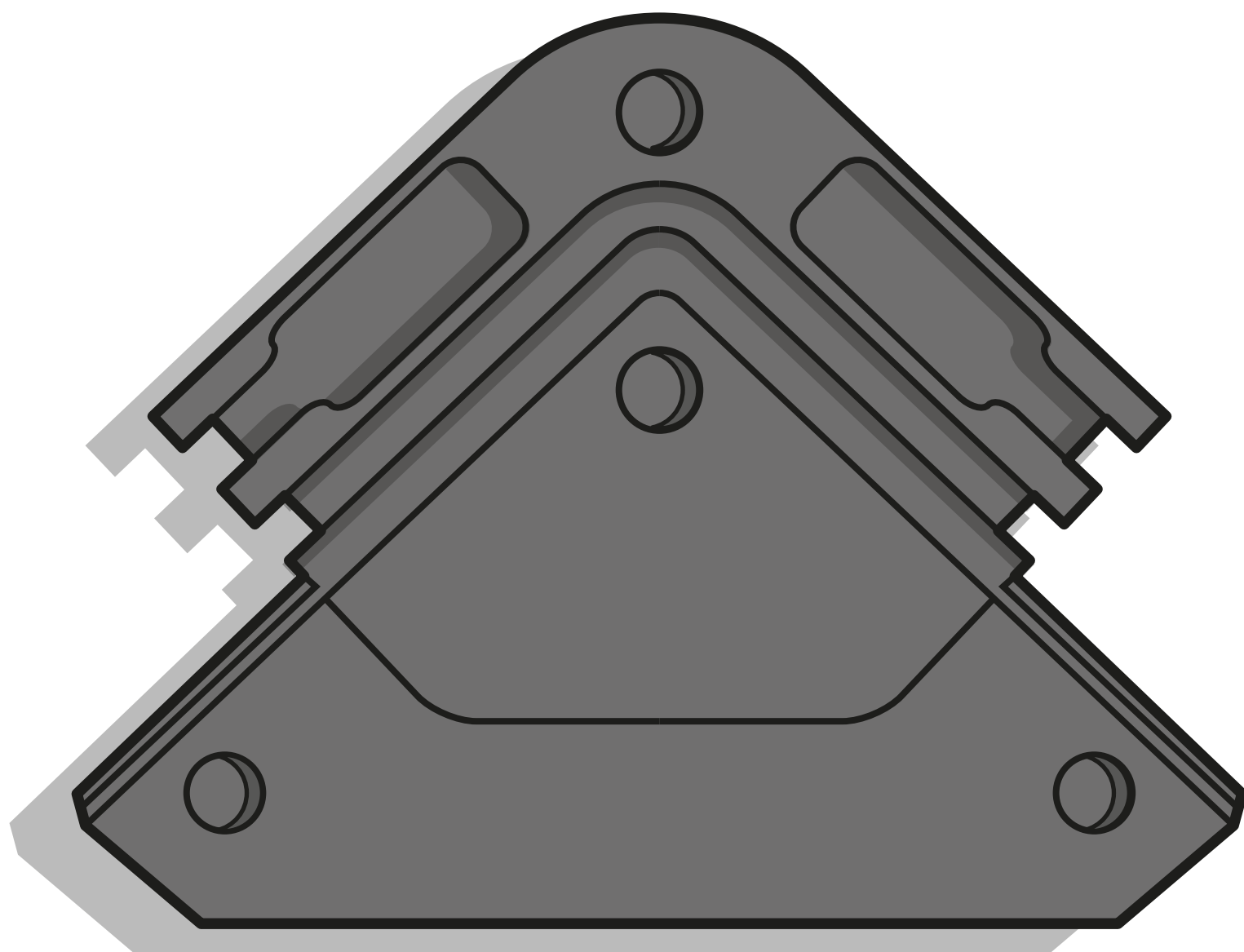
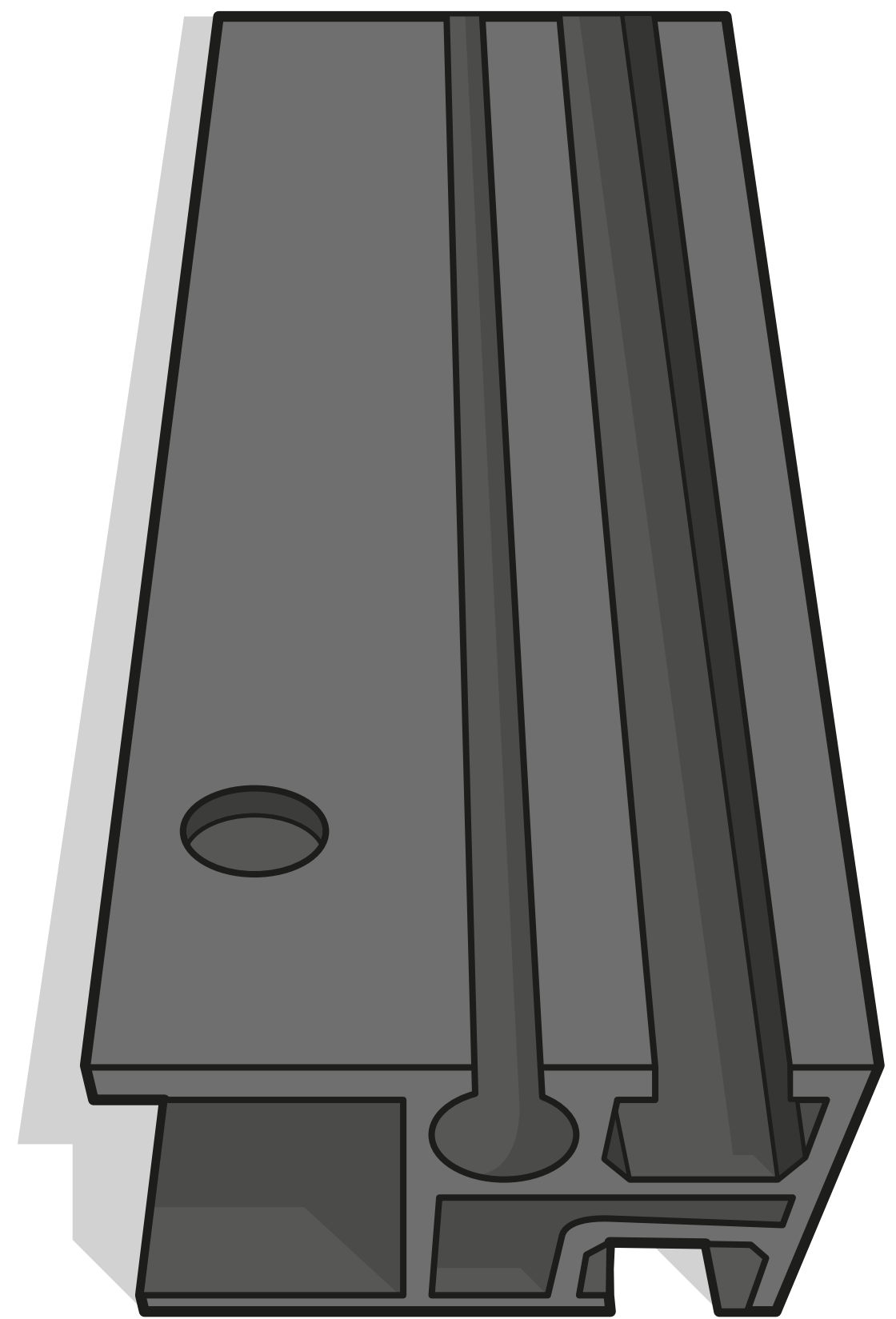

- **Place corner profiles.**

The C6 logo should be upside down.



- **Identify and place the track slats.**

These are the slat extrusions that have multiple holes and cut outs. (These extra holes will be used in a later step to attach the bottom square tracks.)

The cut outs face down, holes face up.



- **Identify and place the standard slats.**



All the standard slats go on one side of the platform, the track slats on the other.

- **Set aside these 2 square tracks. We'll get to them later.**



Good job! **All** you have to do now is bolt the Rev Platform together and add the hardware!



ASSEMBLE 4 OUTER CORNERS & BOTTOM BRACKETS

SUMMARY The slider nuts go in the outer profile channels, spring/ball facing down (**packet A**). Line the nuts up with the holes on the narrow metal corner bottom bracket. Use the bolts (**packet B**) with the spring washers (**packet C**) to secure the corner metal bottom brackets to the corners.

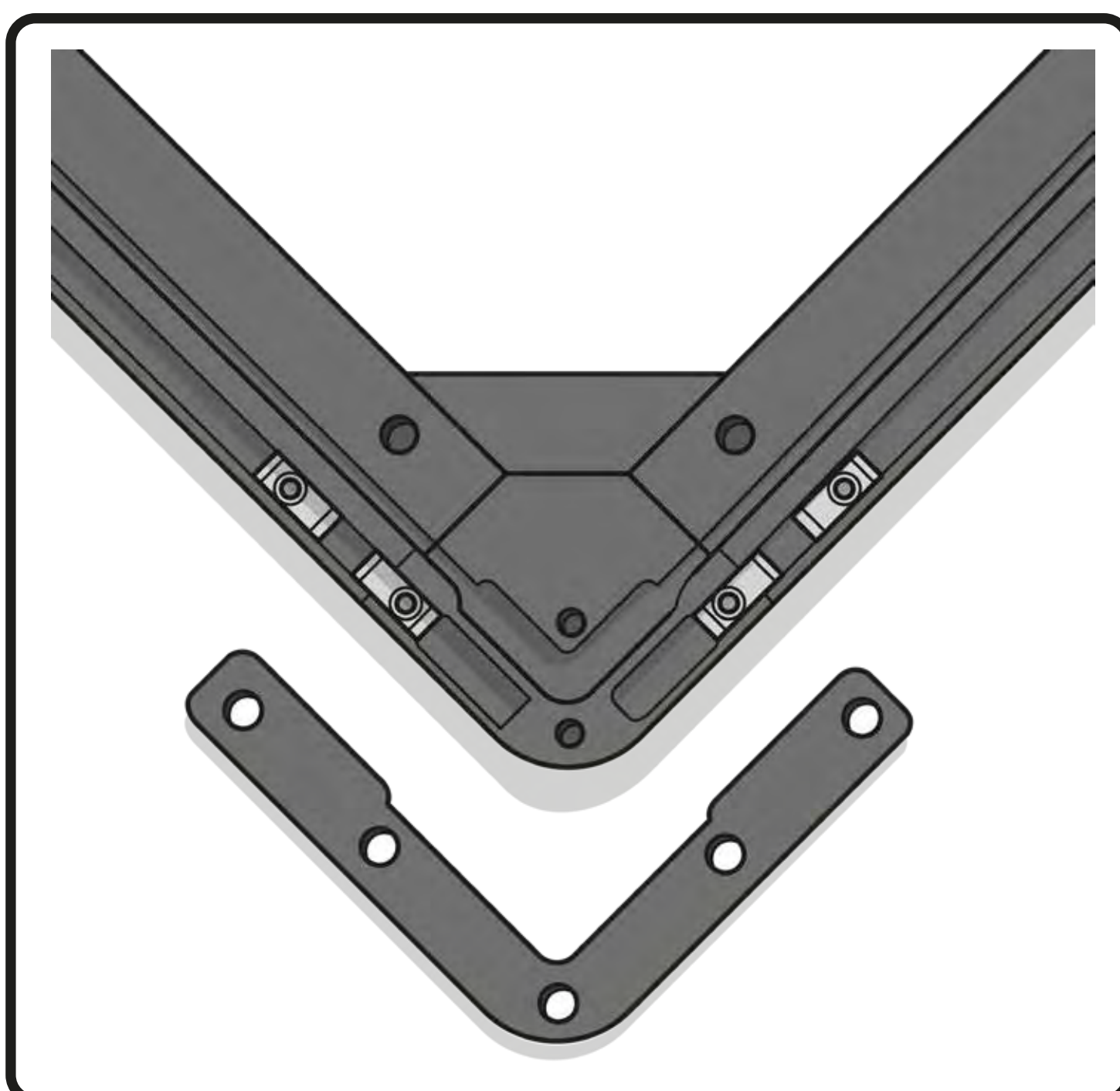
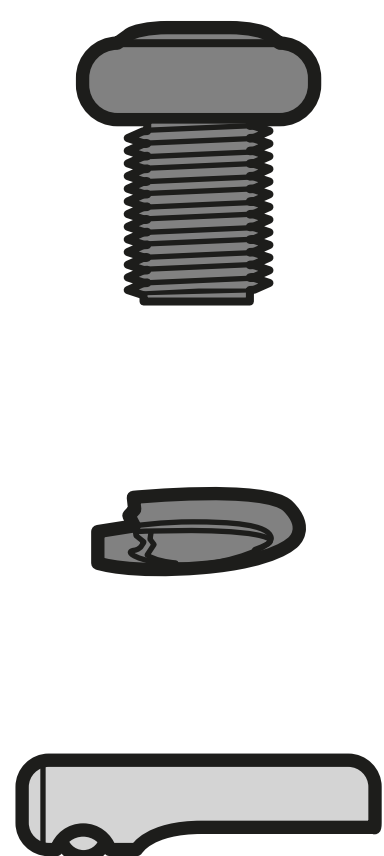
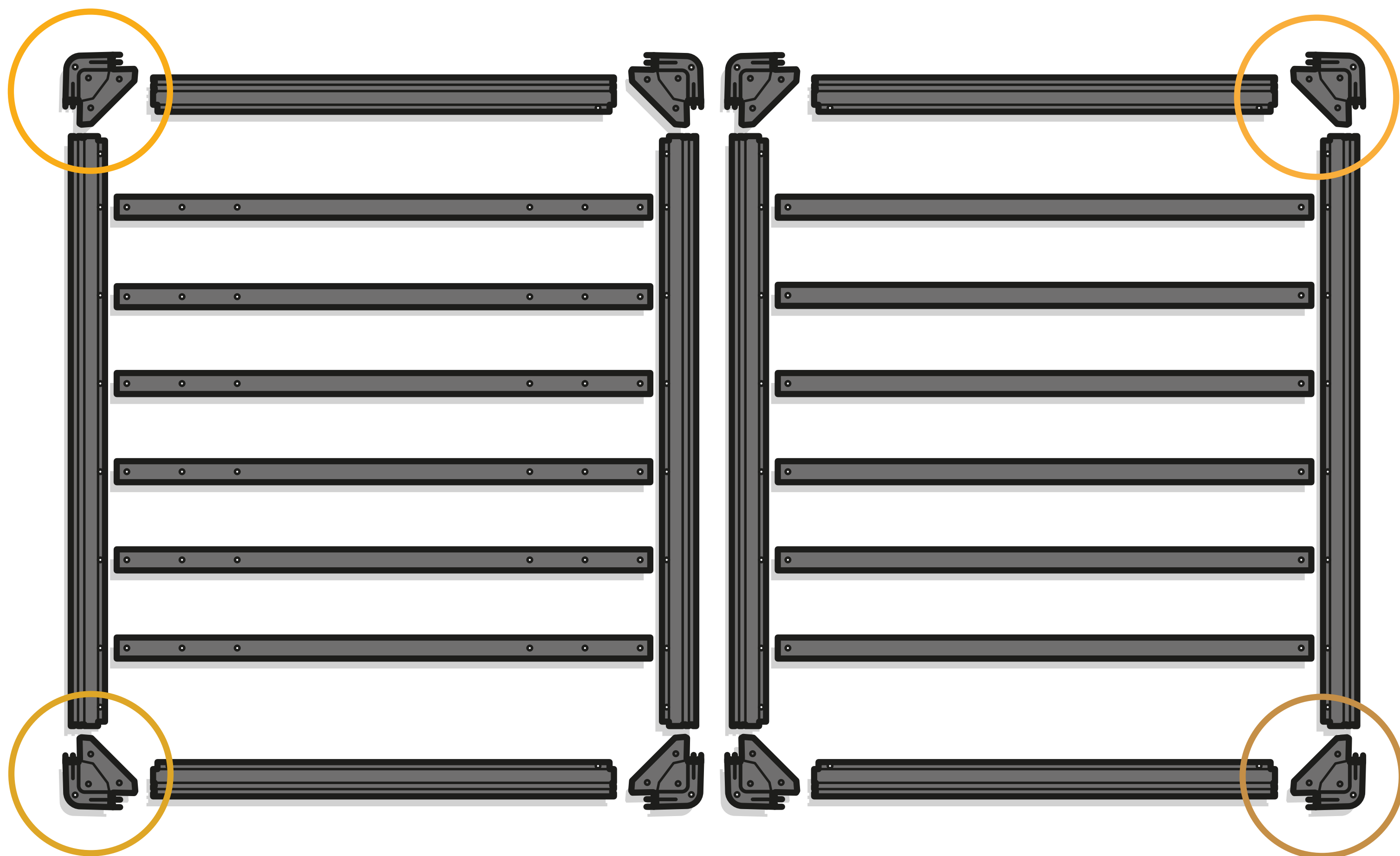



- Push corner piece in to outer profiles.

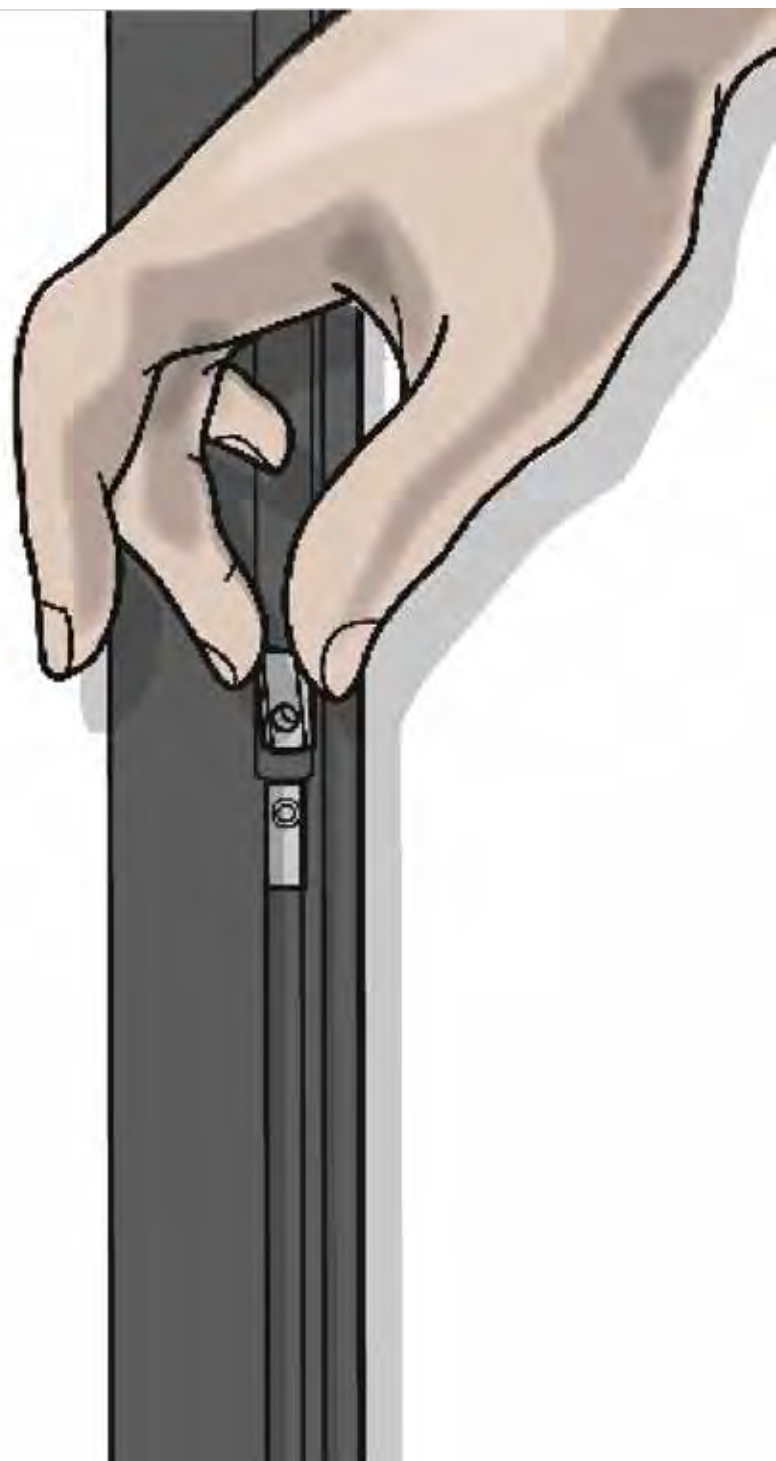
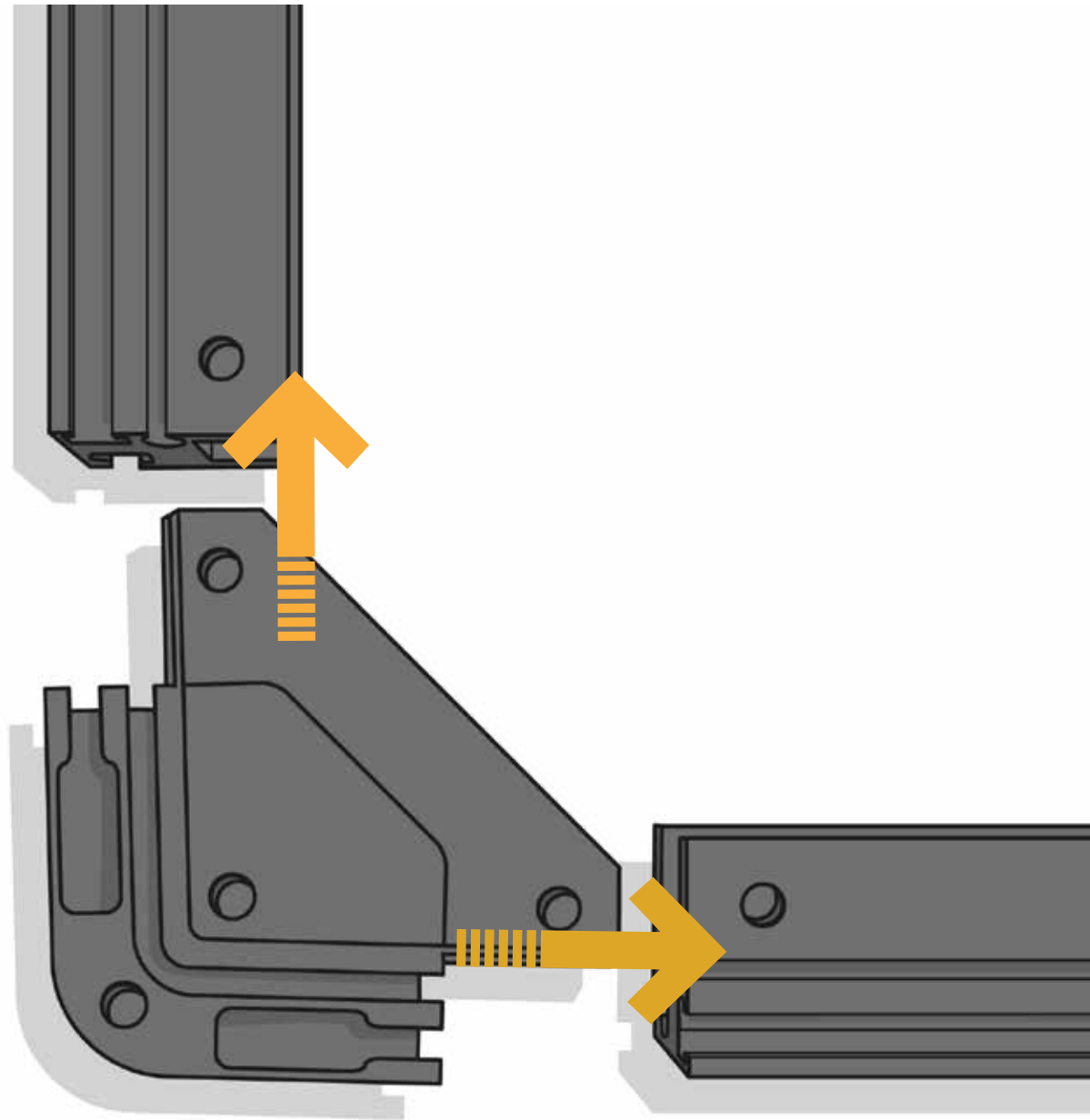

- Insert 2 slider nuts (**packet A**) into channel and line up position of nuts.

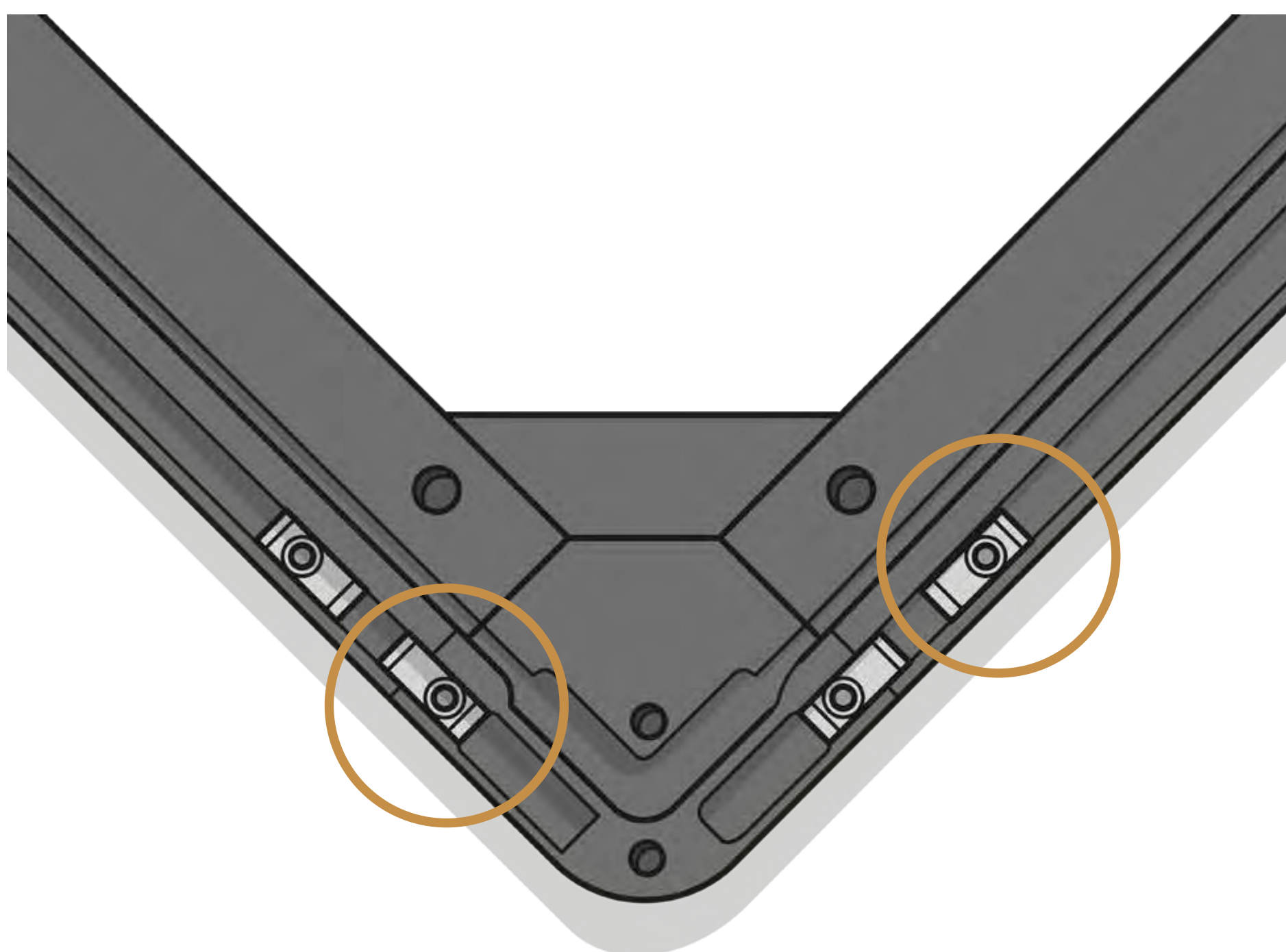

i Ball spring faces bottom of channel. Note direction/placement of nut holes.

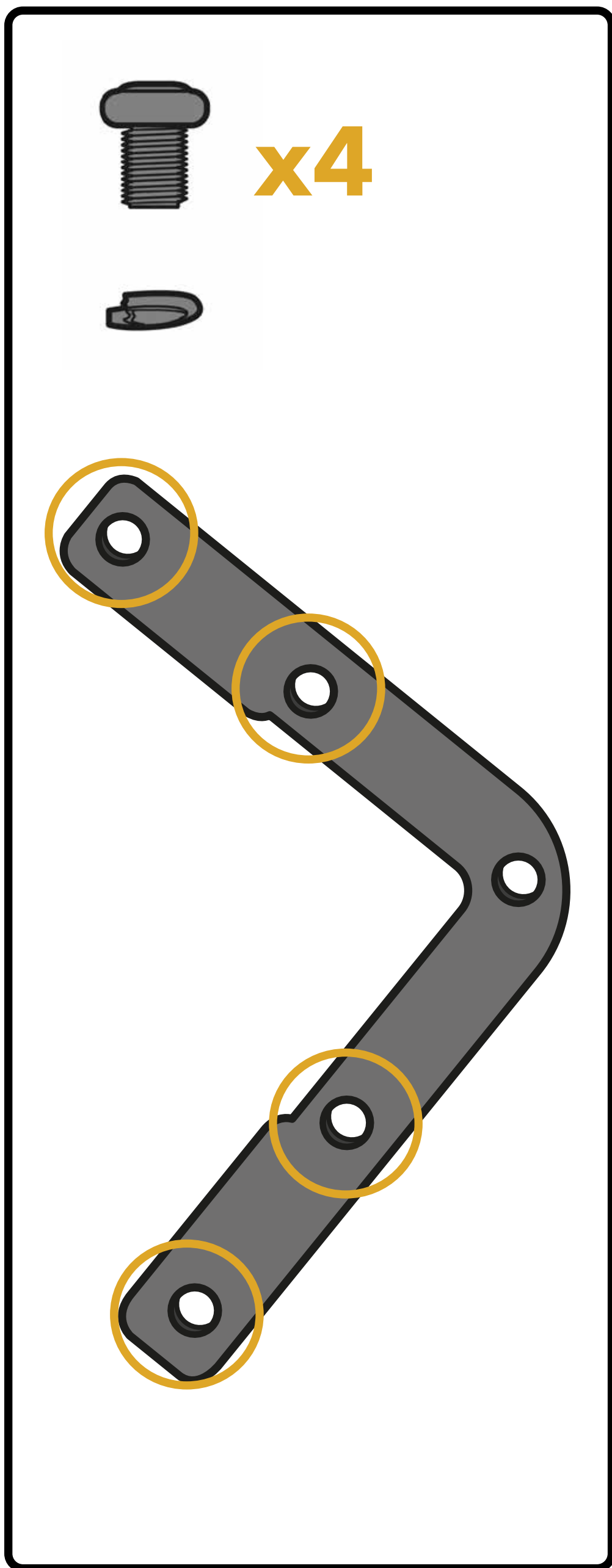

- Use the bolts (**packet B**) and spring washers (**packet C**) to secure the narrow corner bracket to the platform outer corners.

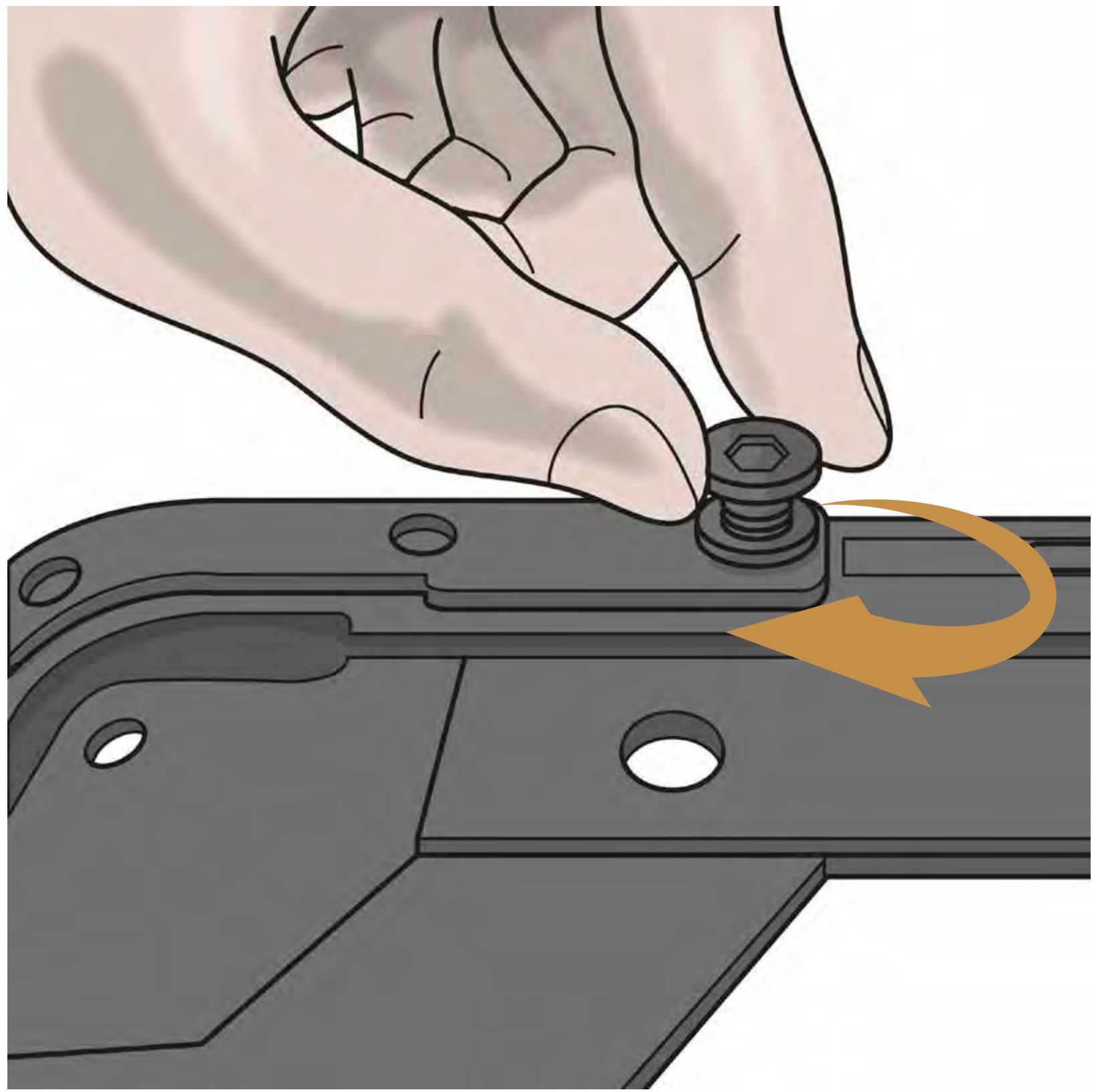

i Line up the slider nuts as exact as possible before you place the corner bracket. If you have to adjust the slider nut position after you've bolted the bracket down, use an hex key to push the problem slider nut into position.

- Secure all 4 bolts with half turn only. Do not over tighten! You'll do a final tightening pass later. Leave them tight enough not to fall out, and loose enough that you can make minor adjustments later...

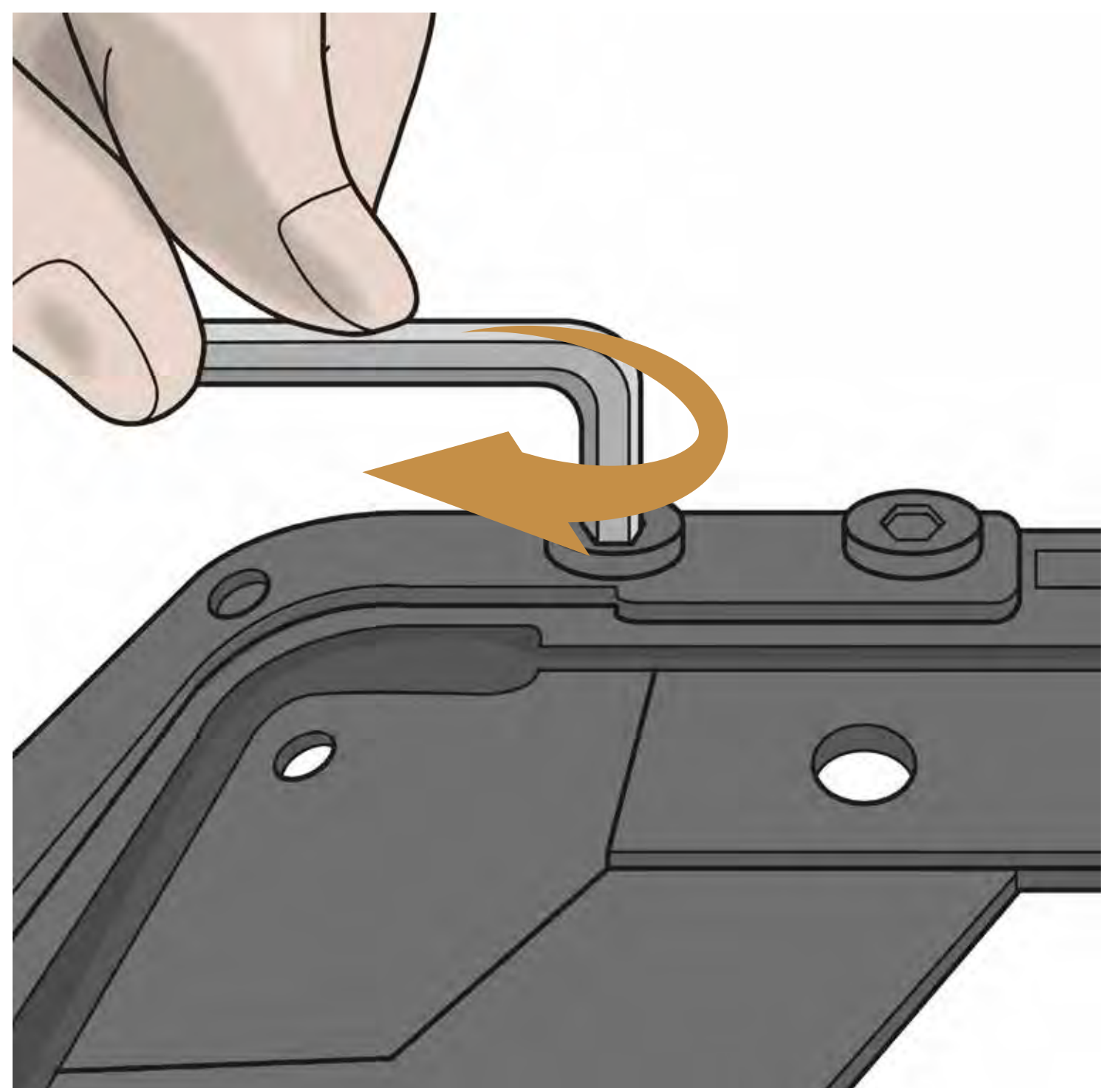



- Now it's time to assemble the other 3 outer corners.

Repeat these steps. Again, only work on the outer corners! And don't forget to leave all bolts slightly loose. You will need a little bit of wiggle room to make adjustments in a later step.



ASSEMBLE CENTER CORNERS, BOTTOM BRACKETS & HINGES

SUMMARY These center corners have the hinge plates bolted to them. So you will be using slightly longer bolts to secure the hinge plates correctly on the outer facing profiles (**packet D**). Other than adding the hinges to the outer profiles and using the different length bolts, the steps are similar to assembling the outer corners.

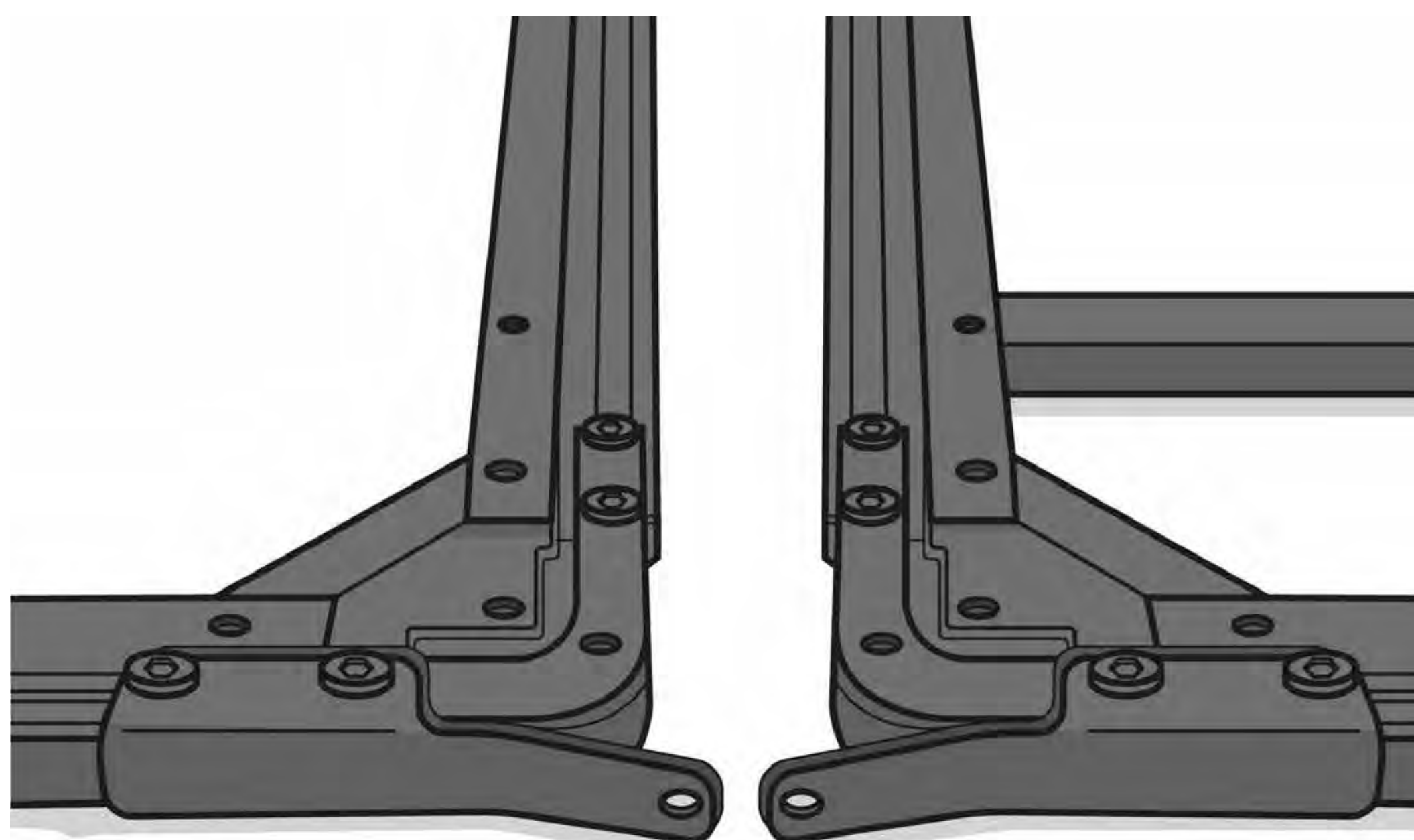
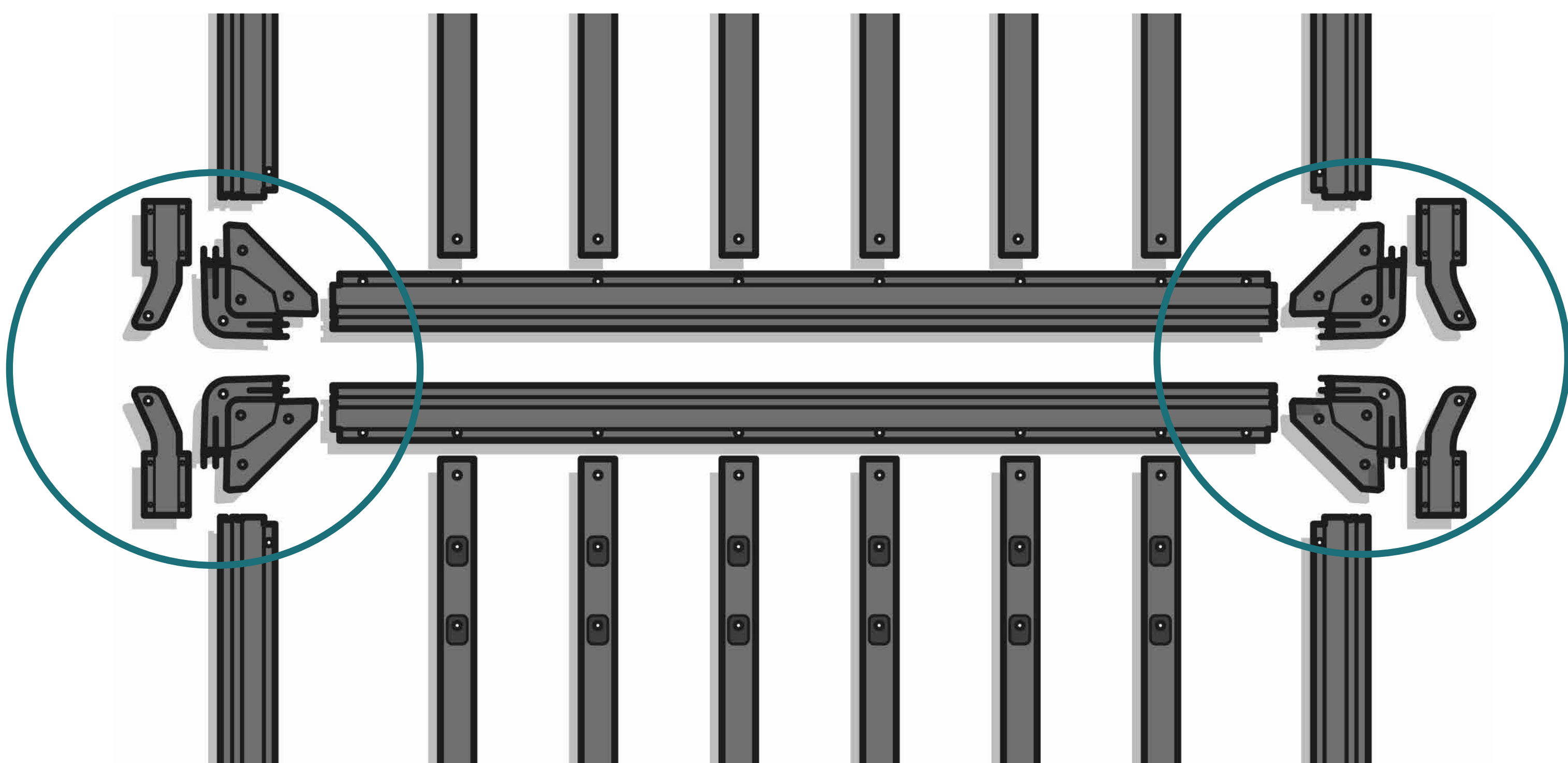



- Push plastic corner piece in to outer profile and center profile.

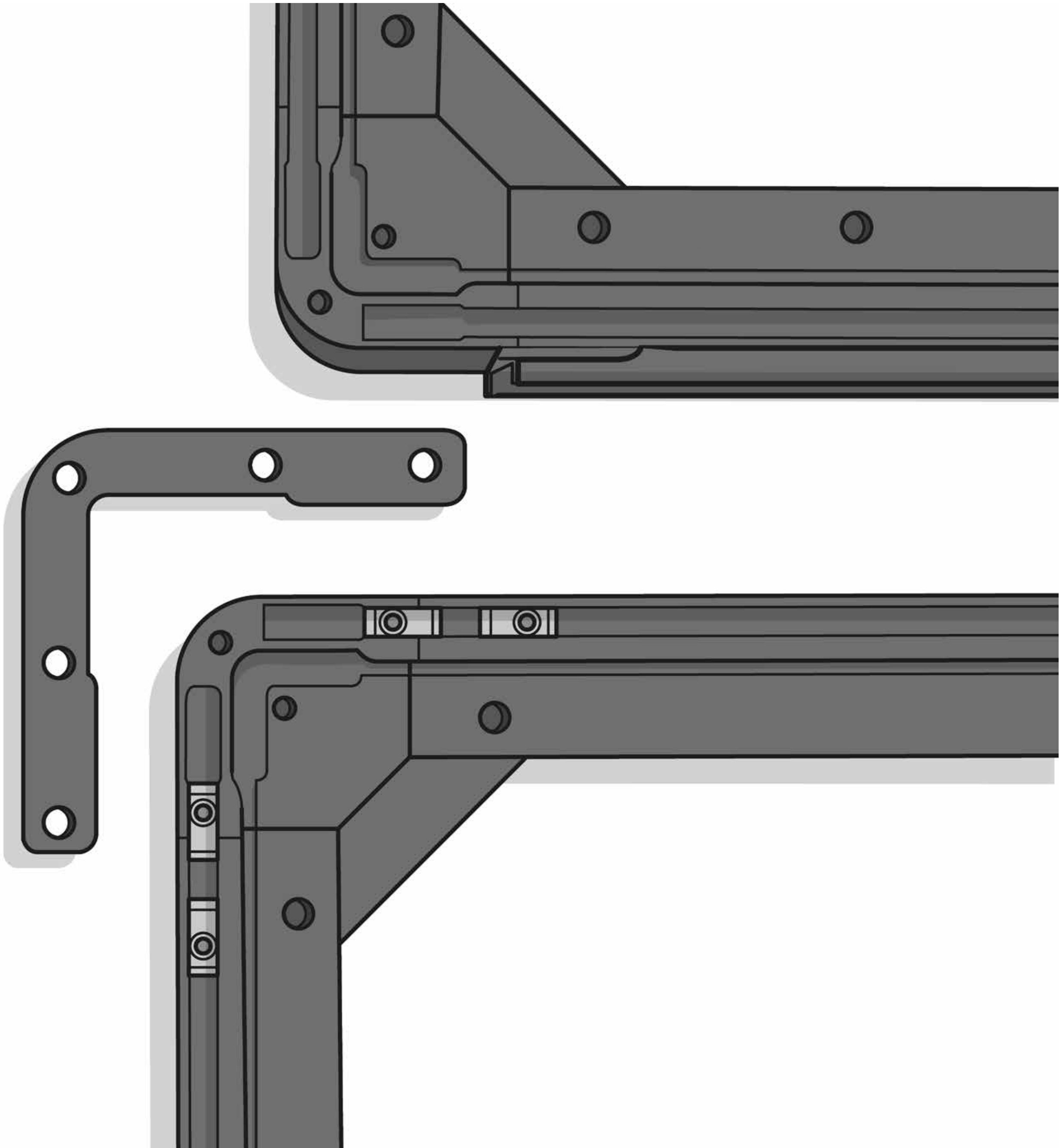

- Insert 2 slider nuts (**packet A**) in each profile channel. Match nut direction to image above.

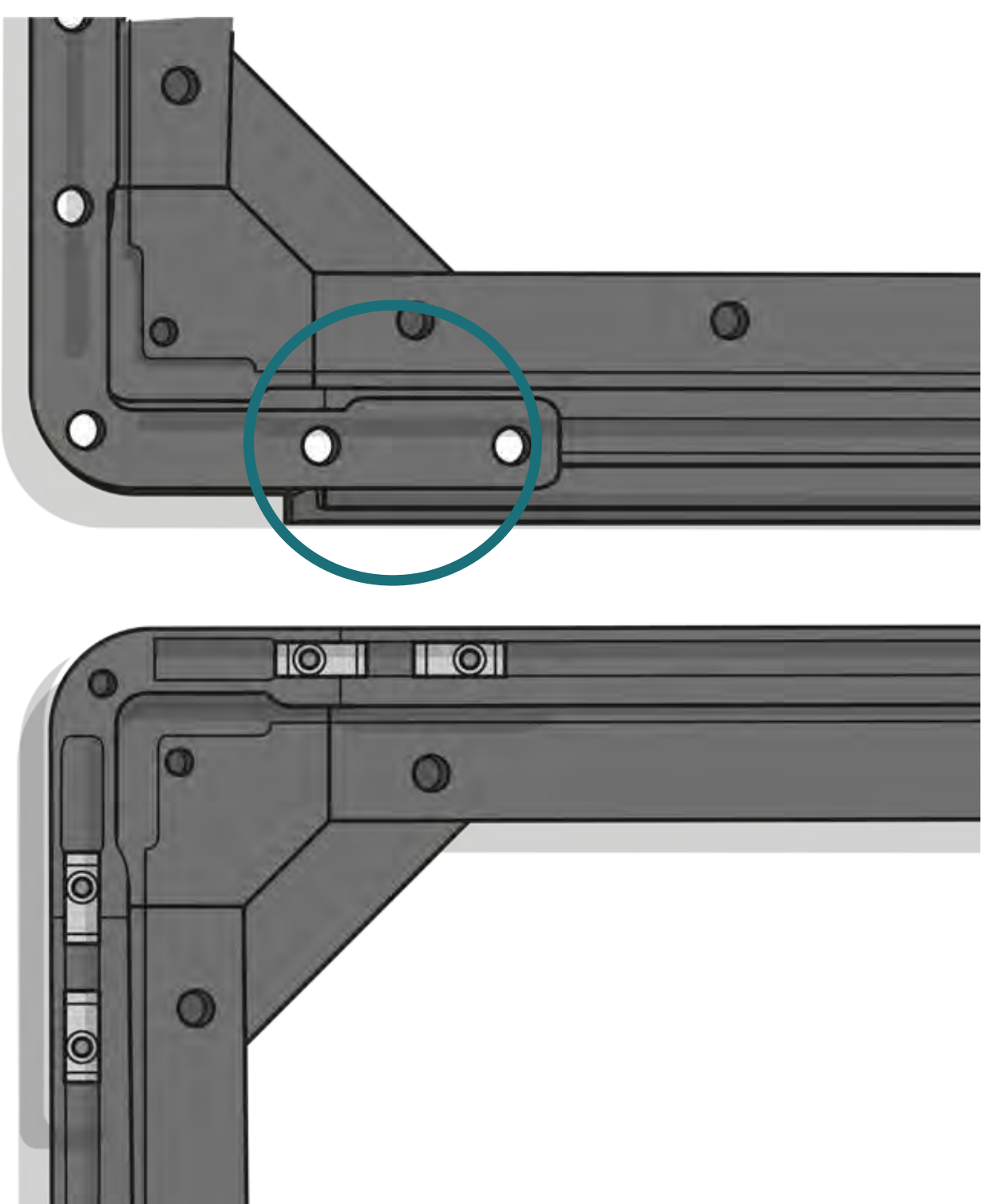

- On the center profiles, secure narrow metal corner bracket with the shorter bolts (**packet B**) and spring washers (**packet C**).

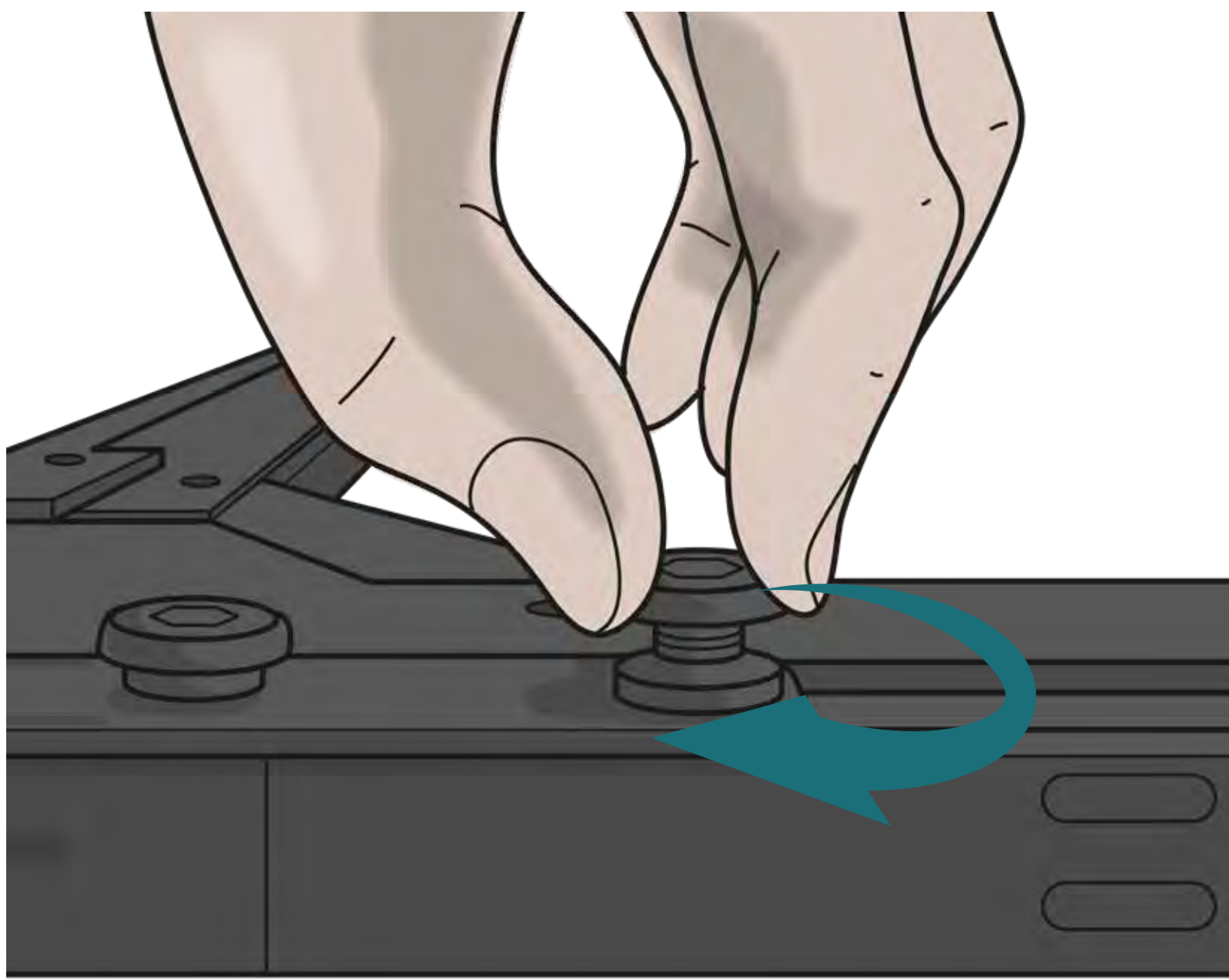

! Do not over tighten! Keep a wee bit loose. You'll do a final tightening pass later.

- Identify and pair up the correct hinges.

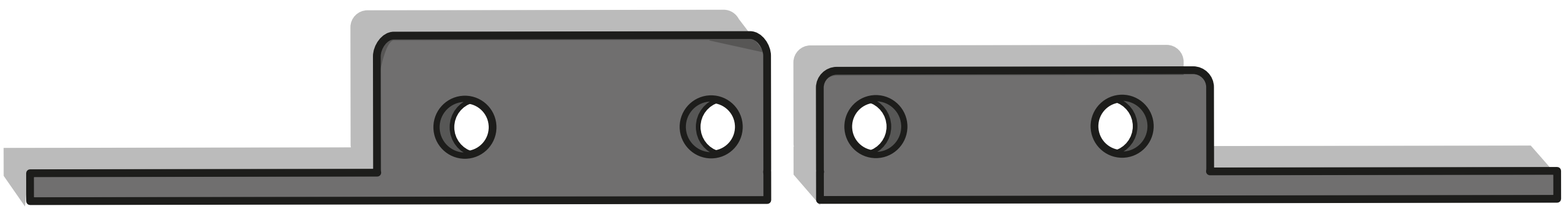

i There are 2 style hinges. 1 is a bit wider. 1 is narrower.

- On the outer profiles, use the longer bolts (packet D) and spring washers (packet C) to secure the hinge plate bracket on top of the narrow corner bracket.

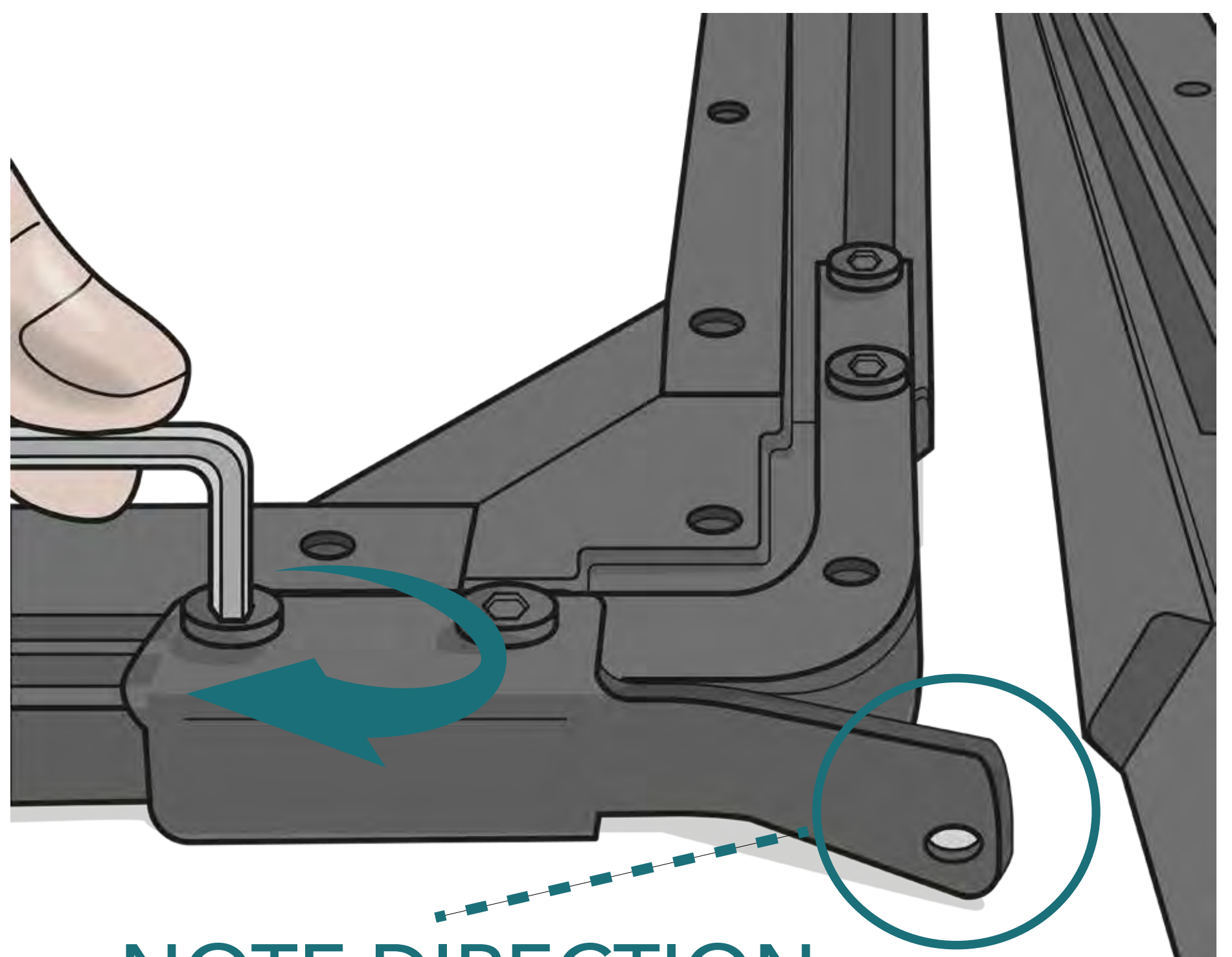

NOTE DIRECTION



i Pair a narrow hinge with a wide hinge. Place a wide hinge and narrow hinge on one platform half. On the 2nd platform half, place the wide hinge opposite the narrow hinge on the 1st platform half.

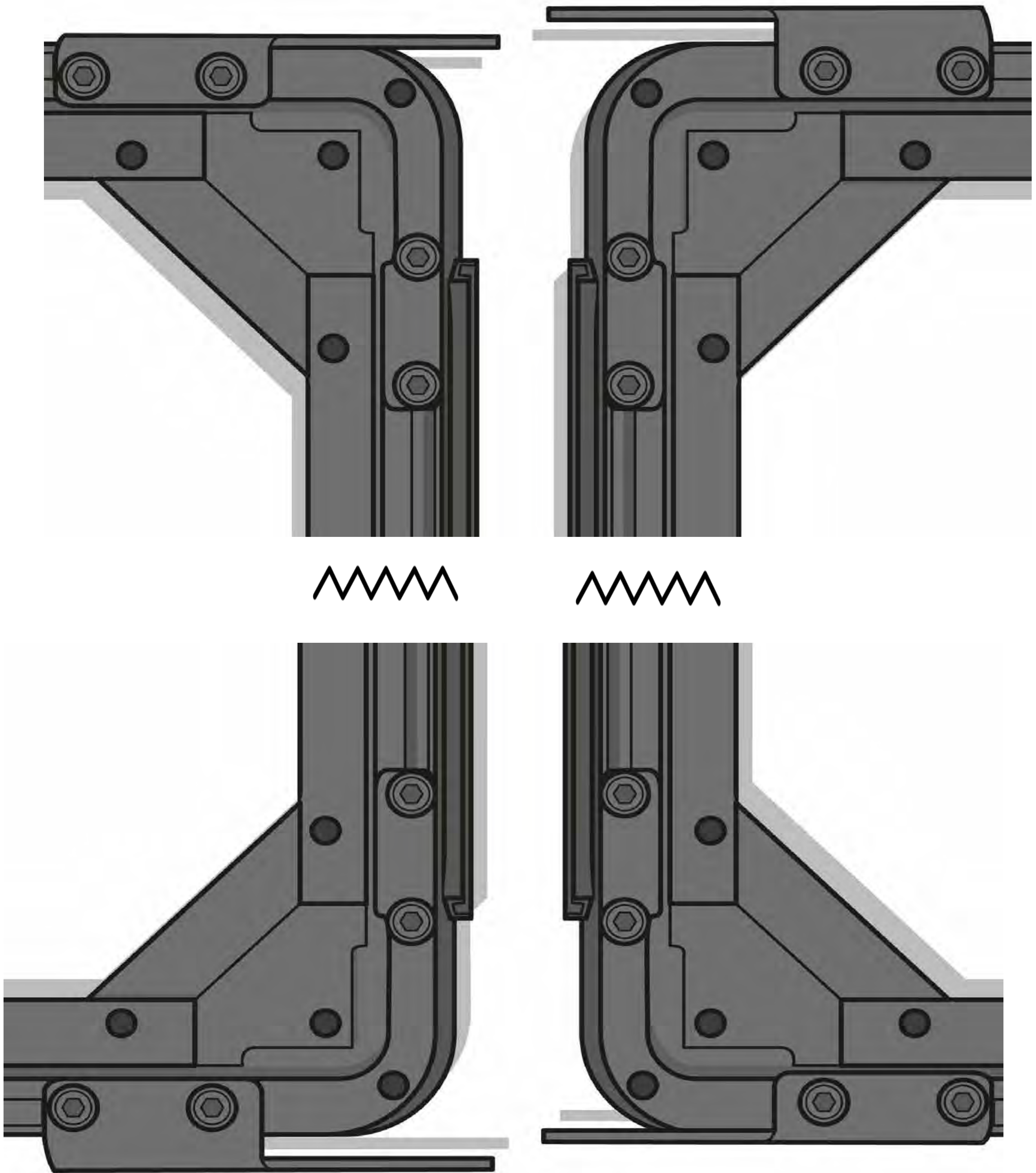

- Complete this step and fasten hinges and brackets for the remaining 3 center corners.

Don't get ahead of yourself. Do not bolt the hinges together yet. We will attach the platforms to each other at a later step!



INSTALL PLATFORM SLATS

SUMMARY Use the sleeve nuts and bolts (packet E) to fasten the slats to the outer and center profiles. The track slats have 6 holes. These track slats are for attaching the tracks that will be used to secure the Rev Platform to your cross bars or roof rack. These track mounting slats all go on one platform half. The standard slats with 2 holes are grouped together on the other platform half.

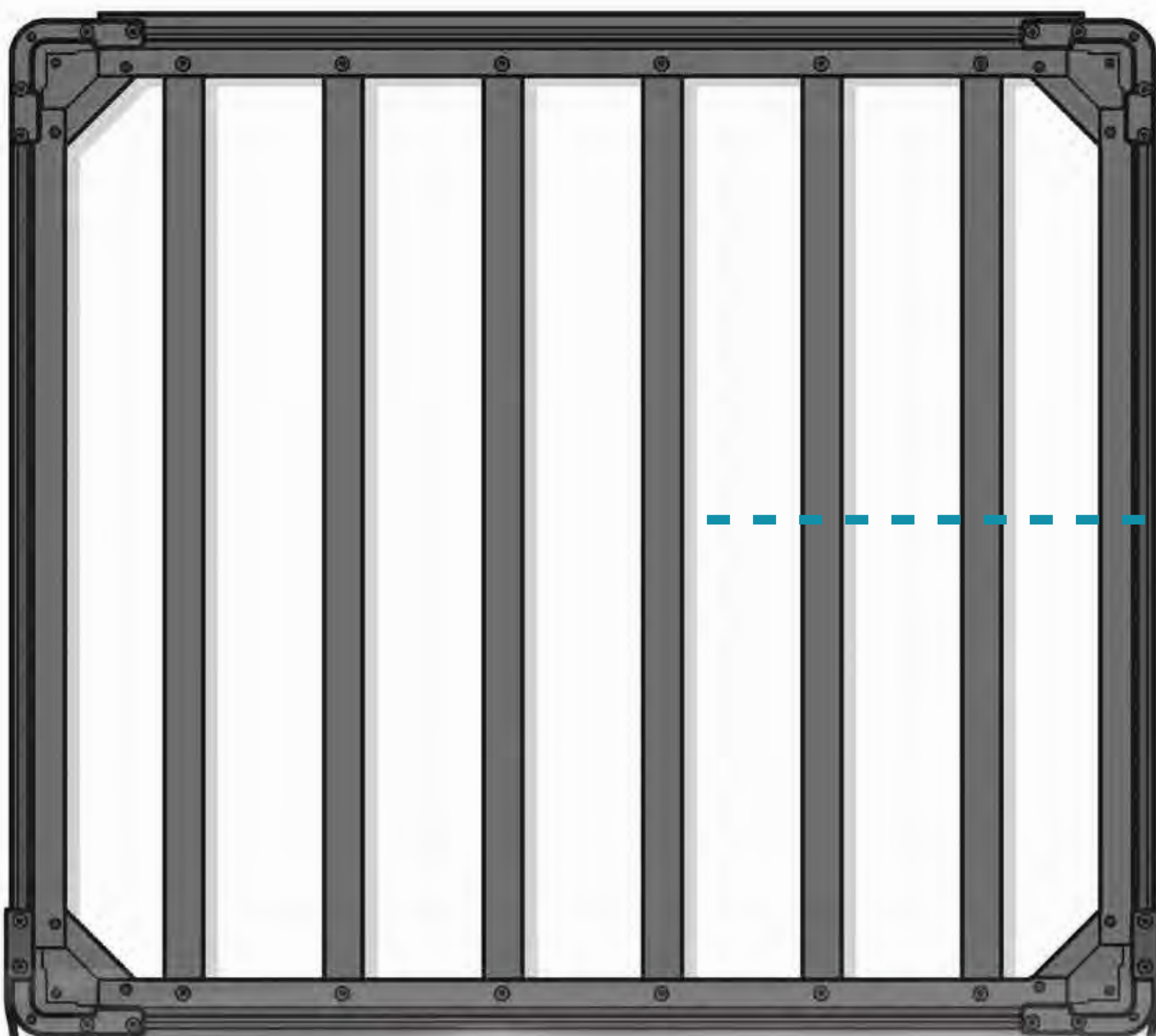

Standard Slats

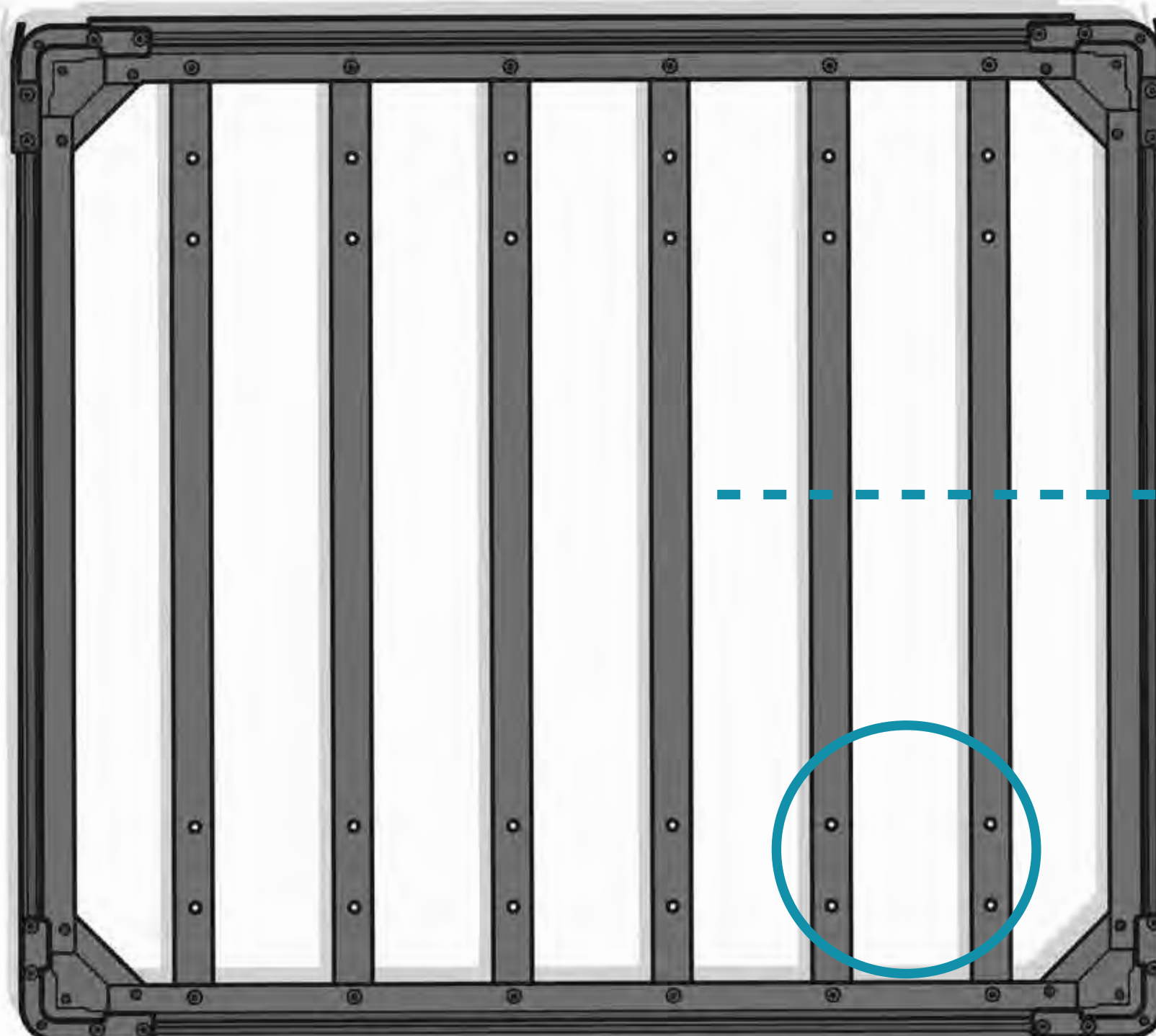

Track Slats



- Install track slats. These track slats have 6 holes in them. These are all grouped together on one side of the platform.

The holes must face up, the cut out openings face down.

Use the sleeve nuts and bolts ([packet E](#)) to attach the slats to the center and outer profiles.

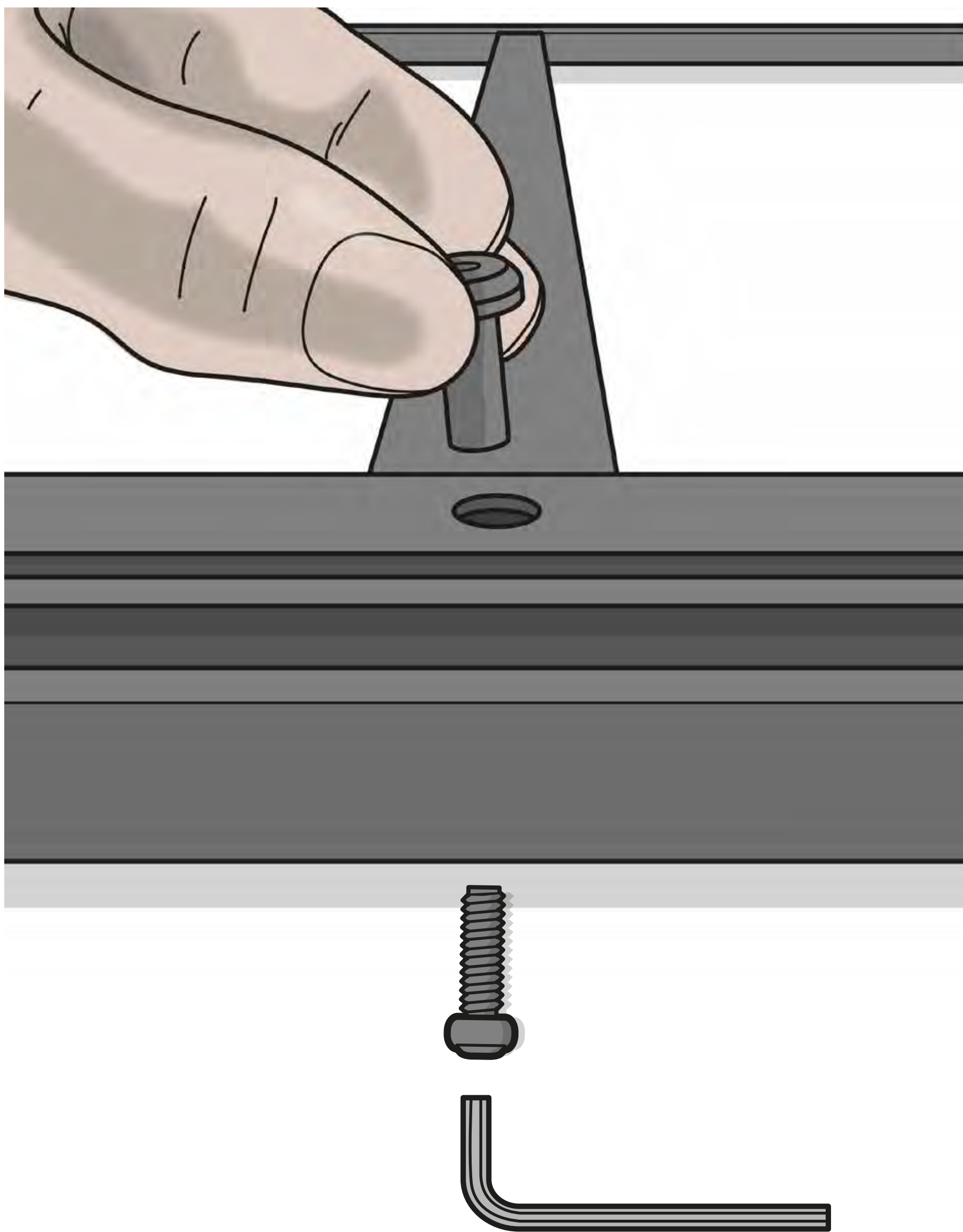

Use 2 hex keys to tighten. Do not overtighten.

i Angle the slats to fit them in. You may have to stand the Rev Platform halves on their sides to properly seat and line up the holes



- Install standard slats. The standard slats have 2 holes in them. These are all grouped together on one side of the platform.

Remember to only slightly tighten. You will do a full hardcore tightening pass soon. Promise!

- Once all slats are bolted in, **turn each platform half over.** You are now looking at the **TOP SIDE** of the Rev Platform.

Getting there!



ASSEMBLE OUTER CORNERS & TOP BRACKETS

SUMMARY With the platform halves turned over, you are now looking at the top of the platform. It's time to install the top brackets on all the OUTER corners using the shorter bolts (**packet B**), spring washers (**packet C**) and slider nuts (**packet A**). Each top bracket also uses 2 sleeve nuts and bolts (**packet E**).

 A friendly reminder: the outer corners are ones that do not have hinges!

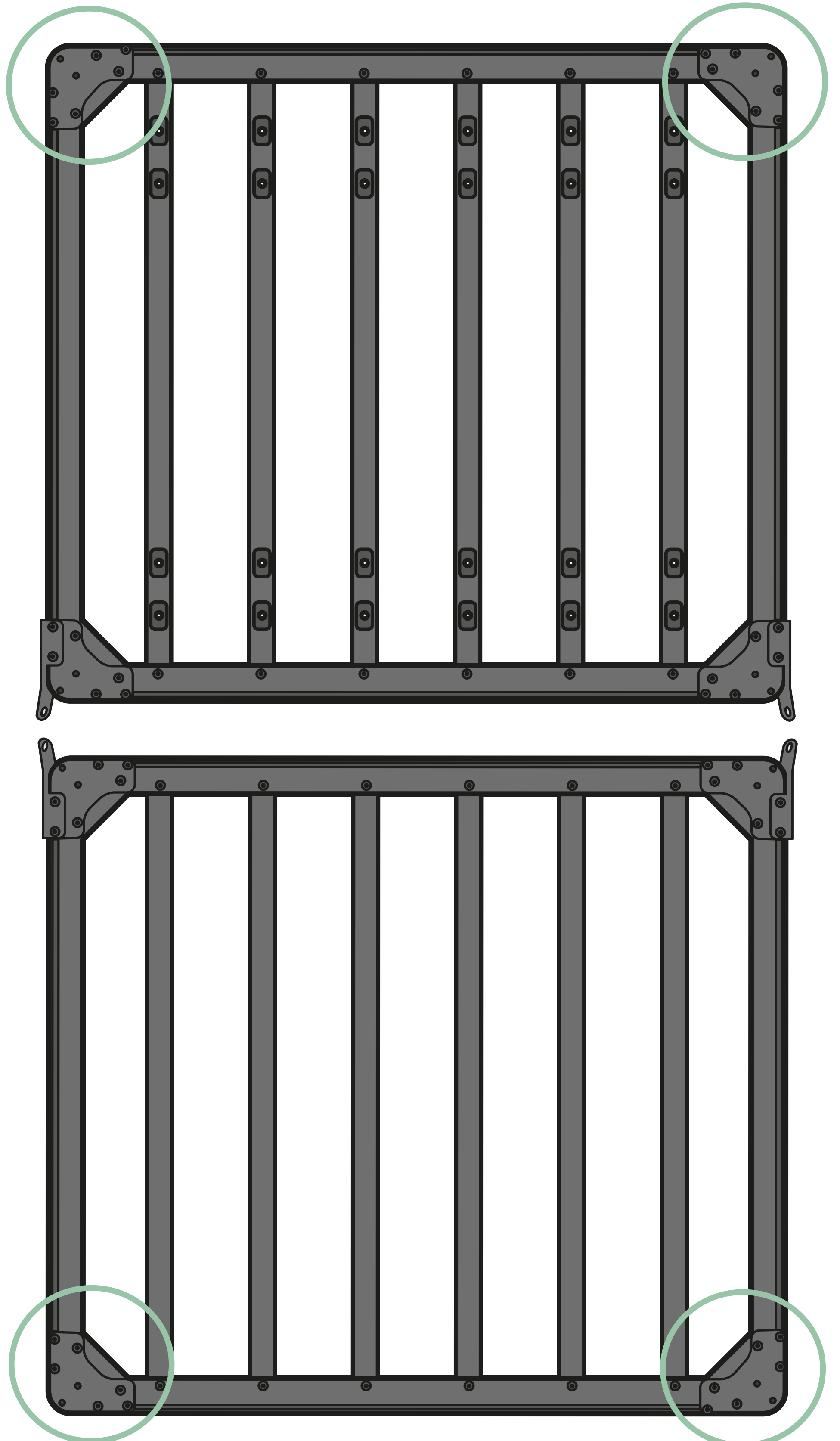

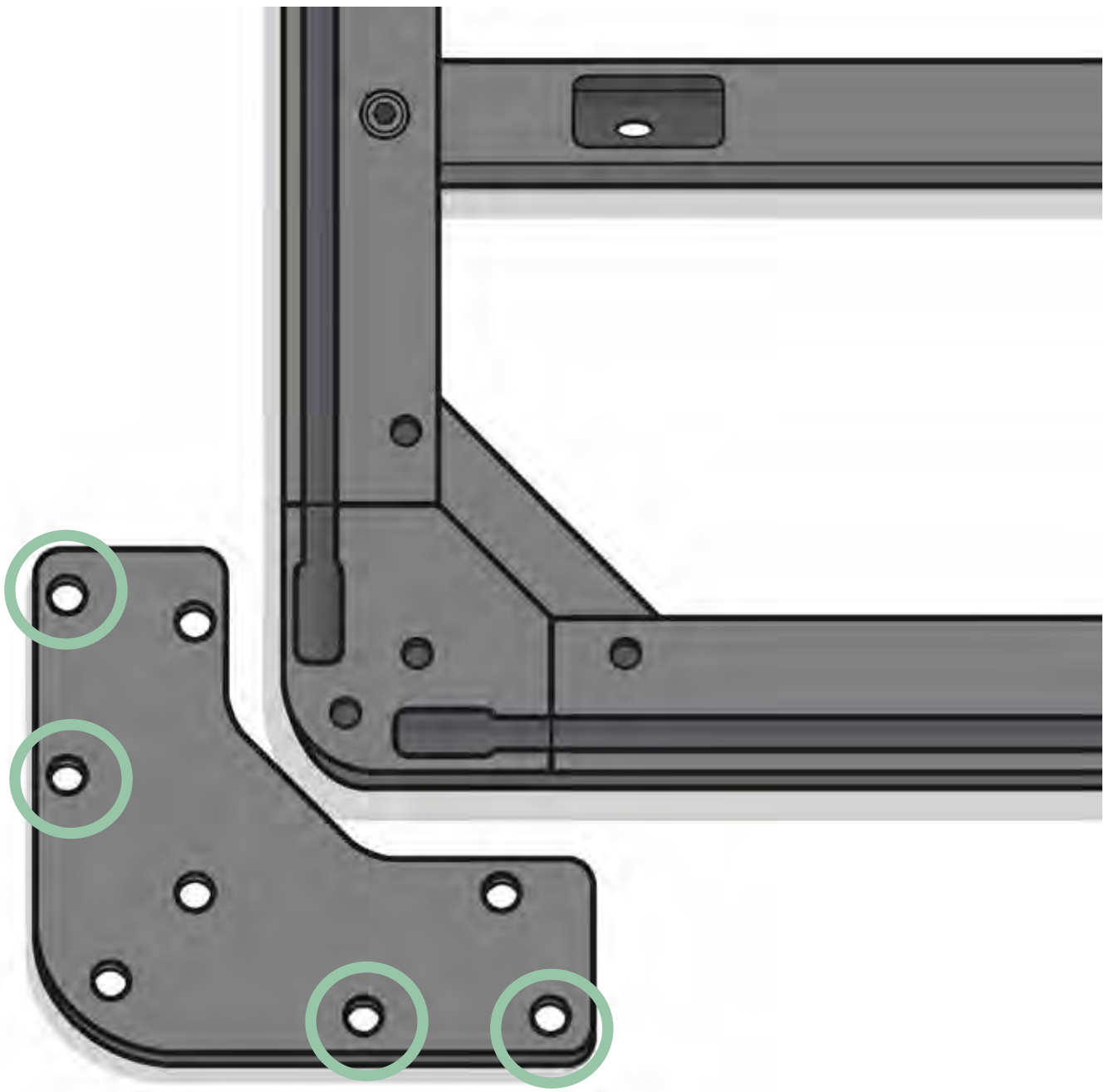

- Gather the top brackets. You'll be using the same mounting points as with the narrower bottom brackets from the earlier step.

- Insert 2 slider nuts (**packet A**) in each corner channel. Line up the slider nuts with the holes in the brackets.

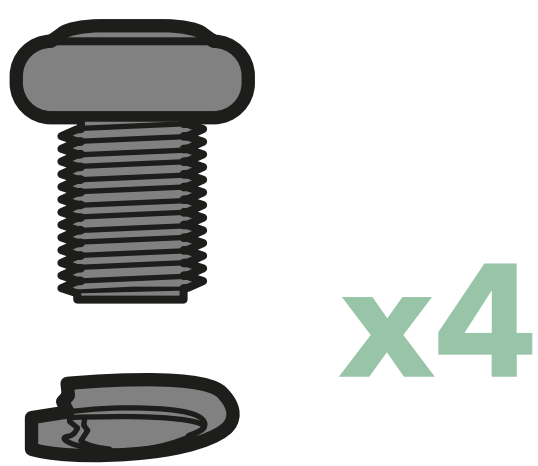
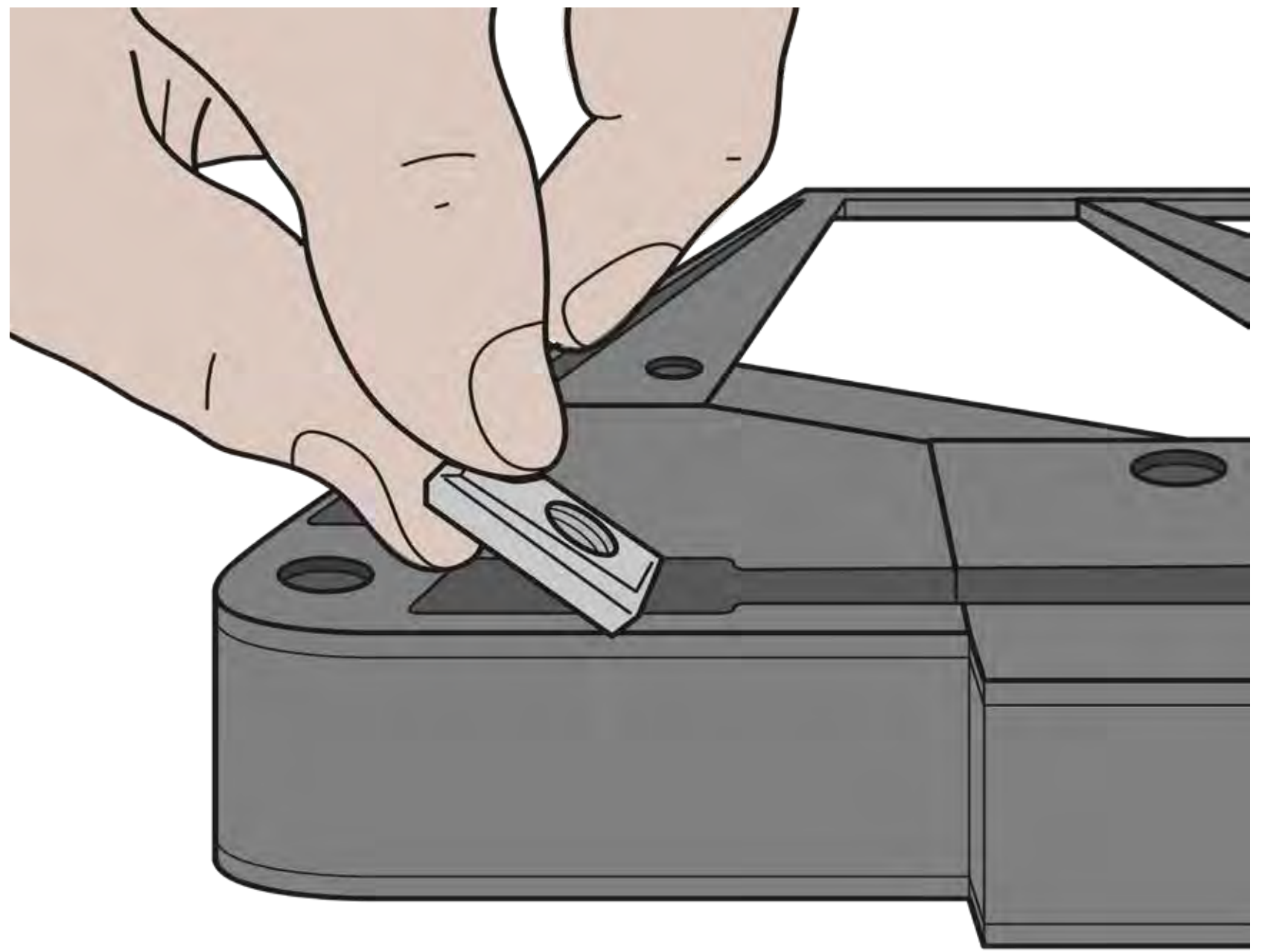

- Screw in the shorter bolts (**packet B**) with spring washers (**packet C**) in the 4 positions. Half turn only! We'll do the full tighten at a later step.

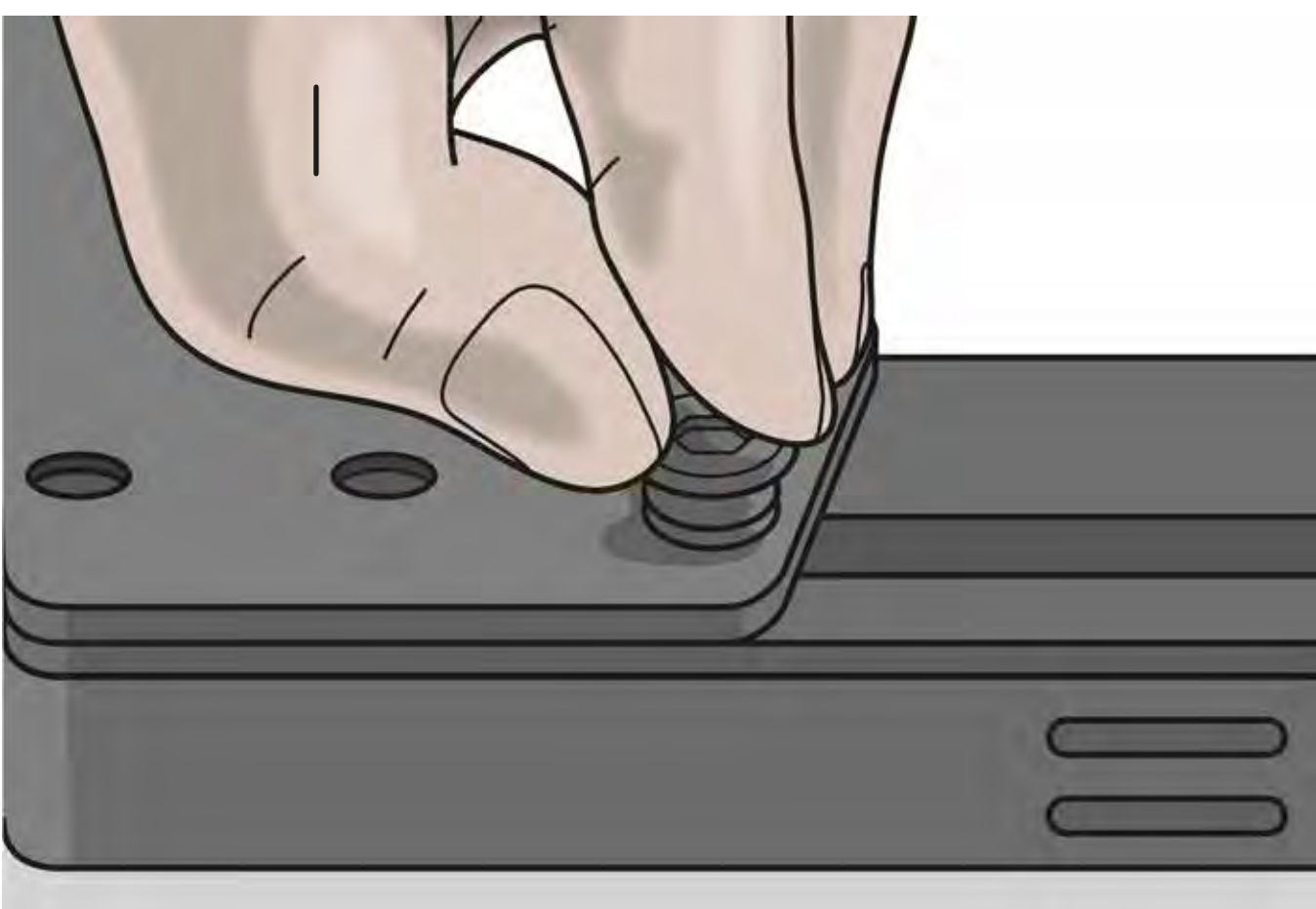

i If the slider nuts don't line up perfectly, you can always nudge them into better position with a hex key.



- There are 2 additional connection points. Use the same sleeve nut and bolt used to secure the slats (**Packet E**).

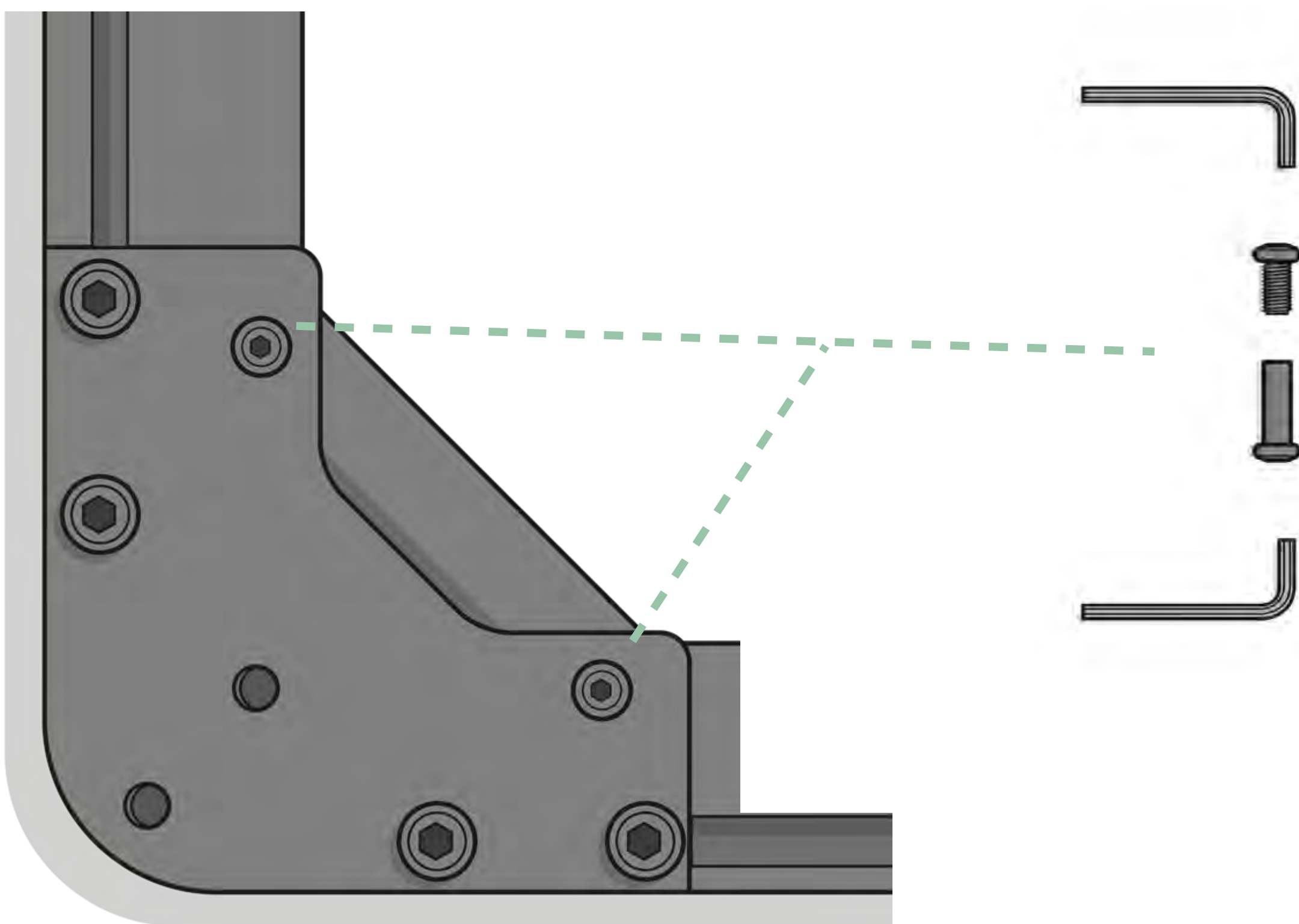
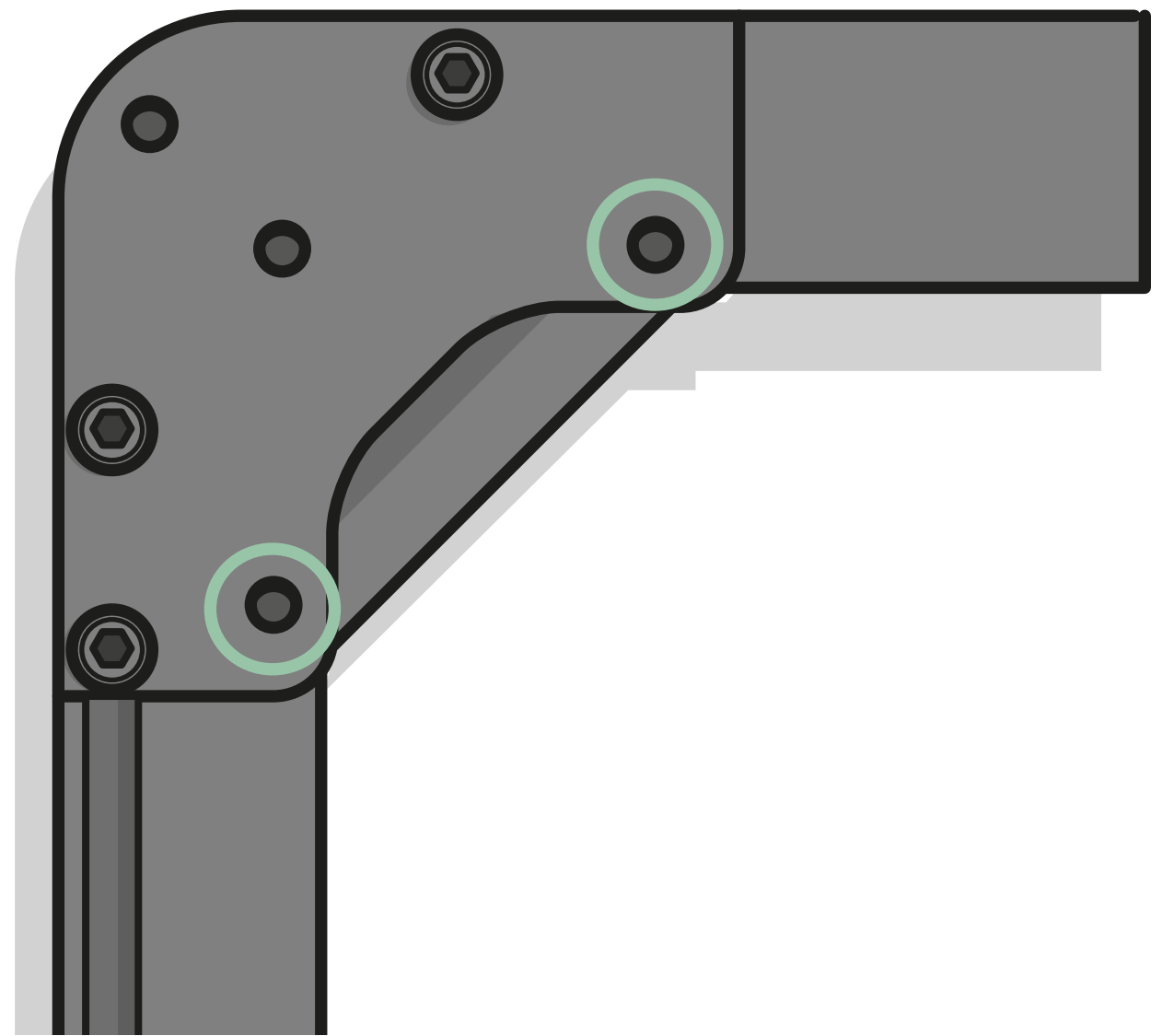

Do not fully tighten. We'll get to that step. Promise!

i These holes may not be perfectly aligned. This is the reason you haven't fully tightened every corner yet. If you need to carefully and forcefully adjust the corners and profiles to get the sleeve nut to drop in - do it! No one's judging. If you have a rubber mallet or a hammer with a soft cloth to protect the platform, you may need to lightly tap on the outer profiles to adjust.

- Repeat this step and fasten the top corner brackets to the the additional 3 outer corners.



ASSEMBLE CENTER CORNERS, TOP BRACKETS & HINGES

SUMMARY It's time to attach the corner top brackets to the center corners. The shorter bolts (**packet B**) and spring washers (**packet C**) are used to secure the corner top brackets to the center profiles. The longer bolts (**packet D**) and spring washers (**packet C**) are used on the outer profile hinge side. And just like the outer top corners, there are 2 sleeve nuts and bolts that are used to secure the profiles to the brackets (**packet E**).

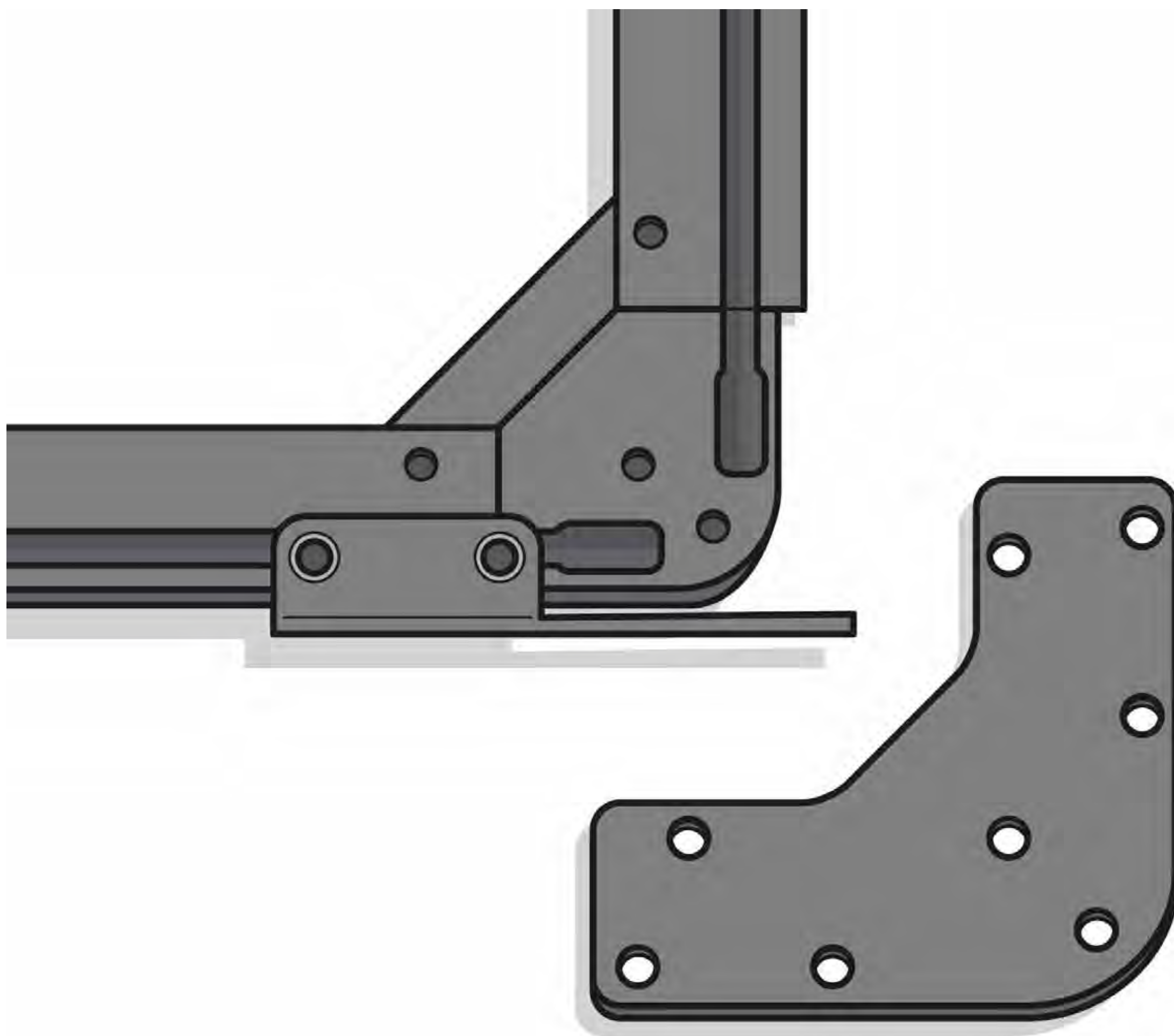



- Insert in the slider nuts ([packet A](#)). 2 per channel. You can drop them in using the channel slot in the corners or the channel slot in the profiles.

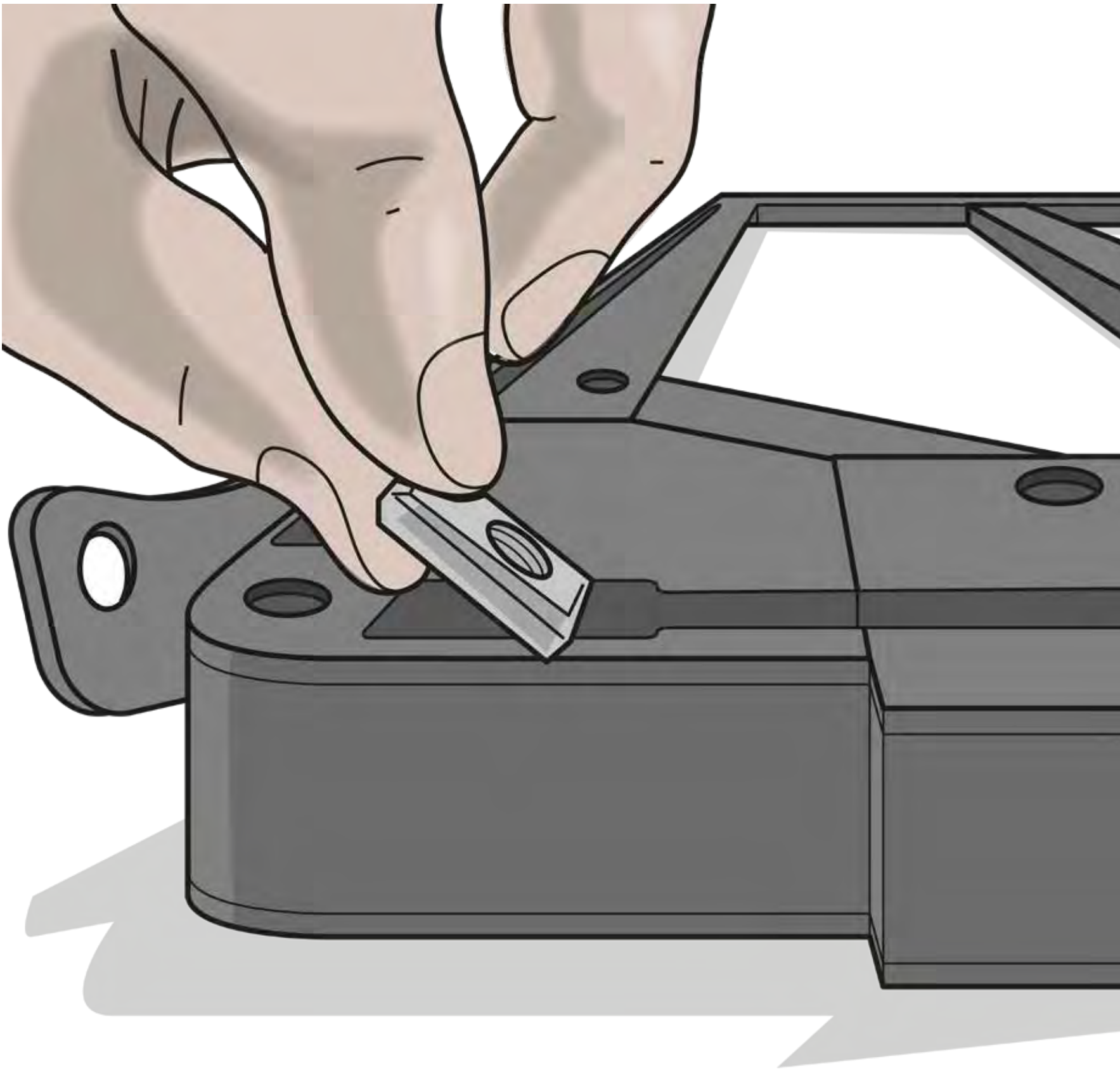

OR

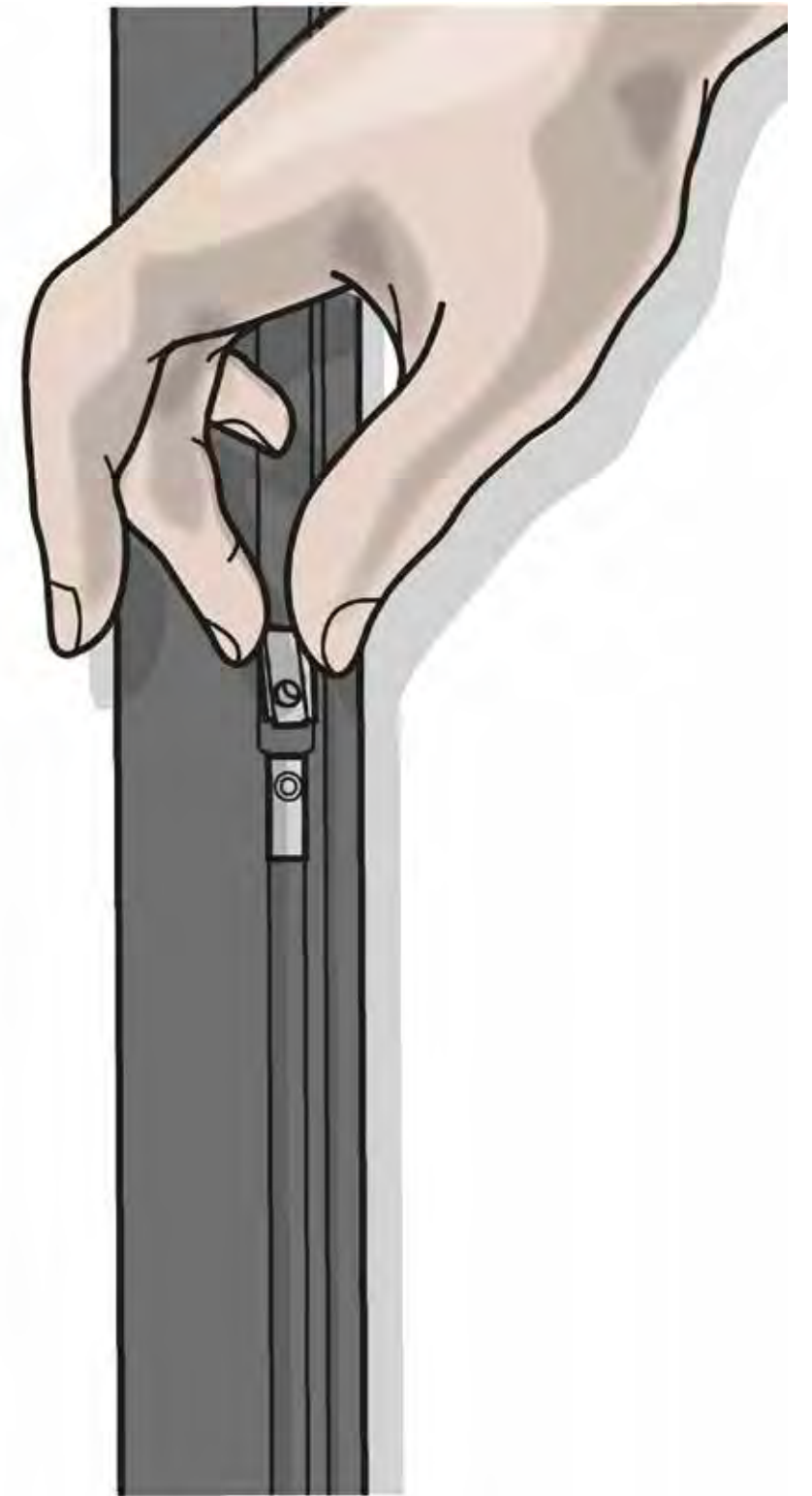

i To adjust the slider nuts to line up exactly with the bracket and hinge holes you can get in there and do some fine tuning with a hex key.

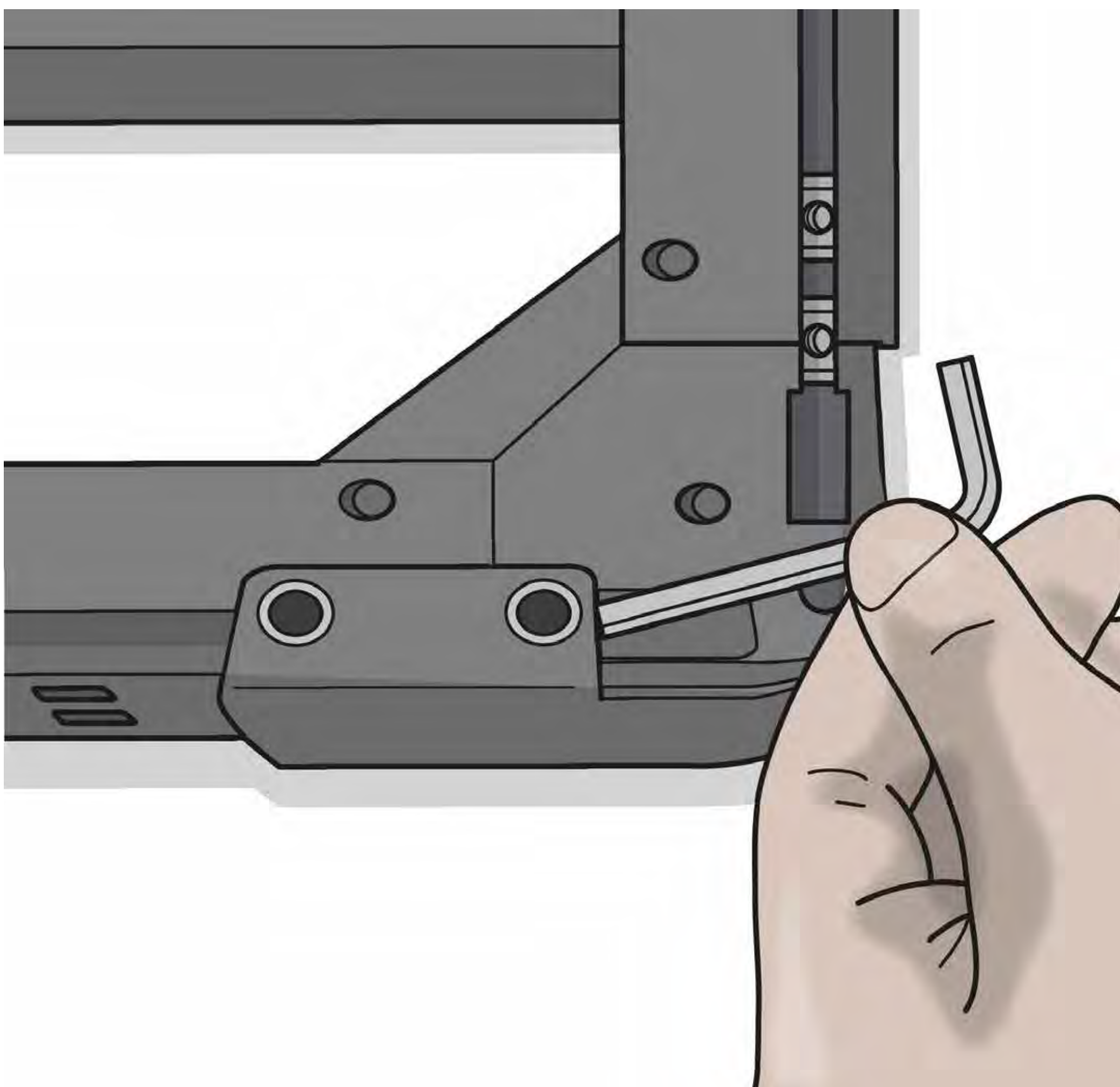



- Place the corner top bracket in position - slide underneath the hinge. On the center profile with the holes and no hinge, secure using the shorter bolts (packet B) with spring washers (packet C).

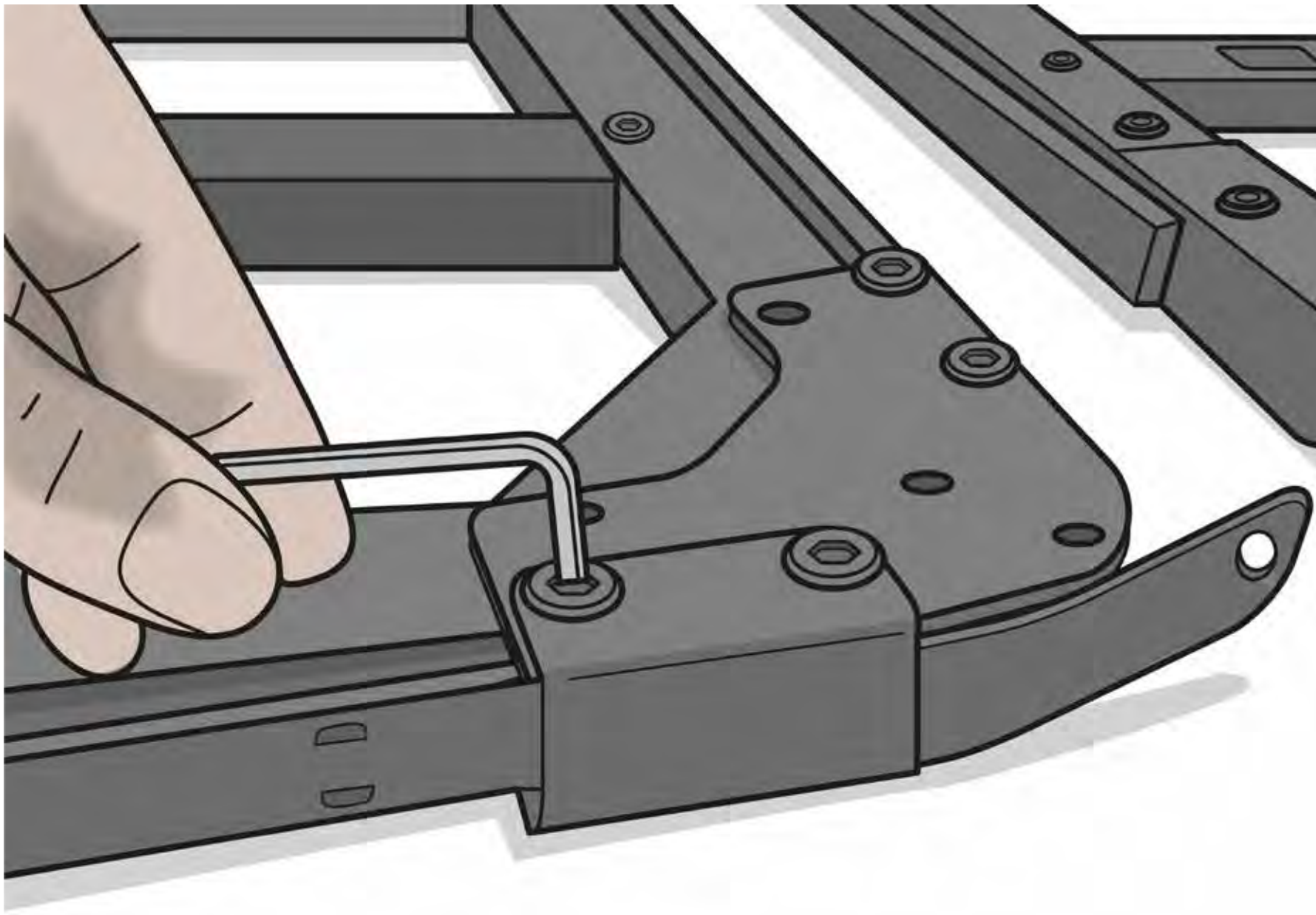

- To secure the bracket and hinge to the platform, use the longer bolts (packet D) with the spring washers (packet C).

! Do not fully tighten! You need a bit of relief to line up the holes in this next step.

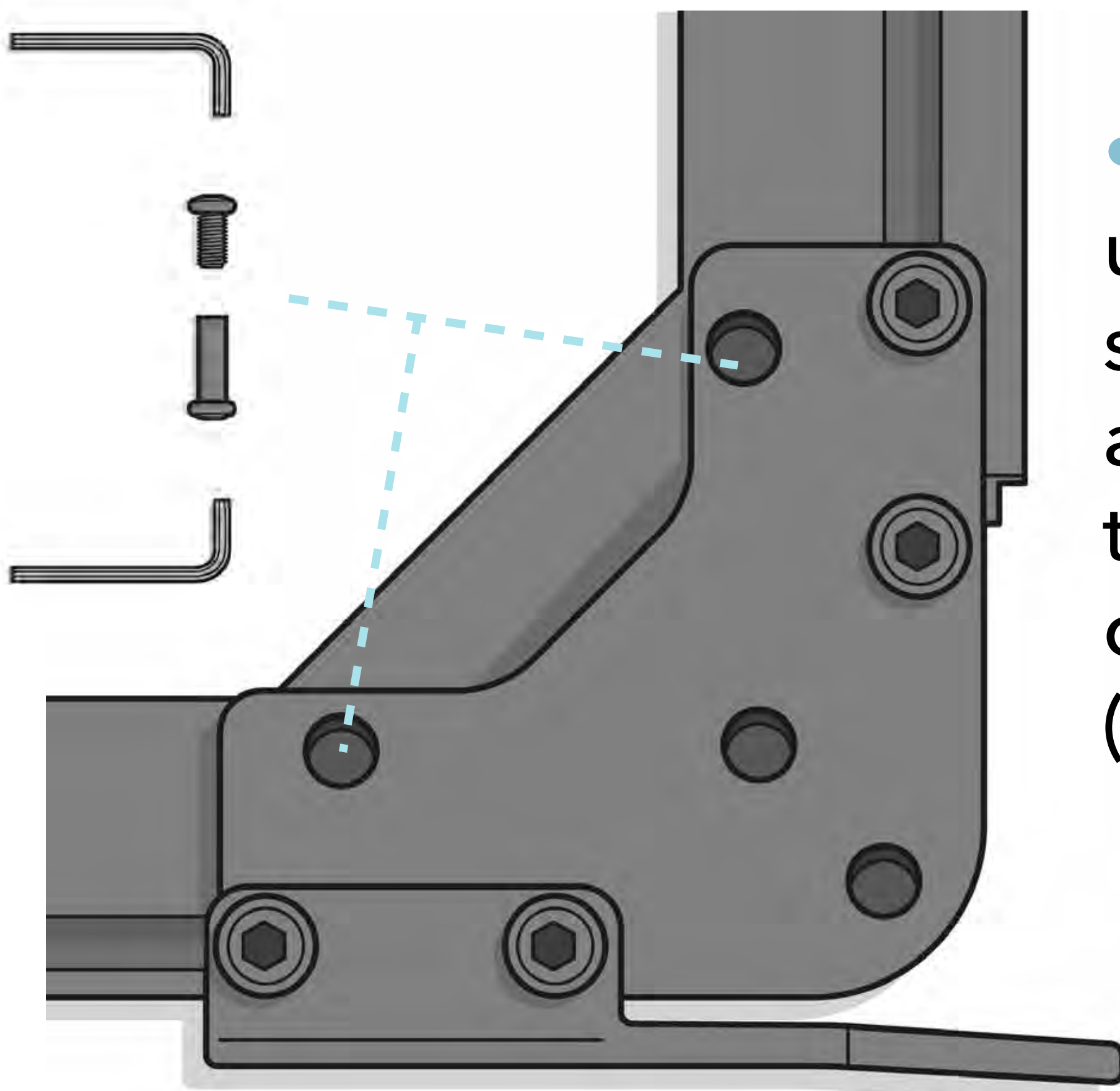

- And finally, use the same sleeve nuts and bolts for the final 2 connections (Packet E).

i If the sleeve nuts don't drop in, you may need to adjust the angle of the profiles.



- Now install the corner top brackets to the remaining 3 center corners.

Shew. The corner top and bottom brackets are assembled. The slats are in place. Look at how far you've come!

STOP. TAKE A BREAK. BREATHE.

You are way more than halfway done.

Preview of what's to come: You still have to tighten the bolts, add the tracks, add the hardware for the ladder and install the latches to lock the platform closed.

Grab a snack. Pet your dog. These instructions can wait.



THE MOST IMPORTANT STEP EVER!

SUMMARY Tighten all the corner bolts and slat bolts on both sides of each platform tray. Use the hex keys and lean in to it. Get them TIGHT!

- Remember where you start. Do one side at a time. Move clockwise.
- Be sure to use both hex keys on all the slats and top corner brackets.
- Once you have gone all the way around each side of each tray - go around again. Make sure you didn't miss any. This is the most annoying yet important step you will ever do in your life! Really.



WARNING

Regularly check nut and bolt connections. Retighten if needed.



ADD TRACKS TO BOTTOM OF TRACK SLATS

SUMMARY Choose the position and bolt on the tracks with the hardware in **packet F**.

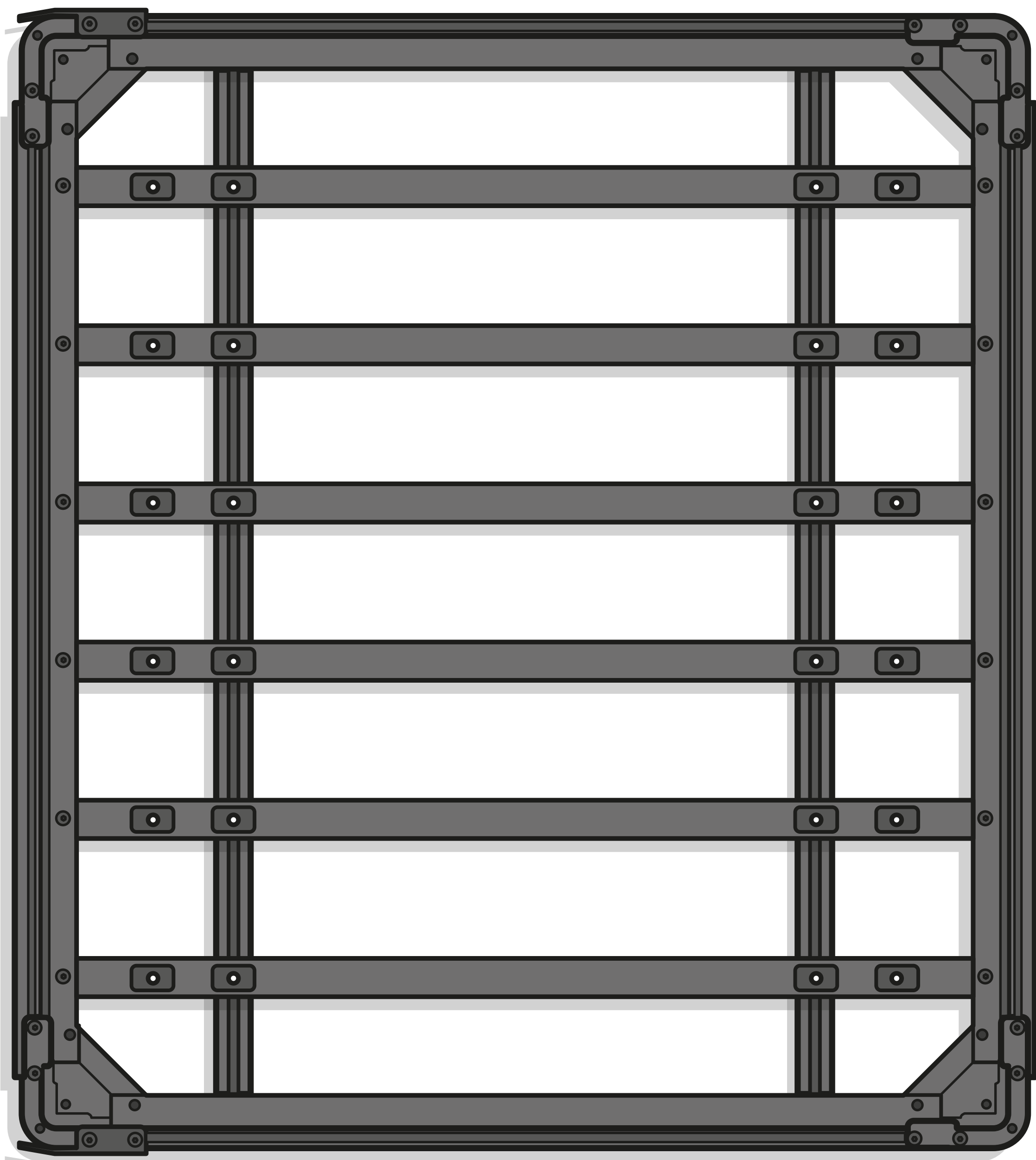



- Center the square tracks underneath the track slats.

Depending on the length of your cross bars you may choose to mount the cross bars in the inner narrower position. If your cross bars or rack slats are long enough, use the wider / outer position. It's easier to access the mounting brackets when the tracks are closer to the edges of the platform.

- Adjust slider nuts (pre-installed on track) to line up with the track slat holes.

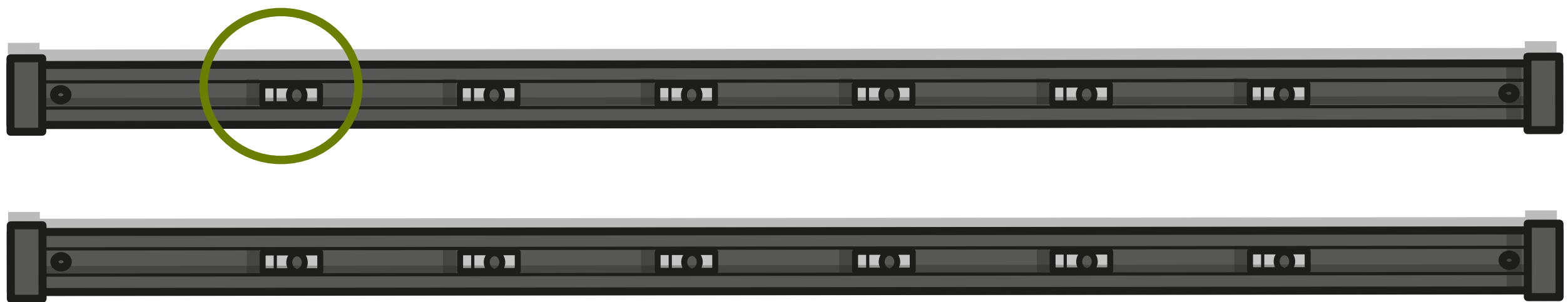

- Bolt together using the hardware in **Packet F**. Follow placement of spring washer and standard washer.

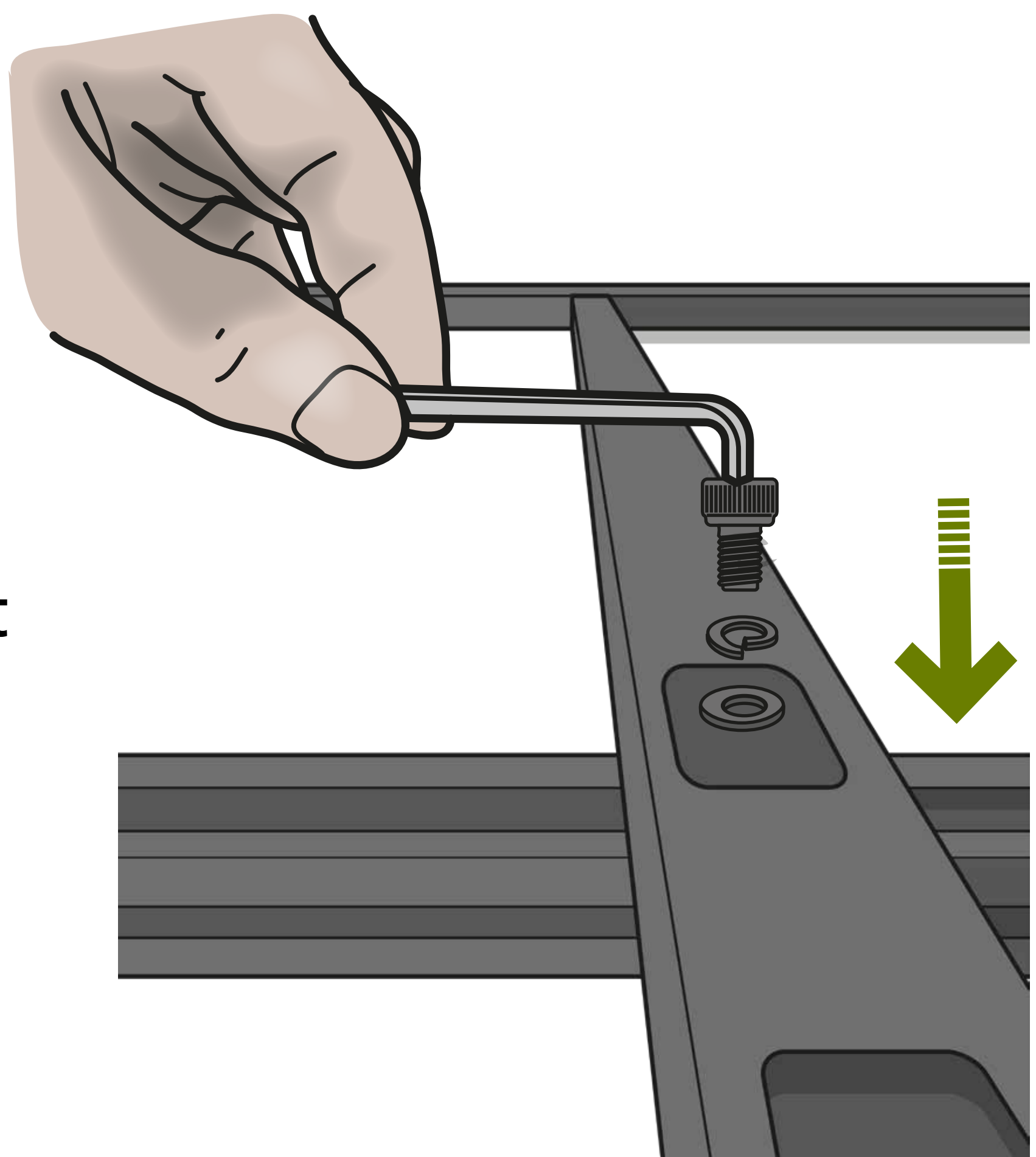

i You may need to put a knee on the platform to push it closer to the track. Put pressure on the hex key as you turn to force that spring washer down to allow the bolt to reach the threads in the slider nut below.



SLIDE IN STOPPERS

SUMMARY Slide the stoppers (**Packet J**) in the outer profile channel of the bottom platform (the platform half with the tracks). Position them at the end of the first inside slat.

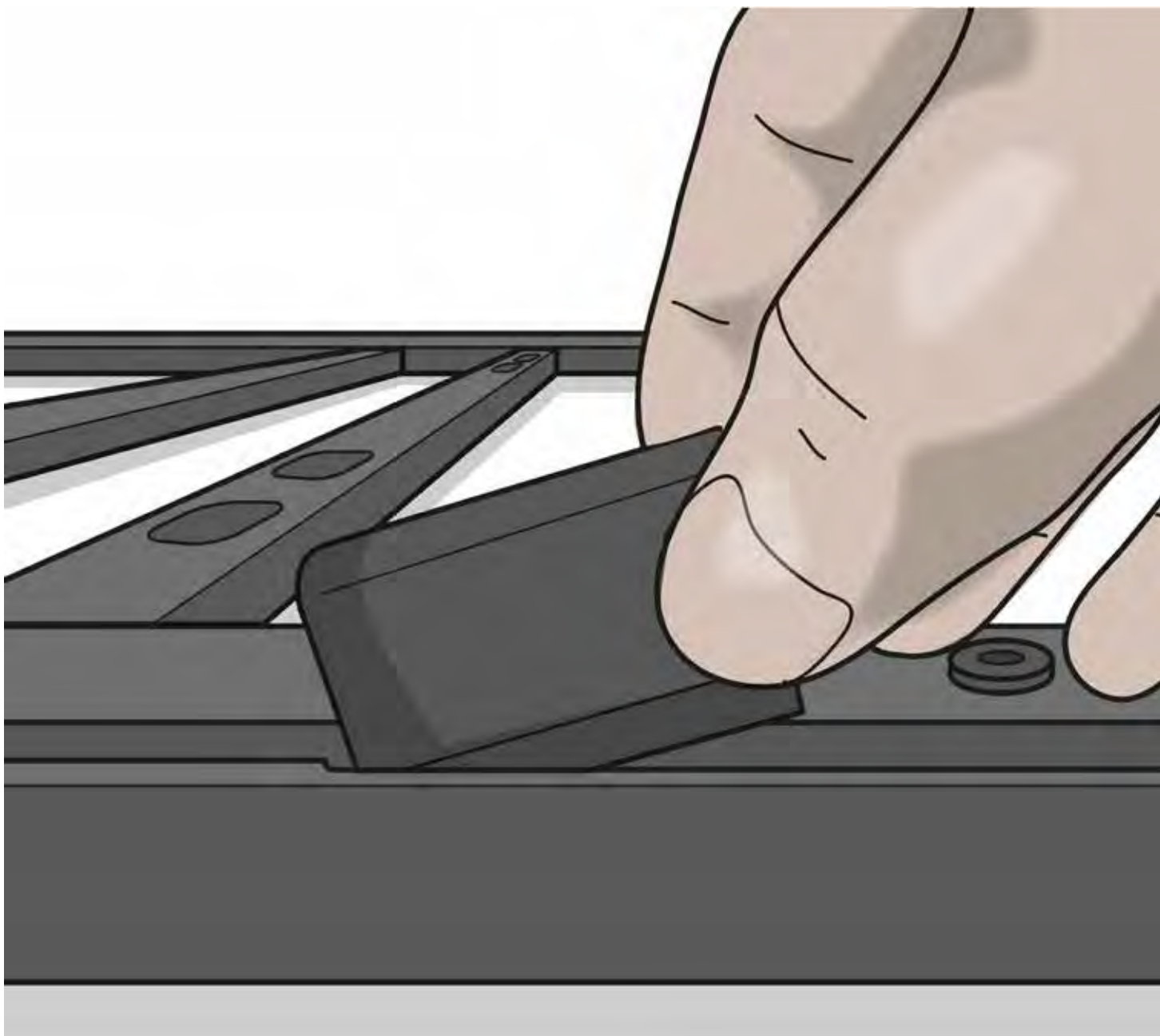
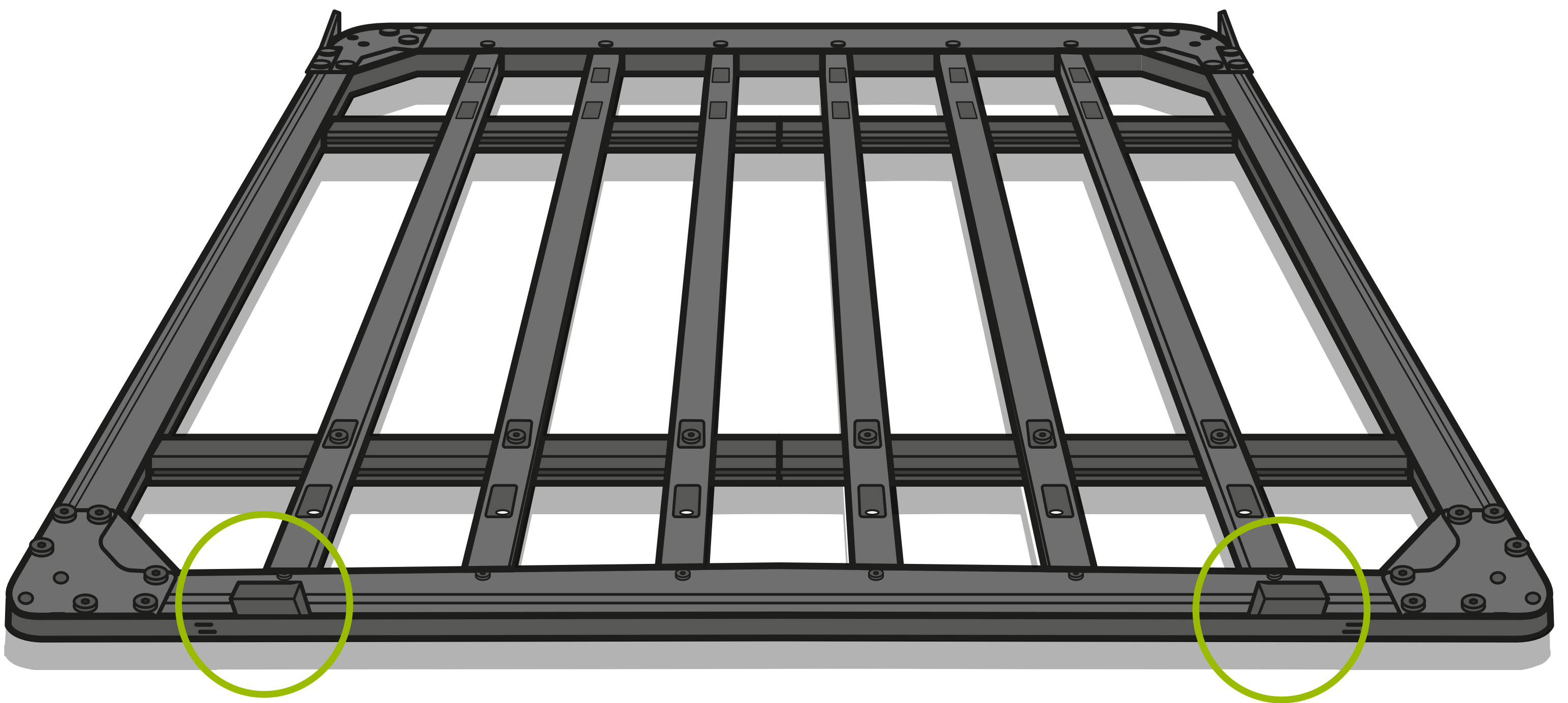

- Drop both stoppers (**packet J**) in the center channel slot and slide in to position.

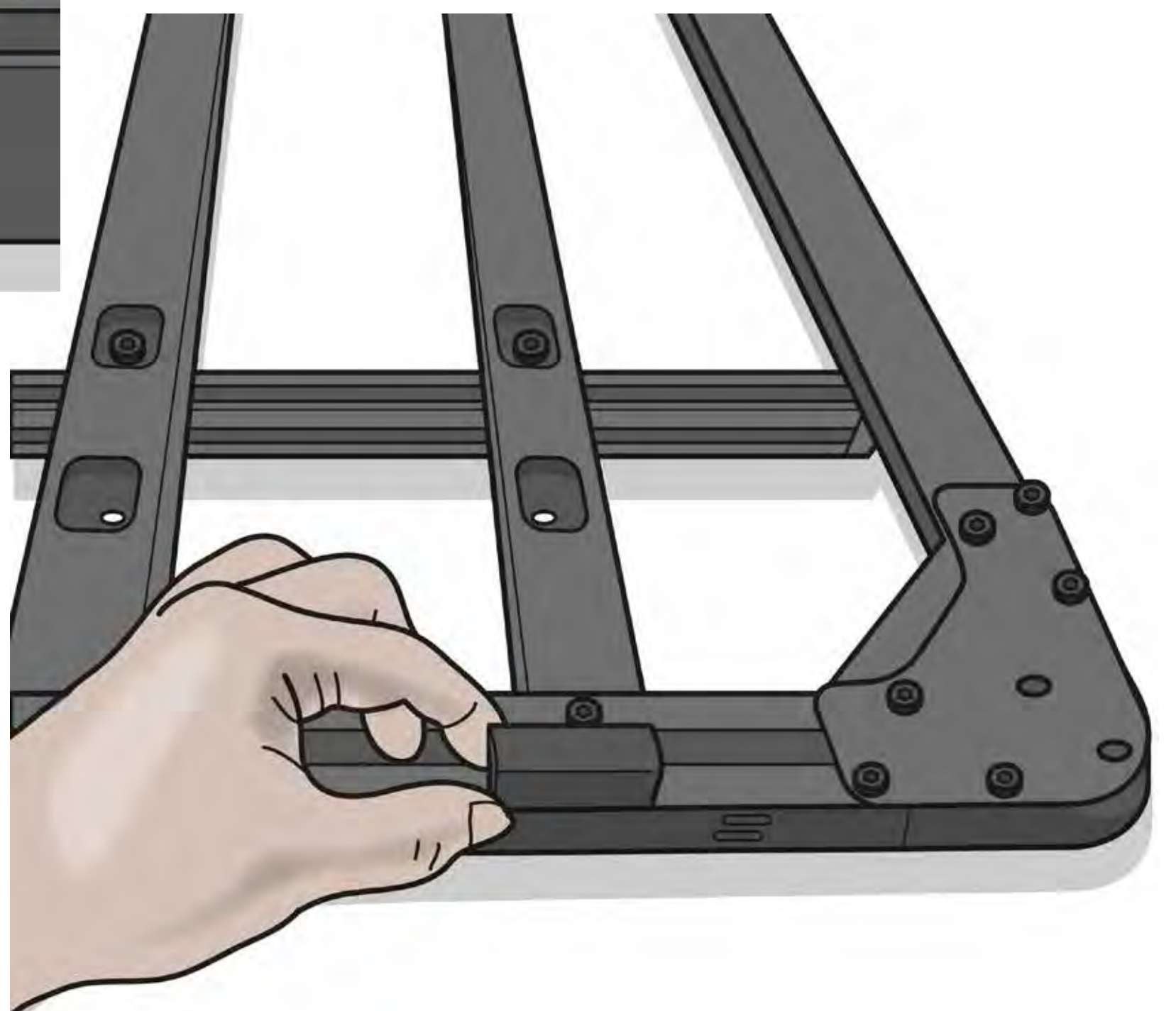



BOLT TOGETHER HINGES

SUMMARY Use the hardware from **packet G** to bolt the hinges together.

- Line up the platforms. The narrow hinge should sit just inside the wider hinge. Position bolt, washers, nut as pictured.

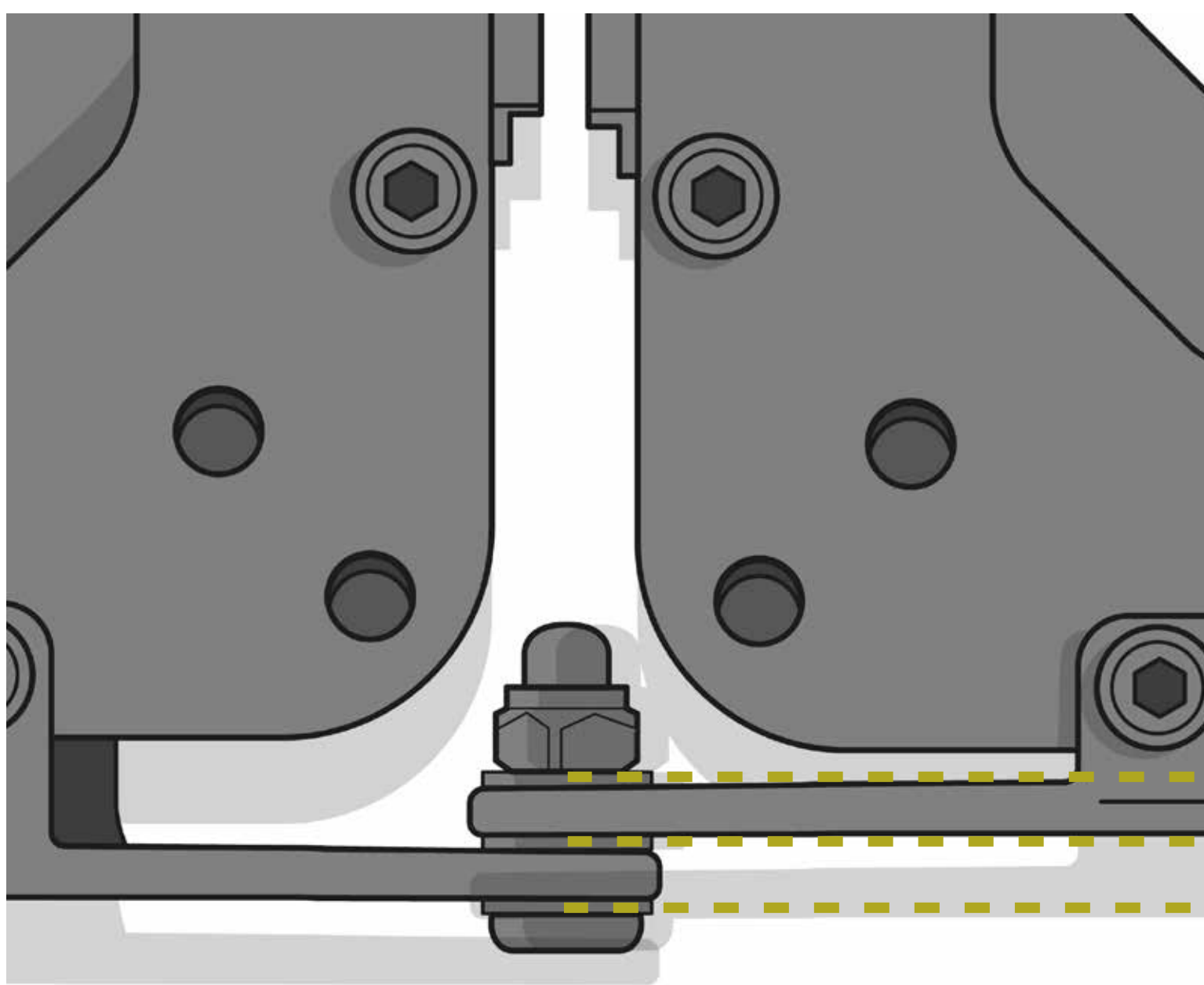
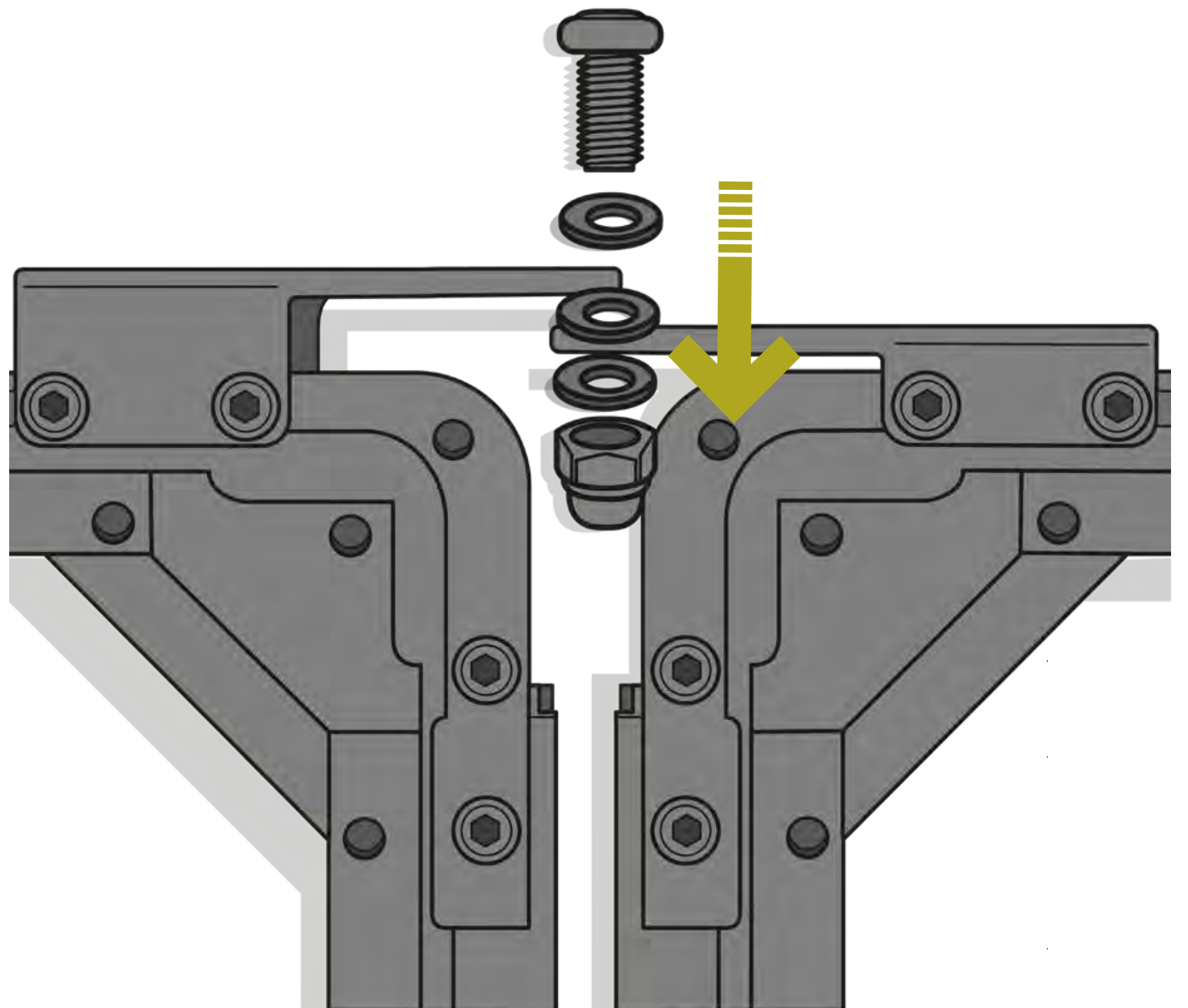

Washers

- Using the supplied m13 wrench and larger hex key, tighten.

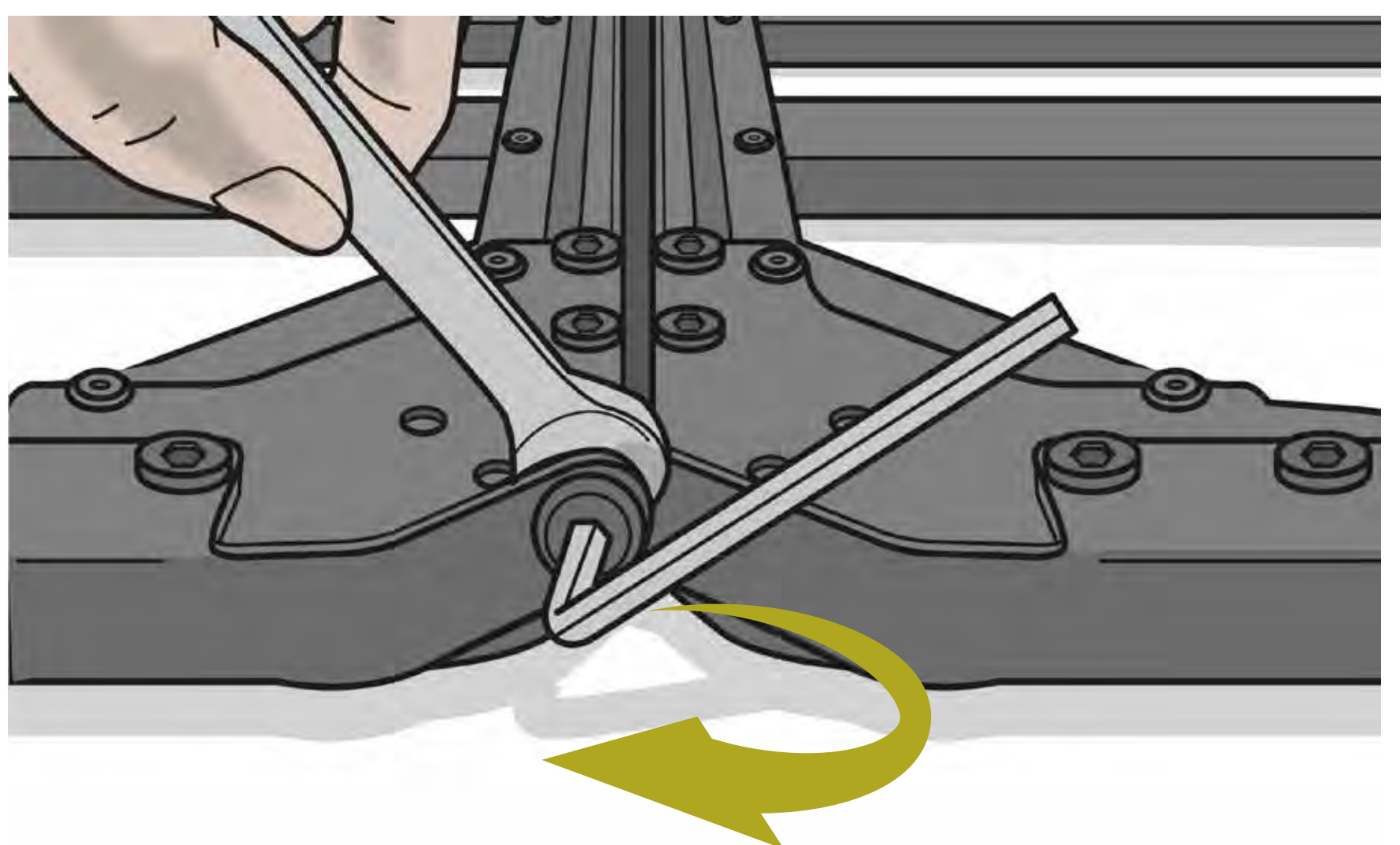



INSTALL LOCKS

SUMMARY Almost done! **Packet H** contains the locks, small slider nuts and flat head screws and small spring washers used to attach the 2 locks and 2 latches to the top and bottom halves of the platform.

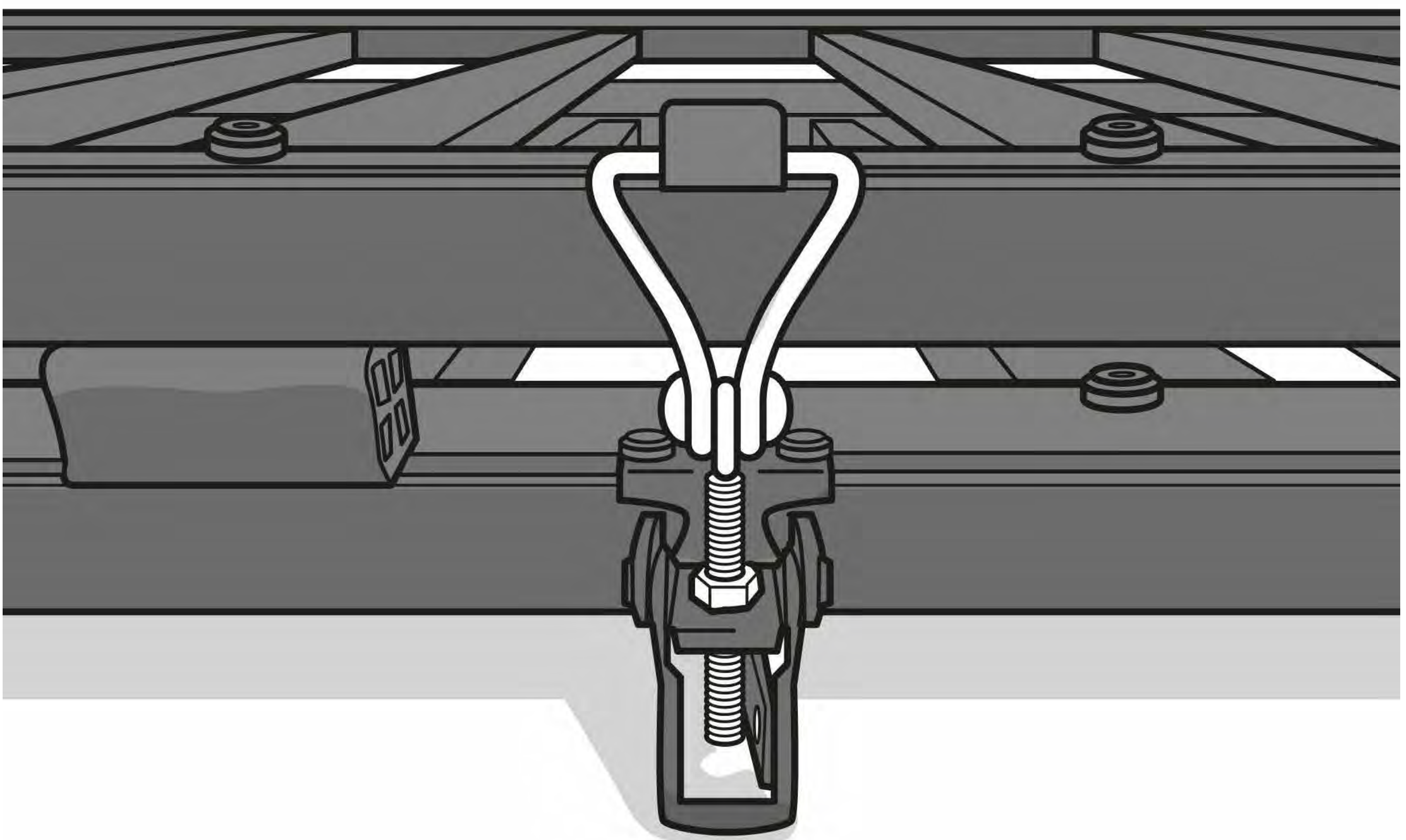
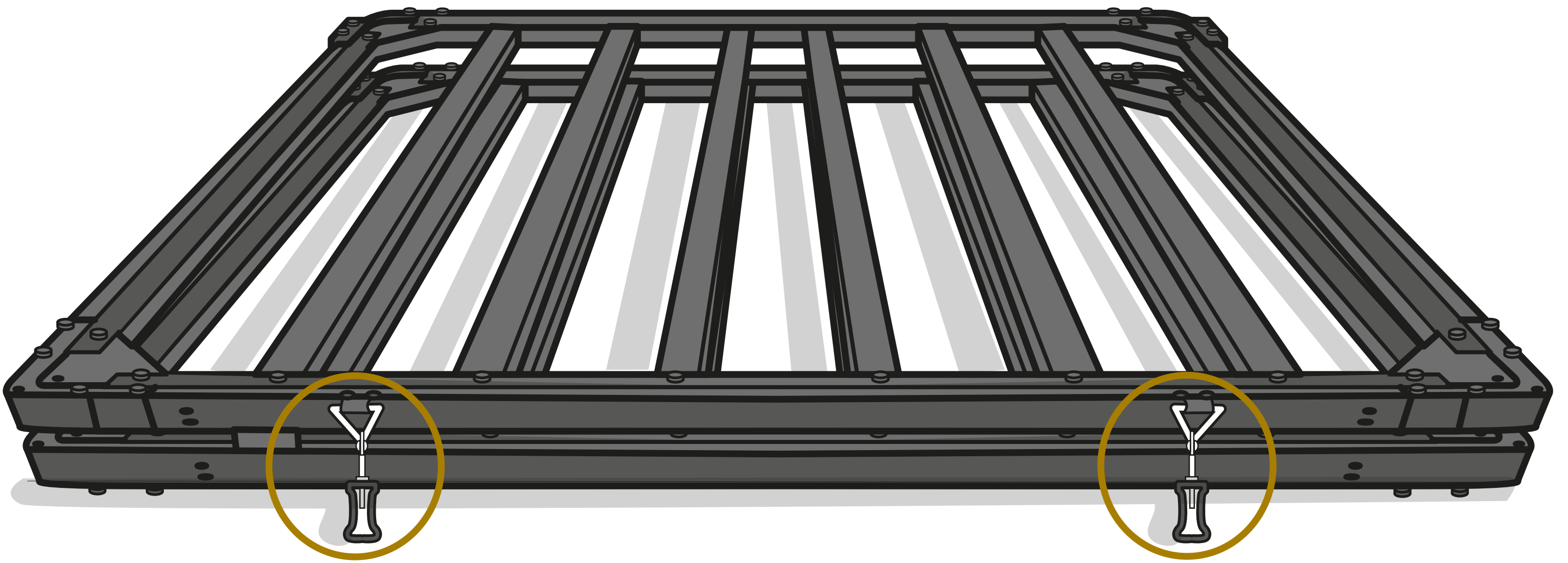



- In the same outer profile channel as the spacers, slide in slider nuts from **Packet H. 2** on each side. Note direction.

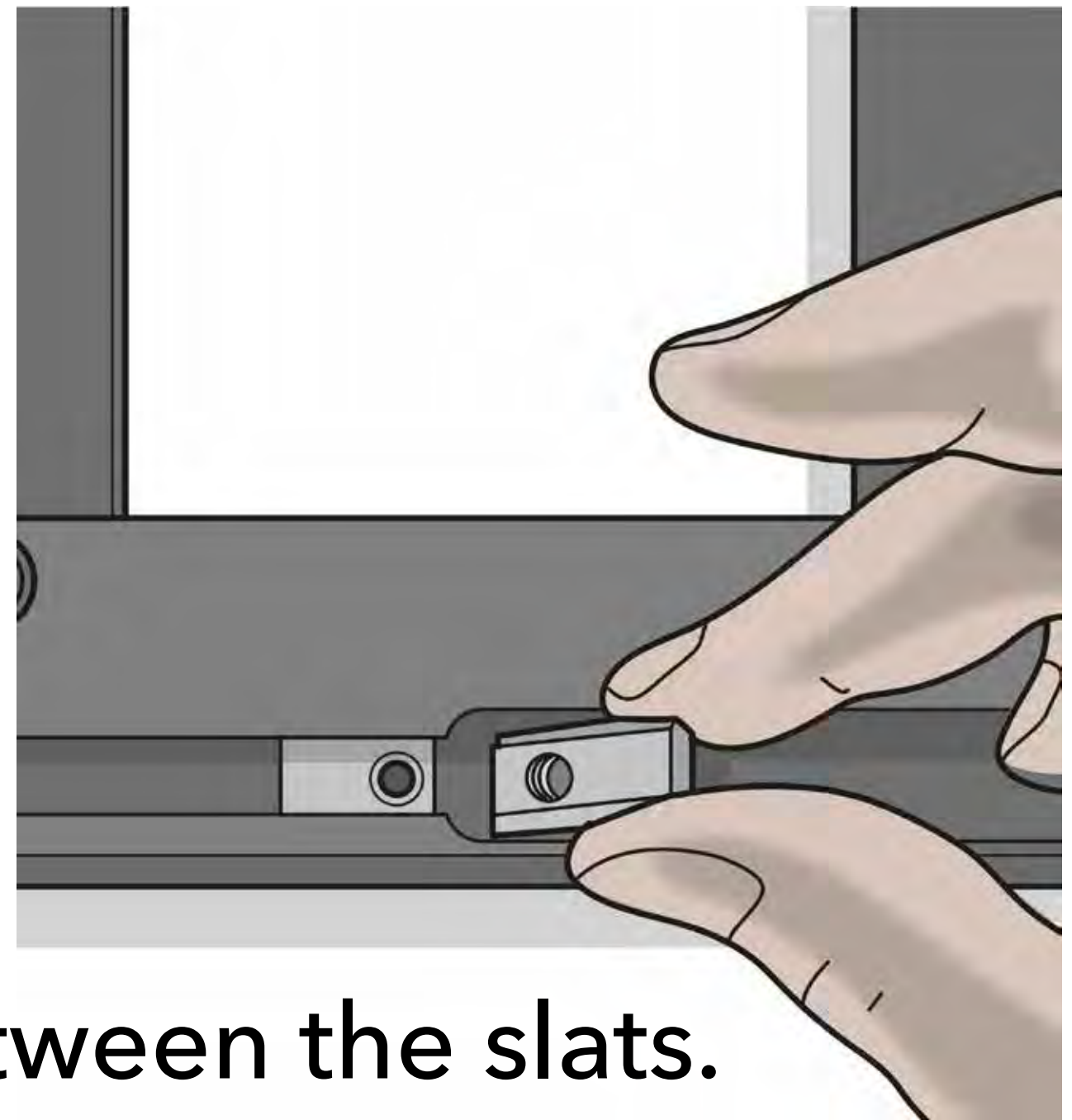

- Center the slider nuts between the slats.

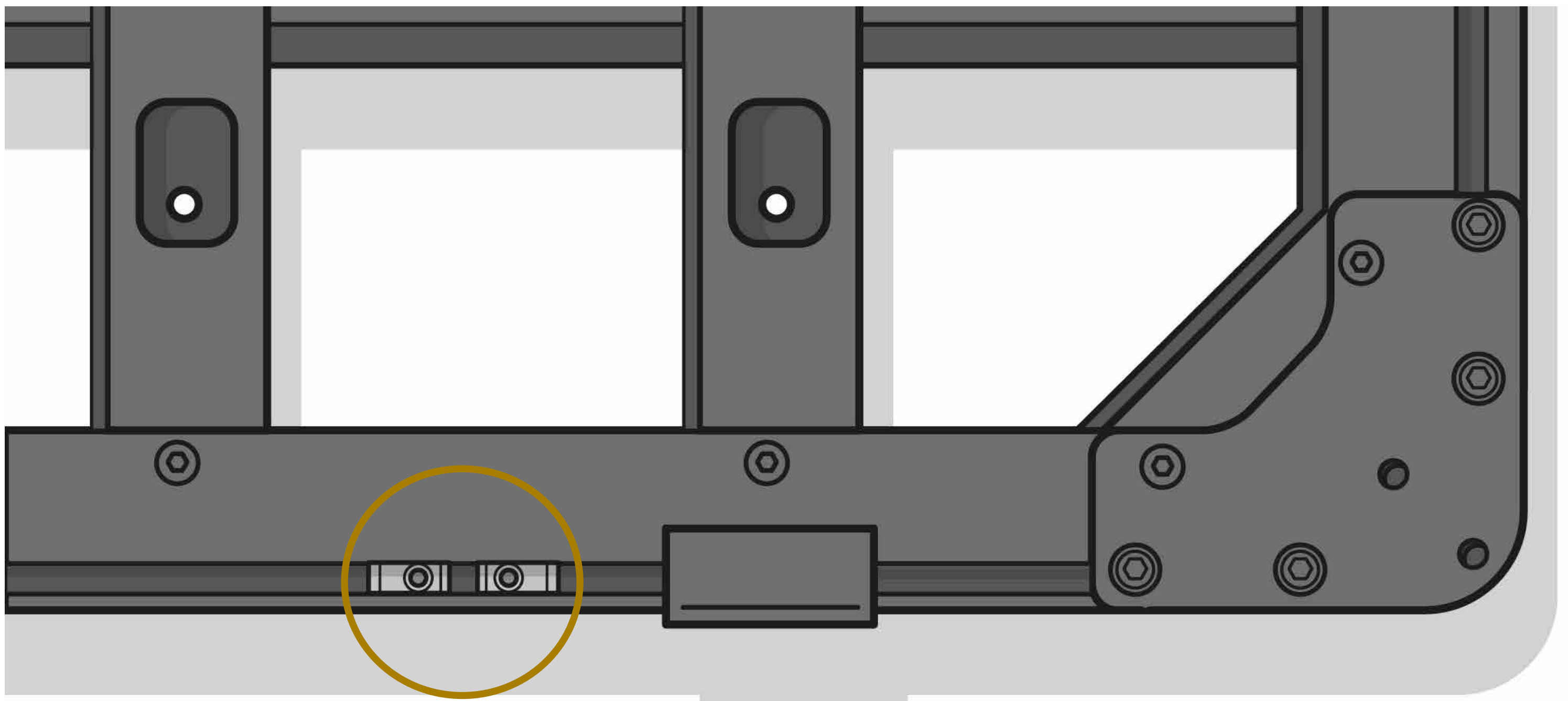

- Position lock latch and use 2 screws, 2 spring washers from **packet H** to fasten the top of the lock latch to the nut sliders using the included screwdriver.

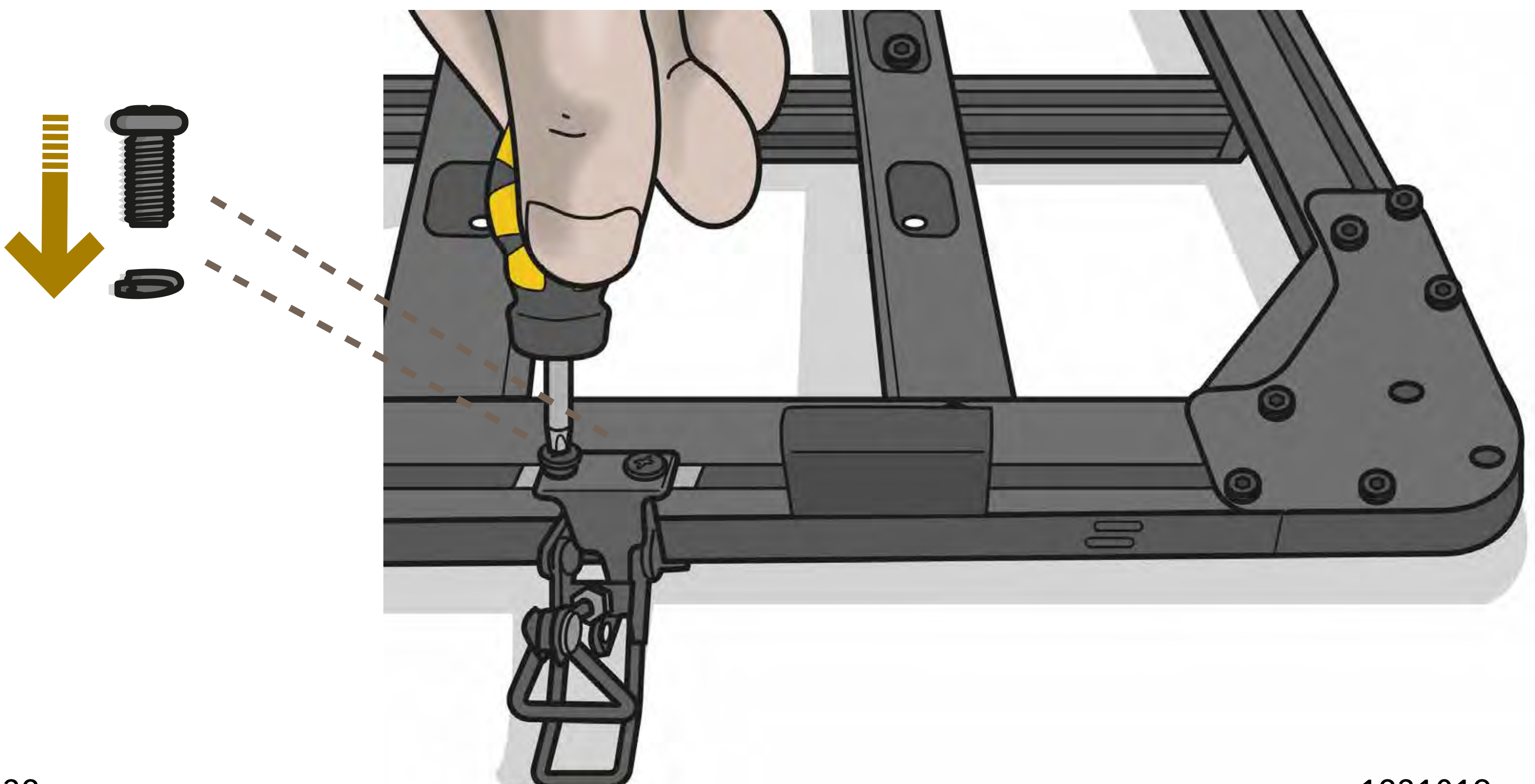



- Repeat this same step to attach the top of the 2nd lock latch near the other stopper.
- Turn the Rev Platform over and secure the bottom of each lock latch. Use 1 slider nut, scREW and washer.

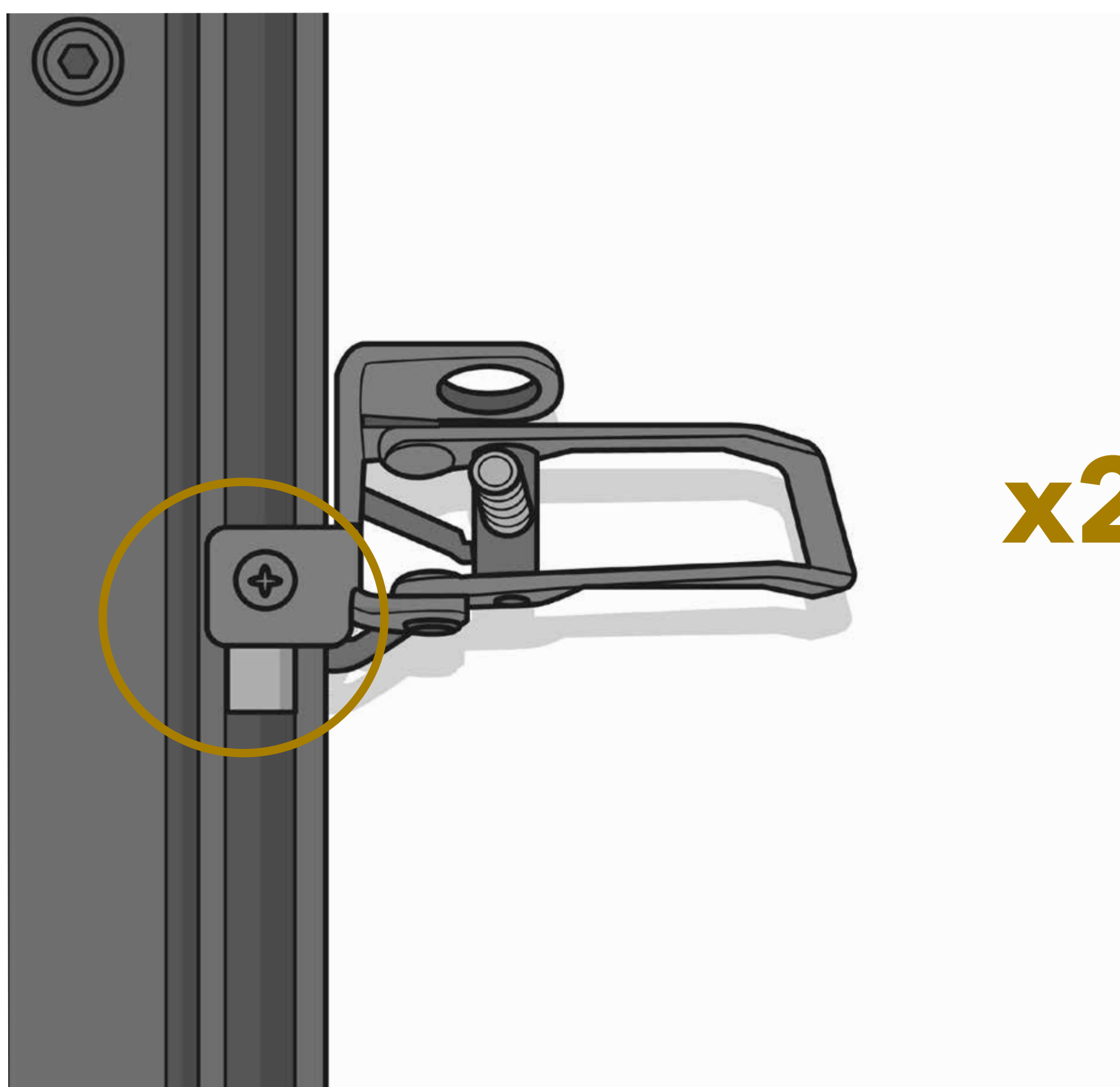

- Flip the platform back over. Now you're going to add the latch hooks to the other platform half. Yeah. This sucks. But you're almost done!

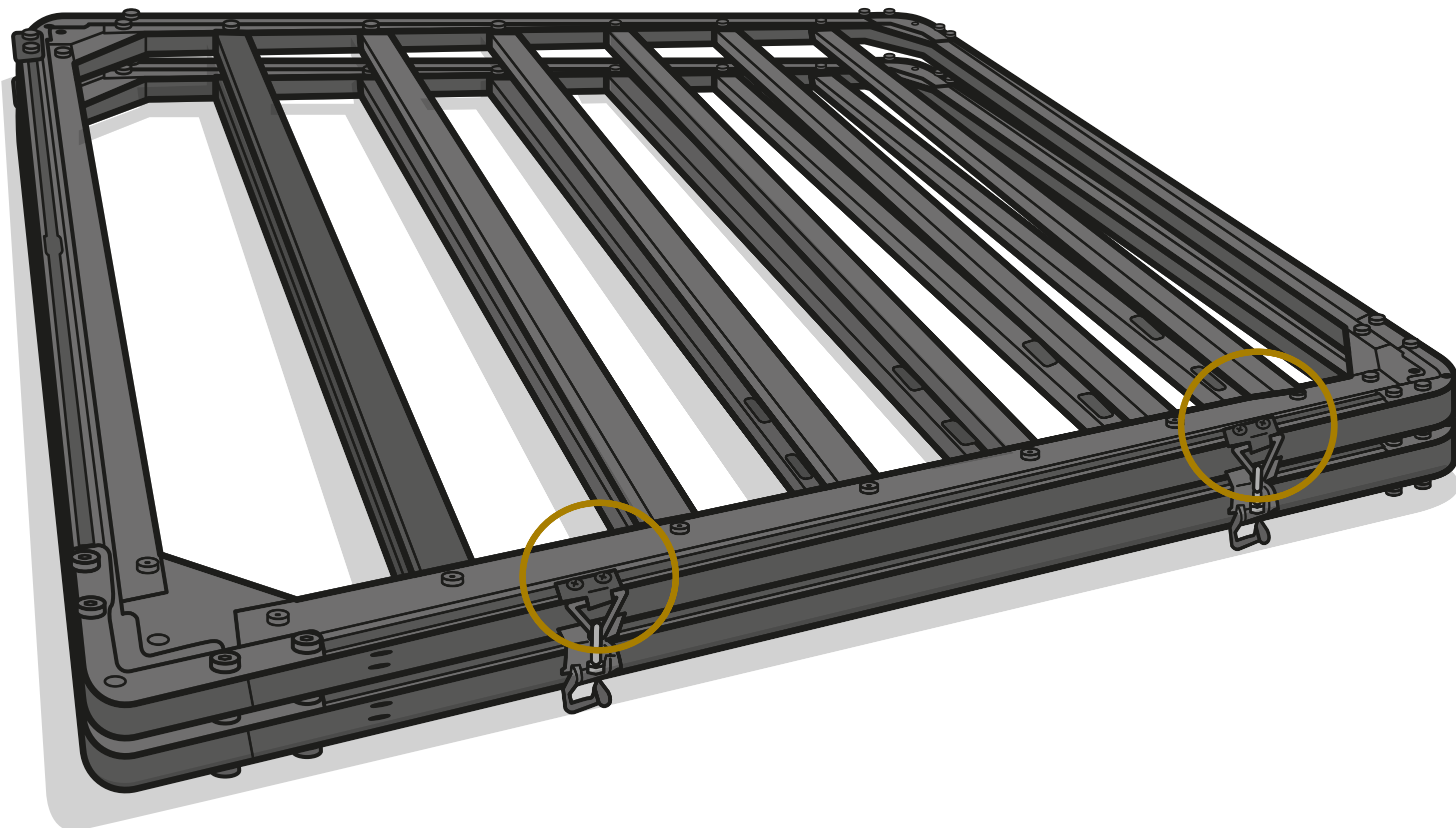



- Use the latch hooks and hardware from **packet H**.

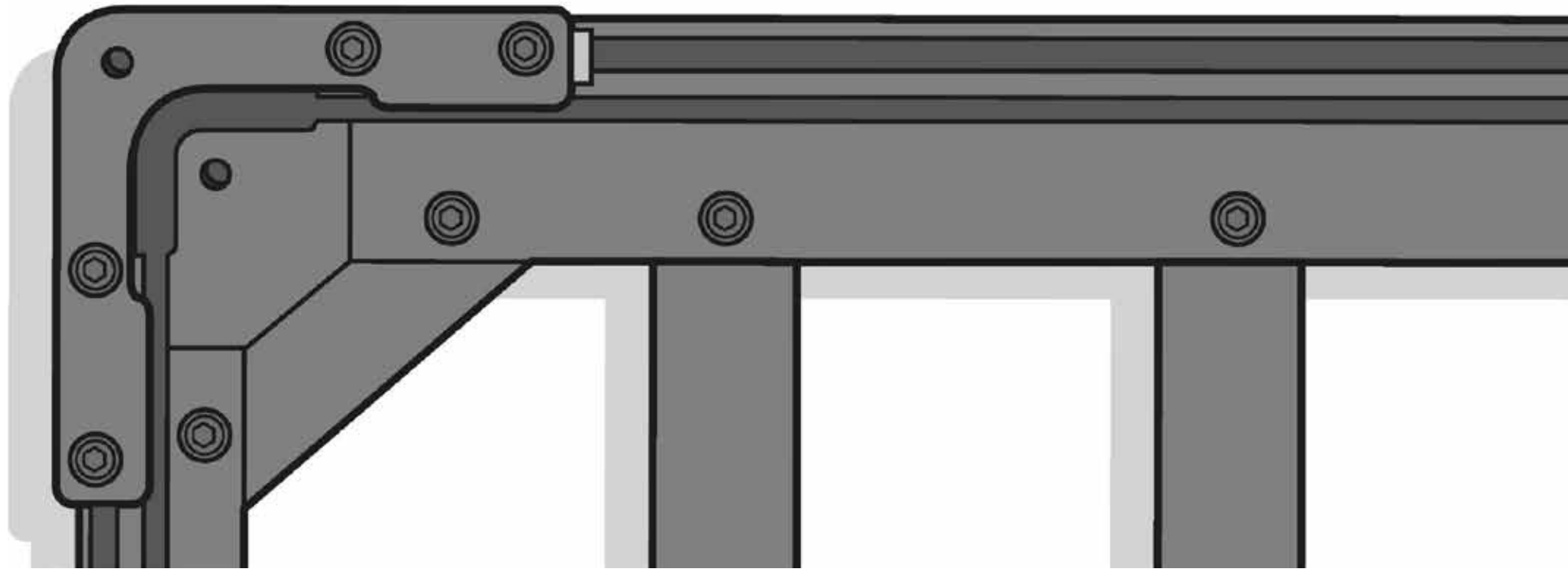
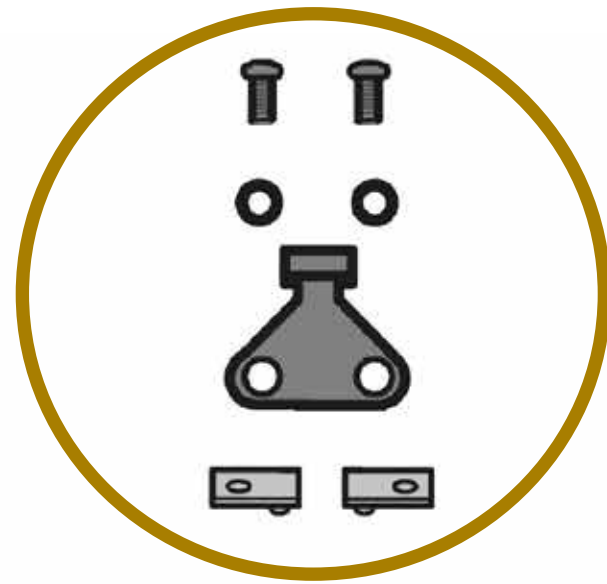

- Insert 2 slider nuts using the outer profile bottom channel center slot opening. Install latch hook lined up with bottom lock latch (between the 2 slats), hook facing up.

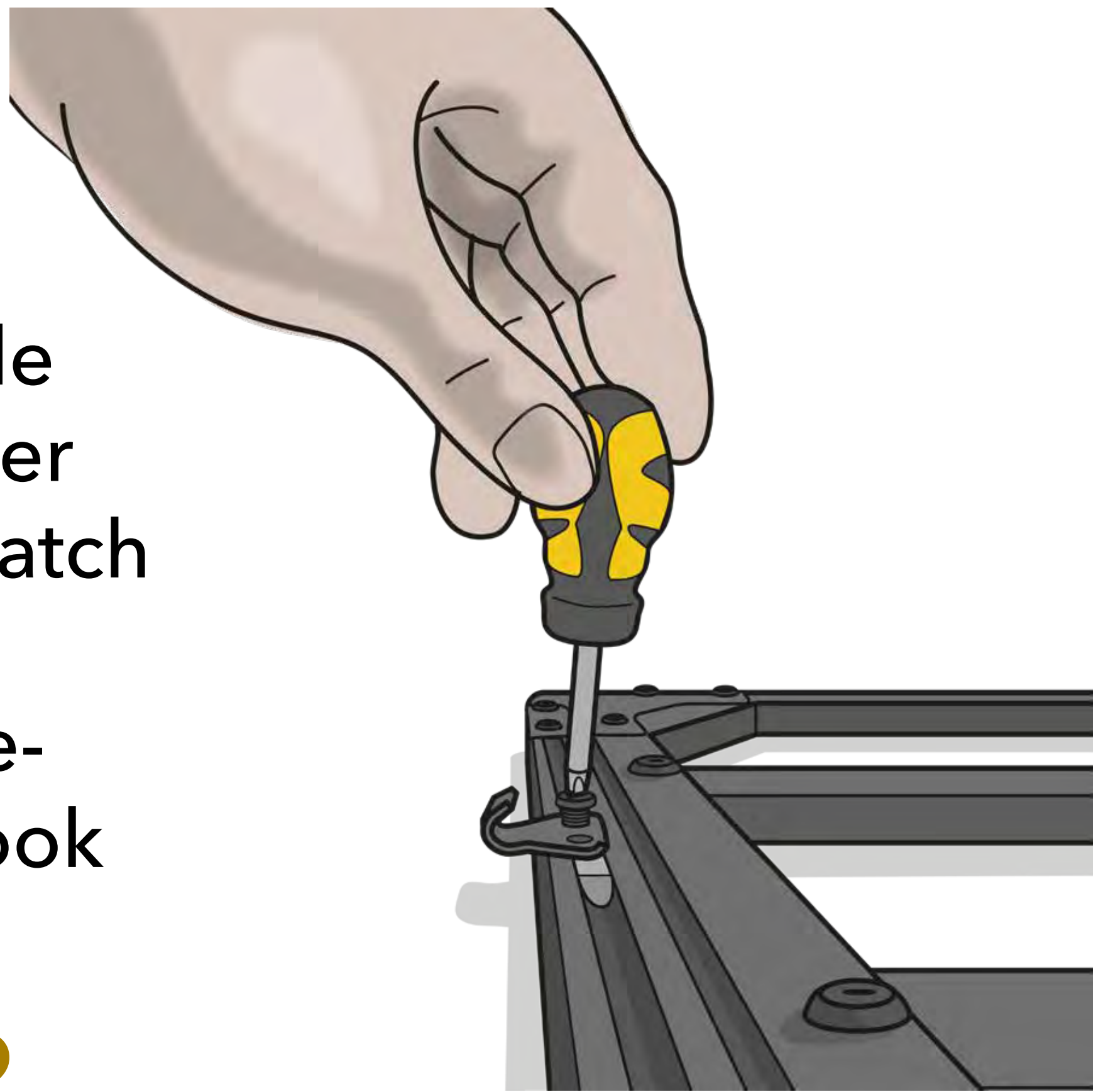

x2

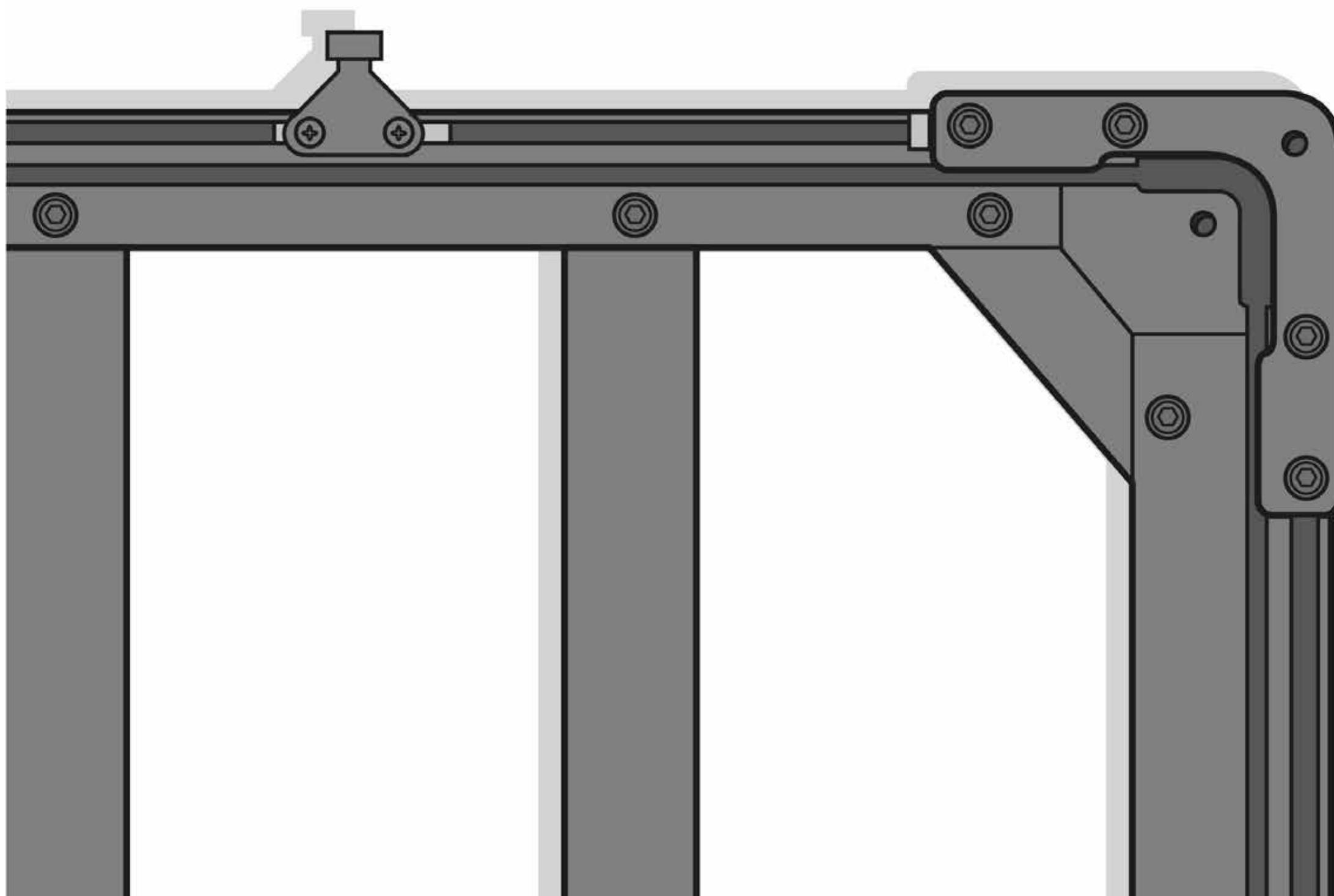



- Close and latch. Slide latch hooks into better position if necessary and re-tighten. Twist stem of latch lock to length. Use nut to lock stem length. Make sure there's tension enough to slightly squeeze the spacer. The latch shouldn't be too difficult to close, but there should be tension enough to keep the latch firmly locked.

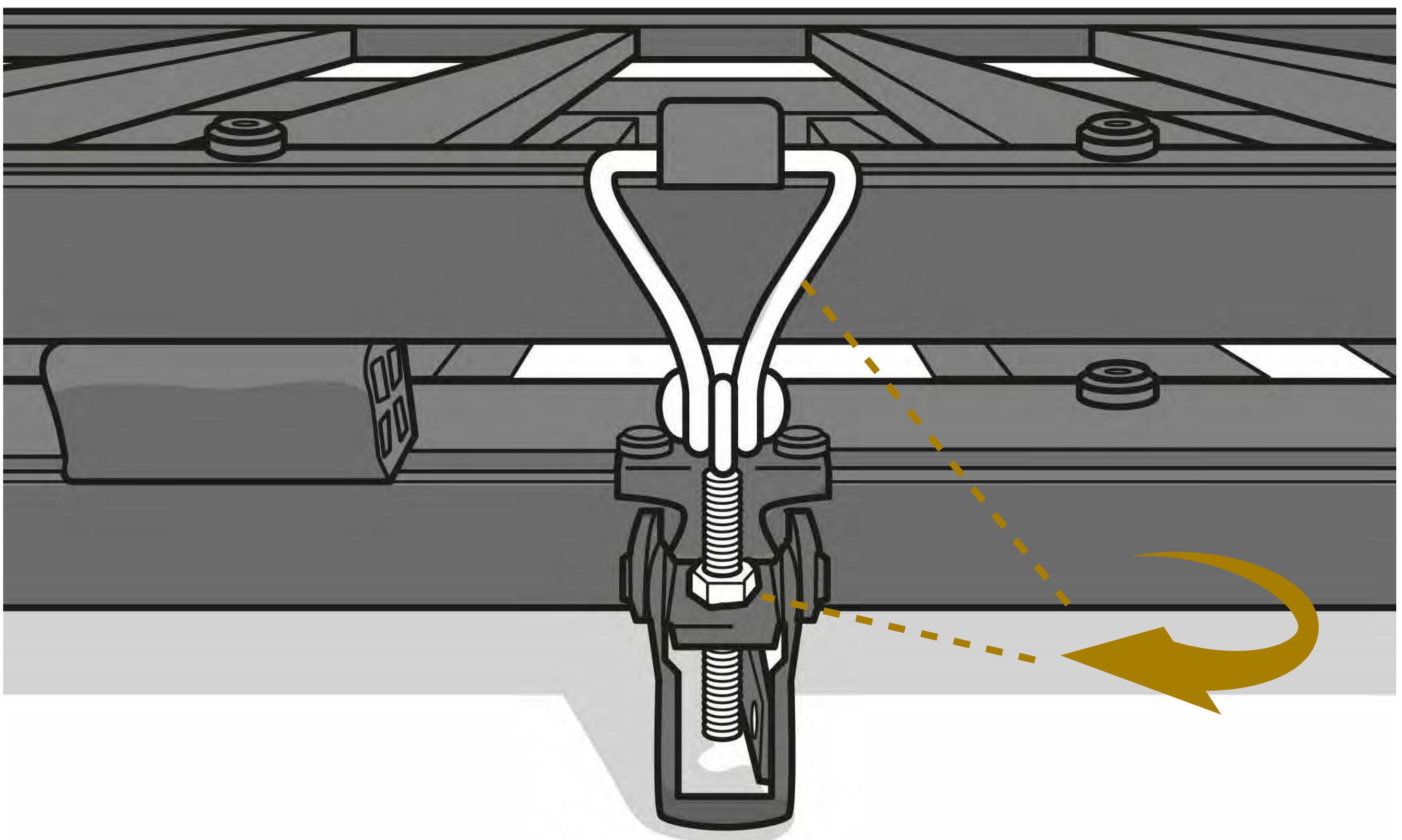

NEVER travel without first latching the Rev Platform closed! Always quadruple check that the Rev Platform is locked closed before moving the vehicle.



INSTALL LADDER HINGE PINS

SUMMARY With the platform opened, mount the quick-release ladder hinge pins (**packet I**) on the top platform half.

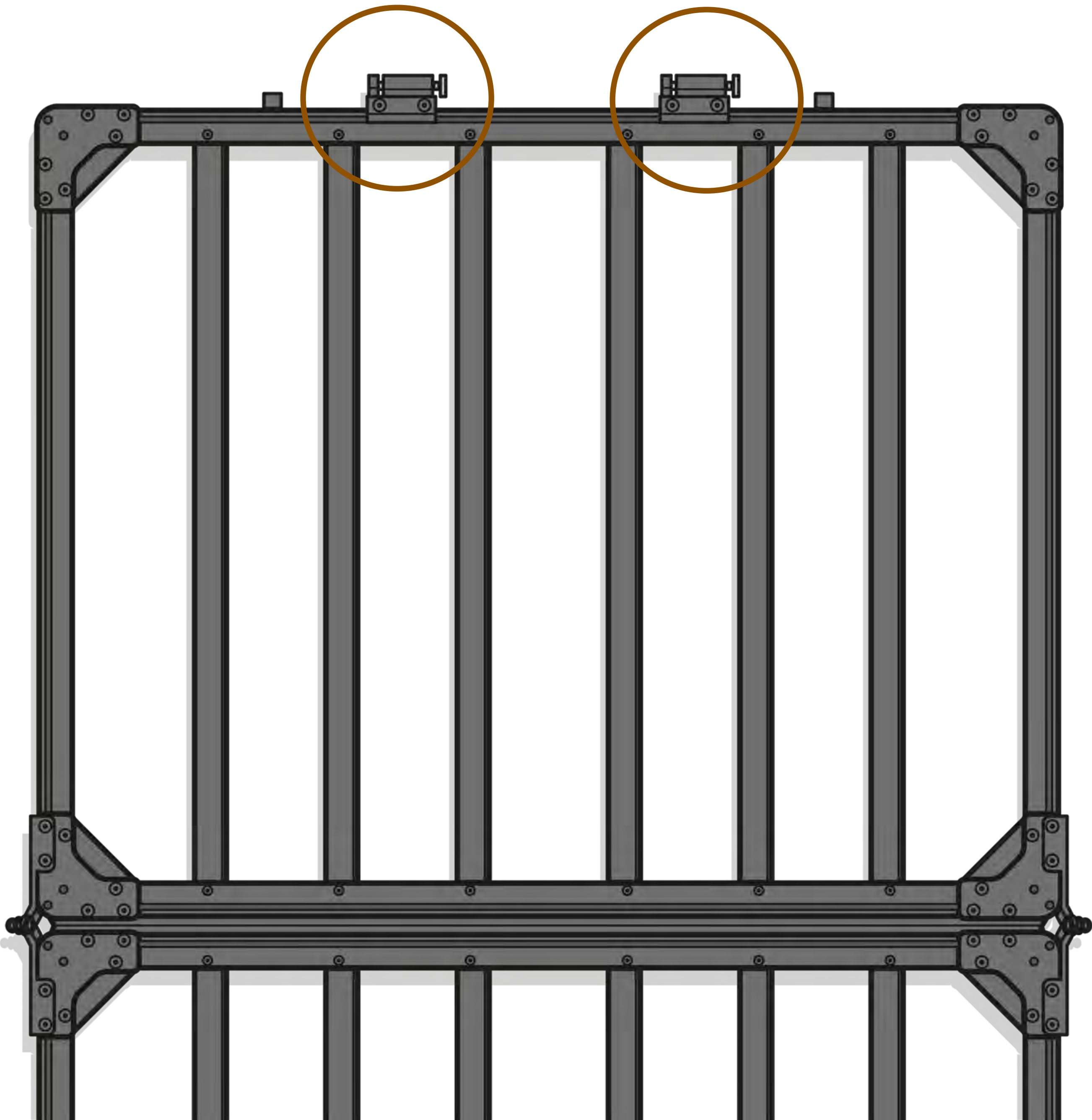

BTW - this is the last step. F-Yeah!

- Open the platform. The ladder hinge pins will be installed along the single channel on the top of the open platform on the end of the platform with the latch hooks (not on the end of the platform with the latch locks).



- You know the drill by now. Insert 2 slider nuts from **packet A**.

- Take the hinge pin ladder hardware (**packet I**) and bolts (**packet D**) and spring washers (**packet C**) and secure loosely. Only a few turns.

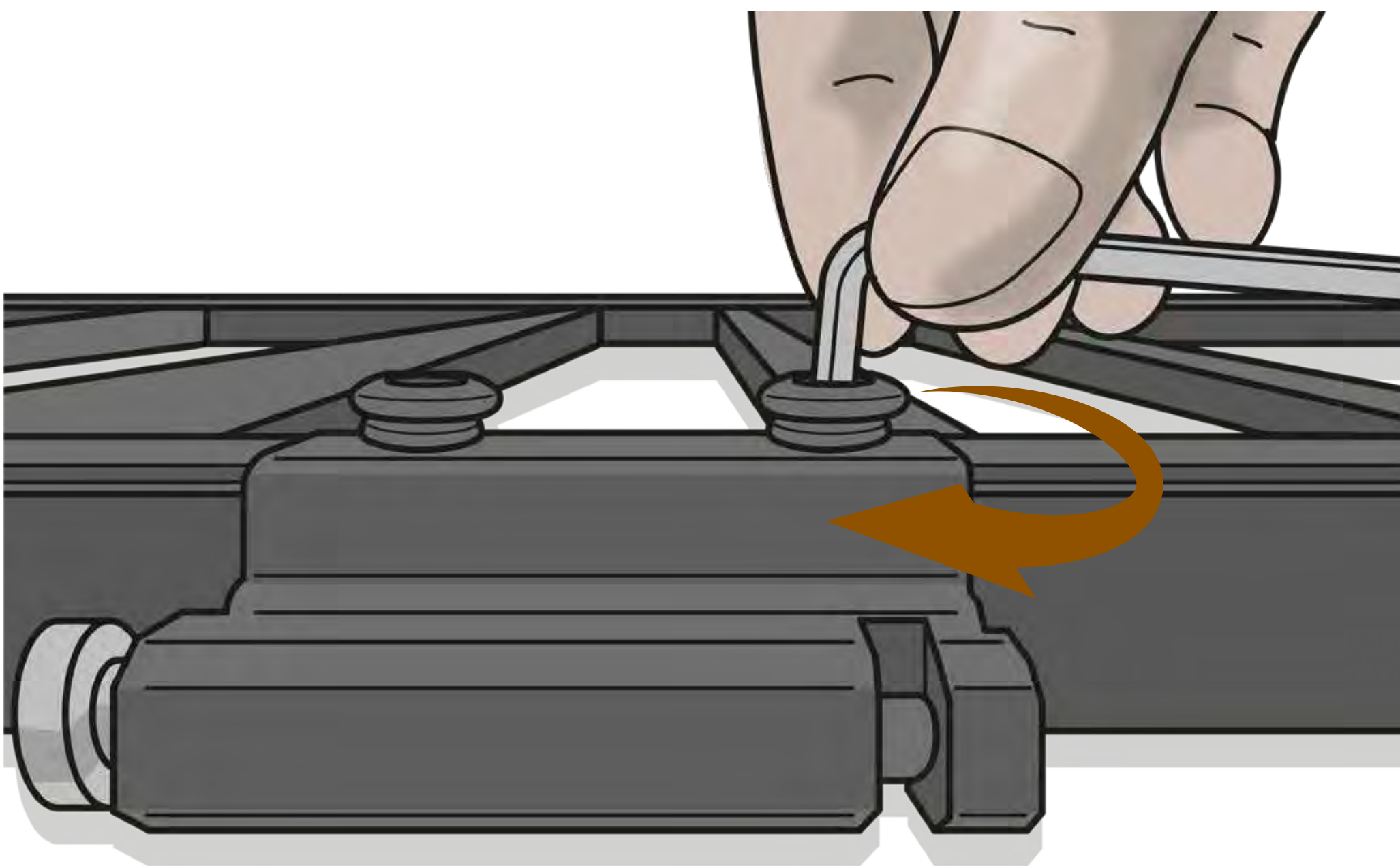
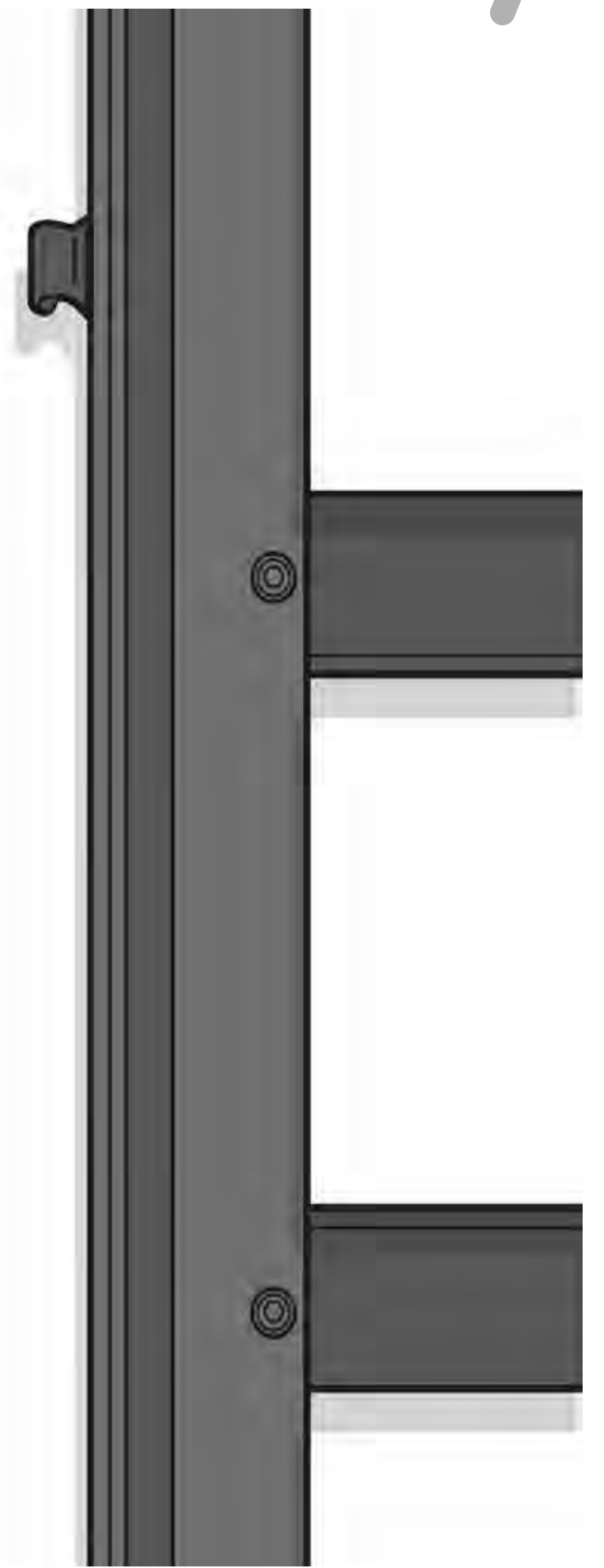
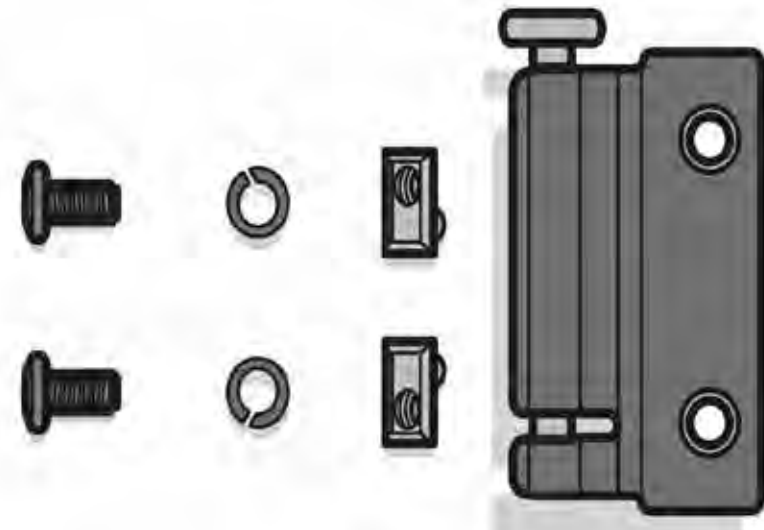

- Repeat for the 2nd ladder hinge pin.

- To find the exact placement of the ladder hinges, we will use the ladder as reference.

Take ladder and remove the ladder hinge plates from their bag, and lock them in to the ladder.

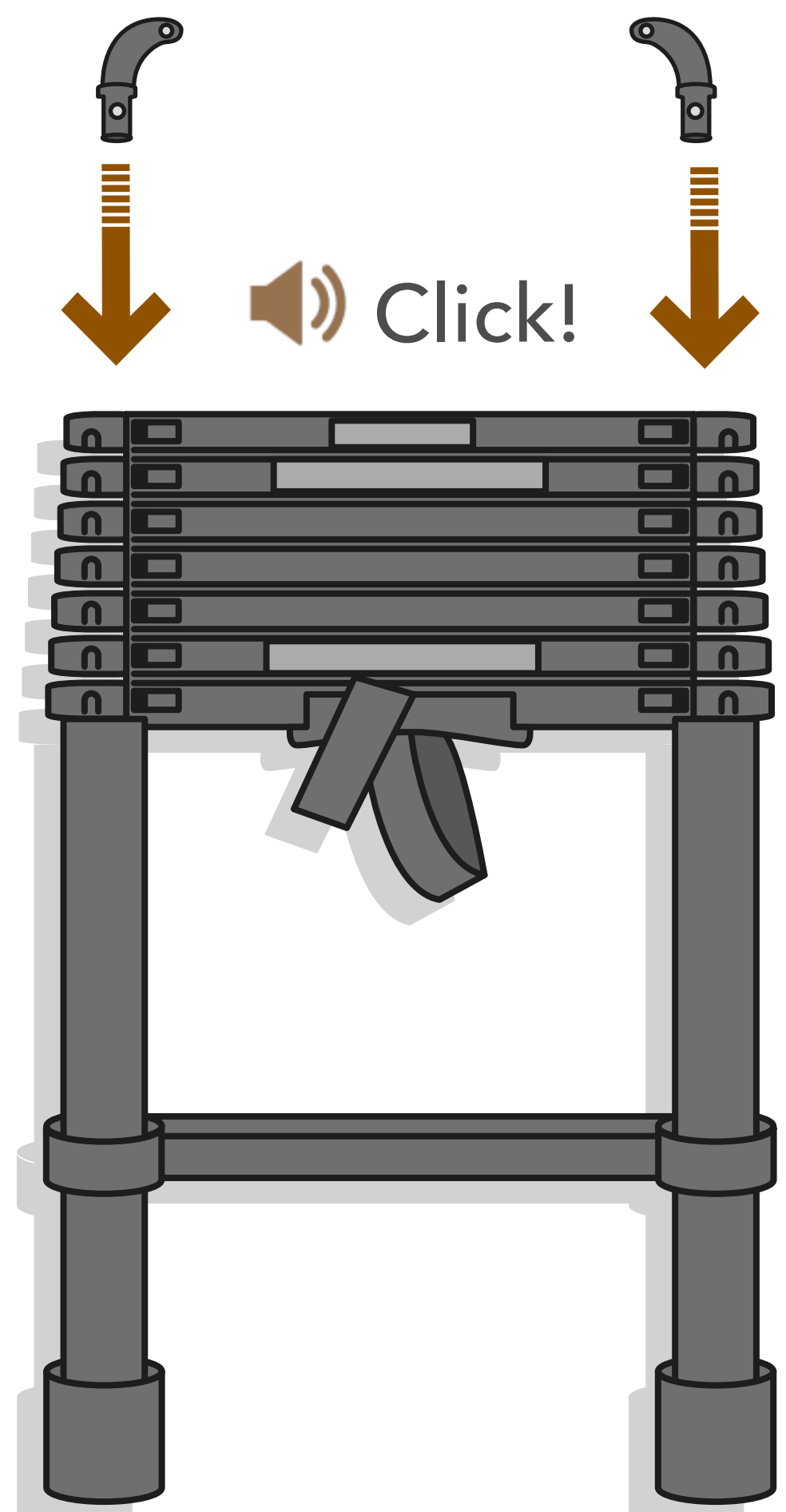

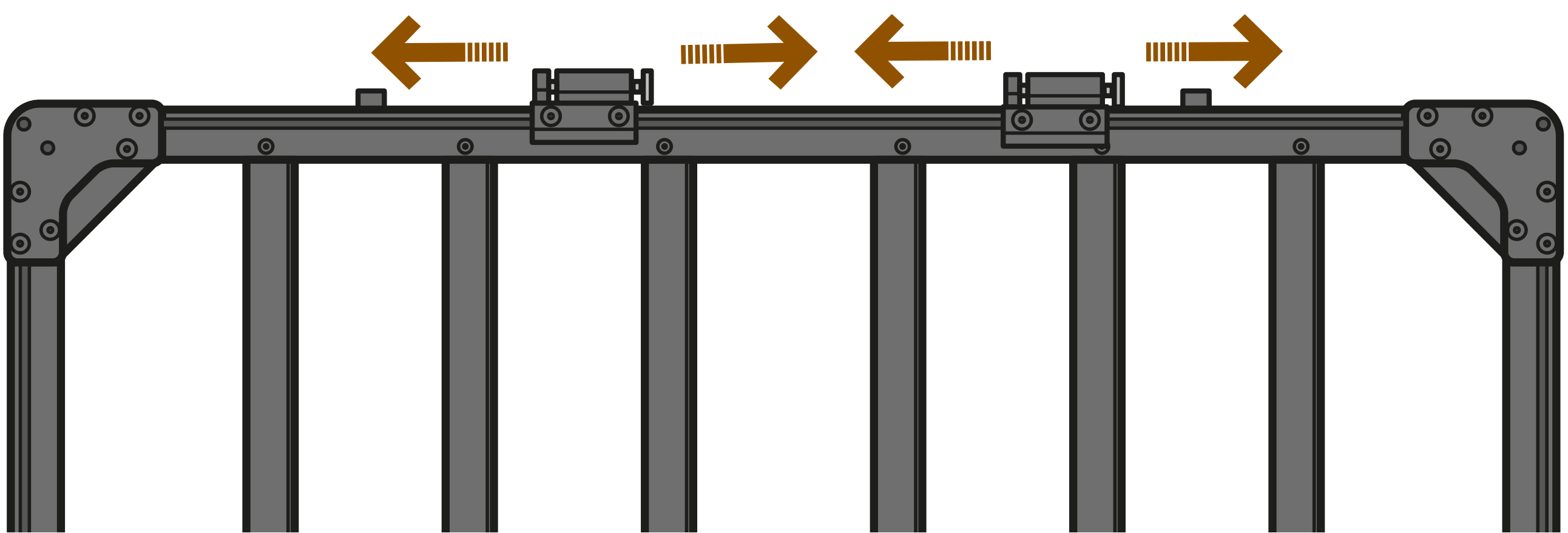
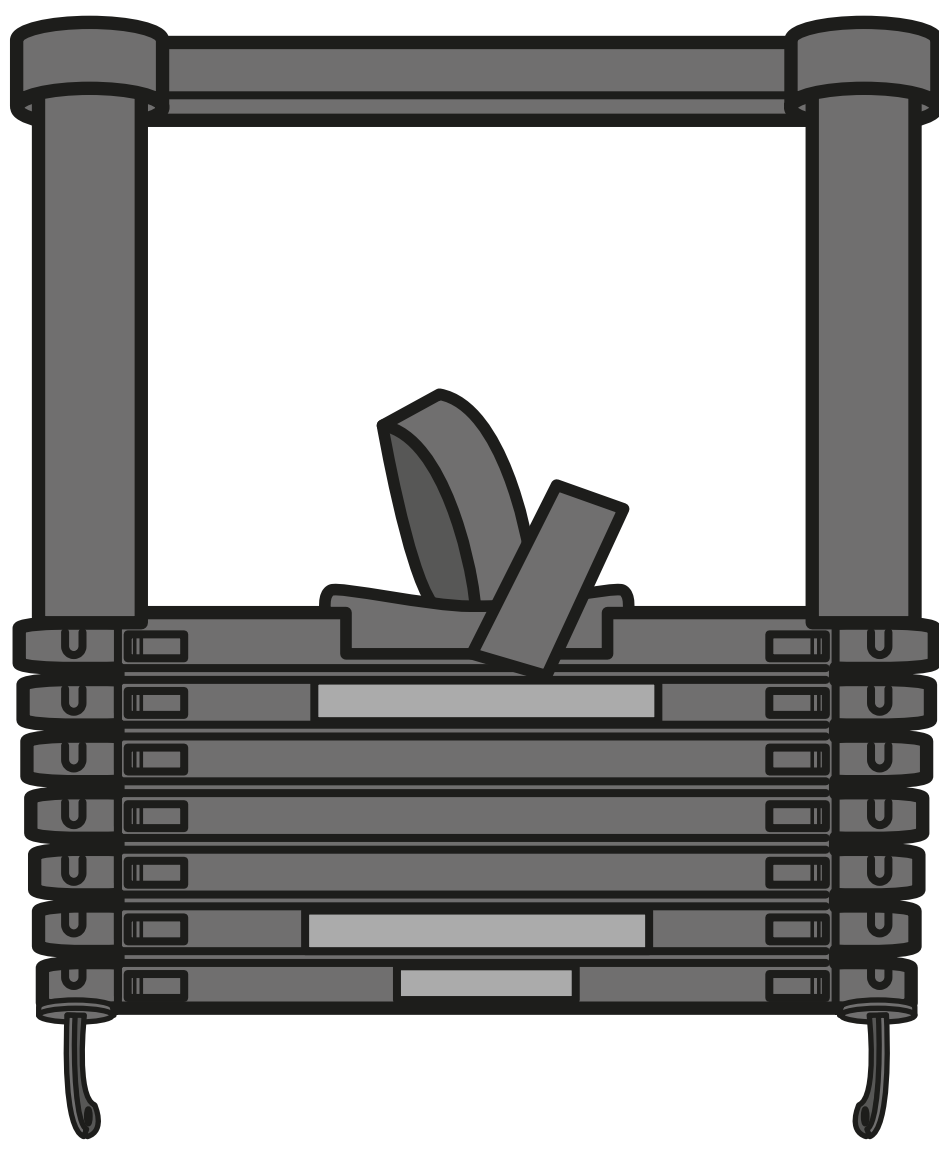

Center ladder along width of platform.

Slide hinge pins on platform to line up up with the hinge plates on the ladder.

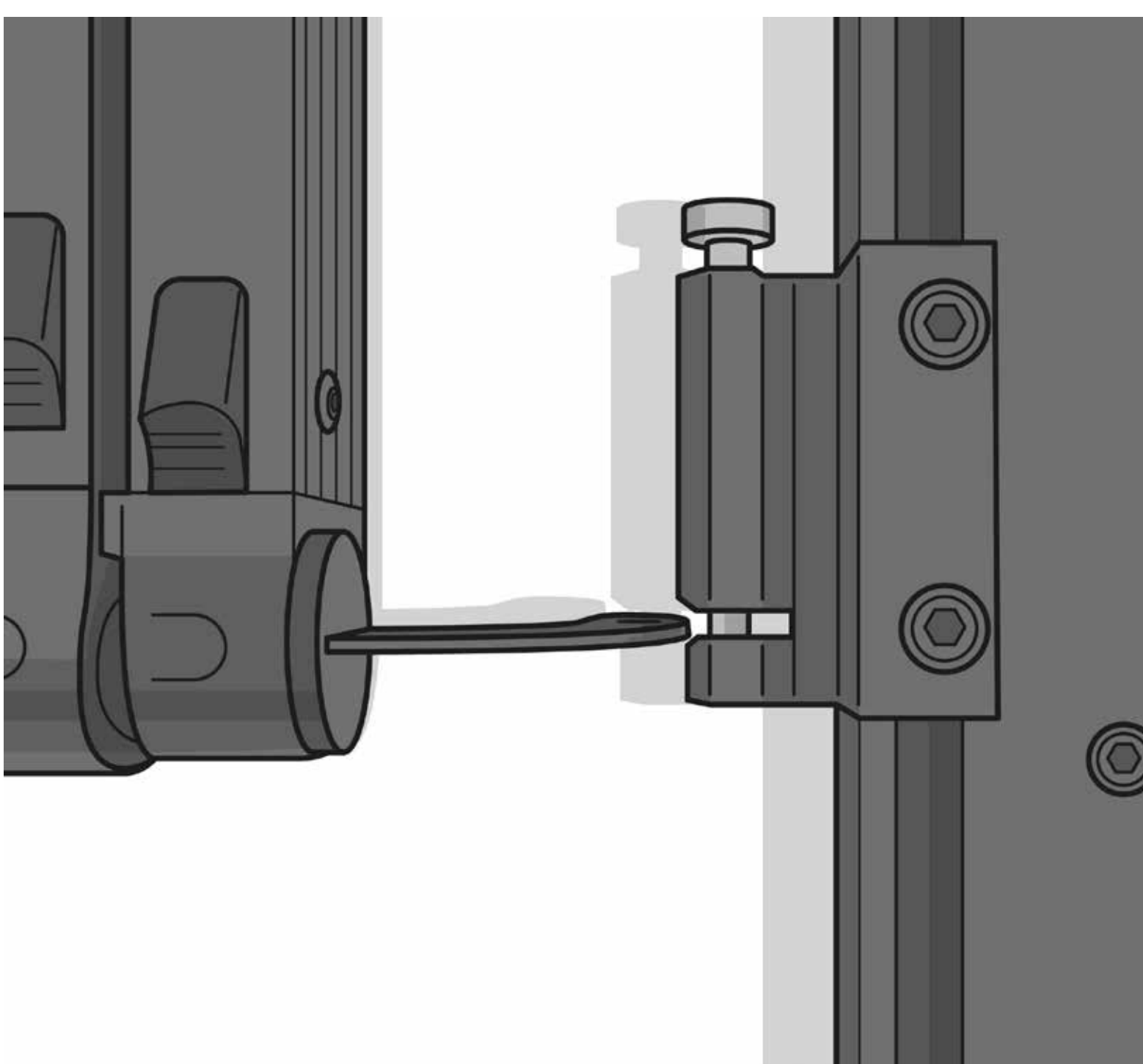

- With ladder centered and hinge pins lined up, tighten all 4 hinge pin bolts.

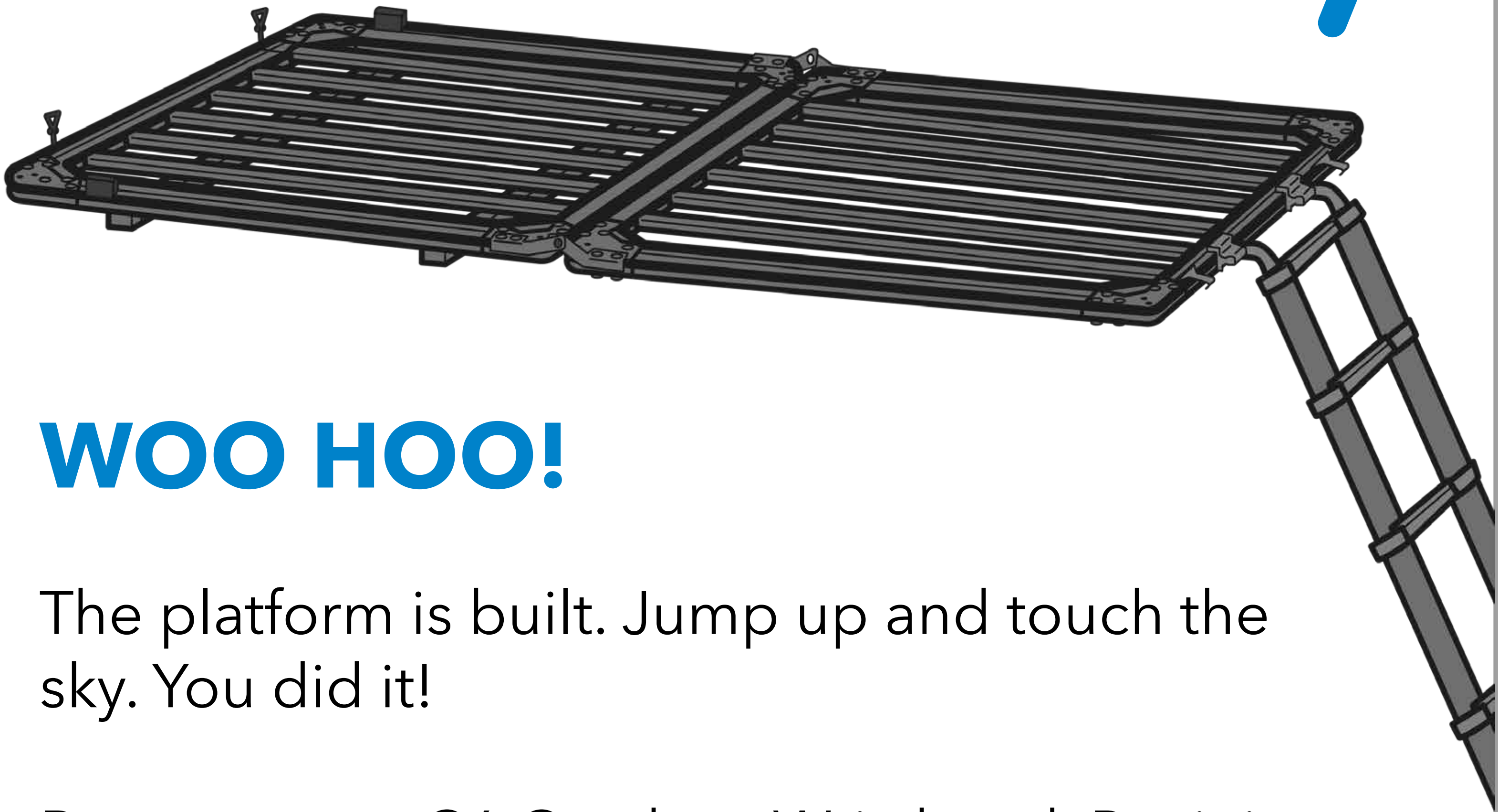

WOO HOO!

The platform is built. Jump up and touch the sky. You did it!

Remove your C6 Outdoor Wristband. Put it in a safe place. Let it serve as a reminder of your perseverance and smarts. This is an accomplishment that should not be forgotten.

To mount the Rev Platform X to your vehicle for camping with a Rev Tent, please see download these instructions :

REV ROOF TOP TENT INSTALL & USE INSTRUCTIONS

Also available to download at c6outdoor.com for smart phones, tablets or to print.

JOIN THE REVOLUTION

C6 outdoor



SHOP REV TENT ACCESSORIES

#RevTent

#BeFun

#C6outdoor

support.C6outdoor.com

Share /
Connect





WARNING

Refer to your specific vehicle manufacturer's recommendations for roof load rating. Refer to your specific cross bar or roof rack manufacturer's recommendations for load ratings. C6 Outdoor cannot be responsible for improper loading beyond the vehicle manufacturer and cross bar manufacturer's stated load capacity.

The Rev Roof Top Tent system weighs @87lbs / 40kg.

IT IS CRITICAL THAT ALL C6 OUTDOOR GEAR IS PROPERLY AND SECURELY ATTACHED TO YOUR VEHICLE. IMPROPER ATTACHMENT COULD RESULT IN AN AUTOMOBILE ACCIDENT AND COULD CAUSE SERIOUS BODILY INJURY OR DEATH TO YOU OR TO OTHERS. YOU ARE RESPONSIBLE FOR SECURING THE PLATFORM, TENT & ACCESSORIES TO YOUR CAR, CHECKING THE ATTACHMENTS PRIOR TO USE, AND PERIODICALLY INSPECTING THE PRODUCTS FOR ADJUSTMENT, WEAR, AND DAMAGE. IT IS REQUIRED THAT YOU READ AND UNDERSTAND ALL OF THE INSTRUCTIONS AND CAUTIONS SUPPLIED PRIOR TO INSTALLATION OR USE. IF YOU DO NOT UNDERSTAND ALL OF THE INSTRUCTIONS AND CAUTIONS, OR IF YOU HAVE NO MECHANICAL EXPERIENCE AND ARE NOT THOROUGHLY COMFORTABLE WITH THE INSTALLATION PROCEDURES, YOU SHOULD HAVE THE PRODUCT INSTALLED BY A PROFESSIONAL INSTALLER SUCH AS A QUALIFIED GARAGE OR AUTO BODY SHOP.



MORE WARNINGS

EN When transporting the Rev Platform X with or without the Rev Tent, you **MUST** lock the platform closed. Do not transport Rev Ladder directly attached to Rev Platform.

To extend the usable life of your Rev Tent and Rev Platform, we recommend storing the tent and platform out of the sun and weather elements when not in use.

When securing the Rev Tent and Rev Platform to a vehicle for transport or sleeping - check all hardware often. Failure to properly secure the Rev Tent and Platform to a vehicle could result in bodily harm and even death. Please review these instructions periodically. A safe camper is a happy camper!

ES Al transportar la Plataforma Rev X con o sin la Tienda Rev, **DEBE** cerrar la plataforma con llave. No transporte la escalera Rev Ladder directamente acoplada a la plataforma Rev Platform.

Para prolongar la vida útil de su Tienda Rev y Plataforma Rev, nosotros recomendamos guardar la tienda y la plataforma al abrigo del sol y de la intemperie elementos cuando no se utilicen.

Cuando fije la tienda Rev Tent y la plataforma Rev Platform a un vehículo para su transporte o para dormir, compruebe a menudo todos los herrajes. Si no se fijan correctamente la Carpa Rev y la Plataforma a un vehículo, podrían producirse lesiones corporales e incluso muerte. Revise estas instrucciones periódicamente. ¡Un campista seguro es un campista feliz!

DE Beim Transport der REV-Plattform X mit oder ohne REV-Zelt **mÜSSEN** Sie die Plattform verriegeln. Transportieren Sie die REV-Leiter nicht direkt an der REV-Plattform.

Um die Nutzungsdauer Ihres REV-Zeltes und Ihrer REV-Plattform zu verlängern, haben wir empfohlen, das Zelt und die Plattform außerhalb der Sonne und des Wetters zu lagern elemente, wenn sie nicht verwendet werden.

Wenn Sie das REV-Zelt und die REV-Plattform für den Transport oder zum Schlafen an einem Fahrzeug befestigen, überprüfen Sie die gesamte Hardware häufig. Wenn das REV-Zelt und die REV-Plattform nicht ordnungsgemäß an einem Fahrzeug befestigt werden, kann dies zu Körperverletzungen und sogar tod. Bitte überprüfen Sie diese Anweisungen regelmäßig. Ein sicheres Wohnmobil ist ein glücklicher Camper!

FR Lors du transport de la plate-forme Rev X avec ou sans la tente Rev, vous **DEVEZ** verrouiller la plate-forme en position fermée. Ne pas transporter l'échelle Rev directement attachée à la plate-forme Rev.

Pour prolonger la durée de vie de votre Rev Tent et Rev Platform, nous avons recommandé de stocker la tente et la plate-forme à l'abri du soleil et des intempéries lorsqu'ils ne sont pas utilisés.

Lorsque vous fixez la tente Rev et la plate-forme Rev à un véhicule pour le transport ou pour dormir, vérifiez souvent tout le matériel. Le fait de ne pas fixer correctement la tente et la plate-forme Rev Tent à un véhicule peut entraîner des blessures corporelles, voire des dommages matériels. la mort. Veuillez consulter régulièrement ces instructions. Un campeur en sécurité est un campeur heureux !



NL Als je het Rev Platform X vervoert met of zonder de Rev Tent, MOET je het platform sluiten. Vervoer de Rev Ladder niet rechtstreeks bevestigd aan het Rev Platform.

Om de levensduur van uw Rev Tent en Rev Platform te verlengen, raden wij u aan de tent en het platform uit de zon en de weerselementen te bewaren als u ze niet gebruikt.

Wanneer je de Rev Tent en het Rev Platform aan een voertuig bevestigt voor transport of om te slapen - controleer dan vaak alle hardware. Het niet goed bevestigen van de Rev Tent en Platform aan een voertuig kan leiden tot lichamelijk letsel en zelfs de dood. Lees deze instructies regelmatig door. Een veilige kampeerder is een tevreden kampeerder!

PT Ao transportar a Rev Platform X com ou sem a Rev Tent, você DEVE bloquear a plataforma fechada. Não transporte Rev Ladder diretamente ligado à Rev Platform.

Para prolongar a vida útil da sua Tenda Rev e da Plataforma Rev, recomendamos que guarde a tenda e a plataforma fora do sol e dos elementos meteorológicos quando não estiver a ser utilizada.

Ao fixar a Tenda Rev e a Plataforma Rev a um veículo para transporte ou dormir - verifique todo o hardware com frequência. A falha em prender adequadamente a Tenda Rev e a Plataforma a um veículo pode resultar em lesões corporais e até morte. Por favor, revise estas instruções periodicamente. Um campista seguro é um campista feliz!

JA Rev Platform XをRev Tentの有無に関わらず運搬する際は、必ずプラットフォームを閉じてロックしてください。RevラダーをRevプラットフォームに直接取り付けて運搬しないでください。

レブ・テントとレブ・プラットフォームの使用寿命を延ばすため、使用しないときはテントとプラットフォームを日光や天候の影響を受けない場所に保管することをお勧めします。

レブ・テントとレブ・プラットフォームを輸送や就寝のために車両に固定する際は、すべての金具をよく確認してください。Rev TentとPlatformを適切に車両に固定しないと、身体的危害や死に至る可能性があります。これらの指示を定期的を確認してください。安全なキャンピングカーとは 幸せなキャンピングカーだ!

IT Quando si trasporta la Rev Platform X con o senza la tenda Rev, si DEVE bloccare la piattaforma chiusa. Non trasportare la scala Rev direttamente attaccata alla piattaforma Rev.

Per prolungare la durata della tenda Rev e della piattaforma Rev, si consiglia di riporre la tenda e la piattaforma al riparo dal sole e dagli agenti atmosferici quando non vengono utilizzate.

Quando si fissano la tenda Rev e la piattaforma Rev a un veicolo per il trasporto o il riposo, controllare spesso tutta la ferramenta. Il mancato fissaggio della tenda e della piattaforma Rev a un veicolo può causare lesioni fisiche o addirittura la morte. Si prega di rivedere periodicamente queste istruzioni. Un campeggiatore sicuro è un campeggiatore felice!

DA Når du transporterer Rev Platform X med eller uden Rev Telt, SKAL du låse platformen lukket. Transporter ikke Rev Ladder direkte fastgjort til Rev Platform.

For at forlænge levetiden af dit Rev Telt og Rev Platform anbefaler vi at opbevare teltet og platformen væk fra solen og vejret, når de ikke er i brug.

Når du fastgør Rev-teltet og Rev-platformen til et køretøj til transport eller til at sove - tjek alt hardware ofte. Manglende fastgørelse af Rev-teltet og platformen til et køretøj kan resultere i legemsbeskadigelse og endda død. Gennemgå venligst disse instruktioner med jævne mellemrum. En sikker camper er en glad campist!



IS Þegar Rev Platform X er flutt með eða án Rev tjaldsins, VERÐUR þú að læsa pallinum lokuðum. Ekki flytja Rev Ladder beint tengdum Rev pallinum.

Til að lengja endingartíma Rev tjaldsins og Rev pallsins mælum við með að tjaldið og pallurinn geymist ekki fyrir sól og veðri þegar það er ekki í notkun.

Þegar Rev tjaldið og Rev pallurinn er festur við ökutæki til flutnings eða svefns - athugaðu allan vélbúnað oft. Ef ekki er rétt að festa Rev tjaldið og pallinn við ökutæki gæti það leitt til líkamstjóns og jafnvel dauða. Vinsamlegast skoðaðu þessar leiðbeiningar reglulega. Öruggur húsbíll er ánægður húsbíll!

NO Þegar Rev Platform X er flutt með eða án Rev tjaldsins, VERÐUR þú að læsa pallinum lokuðum. Ekki flytja Rev Ladder beint tengdum Rev pallinum.

Til að lengja endingartíma Rev tjaldsins og Rev pallsins mælum við með að tjaldið og pallurinn geymist ekki fyrir sól og veðri þegar það er ekki í notkun.

Þegar Rev tjaldið og Rev pallurinn er festur við ökutæki til flutnings eða svefns - athugaðu allan vélbúnað oft. Ef ekki er rétt að festa Rev tjaldið og pallinn við ökutæki gæti það leitt til líkamstjóns og jafnvel dauða. Vinsamlegast skoðaðu þessar leiðbeiningar reglulega. Öruggur húsbíll er ánægður húsbíll!

PL Podczas transportu platformy Rev X z namiotem Rev lub bez niego MUSISZ zamknąć platformę. Nie należy transportować drabiny Rev przymocowanej bezpośrednio do platformy Rev.

Aby przedłużyć żywotność namiotu Rev i platformy Rev, zalecamy przechowywanie namiotu i platformy z dala od słońca i czynników atmosferycznych, gdy nie są używane.

Mocując namiot Rev i platformę Rev do pojazdu w celu transportu lub spania, często sprawdzaj cały sprzęt. Nieprawidłowe przymocowanie namiotu i platformy Rev do pojazdu może spowodować obrażenia ciała, a nawet śmierć. Prosimy o okresowe przeglądanie tych instrukcji. Bezpieczny kamper to taki szczęśliwy kamper!

RO Când transportați platforma Rev X cu sau fără cortul Rev, TREBUIE să blocați platforma închisă. Nu transportați Rev Ladder atașat direct la Rev Platform.

Pentru a prelungi durata de viață utilă a cortului Rev și a platformei Rev, vă recomandăm să depozitați cortul și platforma departe de soare și de elementele meteorologice atunci când nu sunt utilizate.

Când fixați cortul Rev și platforma Rev la un vehicul pentru transport sau dormit - verificați frecvent toate componentele hardware. Neasigurarea corespunzătoare a cortului și platformei de turație la un vehicul ar putea duce la vătămări corporale și chiar la moarte. Vă rugăm să consultați periodic aceste instrucțiuni. Un camper sigur este Un camper fericit!

SV När du transporterar Rev Platform X med eller utan Rev-tältet MÅSTE du låsa plattformen stängd. Transportera inte Rev Ladder direkt ansluten till Rev Platform.

För att förlänga livslängden på ditt Rev Tent och Rev Platform rekommenderar vi att du förvarar tältet och plattformen borta från sol och väderlek när de inte används.

När du fäster Rev-tältet och Rev-plattformen vid ett fordon för transport eller sovande - kontrollera all hårdvara ofta. Om Rev-tältet och plattformen inte säkras ordentligt vid ett fordon kan det leda till kroppsskada och till och med dödsfall. Läs igenom dessa instruktioner med jämna mellanrum. En säker husbil är en glad husbil!



KO Rev Tent를 사용하거나 사용하지 않고 Rev Platform X를 운송할 때 플랫폼을 닫아 잠가야 합니다. Rev Platform에 직접 부착된 Rev Ladder를 운반하지 마십시오.

Rev Tent 및 Rev Platform의 사용 수명을 연장하려면 텐트와 플랫폼을 사용하지 않을 때 태양과 날씨 요소를 피해 보관하는 것이 좋습니다.

Rev Tent와 Rev Platform을 운송 또는 수면을 위해 차량에 고정할 때 모든 하드웨어를 자주 확인하십시오. Rev 텐트와 플랫폼을 차량에 제대로 고정하지 않으면 부상을 입거나 사망에 이를 수 있습니다. 이 지침을 주기적으로 검토하십시오. 안전한 캠핑카는 행복한 캠핑카!

ZH 在运时，有或没有 Rev 篷的 Rev Platform X，您必须将平台固定在关闭状态。请勿直接连接到 Rev 平台的 Rev Ladder。

为了延长 Rev 篷和 Rev 平台的使用寿命，我建议在不使用时将篷和平台存放在远离阳光和天气因素的地方。

将 Rev 篷和 Rev 平台固定到车上运行或睡眠 - 常时所有硬件。如果未能将 Rev 篷和平台正确固定到车上，可能会致人身伤害甚至死亡。定期看些说明。安全的露营者是一个快乐的露营者!

EL Κατά τη μεταφορά της πλατφόρμας Rev X με ή χωρίς τη σκηνή Rev, ΠΡΕΠΕΙ να κλειδώσετε την πλατφόρμα κλειστή. Μην μεταφέρετε το Rev Ladder απευθείας συνδεδεμένο στην πλατφόρμα Rev.

Για να παρατείνετε τη διάρκεια ζωής της σκηνής Rev και της πλατφόρμας Rev σας, συνιστούμε να αποθηκεύετε τη σκηνή και την πλατφόρμα μακριά από τον ήλιο και τα καιρικά στοιχεία όταν δεν χρησιμοποιούνται.

Όταν στερεώνετε τη σκηνή Rev και την πλατφόρμα Rev σε ένα όχημα για μεταφορά ή ύπνο - ελέγχετε συχνά όλο το υλικό. Αν δεν ασφαλίσετε σωστά τη Σκηνή και την Πλατφόρμα Rev σε ένα όχημα θα μπορούσε να οδηγήσει σε σωματική βλάβη, ακόμη και θάνατο. Διαβάστε αυτές τις οδηγίες περιοδικά. Ένα ασφαλές camper είναι ένας χαρούμενος κατασκηνωτής!

Visit

www.c6outdoor.com

For all instructions, warnings, warranty, specifications and more