

Make: Subaru

Model: 2023+ Outback

Applications: Rally Light Bar

PACKAGE CONTENTS				TOOLS
QTY		QTY		
1	Rally Light Bar	4	5/16" Flat Washer	Flat Head Screwdriver Ratchet (3/8" Drive) 9/16", 1/2" Socket/Wrench 10mm, 12mm Socket Cutting Tool (Blade/Mini Reciprocating Saw) U-Joint Socket Adapter
2	Upper Bracket	2	3/8" - 16 x 2.5" Hex Bolt	
1	Lower Brace	4	3/8" Flat Washer	
2	Round Aluminum Spacer	2	3/8" Lock Washer	
2	40mm M8 Flange Head Bolt	2	3/8" - 16 Hex Nut	
4	5/16" Lock Washer			
2	5/16"-18 x 1" Hex Bolt			

INSTALLATION INSTRUCTIONS

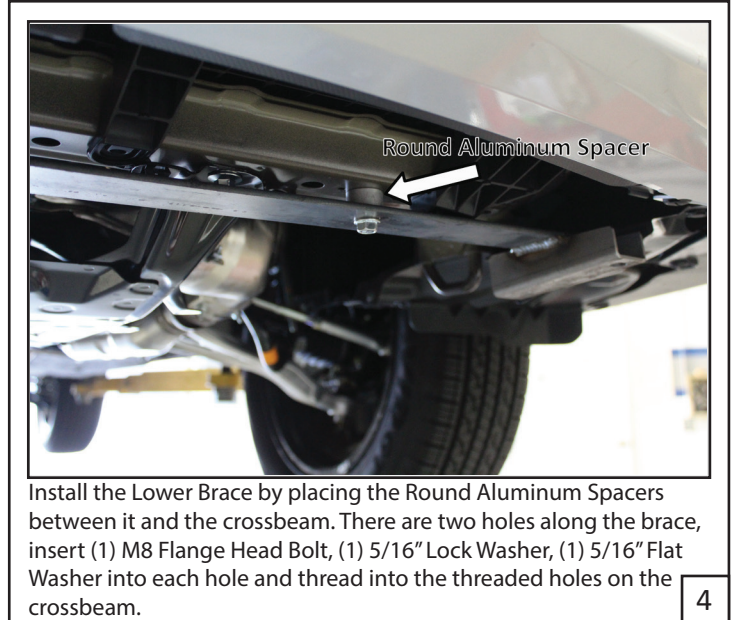
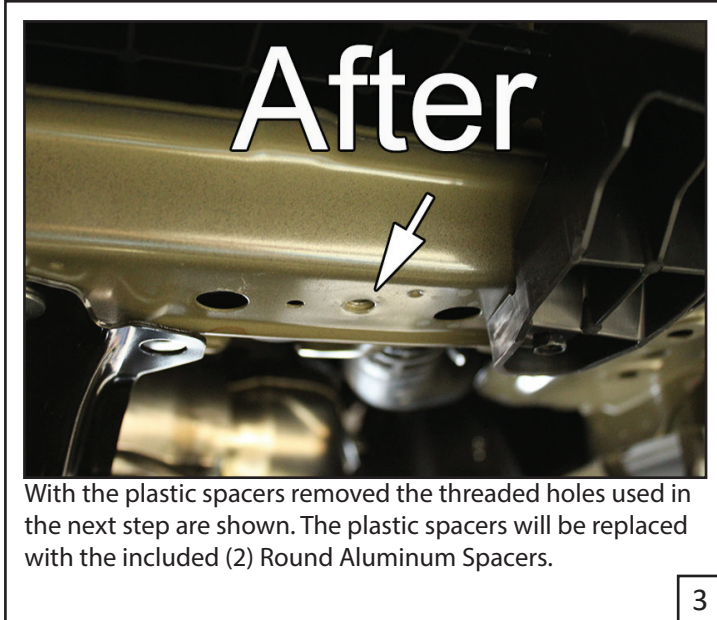
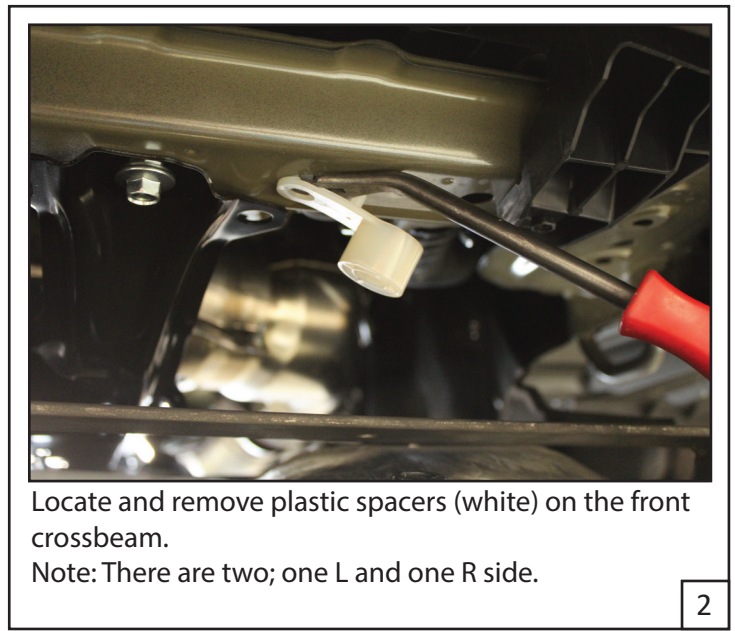
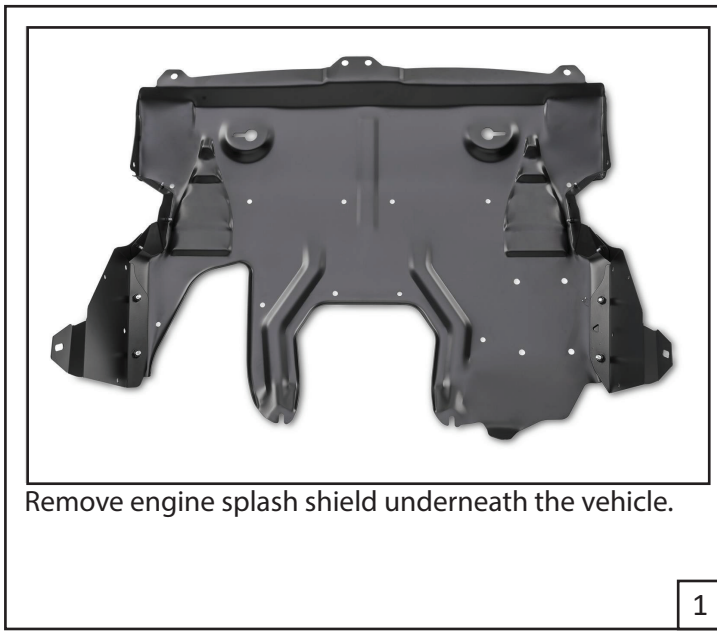

DISCLAIMER FOR RALLY INNOVATIONS PRODUCTS: Buyers assume all risk and liability whatsoever for the installation and the use of Rally Innovations products. Rally Innovations products are sold as decorative accessories and should not be relied upon as protection for the vehicle or occupants in the event of a collision or roll over. Vehicles equipped with a supplemental restraint system (air bag) deployed by impact should not be modified by any aftermarket Light Bar or Skid Guard without first consulting the vehicle manufacturer. Rally Innovations, a subsidiary of Pentech Automotive assumes no liability for injury, loss, incidental or consequential damages in the event of a collision or roll over.

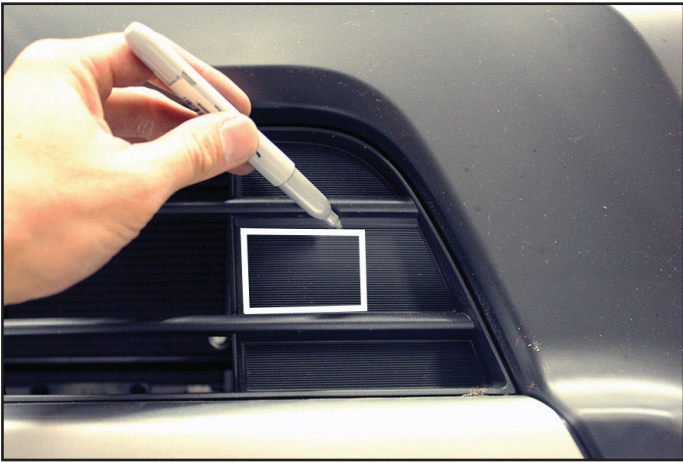

On the bumper cover, cut out the center window on the driverside of the lower grille (outlined above). For Wilderness model refer to the addendum.

5



Remove the factory bolt located behind the grille and set aside for reuse. Repeat on the passenger side.

6

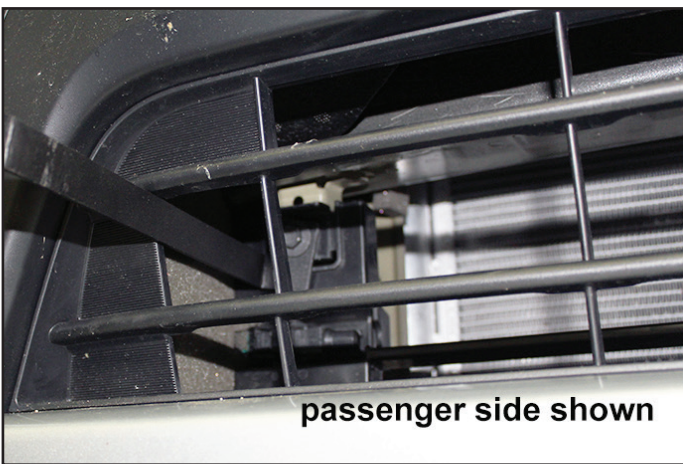

Insert the driverside Upper Bracket into the newly cut hole and fasten it to the factory hole using the original bolt removed in the previous step. Loosely tighten for now. Repeat step on the passenger side. Wilderness model see addendum.

7

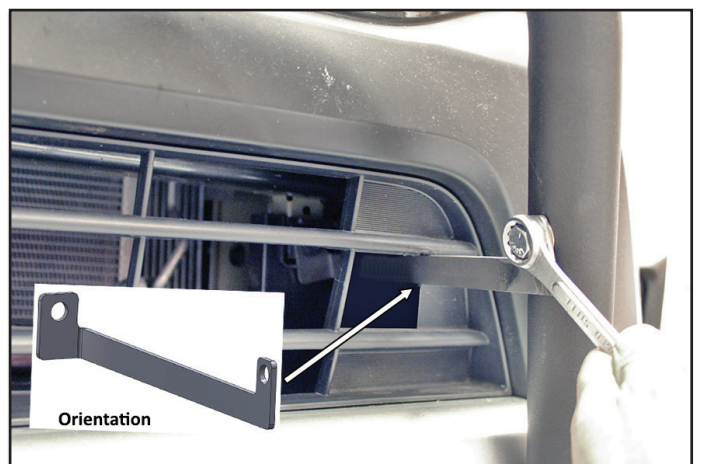

Attach the Light Bar to the Upper Brackets using (1) 5/16"-18x1" Hex Bolt, (1) 5/16" Lock Washer and (1) 5/16" Flat Washer, per side. Tighten down all the bolts. Wilderness model see addendum; orientation is opposite.

8



Attach the Light Bar to the Lower Brace with (1) 3/8" x 2.5" Hex Bolt, (2) Flat Washer, (1) Lock Washer and (1) Nut. Repeat on the passenger side. Tip: If the holes do not line up, try loosening the Flange Head Bolt from Step 4, then try threading the 3/8" x 2.5" Hex Bolt in again. Be sure to tighten the Flange Head Bolts when finished.

9

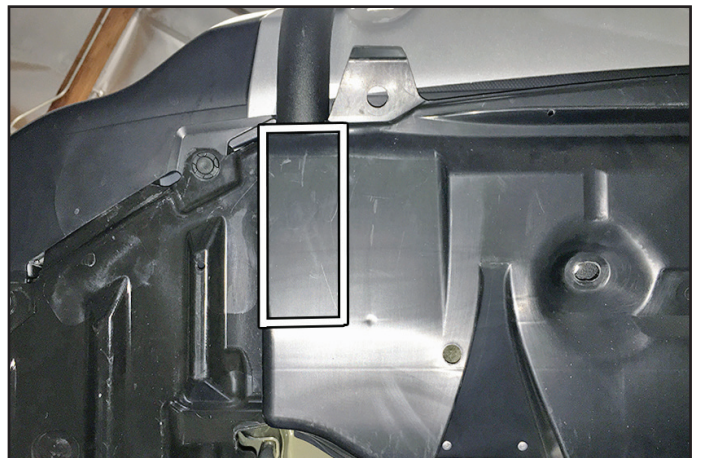

Hold up the engine splash shield to its original location to mark where it needs trimming. A piece roughly the size of the rectangle shown above will need to be cut away to clear the bar when reinstalling the splash shield. Wilderness model see addendum.

10

DISCLAIMER FOR RALLY INNOVATIONS PRODUCTS: Buyers assume all risk and liability whatsoever for the installation and the use of Rally Innovations products. Rally Innovations products are sold as decorative accessories and should not be relied upon as protection for the vehicle or occupants in the event of a collision or roll over. Vehicles equipped with a supplemental restraint system (air bag) deployed by impact should not be modified by any aftermarket Light Bar or Skid Guard without first consulting the vehicle manufacturer. Rally Innovations, a subsidiary of Pentech Automotive assumes no liability for injury, loss, incidental or consequential damages in the event of a collision or roll over.



Reinstall engine splash shield.

11



Completed assembly shown.

12

Addendum for Wilderness model

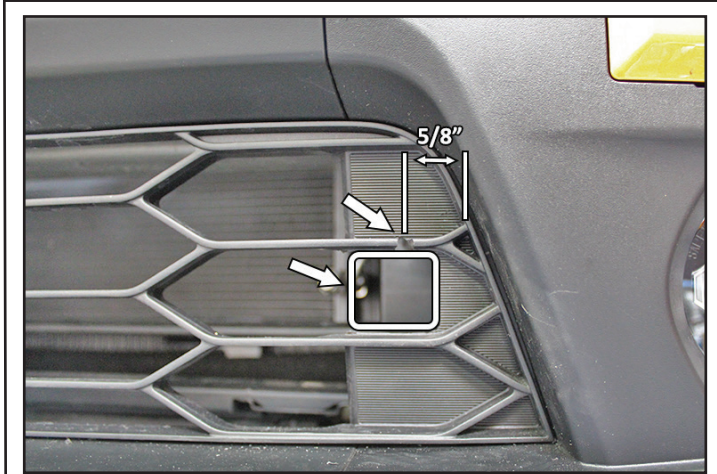

Notch the grille and cut out like shown on the driver side.

1

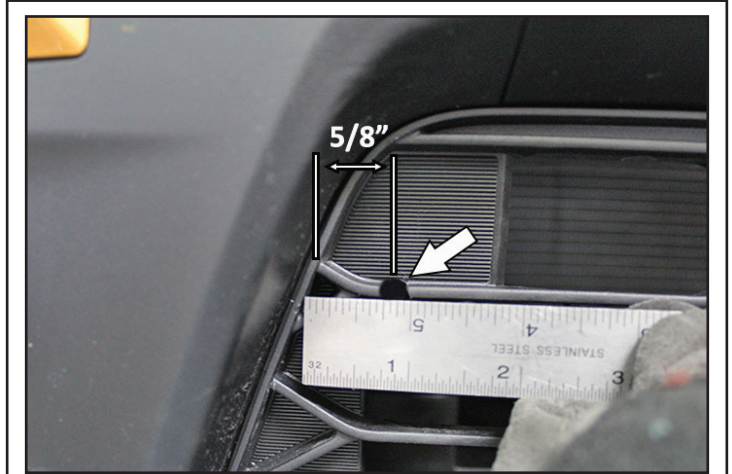

Notch the grille like shown on the passenger side.

2



Attach the upper brackets using the factory M6 (10mm head) bolts. **Optional:** If too difficult to do as shown, cut a hole into the grille panel large enough to insert an extension to fasten the bolt (circle shown).

3



Note the orientation of the upper bracket as shown above. Passenger side shown.

4

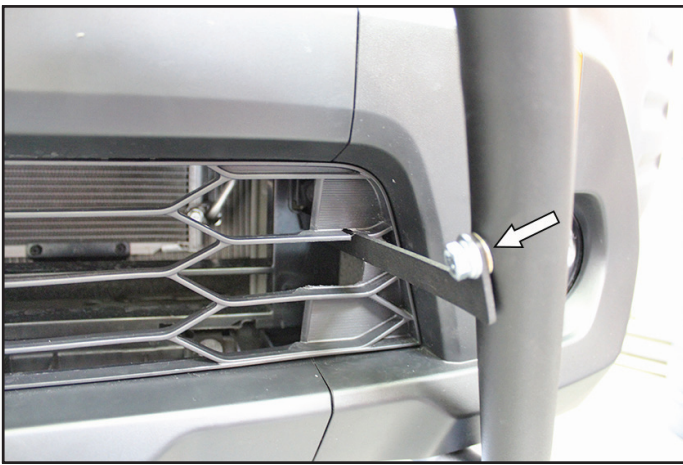

Attach bar to the upper brackets.

5

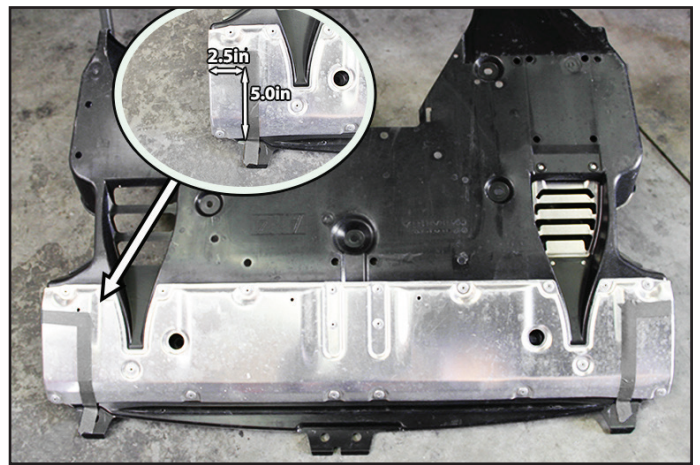

Trim areas marked on the engine splash shield and reinstall.

6

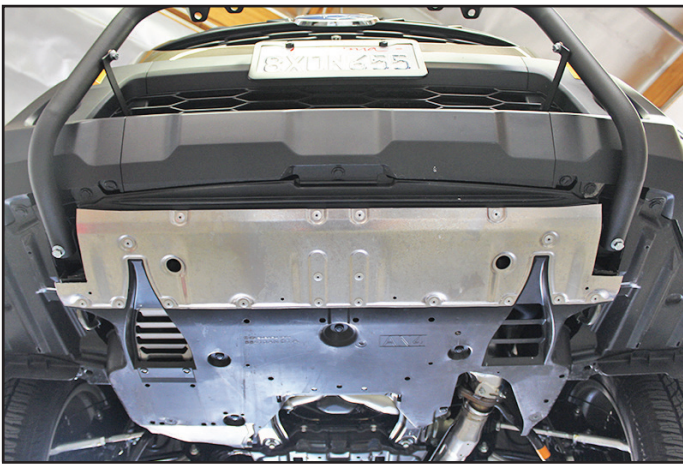

Engine splash shield installed.

7



Completed assembly shown.

8