

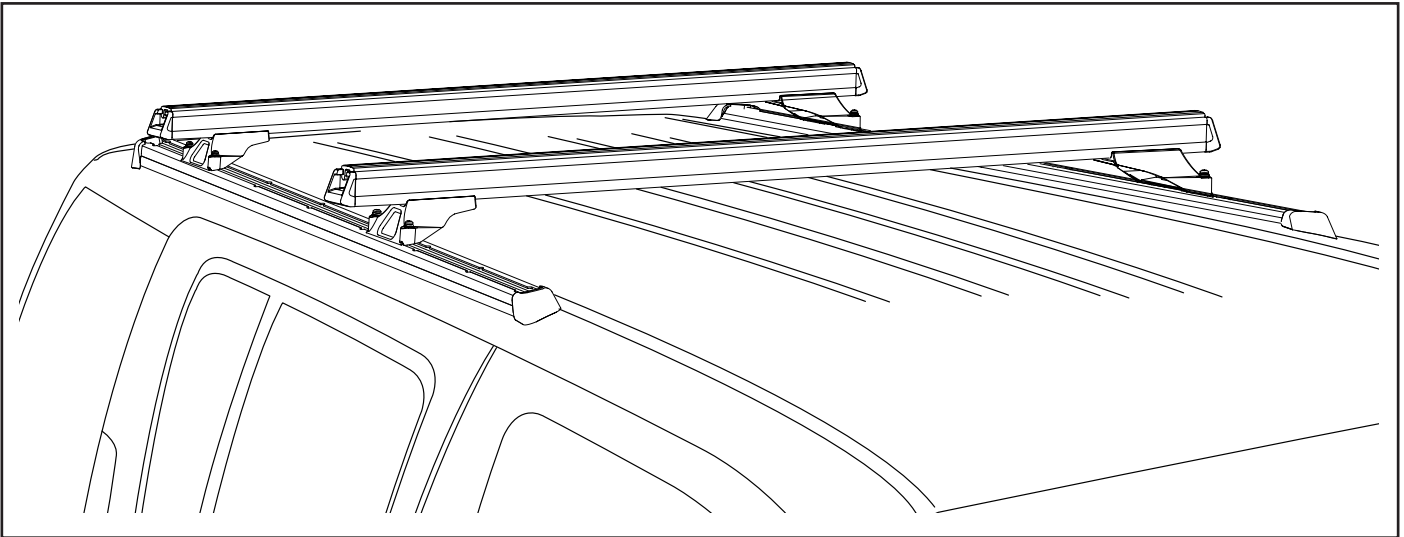

# RHINO-RACK

## RTS506 NISSAN Pathfinder Two Cross Bar Track Mount System

**Important:** Please read these instructions carefully prior to installation.  
Please refer to your fitting instruction to ensure that the roof racks are installed in the correct locations.  
Check the contents of kit before commencing fitment and report any discrepancies.  
Place these instructions in the vehicle's glove box after installation is complete.



**Care Instruction:** Wash vehicle roof prior to installing Rhino Tracks.

### Important Information

**Maximum carrying capacity: 100kg**

**Recommendations:**

It is essential that all bolt connections be checked after driving a short distance when you first install your cross bars. Bolt connections should be checked again at regular intervals (probably once a week is enough, depending on road conditions, usage, loads and distances travelled). You should also check the cross bars each time they are re-fitted.

Make sure to fasten your load securely. Please ensure that all loads are evenly distributed and that the centre of gravity is kept as low as possible.

**Use only non-stretch fastening ropes or straps.**

**Sensitivity to cross winds, behaviour in curves and braking.**

The handling characteristics of the vehicle, changes when you transport a load on the roof. For safety reasons, we recommend you exercise extreme care when transporting wind-resisting loads; special consideration must be taken into account when braking.

**Please remove cross bars when putting vehicle through an automatic car wash.**

**Load Ratings:**

Maximum permissible load is 100kg per pair of cross bars (include the weight of the cross bars, 5kg). When cross bars are to be used in off-road conditions, please build a safety factor of 1.5 into this load limit. Although the cross bars are tested and approved to AS1235-2000, Australian road conditions can be much more rigorous. However, increasing the number of cross bars does not increase the vehicles maximum permissible roof loading.

**Note for Dealers and Fitters:**

It is your responsibility to ensure instructions are given to the end user or client.

Rhino-Rack  
3 Pike Street, Rydalmere,  
NSW 2116, Australia.  
(Ph) (02) 9638 4744  
(Fax) (02) 9638 4822

Document No: RR-149  
Prepared By: Craig Jones  
Authorised By: Chris Murty

Fit Time: 45min  
Issue No: 05  
Issue Date: 24/10/2017

These instructions remain the property of Fetovu Pty Ltd T/as Rhino-Rack and may not be used or changed for any other purpose than intended.



# RTS506 NISSAN Pathfinder Two Cross Bar Track Mount System

## Parts List

Item	Component Name	Qty	Part No
1	Rubber End Cap FL/RR	2	M277
2	Rubber End Cap FR/RL	2	M278
3*	Track 1720mm Right	1	A313
4*	Track 1720mm Left	1	A313
5	Rubber Track Strip 1720mm	2	R045
6*	Heavy Duty Rubber Buffer 1375mm	2	R004
7*	Heavy Duty Crossbar End Cap	4	M002
8*	Heavy Duty Crossbar 1375mm	2	A020
9*	M10 Channel Nut	4	N024
10	Swivel Adaptor	2	M292
11*	M6 x 35mm Button Security Screw	8	B092
12*	M6 Spring Washer	8	W004
13*	M6 x 12.5mm Flat Washer	8	W003
14*	RLTP Track Mount Leg	4	M057
15*	M6 x 21.43mm Brass Hex Nuts	8	N009
16*	M10 x 38mm Flat Washer	4	W022
17*	M10 Internal Shakeproof Washer	4	W021
18	M10 x 35mm Hex Bolt	2	B079
19*	M10 x 25mm Hex Bolt	2	B071
20	Rivet 5mm	20	H060
21*	5mm Security Allen Key	1	SECKEY-S
22*	Butyl Patches	21	CA1397
23*	RLTF Wedge	8	M148
24	M6 x 45mm Hex Stescrew	2	B123
25	Fitting Instruction	1	RR149

### Tools Required:

Pneumatic or Concertina  
Rivet gun.  
Masking tape.  
Rubber Mallet.  
Power or Cordless drill.

Vacuum cleaner.  
Cold galvanizing  
solution & small brush.  
Drill Stop  
5mm drill bit.

\* Note: Parts sold as separate in the corresponding RLTF Leg kit and RB Crossbar kit.  
Item 24 to be used for Vortex Bar fittings with VAFK1.

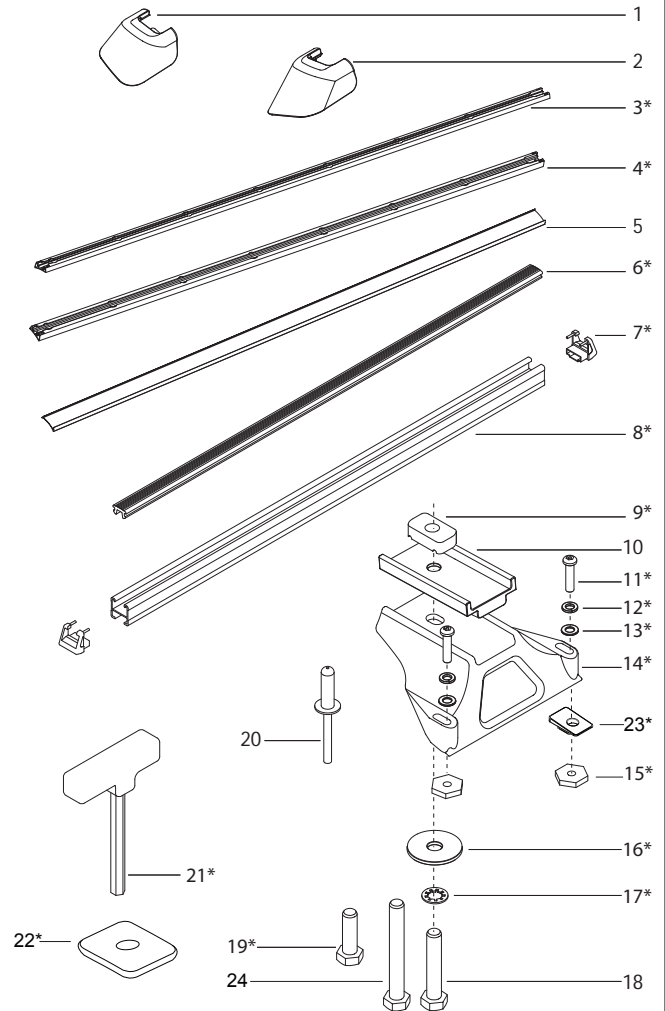

1

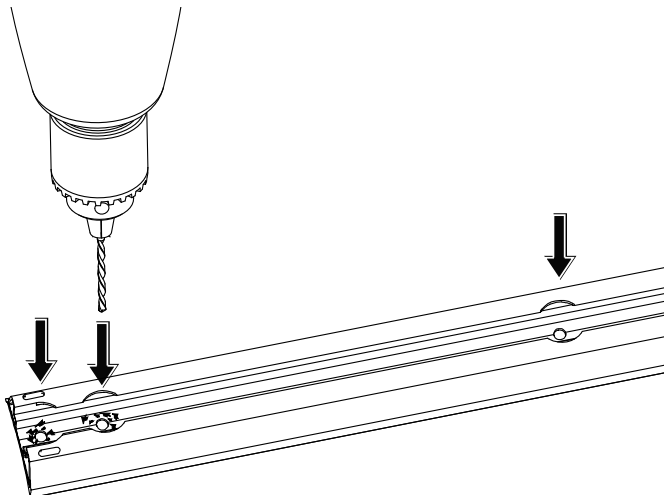

Holes need to be drilled through the rubber strip to allow the rivets to be pushed through. Make sure the end of the Track and Rubber strip are aligned before drilling. Using the Track extrusion holes as a guide, carefully drill through the rubber strip **with a 5mm drill bit only**.



## RTS506 NISSAN Pathfinder Two Cross Bar Track Mount System

2

Long edge,  
Outside of vehicle.

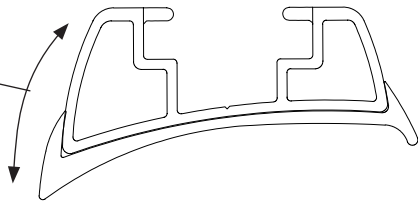

The Track extrusions are Left and Right handed. Each Track has two large cut outs at one end, this denotes the **FRONT** of the vehicle. The single large cut out denotes the **REAR**.

LEFT Track Front →



Large cut out  
**REAR**

TOP view

Two large cut outs  
**FRONT**

RIGHT Track Front →



**NOTE: WE RECOMMEND THAT YOU COMPLETELY INSTALL ONE TRACK AT A TIME.**

3

- Position the Front of the Track in line with the Front/Rear door jamb as shown.
- The inside lip of the Rubber strip must locate firmly against the roof channel radius.
- Person one (**P1**) and with the assistance of a second person (**P2**) hold the Track/Rubber assembly firmly against the outer roof channel radius. Spot drill the first six holes. (**P2**) Hold the Track and maintain alignment of the sixth hole as (**P1**) moves around towards the rear of the Track. (**P2**) and (**P1**) pull the rear of the track firmly against the outer roof channel radius while maintaining sixth hole alignment and (**P1**) to continue spot drilling holes 7 - 10.

**NOTE: (P1)** refers to the person drilling.  
**(P2)** refers to the person assisting.

a.

Align FRONT of  
Track with door jamb.

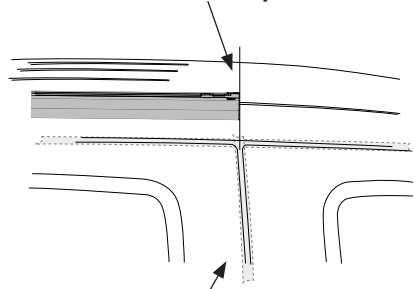

Use masking tape around door and window seals to prevent drill swarf entering these areas.

b.

Maintain downwards  
pressure on Track.

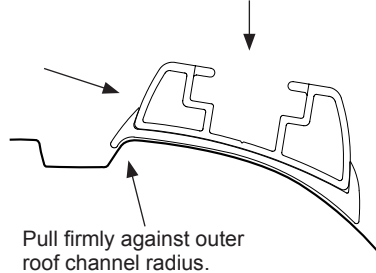

Pull firmly against outer  
roof channel radius.

OUTSIDE of vehicle.

c.

10th.

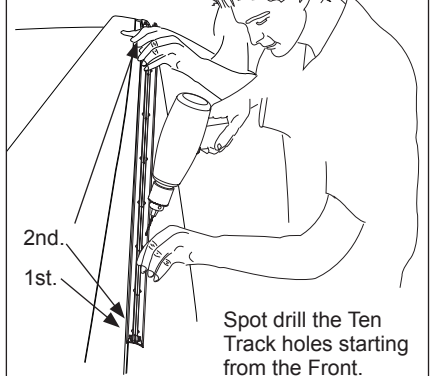

2nd.  
1st.

Spot drill the Ten  
Track holes starting  
from the Front.

4

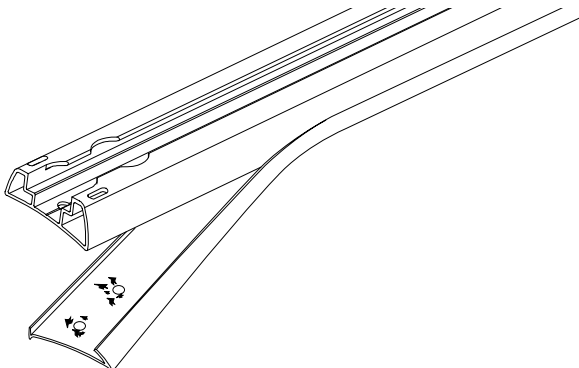

Remove Rubber strip and thoroughly clean out the swarf trapped between it and the Track extrusion. Re-attach the Rubber strip making sure the edges do not fold under. Avoid creasing the Rubber strip.



# RTS506 NISSAN Pathfinder Two Cross Bar Track Mount System

5

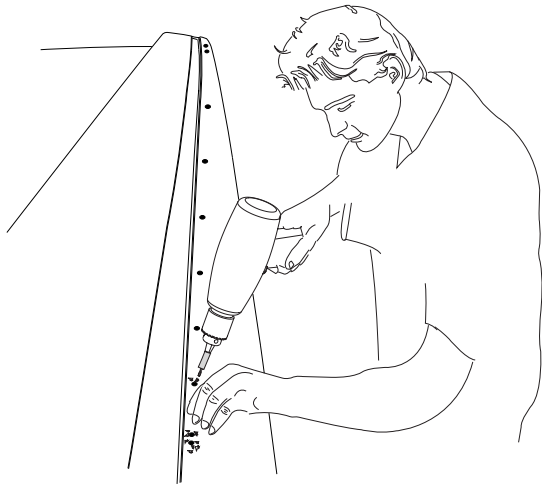

All ten holes can now be drilled through. **Make sure that when drilling you hold the drill perpendicular to the roof angle.** The roof skin is approx. 1-2mm thick.

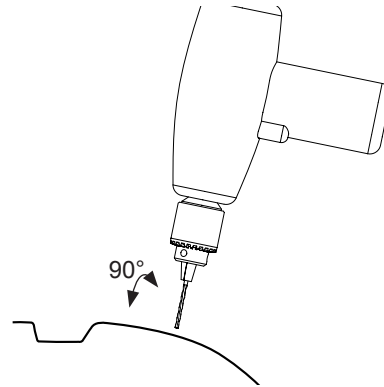

6

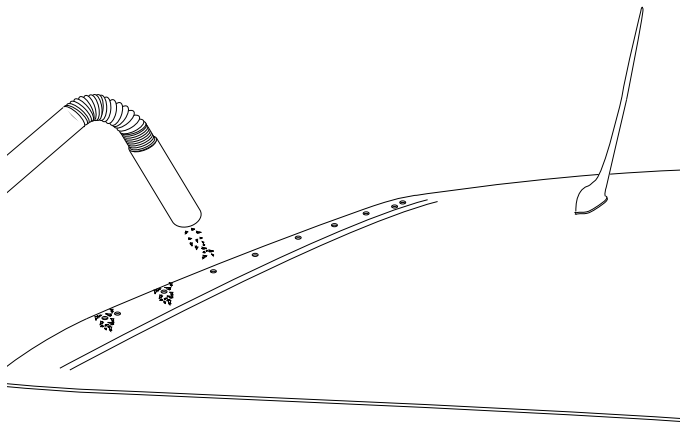

Use a vacuum to remove swarf to eliminate scratching. Wipe clean the installation area of the roof.

7

FL/RR

FR/RL

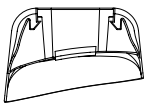

Rubber End Caps

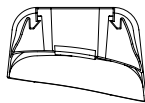

FR/RL

FL/RR

FL/RR

FR/RL



Fit the rubber End caps to the Tracks. The End caps are marked on the underside to denote their position.

FL/RR: Front Left track and Rear Right track.  
FR/RL: Front Right track and Rear Left track.

For ease of End cap installation use WD-40 to lubricate the locating fingers. Push the fingers through the slots in the Track.

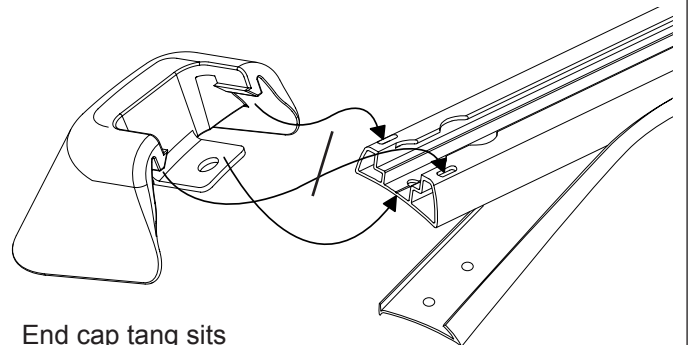

End cap tang sits between Track extrusion and rubber strip.



# RTS506 NISSAN Pathfinder Two Cross Bar Track Mount System

**8**

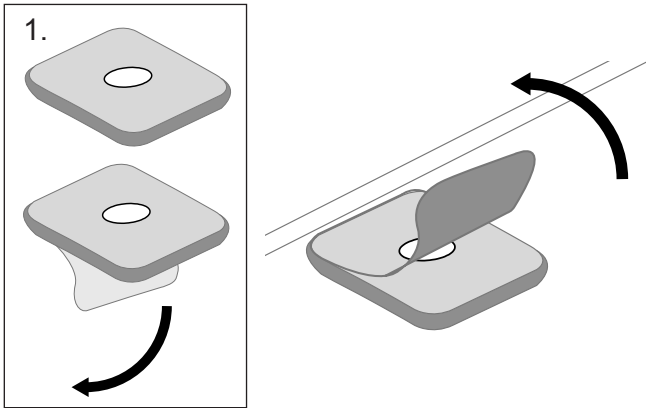

- 1: Remove the backing tape from the Butyl Patches.
- 2: Place over holes drilled. Once in place remove the rest of the protective tape from the top of the patches.

**9**

Left side shown. FL/RR end cap.

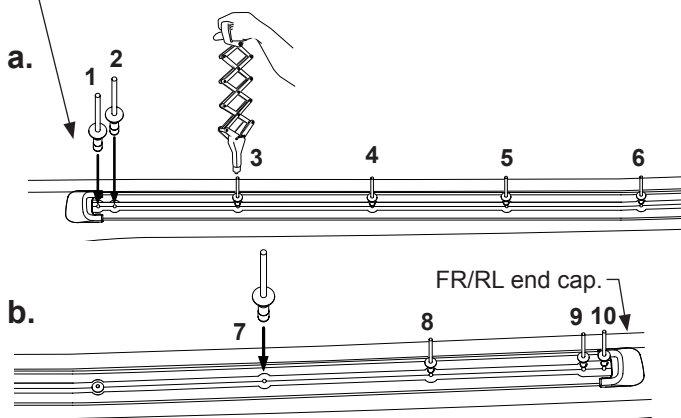

- a. **FRONT:** Line up and place the first six rivets in their respective holes. Rivet the first **6 holes** only at this stage starting from the front. While riveting have the second person maintain pressure on the track to hold it against the roof channel radius as shown in diagram **3b**.
- b. **REAR:** Line up and place the last four rivets in their respective holes, starting at the **7th hole** attach the rivets. While riveting have the second person maintain pressure on the track to hold it against the roof channel radius as shown in diagram **3b**.

**10**

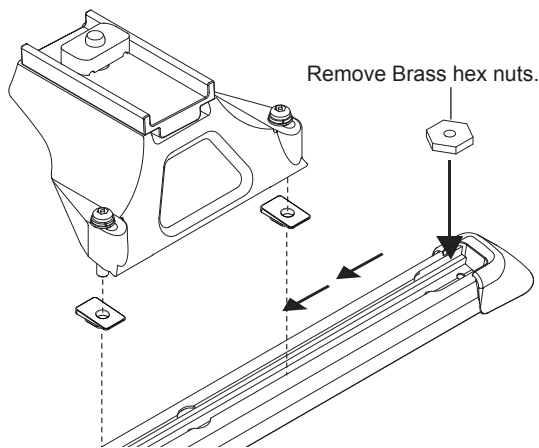

Unscrew the Brass hex nuts from the RLTP leg. Place the Hex nuts off each RLTP leg into the large cut out at REAR of Track and slide along to desired position. The legs will be fitted in place after the cross bars are attached.

**11**

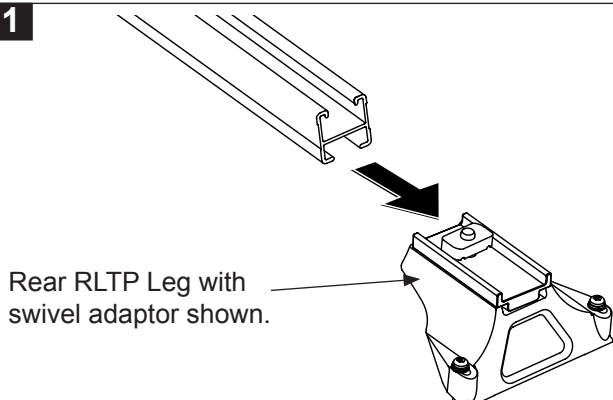

Slide the cross bar onto the leg and locate with the M10 channel nut. Leave untensioned at this stage.

**Rear two RLTP Legs only use the Swivel adaptor as shown.**



# RTS506 NISSAN Pathfinder Two Cross Bar Track Mount System

12

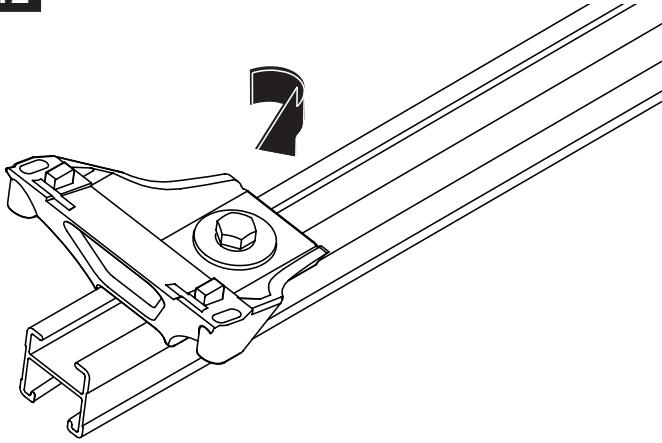

Finger tighten the leg attachment bolt so that the channel nut turns to locate across the cross bar. Leave loose enough so the cross bar can slide along the leg. The legs will require final adjustment and tightening later.

Front RLTP Leg shown.

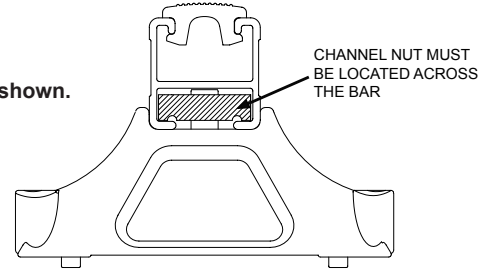

13

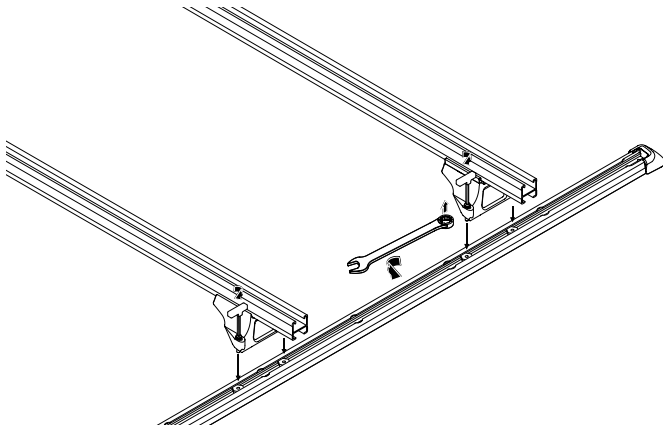

Locate the RLTP legs onto the tracks then fasten M6 security screws into the brass hex nuts. Leave loose for adjusting the legs and cross bars along the Track extrusion.

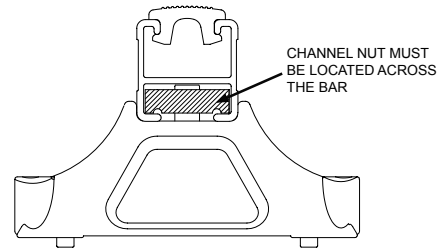

14

Once the leg and cross bar assemblies are in position use a tape measure to check the cross bar over hang is equal on both sides, re-adjust if required. Tighten the M6 security screws to **3-4N/m**. Tighten the M10 cross bar bolts to **5-6 N/m**.

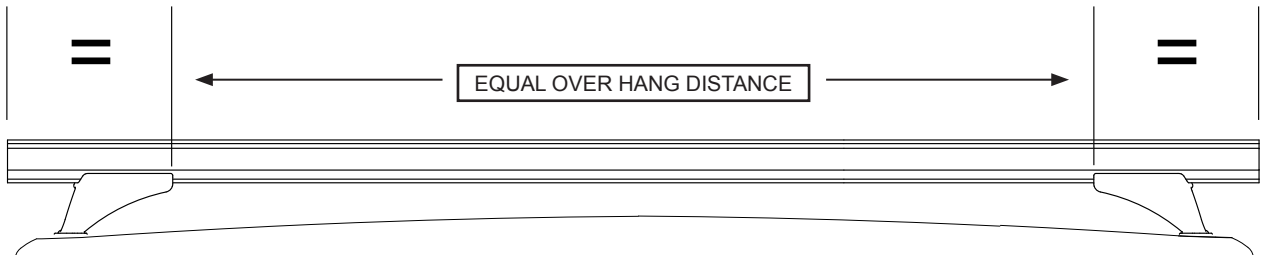

15

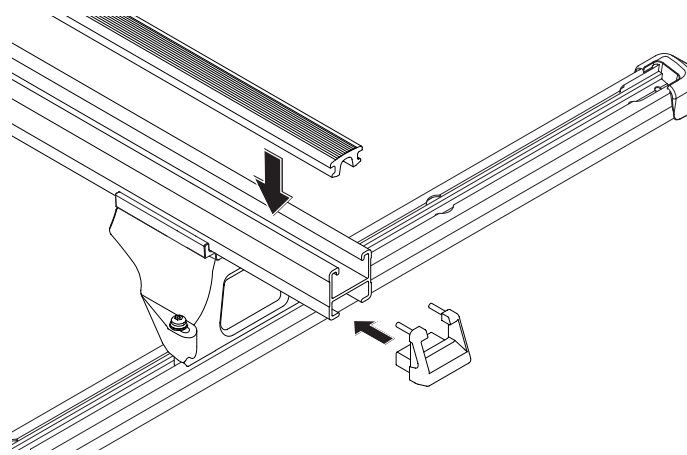

Insert the cross bar rubber buffer strip into the top of the cross bar. Insert the end caps into the ends of the crossbar, a rubber mallet may be required to fit the end caps.