

**CONTROLLED**

RHINO-RACK

RCP43-BK Chevrolet Tahoe, Suburban, GMC Yukon/ Yukon XL,
Cadillac Escalade/ Escalade ESV

Important: Please read these instructions carefully prior to installation.
Please refer to your fitting instruction to ensure that the roof racks are installed in the correct locations.
Check the contents of kit before commencing fitment and report any discrepancies

Layout

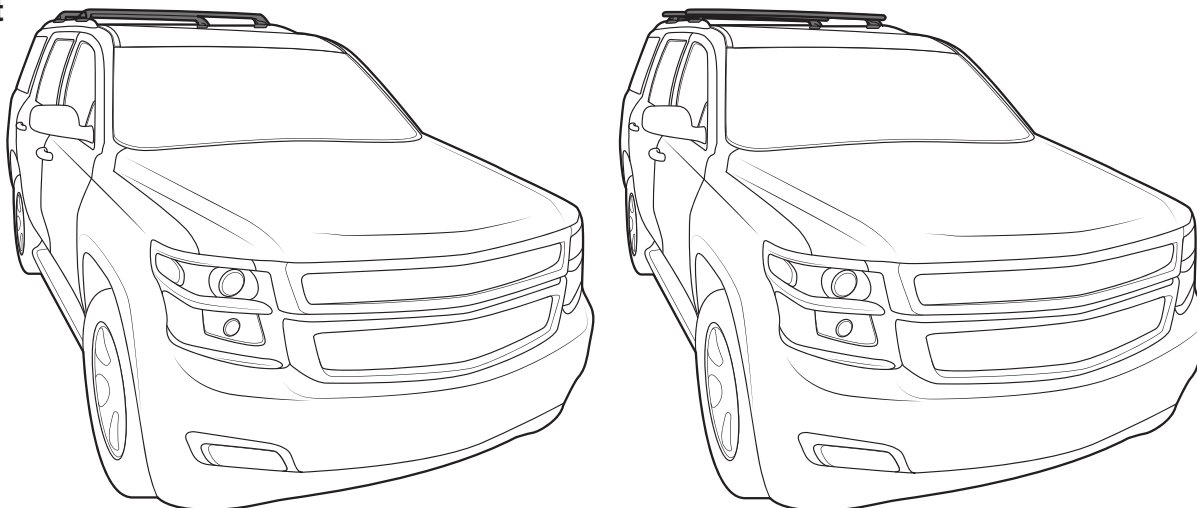

Note: Crossbars and legs sold as separate.

Important Information.

1. Check Part No./Kit is correct
2. Read through instruction before installing
3. Fit roof rack accessory
4. Check and recheck all fasteners are secure

Maximum carrying capacity: 100kg (220lbs) evenly distributed over the two/ three cross bars. Note: Be sure to check the Rhino-Rack website to see if you have the latest version of instructions before beginning installation.

Recommendations:

It is essential that all bolt connections be checked after driving a short distance when you first install your cross bars. Bolt connections should be checked again at regular intervals (probably once a week is enough, depending on road conditions, usage, loads and distances travelled). You should also check the cross bars each time they are refitted.

Be sure to fasten load securely. Please ensure that all loads are evenly distributed and that the centre of gravity is kept as low as possible. **Use only non-stretch fastening ropes or straps.**

Sensitivity to cross winds, behaviour in curves and braking.

The handling characteristics of the vehicle changes when you transport a load on the roof. For safety reasons, we recommend you exercise extreme care when transporting wind-resisting loads; special consideration must be taken into account when braking. **Please remove cross bars when putting vehicle through an automatic car wash.**

Load rating.

Maximum permissible load is 100kg (220lbs) per pair of cross bars (include the weight of the roof racks, 5kg). When crossbars are to be used in off-road conditions, please build a safety factor of 1.5 into this load limit. (66kg/145lbs for off-road use). Although the roof racks are tested and approved to AS1235-2000, Australian road conditions can be much more rigorous. However, increasing the number of cross bars does not increase the vehicles maximum permissible roof loading.

Note for Dealers and Fitters.

It is your responsibility to ensure instructions are given to the end user or client.

Rhino-Rack
3 Pike Street, Rydalmere,
NSW 2116, Australia.
(Ph) (02) 9638 4744
(Fax) (02) 9638 4822

Document No: R1343
Prepared By: Kayle Everett
Authorised By: Chris Murty

Fit Time: 30min
Issue No: 01
Issue Date: 24/04/2017

These instructions remain the property of Rhino Rack Australia Pty. Ltd. and may not be used or changed for any other purpose than intended.

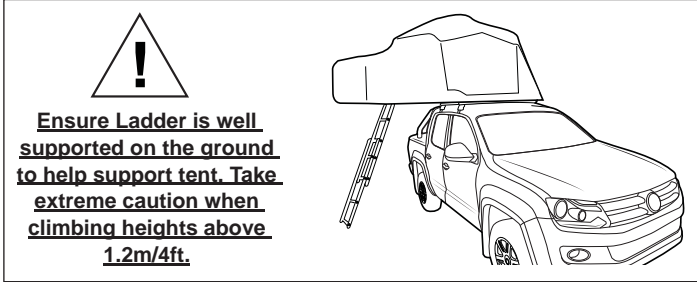
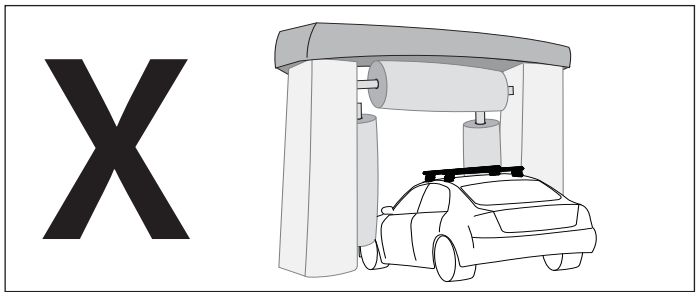
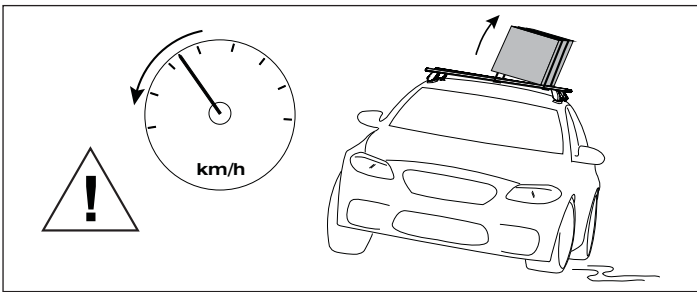
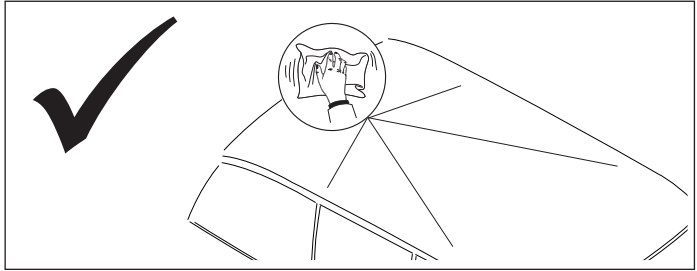
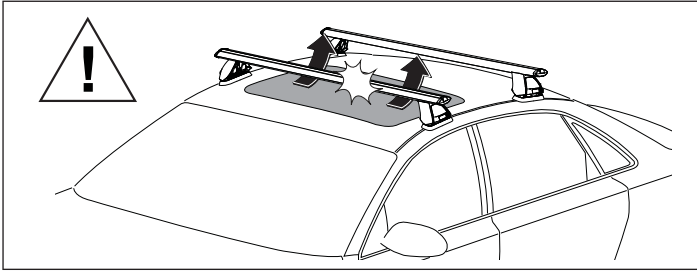
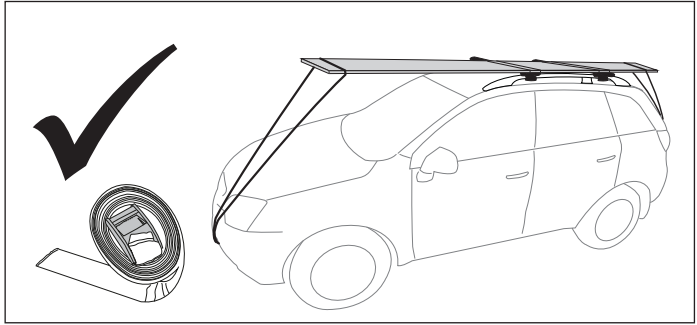
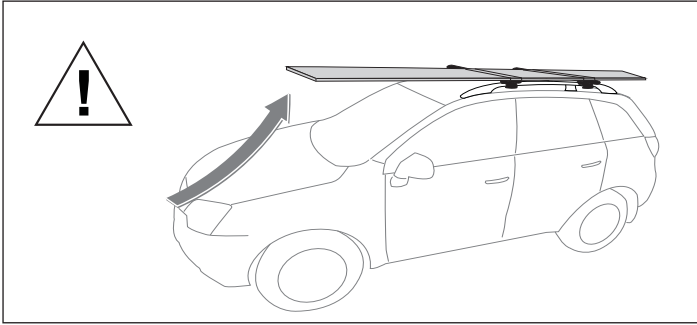

Ensure Ladder is well supported on the ground to help support tent. Take extreme caution when climbing heights above 1.2m/4ft.

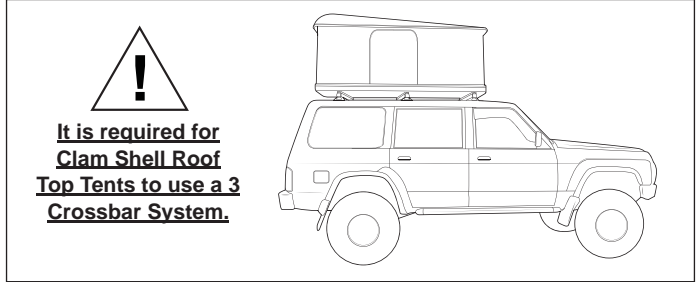

It is required for Clam Shell Roof Top Tents to use a 3 Crossbar System.

When these roof racks are to be used on a vehicle that is driven off sealed roads the maximum load rating must be divided by 1.5. Remember to subtract the weight of the roof racks to determine your maximum permissible load capacity.

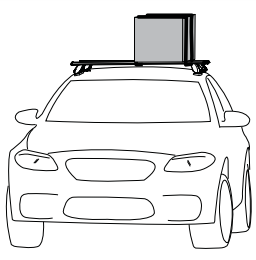

2 bars 100kg (220lbs) load rating (Urban road) = 2 bars 66kg (145lbs) load rating (Off road)
Load rating not taking into account crossbar weight - 5kg

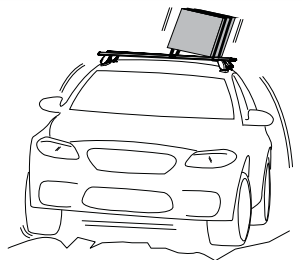

WARNING! Important Load Carrying Instructions

With utility vehicles, the cabin and the canopy move independently. Roof racks and vehicle can be damaged if the item transported is rigidly fixed at points on both the cabin and canopy. Instead, rigidly fix to either the cabin roof racks or the canopy roof racks.

Paddle/ Surfboards should be fixed to the front of the vehicle.



Parts List.

Item	Component Name	1 bar	2 bar	Part No.
1	M6 x 16mm Cap Head Screw	4	8	B031
2	M6 Spring Washer	6	12	W004
3	M6 x 12.5mm Flat Washer	4	8	W003
4	M6 x 16mm Flat Washer	2	4	W031
5	RLCP Bracket	2	4	CA1536
6	Rubber Skirt	2	4	M725
7	M6 x 16mm Hex Setscrew	2	4	H021
8	Cover Plate	2	4	M168
9	Allen Key	1	1	H021
10	M6 Washer (used on cover plate)	2	4	W003
11	Instructions	1	1	R1343

Tools Required:
10mm socket wrench.
Torx Key.

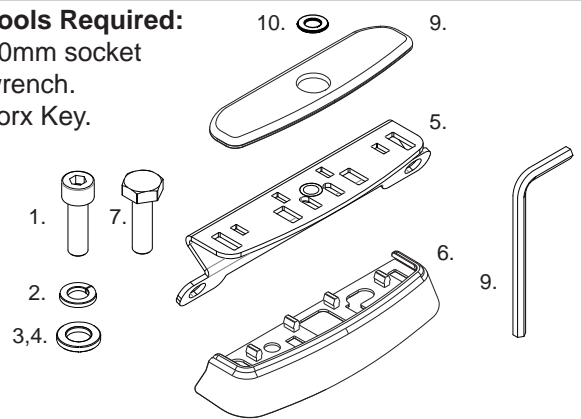

Instructions.

1 Locate the Thread Protection Caps on the inside on the elevated rails of the vehicle. Remove the caps where you intend to install Crossbars. Note: If Factory Rails are installed, remove with a Torx Head Key or Drill.

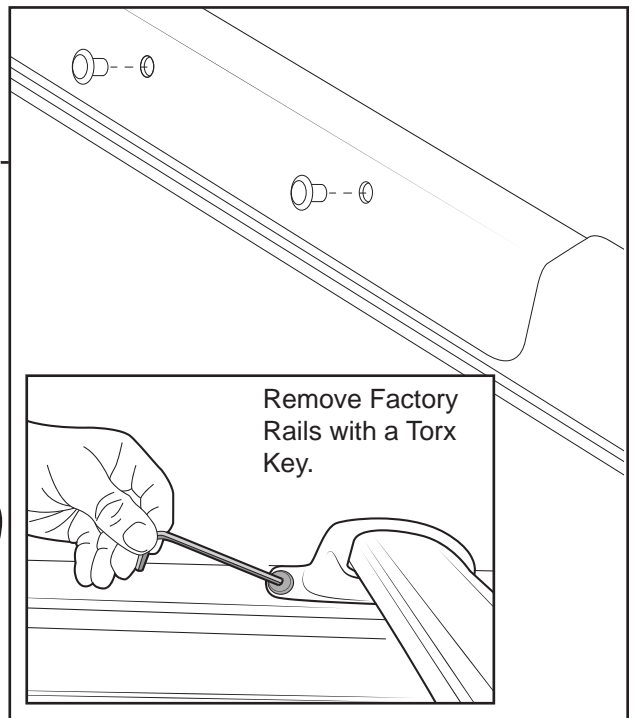
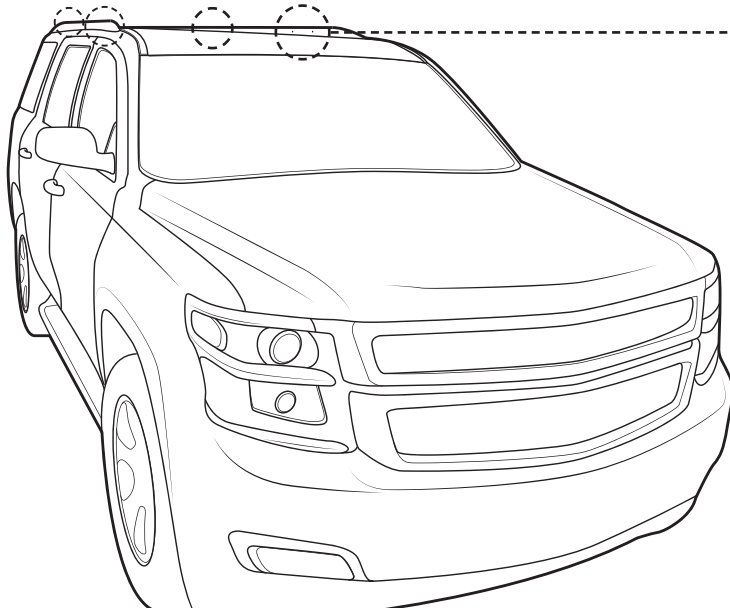

2 Select the appropriate Crossbar positions on your vehicle.

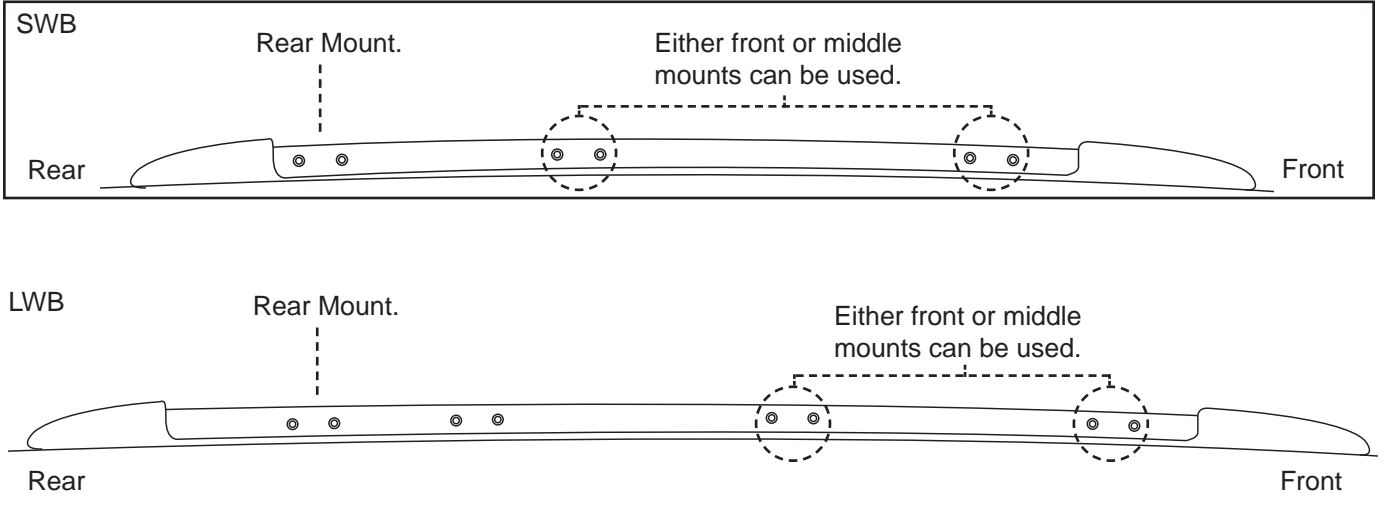



3 Install the RLCP Bracket onto the Rubber Skirt. Note that the four locking points on the Rubber Skirt push through and fix onto the Bracket.

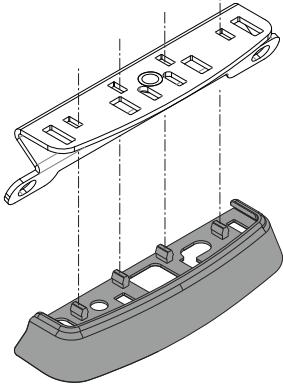

Locking points push through and fix onto Bracket.

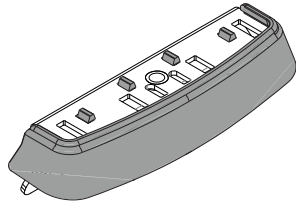

4 Install the Brackets using the M6 Hardware as shown.

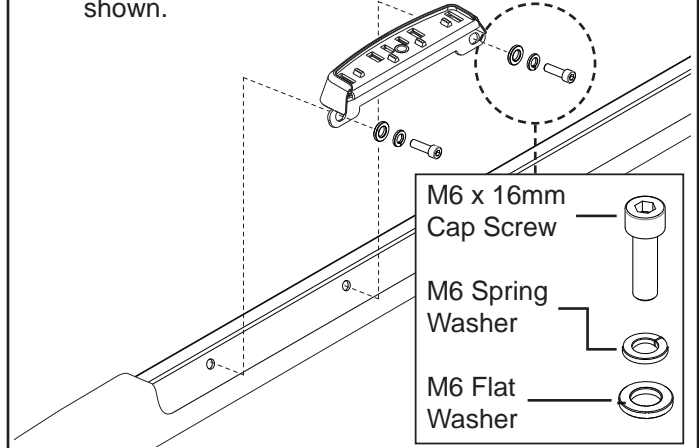

5 When crossbars are not in use, remove and install the pad cover plates as shown.

M6 x 16mm Hex

M6 Spring Washer

