

RCI 22+ TOYOTA TUNDRA DOUBLECAB ROCK SLIDER INSTALLATION GUIDE

****This install guide is applicable to our 22+ Toyota Tundra DoubleCab 6.5ft Bed Rock Slider ONLY****

ITEM NO.	PART NUMBER	DESCRIPTION	QTY.	
1	Tundra Slider DCSB	Pair	1	
22	5.16 Carriage Bolt Plate R7	Hardware (RCI)	3	
23	3.8 Carriage Bolt Plate R8	Hardware (RCI)	2	
24	Question Mark Carriage Bolt Plate	Hardware (RCI)	5	
25	.25ms Tundra Frame Bottom Bolt Plate M8 R2	Hardware (RCI)	2	
26	M8 x 30mm Mounting Bolt	Hardware	8	
27	.3125 STEEL FLAT WASHER	Hardware	7	
28	.3125 x 5.5 Carriage Bolt	Hardware	3	
29	5/16 Hex Nut	Hardware	3	
30	5/16 Split Lock Washer	Hardware	3	
31	Full Moon Washer	Hardware	10	
32	3/8 Hex Nut	Hardware	6	
33	3/8 Split Washer	Hardware	6	
34	3/8 Washer	Hardware	6	
35	0.375 x 5.5 Carriage Bolt	Hardware	2	
36	7/16 Flat Washer	Hardware	5	
37	7/16" Split-Washer	Hardware	5	
38	7/16" Hex Nut	Hardware	5	
39	7/16 x5.5 in Carriage Bolt	Hardware	5	
40	3/8 x 4" Carriage Bolt	Hardware	4	
41	.3125x1.25 Flat Washer	Hardware	4	

2

1

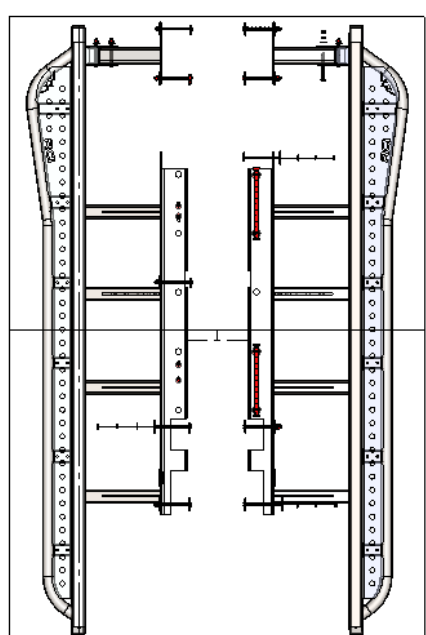

<p>UNLESS OTHERWISE SPECIFIED:</p> <p>DIMENSIONS ARE IN INCHES</p> <p>TOLERANCES:</p> <p>FRACTIONAL ±0.010</p> <p>ANGULAR: BEND ±0.5</p> <p>TWO PLACE DECIMAL ± 0.015</p> <p>THREE PLACE DECIMAL ± 0.010</p> <p>PROPRIETARY AND CONFIDENTIAL</p> <p>THE INFORMATION CONTAINED IN THIS DRAWING IS THE SOLE PROPERTY OF RCI Offroad. ANY REPRODUCTION IN PART OR AS A WHOLE WITHOUT THE WRITTEN PERMISSION OF RCI Offroad IS PROHIBITED.</p>	<table border="1" style="width: 100%; border-collapse: collapse;"> <tr> <th>NAME</th> <th>DATE</th> </tr> <tr> <td>DRAWN KL</td> <td>05/04/23</td> </tr> <tr> <td>SOURCE HiTech</td> <td></td> </tr> </table>	NAME	DATE	DRAWN KL	05/04/23	SOURCE HiTech		<p>RCI OFFROAD</p> <p>TITLE:</p> <p style="font-size: 1.2em;">22+ Tundra Slider Assembly Double Cab R1 - Shipping</p>	<p>Export Date</p> <p style="font-size: 1.2em;">5/8/2023</p>
NAME	DATE								
DRAWN KL	05/04/23								
SOURCE HiTech									
		<div>Item Number BOM</div> <div>Sku</div> <div>REV 1</div>							
		DO NOT SCALE DRAWING	SCALE: 1:20 WEIGHT:						
		SHEET 1 OF 24							

This installation is physically demanding and time intensive. It is highly recommended to recruit a friend or family member to assist in this installation and plan to spend 2-4 hours installing the sliders.

HARDWARE SUBASSEMBLIES:

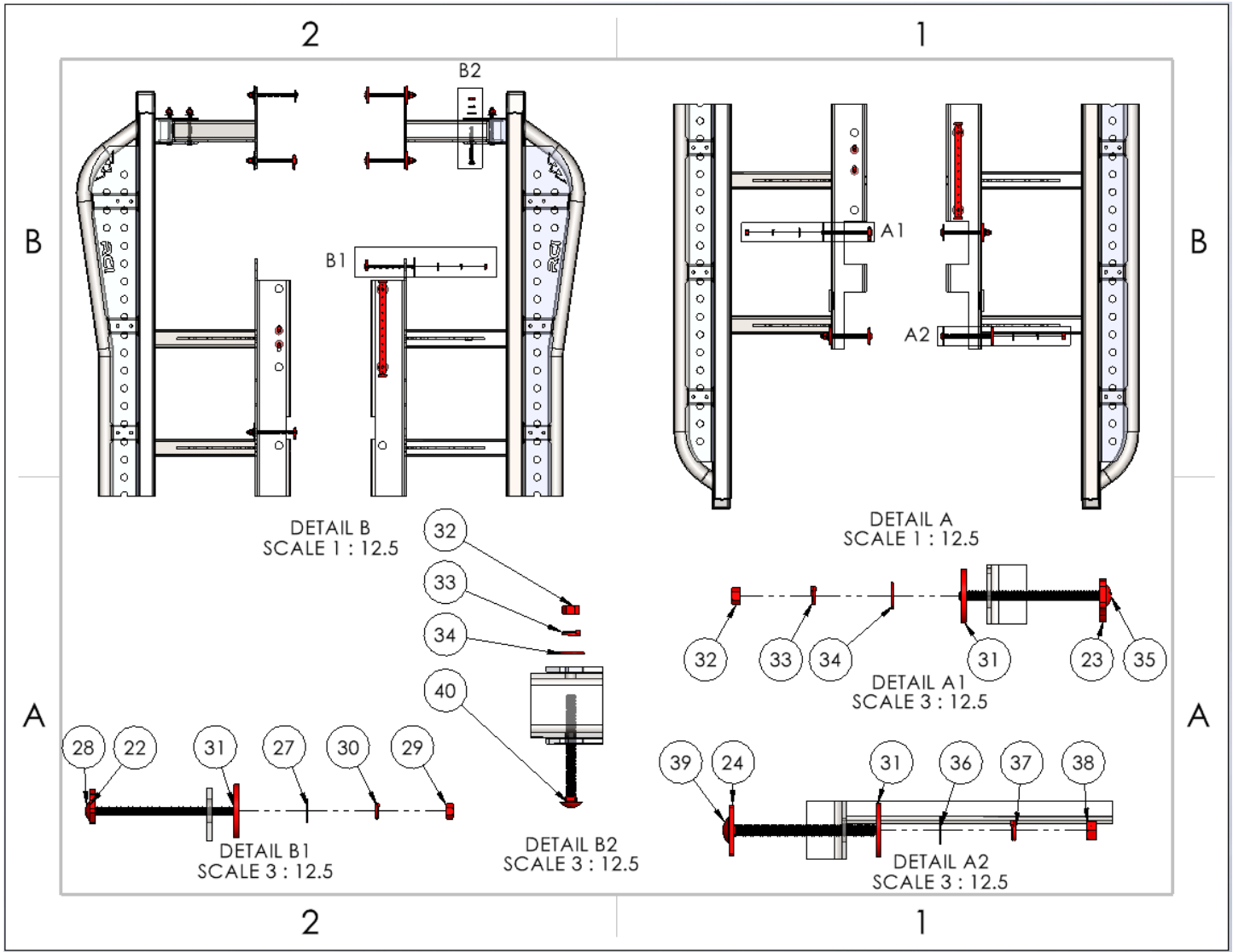

This install guide may refer to various hardware subassemblies. Please refer to the above figure for clarification if necessary.

- Detail B1 – 5/16" frame plate carriage bolt hardware order:
 - 5/16" x 5.5" bolt > 5/16" carriage bolt plate > vehicle frame > slider frame plate > "full moon" washer > 5/16" flat washer > 5/16" split lock washer > 5/16" nut
- Detail B2 – 3/8" bolt on leg hardware order:
 - 3/8" x 4" bolt > slider bolt on leg mount > bolt on leg > slider bolt on leg mount > 3/8" flat washer > 3/8" split lock washer > 3/8" nut
- Detail A1 – 3/8" frame plate carriage bolt hardware order:
 - 3/8" x 5.5" bolt > 3/8" carriage bolt plate > vehicle frame > slider frame plate > "full moon" washer > 3/8" flat washer > 3/8" split lock washer > 3/8" nut
- Detail A2 – 7/16" frame plate carriage bolt hardware order:
 - 7/16" x 5.5" bolt > 7/16" carriage bolt plate > vehicle frame > slider frame plate > "full moon" washer > 7/16" flat washer > 7/16" split lock washer > 7/16" nut

INSTALLATION STEPS:

****Use hand tools, impact wrenches may cause damage if over torqued.**

- 1. Begin by unpacking and removing all components and hardware. Please verify that all hardware, components, and mounting components are present. Please reference your original order invoice and verify all items are accounted for.**
- 2. On the passenger side of the vehicle frame, remove all hardware/accessories that may interfere with the slider installation.**
 - a. M8 Bolt securing a grounding wire approximately 2/3rd of the way back from the front of the front door on the passenger side of the vehicle.**



- b. The plastic caps along the inside and outside of the frame must be removed before starting this installation.**
- 3. Identify the passenger side slider and lift it up to the frame on the passenger side of the vehicle.**
 - a. Use of a floor jack or similar equipment will make this process significantly easier.**
 - b. Take special care to avoid pinching the front grounding wire, its mounting clip, the plastic wire harness mount, and/or any other frame-mounted wires and lines.**
 - c. The plastic wire harness mount should sit on the outside of the slider frame plate, NOT between the frame and the slider frame plate.**

4. Align the holes in the slider frame plate with the holes in the vehicle frame. For the passenger side, we are primarily concerned with these holes aligning with those on the vehicle:

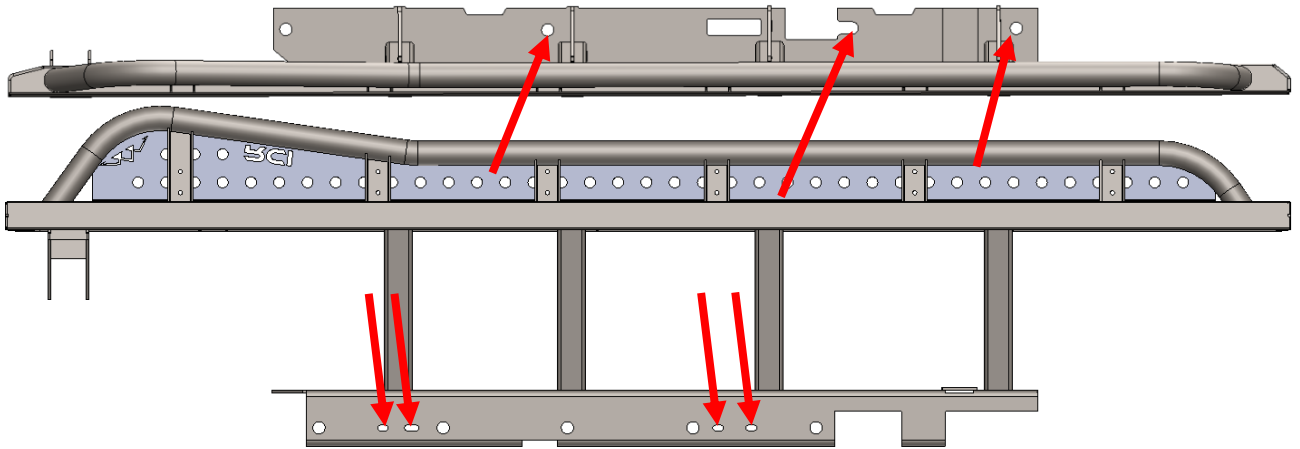

5. With the holes aligned, install four (4) M8 bolts with four(4) 5/16 washers in the four mounting locations on the bottom of the slider frame plate.

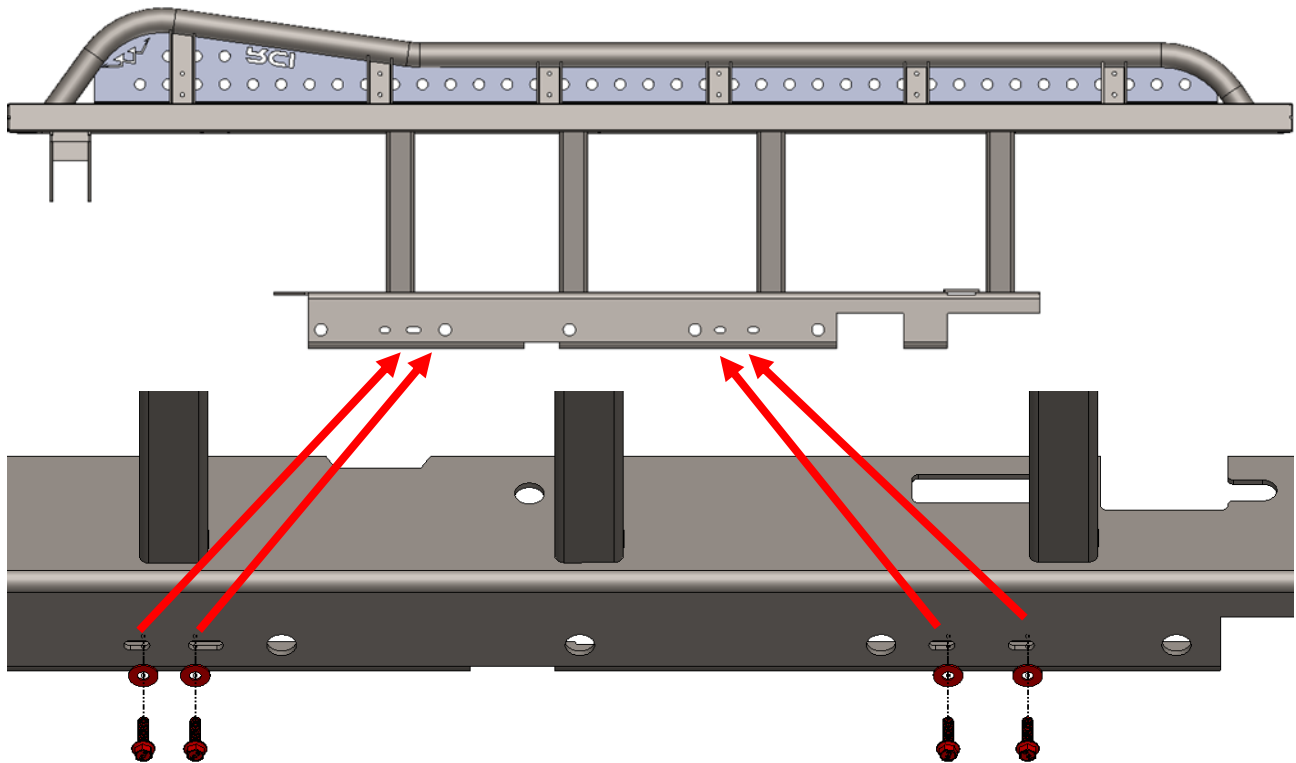

6. Collect the listed hardware and create the following assemblies:

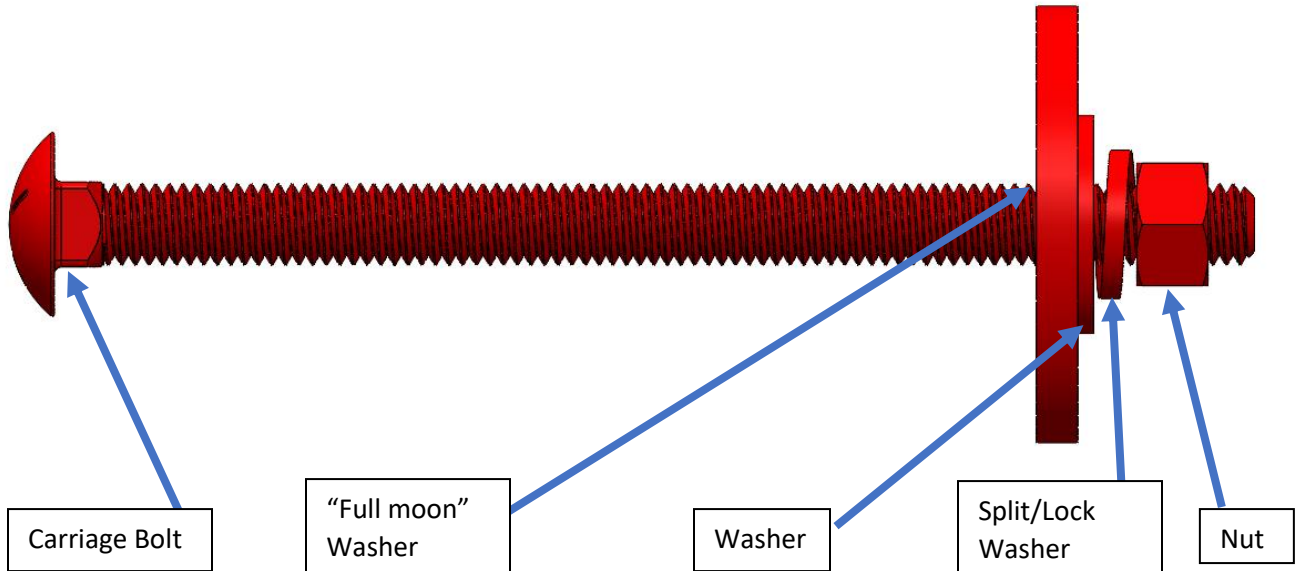

- a. Collect two(2) of each:
 - i. 5/16" x 5.5" carriage bolt
 - ii. 5/16" flat washer
 - iii. 5/16" split lock washer
 - iv. 5/16" nut
 - v. 3/8" x 5.5" carriage bolt
 - vi. 3/8" flat washer
 - vii. 3/8" split lock washer
 - viii. 3/8" nut
- b. Collect six (6) of each:
 - i. "Full Moon" washer

7. Collect the following hardware but do not assemble:

- a. Collect one (1) of each:
 - i. 7/16" x 5.5" carriage bolt
 - ii. 7/16" flat washer
 - iii. 7/16" split lock washer
 - iv. 7/16" nut
 - v. 7/16" carriage bolt plate

8. Feed the carriage bolt assemblies through the large holes at the top of the frame plate with the head of the bolt facing towards the center of the vehicle.
 - a. If needed, adjust the hex nut so that the carriage bolt head is visibly protruding from the inner surface of the vehicle frame.

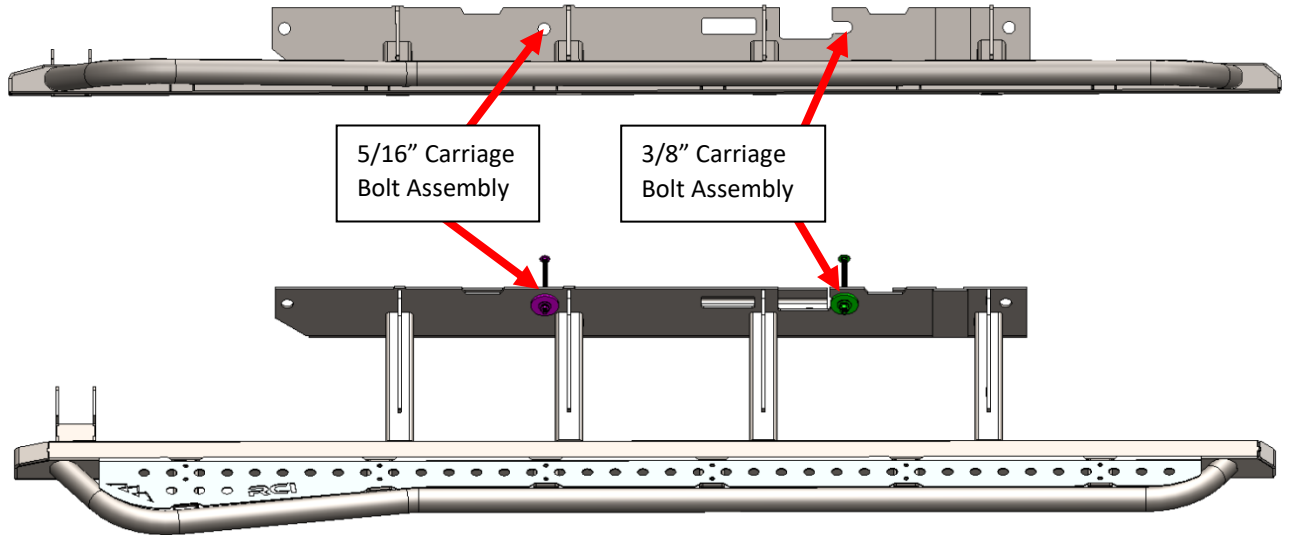

9. Collect a 3/8" carriage bolt plate and hook it over the protruding square head of the 3/8" carriage bolt. These plates will secure the carriage bolts when tightening the nut to secure the slider frame plate. Hand tighten the 3/8" hex nut until the carriage bolt plate is snug against the frame.

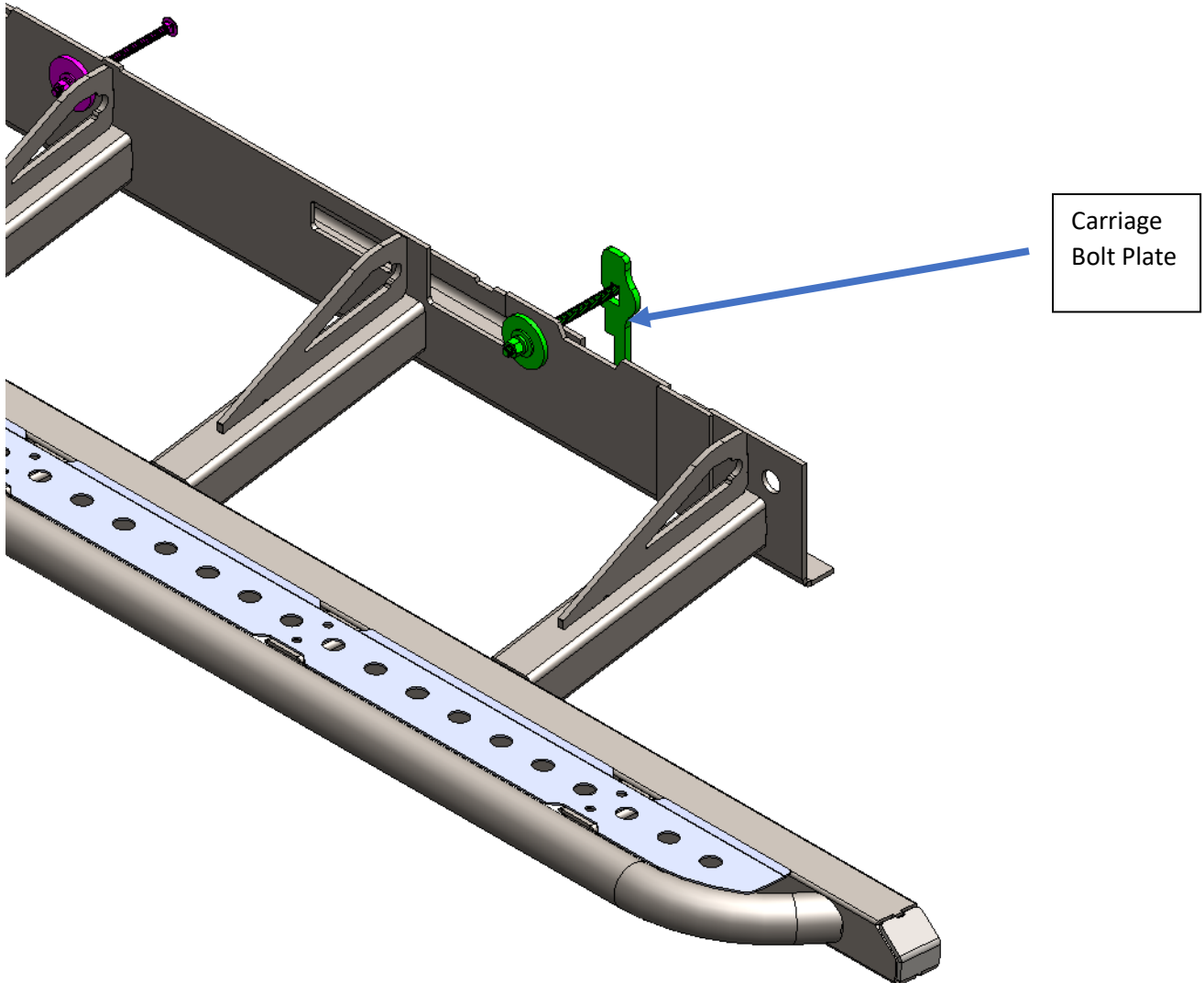

- a. See page 2 to verify hardware order. Detail A1.
10. Repeat step 9 with the 5/16" carriage bolt plate and hardware.
 - a. This process takes some trial and error as the head of the 5/16" carriage bolts are covered by the vehicle crossmembers. Begin by inserting the carriage bolt plates up towards the vehicle body and into vehicle crossmember. When the slot of the carriage bolt plate is aligned with the head of the carriage bolt, move/tilt the plate towards the bolt, hooking the plate on the carriage bolt. The carriage bolt plate/hardware is not easily visible in this step, requiring the process to be carried out nearly entirely by feel. It will likely take a couple of tries to get the plate hooked properly. Practice patience and ensure that the plate is properly installed; it'll be worth it!
 - b. See page 2 to verify hardware order. Detail B1.

11. From the inside of the vehicle frame between the fuel tank and transfer case, insert a 7/16" x 5.5" carriage bolt through the frame and slider frame plate. Hook the 7/16" carriage bolt plate on the head of the carriage bolt before installing the remaining 7/16" hardware.

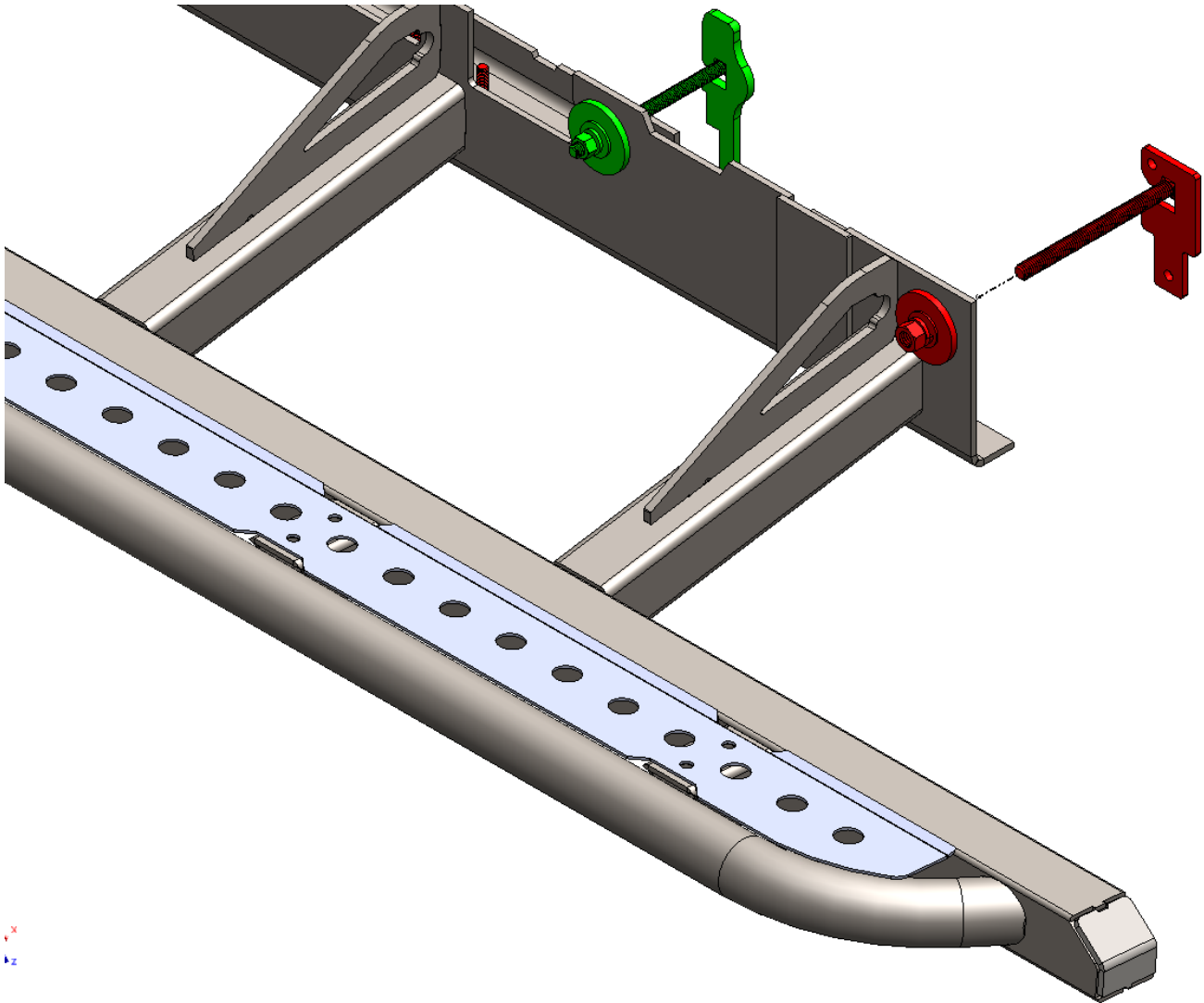

- a. This step uses the 7/16" hardware collected in step 7.
- b. See page 2 to verify hardware order. Detail A2.

12. Secure the rear bolt-on leg to the slider.

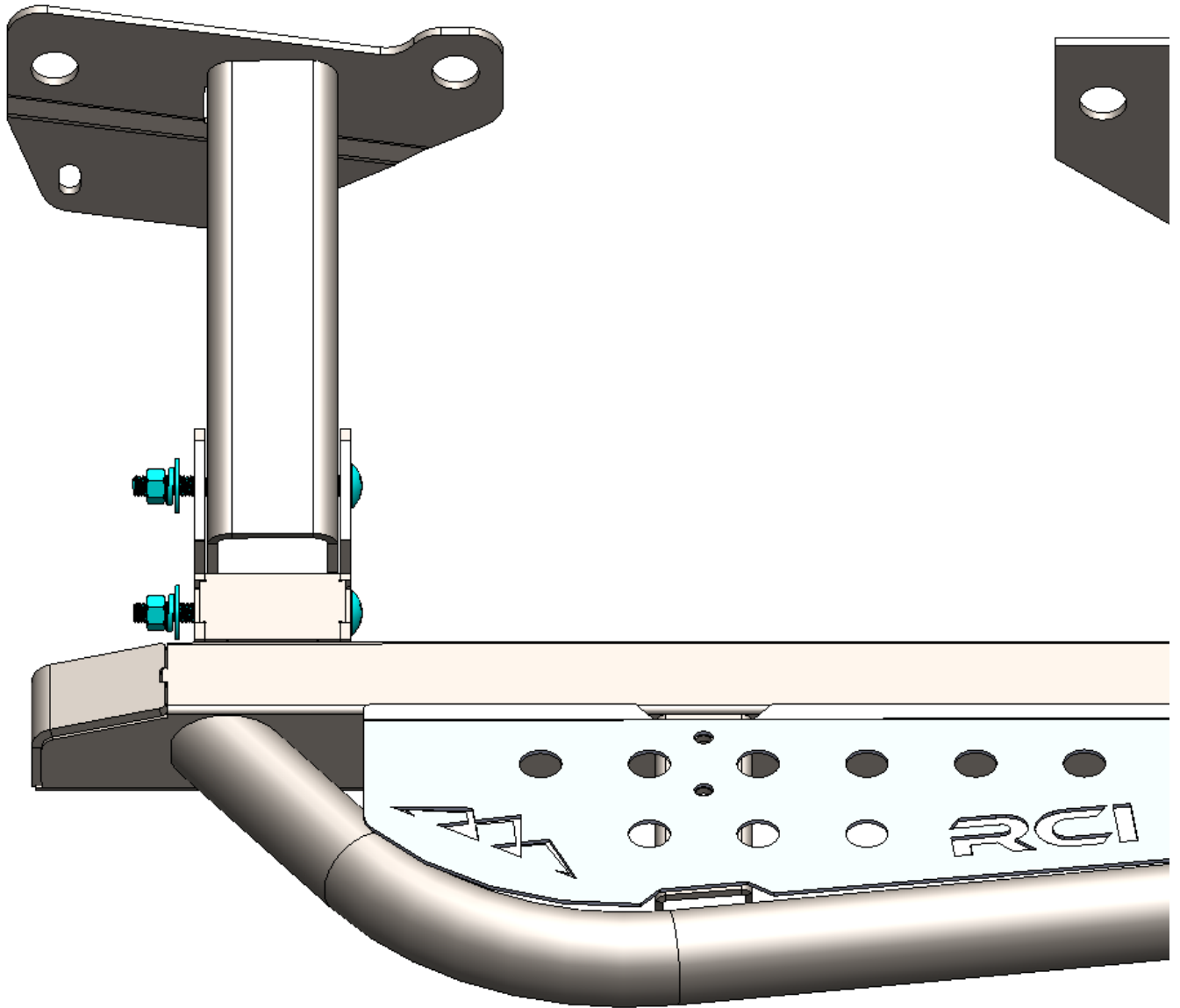

- a. Use two of each of the following hardware:
 - i. 3/8" x 4" carriage bolt
 - ii. 3/8" flat washer
 - iii. 3/8" split lock washer
 - iv. 3/8" nut
- b. Don't tighten the hardware yet.
- c. Refer to page 2 to verify hardware order. Detail B2

13. Align the rear leg frame plate with the vehicle frame and secure it using the remaining 5/16" and 3/8" carriage bolt assemblies created in step 7. The 5/16" carriage bolt assembly will be installed in the upper rear hole of the rear leg frame plate.

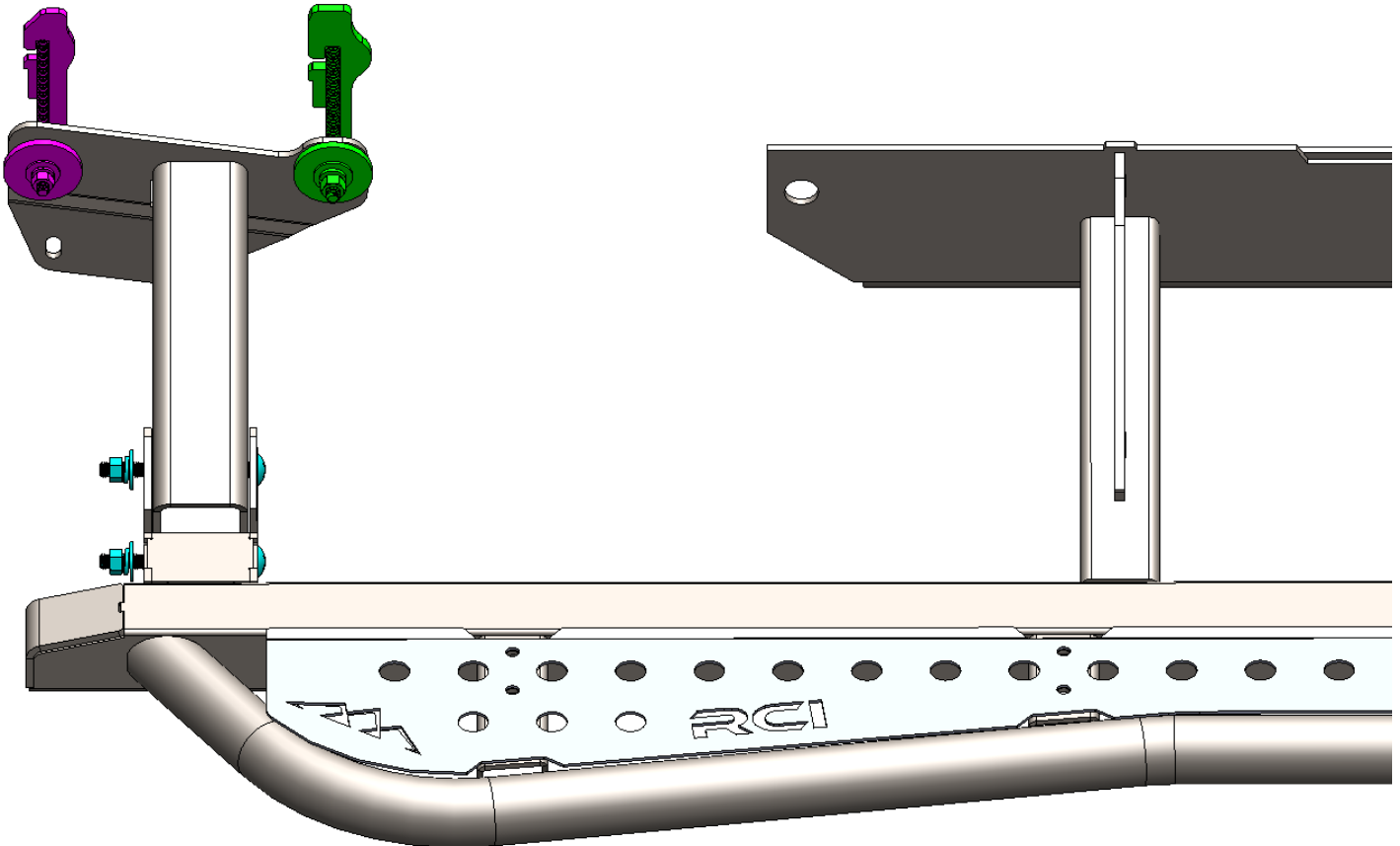

- a. Refer to page 2 to verify hardware order. Detail B1 and A1.
14. Finish securing the rear leg frame plate using one (1) of the included M10 bolt, 3/8" washer, and "MP2" mounting plate. The mounting plate will need to be inserted within the lower linkage mount and held while tightening the M10 bolt.

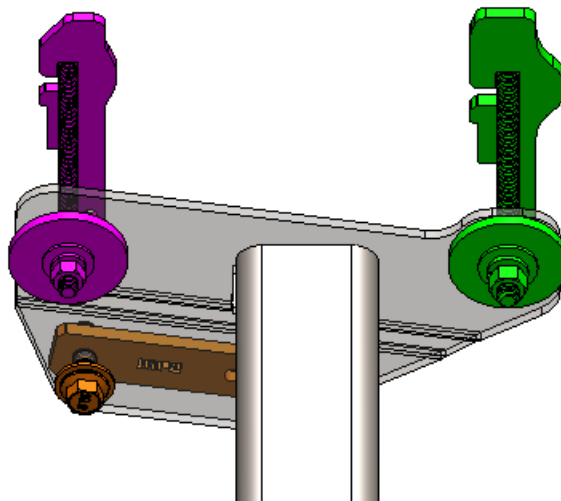

15. Reinstall the vehicle wire harness and grounding wire from step 2a.

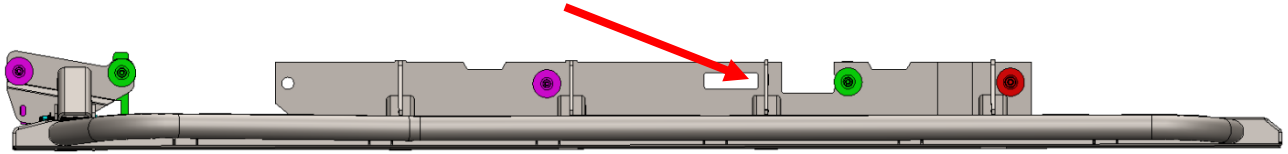

- a. Reinstall the grounding wire using the factory hardware.
 - i. It is recommended at this point to clip the zipties securing the grounding wire to the frame and resecure the wire to the frame in a position that relieves the tension caused by the slider leg gusset.

16. Tighten passenger slider hardware.

- a. Torque the 7/16" carriage bolts to 20 lb-ft.
- b. Torque the 3/8" carriage bolts to 20 lb-ft.
- c. Torque the 5/16" carriage bolts to 12 lb-ft.
- d. Torque the M8 bolts to 19 lb-ft.

17. Congrats, the passenger-side slider is now fully secured to the vehicle! Feel free to continue to the next page to start the driver-side install; Or, take a moment to appreciate your success before continuing on.

18. Tie the included sections of string and wire to the outermost holes of the M8 bolt plates.

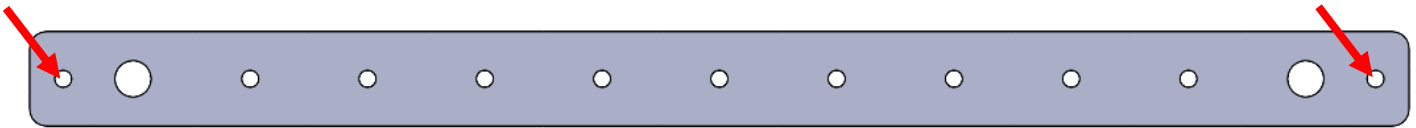

19. Tie an included section of string to this hole of the M8 bolt plate.

- a. This section of string will be used to retrieve the bolt plate from inside the vehicle frame if the slider is ever uninstalled.

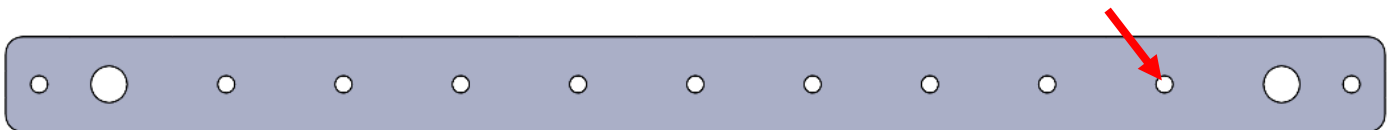

20. Carefully feed the ends of the wire through the holes in the inner driver side of the vehicle frame.

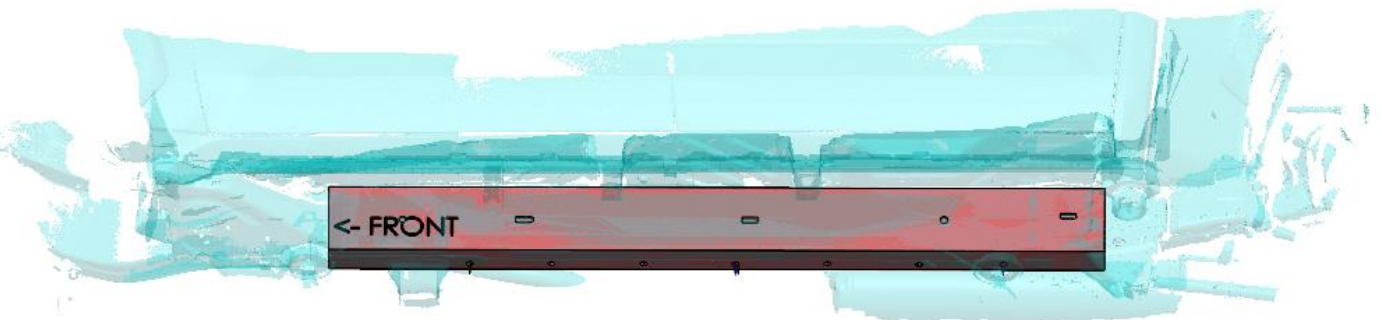
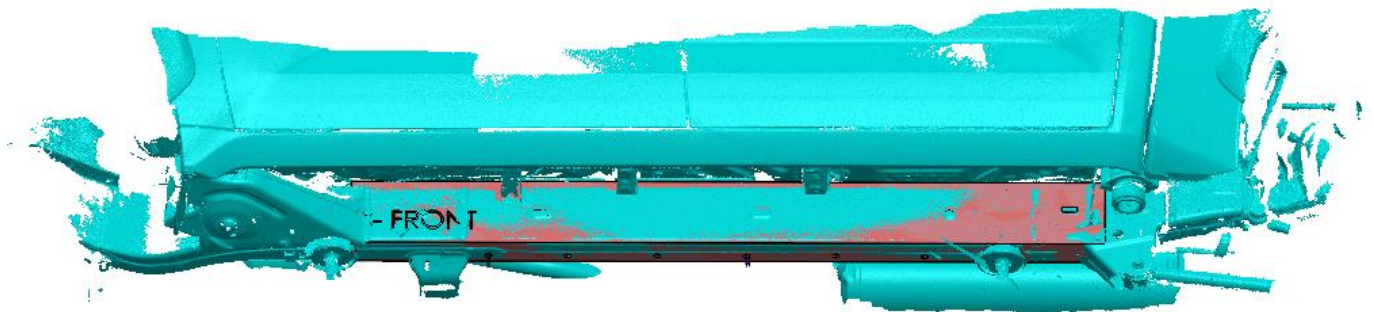

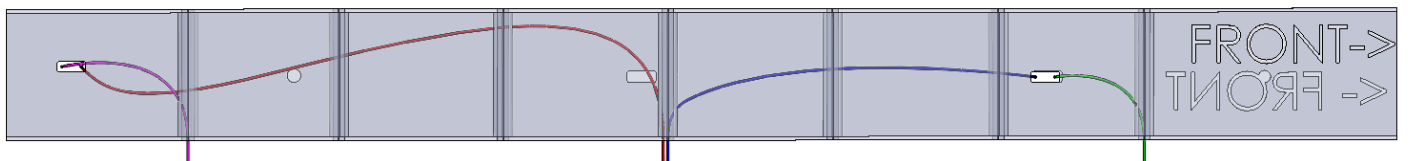
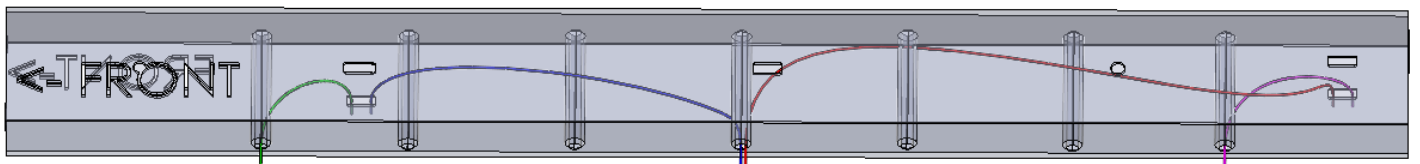
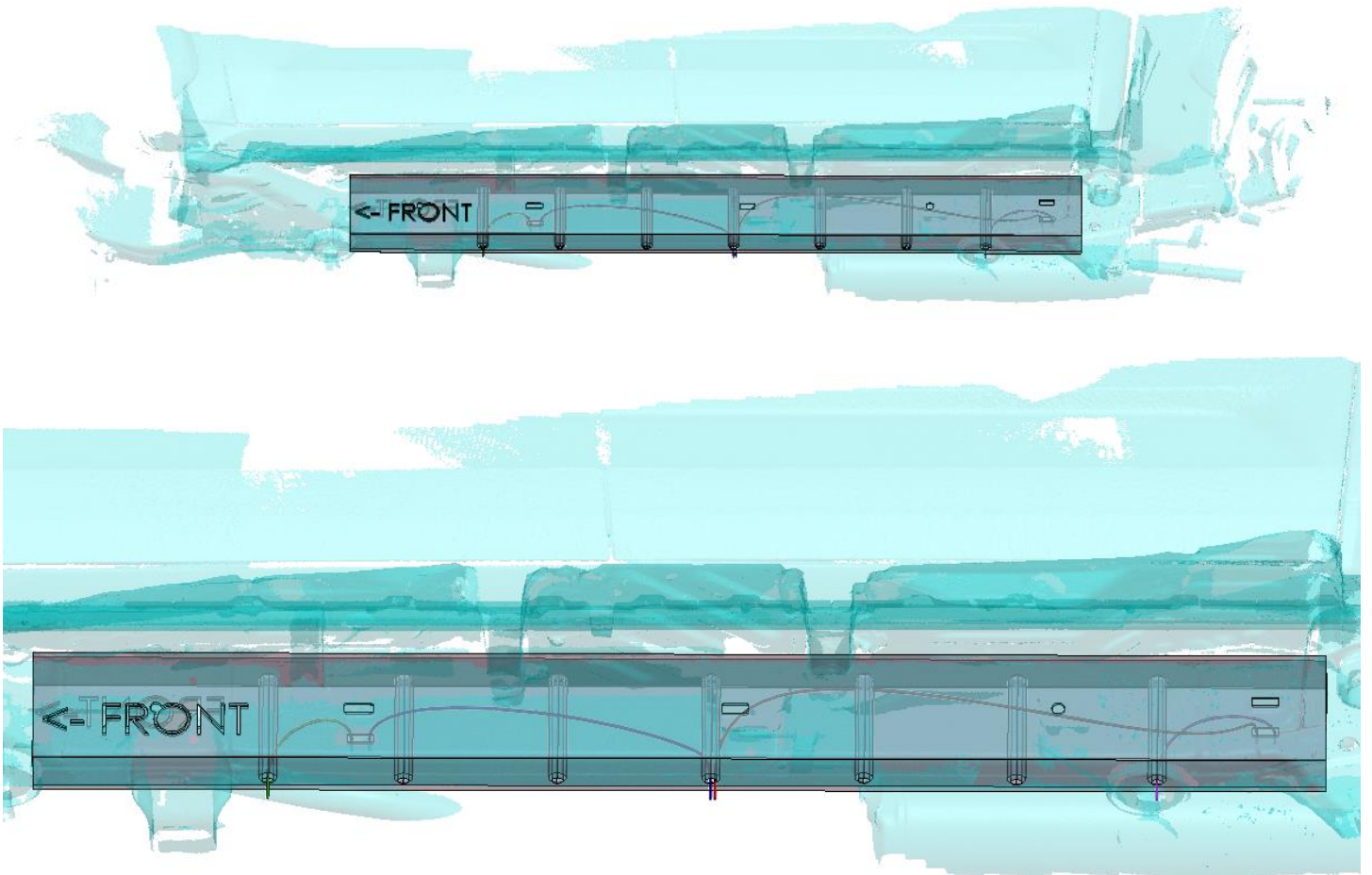

- a. Strings 1 and 2 of threaded plate 1 as viewed from the inside of the vehicle looking out.

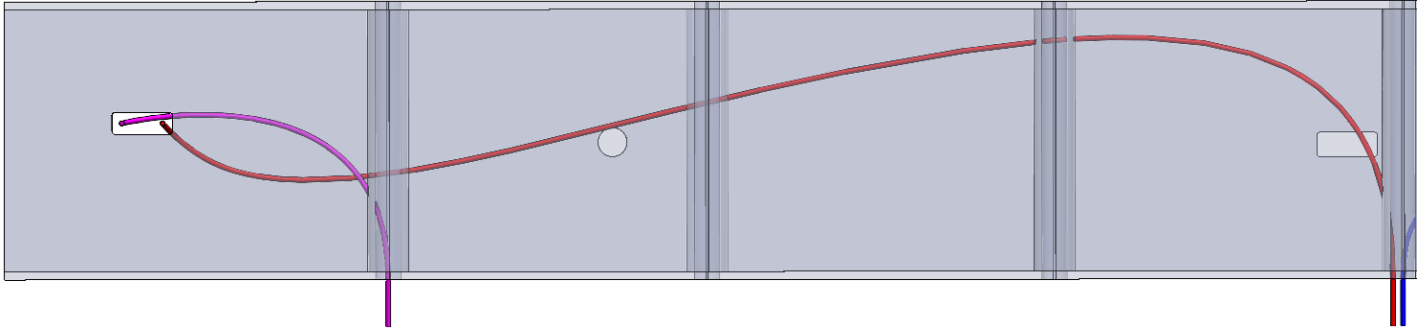

- b. Strings 1 and 2 of threaded plate 2 as viewed from the inside of the vehicle looking out.

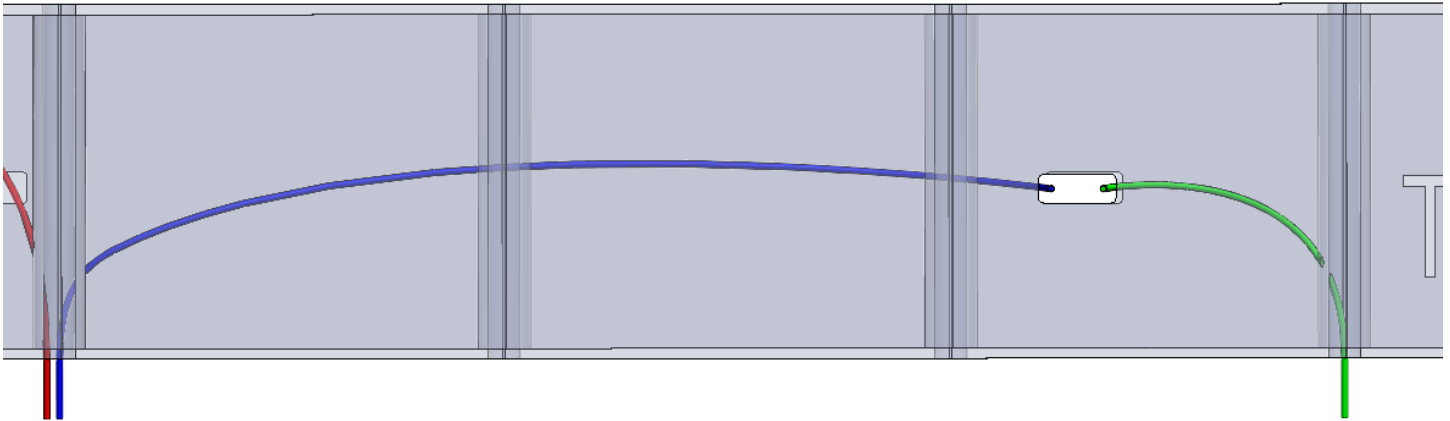

21. Feed the bolt plates through these holes in the driver side of the vehicle frame.

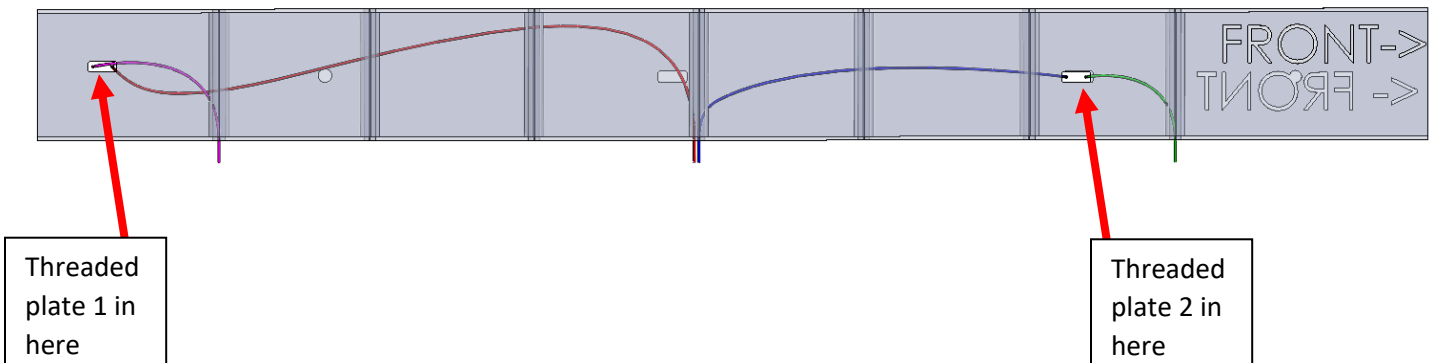

22. Secure the end of the string from step 19 to the driver side of the vehicle frame with tape above the holes in the frame from step 21.
 - a. You may also elect to tie the string to the frame or other point on the vehicle. The critical component of this step is for the string to be accessible. This string will be used to remove the bolt plates from the frame if the slider is ever removed.
23. Use the attached strings to align the threaded holes in the bolt plates with the holes in the lower face of the vehicle frame.

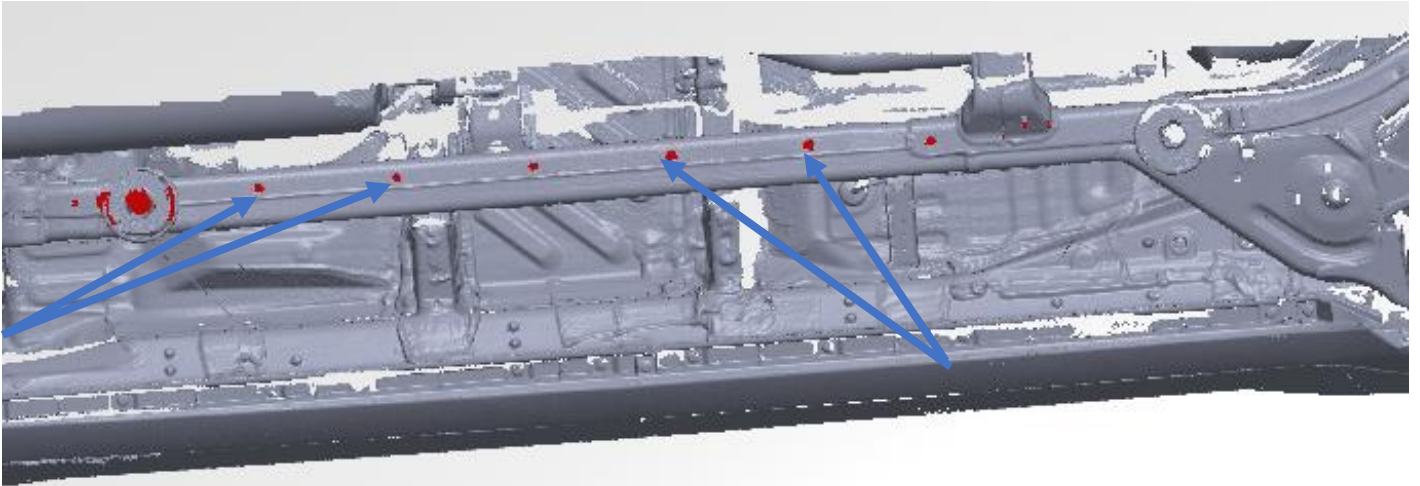

- a. The bolts will align with these corresponding holes on the lower face of the driver slider:

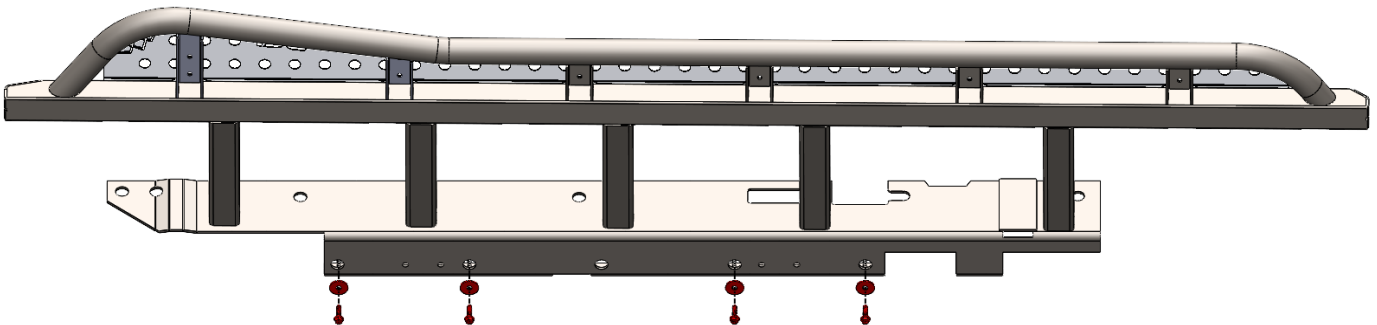

24. With the bolt plates aligned, thread four (4) m8x30mm bolts into the holes of the bolt plates. This will keep the bolt plates from becoming lost in the frame while installing the slider on the vehicle.
25. Identify the driver side slider and lift it up to the frame on the driver side of the vehicle.
 - a. Use of a floor jack or similar equipment will make this process significantly easier.
 - b. The m8 bolts from step 24 will have enough clearance to fit within the holes in the lower face of the slider. Take your time and lift the slider up while feeding the bolts through the slider frame plate.

26. With the slider up on the vehicle frame and the mounting holes aligned, carefully remove one of the bolts from the bolt plate and reinstall with one (1) of the included 5/16" x 1.25" flat washers. Repeat this process until all the lower m8 bolts have been reinstalled with washers.

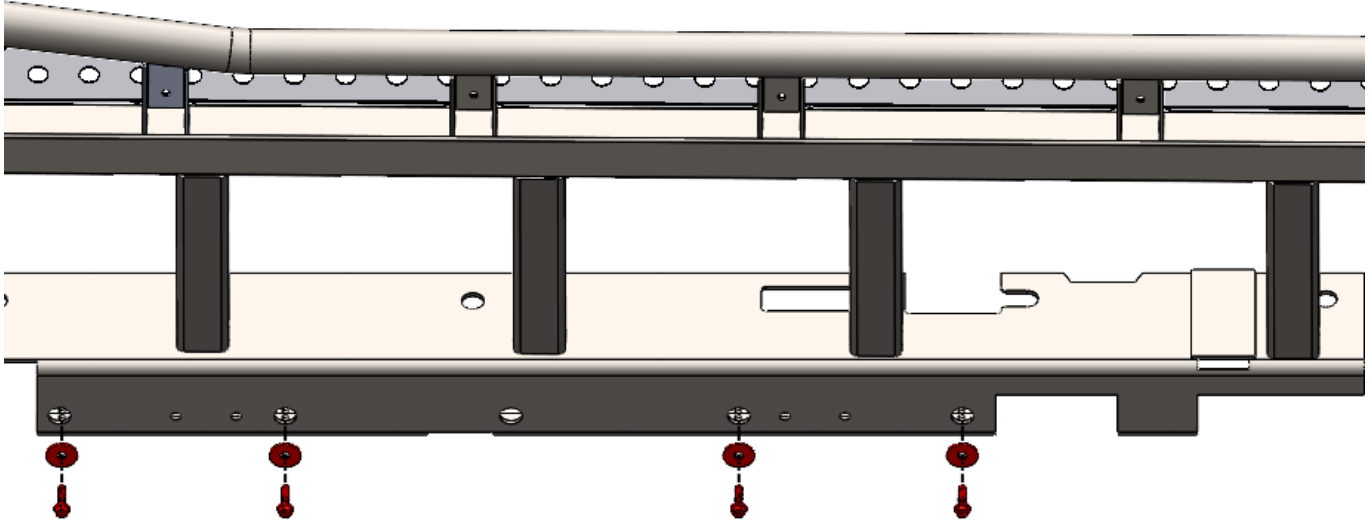

27. Collect the listed hardware and create the following assemblies:

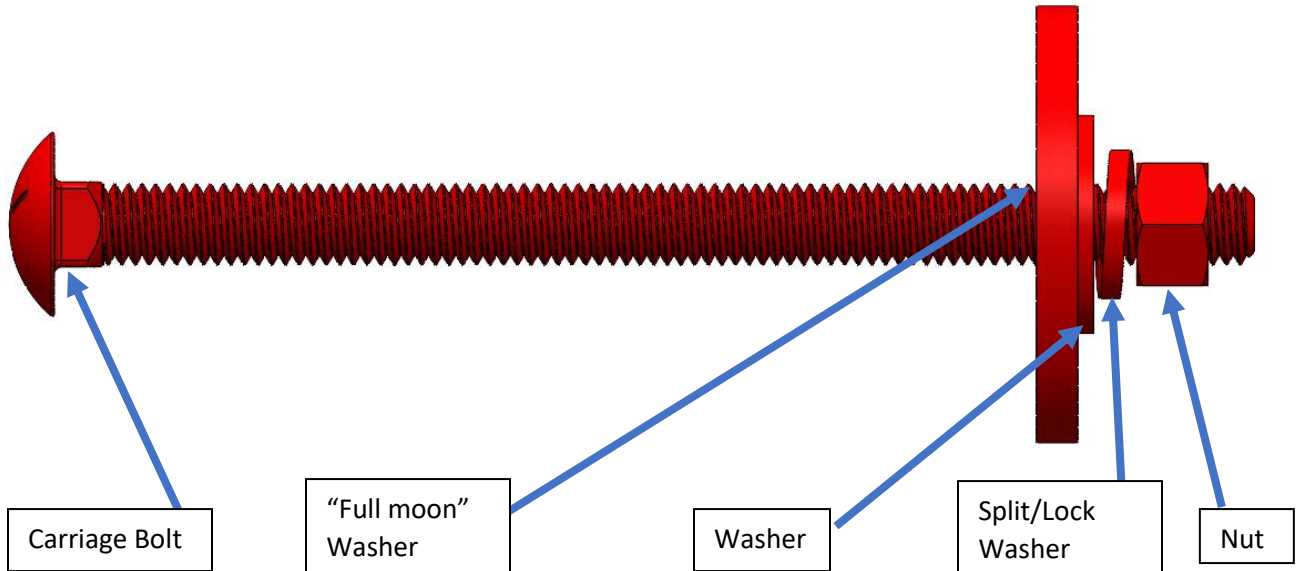

- a. Collect one (1) of each:
 - i. 5/16" x 5.5" carriage bolt
 - ii. 5/16" flat washer
 - iii. 5/16" split lock washer
 - iv. 5/16" nut
- b. Collect five (5) of each:
 - i. "Full Moon" washer

28. Collect the following hardware but do not assemble:

- a. Collect four (4) of each:
 - ii. 7/16" x 5.5" carriage bolt
 - iii. 7/16" flat washer
 - iv. 7/16" split lock washer
 - v. 7/16" nut
 - vi. 7/16" carriage bolt plate

29. Feed the carriage bolt assembly created in step 27 through the large holes at the top of the frame plate with the head of the bolt facing towards the center of the vehicle.
- c. If needed, adjust the hex nut so that the carriage bolt head is visibly protruding from the inner surface of the vehicle frame.

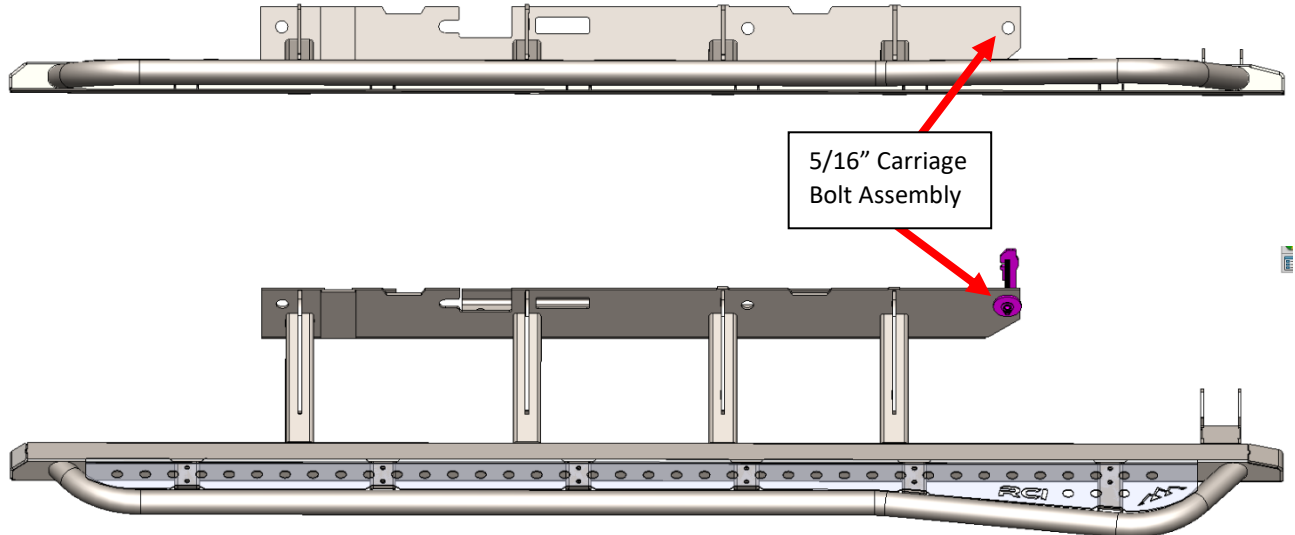

2. Collect a 5/16" carriage bolt plate and hook it over the protruding square head of the 5/16" carriage bolt. These plates will secure the carriage bolts when tightening the nut to secure the slider frame plate. Hand tighten the 5/16" hex nut until the carriage bolt plate is snug against the frame.
 - a. This process takes some trial and error as the head of the 5/16" carriage bolts are covered by the vehicle crossmembers. Begin by inserting the carriage bolt plates up towards the vehicle body and into vehicle crossmember. When the slot of the carriage bolt plate is aligned with the head of the carriage bolt, move/tilt the plate towards the bolt, hooking the plate on the carriage bolt. The carriage bolt plate/hardware is not easily visible in this step, requiring the process to be carried out nearly entirely by feel. It will likely take a couple of tries to get the plate hooked properly. Practice patience and ensure that the plate is properly installed; it'll be worth it!
 - b. See page 2 to verify hardware order. Detail B1.

30. From the inside of the vehicle frame, insert a 7/16" x 5.5" carriage bolt through the frame and slider frame plate in each of these locations. Hook the 7/16" carriage bolt plate on each of the heads of the carriage bolt before installing the remaining 7/16" hardware.

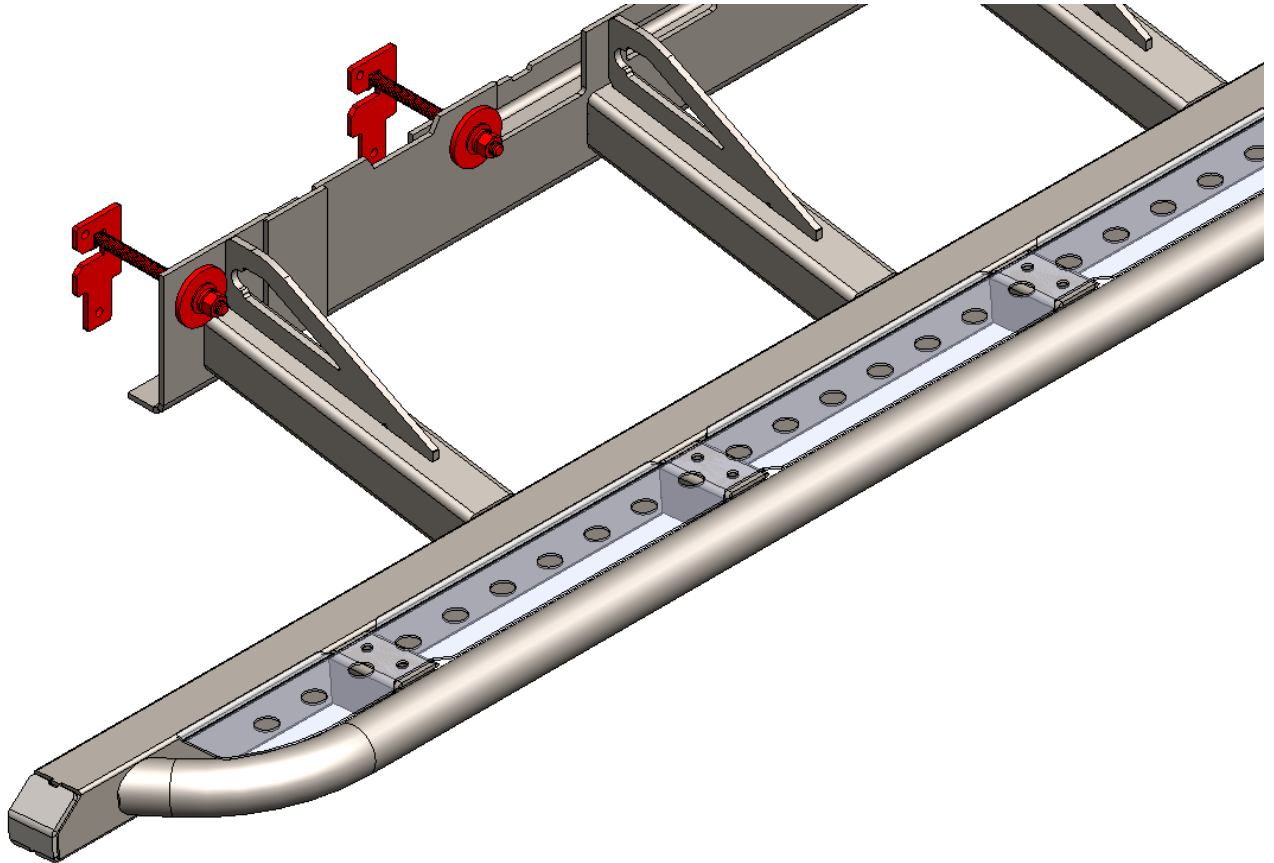

- c. This step uses the 7/16" hardware collected in step 28.
- d. See page 2 to verify hardware order. Detail A2.

31. Secure the rear bolt-on leg to the slider.

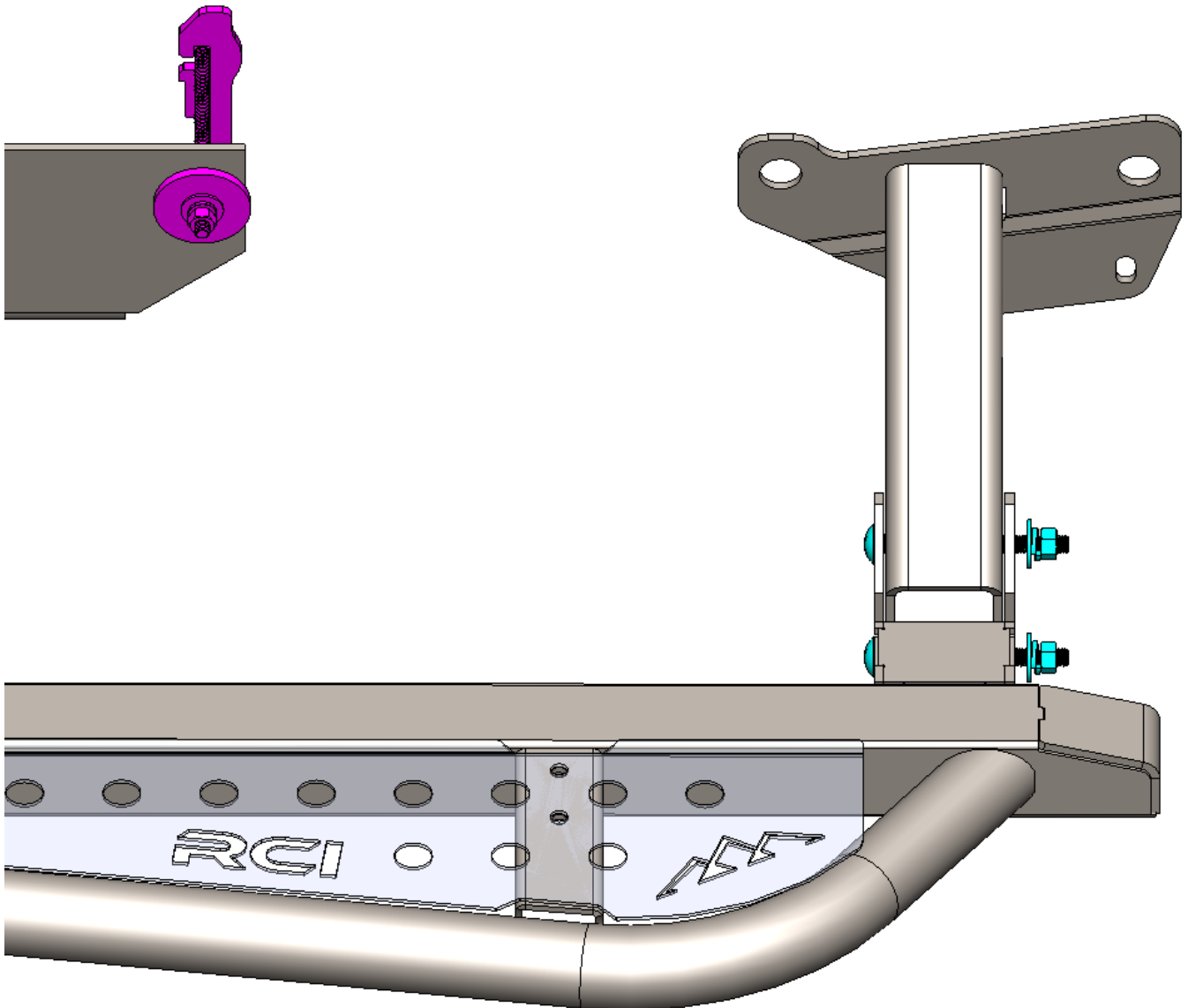

- e. Use two of each of the following hardware:
 - i. 3/8" x 4" carriage bolt
 - ii. 3/8" flat washer
 - iii. 3/8" split lock washer
 - iv. 3/8" nut
- f. Don't tighten the hardware yet.
- g. Refer to page 2 to verify hardware order. Detail B2

32. Align the rear leg frame plate with the vehicle frame and secure it using the remaining 7/16" hardware collected in step 28.

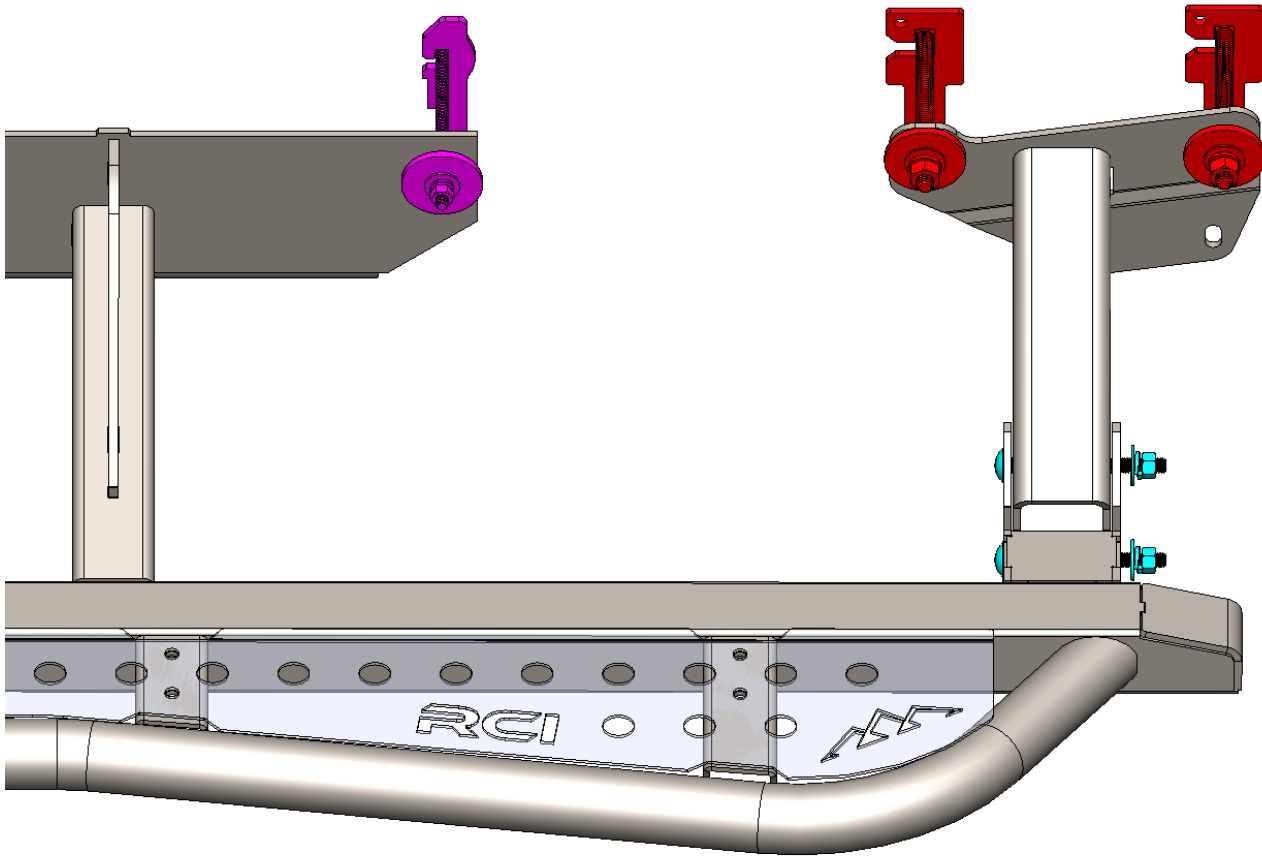

h. Refer to page 2 to verify hardware order. Detail A2.

33. Finish securing the rear leg frame plate using one (1) of each of the included M10 bolt, 3/8" washer, and "MP2" mounting plate. The mounting plate will need to be inserted within the lower linkage mount and held while tightening the M10 bolt.

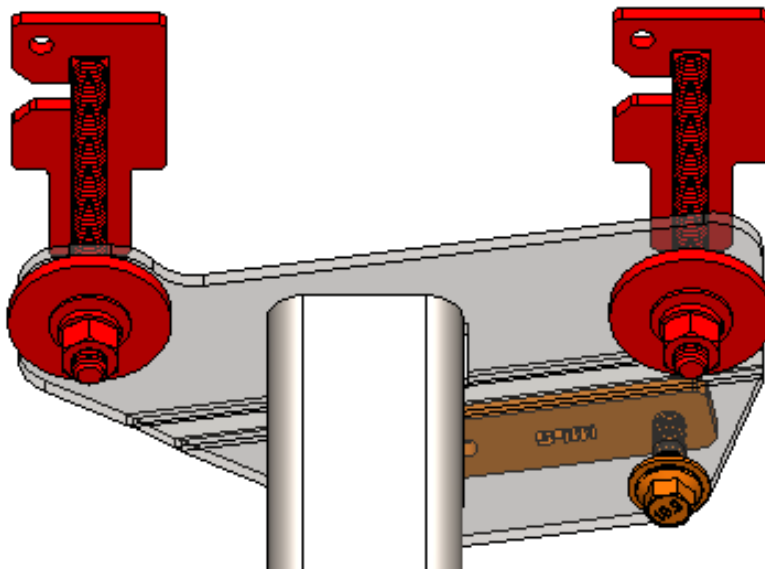



34. Tighten passenger slider hardware.

- i. Torque the 7/16" carriage bolts to 20 lb-ft.
- j. Torque the 3/8" carriage bolts to 20 lb-ft.
- k. Torque the 5/16" carriage bolts to 12 lb-ft.
- l. Torque the M8 bolts to 19 lb-ft.



Enjoy your new RCI protection!



**Share your new install with us on social media!
We love seeing our products out in the wild!**

www.rcimetalworks.com

sales@rcioffroad.com

970-797-3089

REV: 1 | 9/29/2022



Disclaimer: The products sold by RCI Metalworks are intended for off-road use only, should not be modified, and are for use only on the vehicle(s) specifically stated. RCI Metalworks makes no warranties express or implied, including of fitness for a particular purpose or merchantability. RCI Metalworks will not be liable for any damages arising out of the use or misuse of its products. It is the customers' responsibility to ensure the products are safely and properly attached to the vehicle, and all products should be installed by trained professionals. We strive to maintain extremely high-quality standards; however, all RCI Metalworks products are individually handcrafted, may vary slightly, and may contain minor imperfections. Due to the nature of raw aluminum, the material may have minor scratches and other blemishes caused by the manufacturing process, especially on the back side of product. RCI Metalworks is constantly seeking to improve its products and reserves the right to make changes to any product.