

# PRINSU ROOF RACK INSTALLATION GUIDE

---



## TOYOTA TUNDRA DOUBLE CAB

---

All products built and designed by Prinsu Design Studio are intended for off-road use and should be assembled, installed, and used according to Prinsu Design Studio's recommendations. Prinsu Design Studio products should be used safely with good judgment towards others and the environment. By installing Prinsu Design Studio Products on your vehicle you assume all liability. Prinsu Design Studio will not be held liable for damages or loss associated with the installation or use of its products. Be smart, use good judgement, don't overload your vehicle to the point of inferior handling and maneuverability!

# PRINSU ROOF RACK INSTALLATION GUIDE

## CROSSBAR HARDWARE DIAGRAM



PART	DESCRIPTION	QUANTITY
A	1/4"-20 X 1" TORX SCREW	28
B	1/4" SPLIT LOCK WASHER	28
C	1/4" FLAT WASHER	28
	54" CROSS BAR - BLACK 1 X 2	6
	54" CROSS BAR - CLEAR 1 X 2	1

All products built and designed by Prinsu Design Studio are intended for off-road use and should be assembled, installed, and used according to Prinsu Design Studio's recommendations. Prinsu Design Studio products should be used safely with good judgment towards others and the environment. By installing Prinsu Design Studio Products on your vehicle you assume all liability. Prinsu Design Studio will not be held liable for damages or loss associated with the installation or use of its products. Be smart, use good judgement, don't overload your vehicle to the point of inferior handling and maneuverability!

# PRINSU ROOF RACK INSTALLATION GUIDE

## WIND DEFLECTOR HARDWARE DIAGRAM

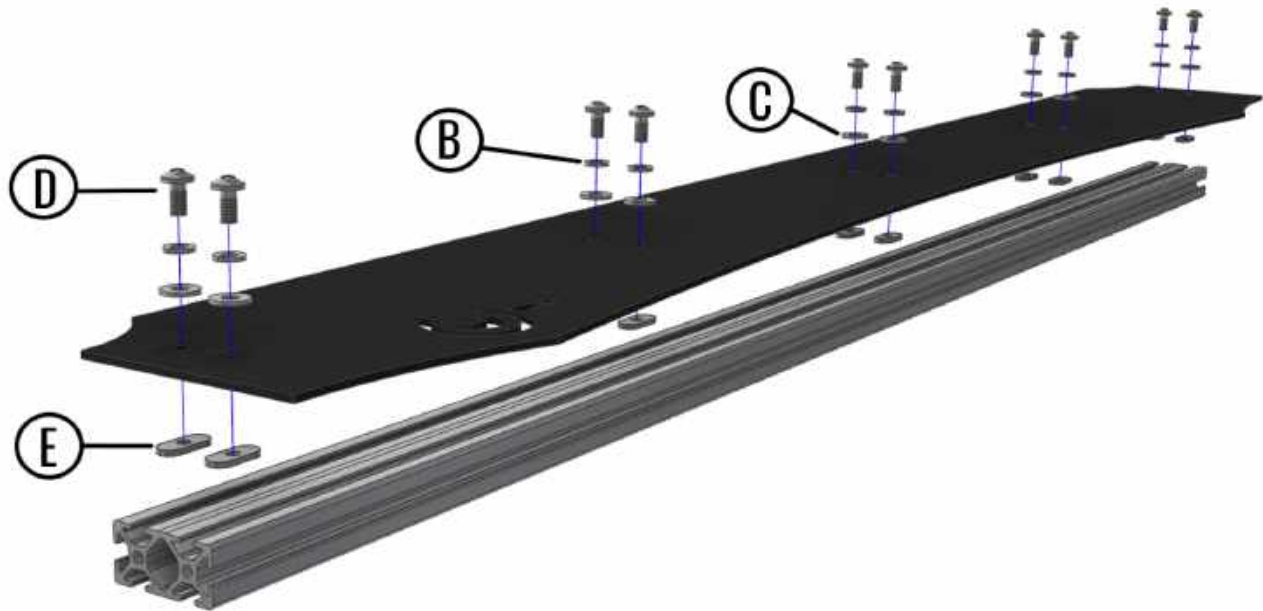

PART	DESCRIPTION	QUANTITY
B	1/4" LOCK WASHER	10
C	1/4" FLAT WASHER	10
D	1/4" - 20 x 1/2" PAN HEAD SCREW	10
E	1/4" - 20, 10 SERIES T-NUT	10

All products built and designed by Prinsu Design Studio are intended for off-road use and should be assembled, installed, and used according to Prinsu Design Studio's recommendations. Prinsu Design Studio products should be used safely with good judgment towards others and the environment. By installing Prinsu Design Studio Products on your vehicle you assume all liability. Prinsu Design Studio will not be held liable for damages or loss associated with the installation or use of its products. Be smart, use good judgement, don't overload your vehicle to the point of inferior handling and maneuverability!

# PRINSU ROOF RACK INSTALLATION GUIDE

## MOUNTING HARDWARE DIAGRAM

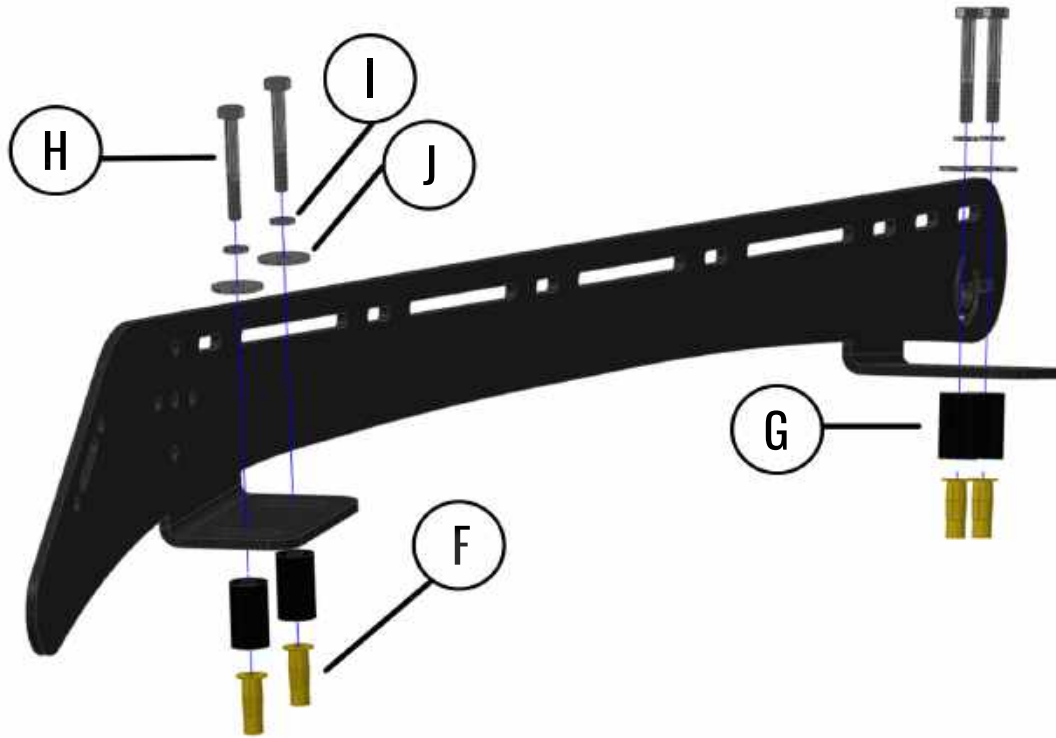

PART	DESCRIPTION	QUANTITY
F	1/4"-20 PLUSNUTS	8
G	1" LONG SPACERS	8
H	STEEL HEX CAP SCREW 1/4" -20 X 2"	8
I	1/4" LOCK WASHER	8
J	STEEL FENDER WASHER 1/4" x 1" O.D.	8
	HEX COUPLER	1
	STEEL HEX CAP SCREW GR5 1/4" -20 X 2" ZINC (FOR HEX COUPLER)	1

All products built and designed by Prinsu Design Studio are intended for off-road use and should be assembled, installed, and used according to Prinsu Design Studio's recommendations. Prinsu Design Studio products should be used safely with good judgment towards others and the environment. By installing Prinsu Design Studio Products on your vehicle you assume all liability. Prinsu Design Studio will not be held liable for damages or loss associated with the installation or use of its products. Be smart, use good judgement, don't overload your vehicle to the point of inferior handling and maneuverability!

# PRINSU ROOF RACK INSTALLATION GUIDE

## WIND DEFLECTOR ATTACHMENT

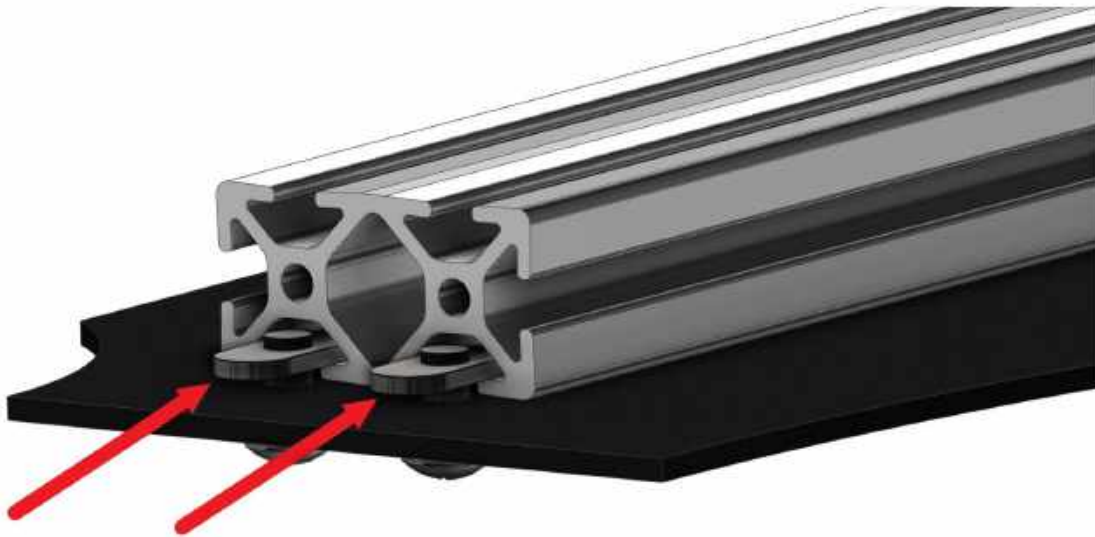

### STEPS

1. INSTALL THE WIND DEFLECTOR HARDWARE AS SHOWN IN THE DIAGRAM ON PAGE 3. THREAD THE SCREWS JUST BARELY INTO THE T-NUTS TO BEGIN WITH.
2. LAY THE WIND DEFLECTOR ON A FLAT SURFACE IN THE ORIENTATION SHOWN ABOVE.
3. FROM ONE END START SLIDING THE EXTRUSION BAR SO THAT THE T-NUTS FEED INTO THE CHANNEL.
4. ONCE EVERYTHING IS LINED UP PROPERLY THEY WILL SLIDE RIGHT TOGETHER.
5. NOW WITH ALL THE T-NUTS FED INTO THE CHANNEL AND THE EXTRUSION BAR AND WIND DEFLECTOR LINED UP FLUSH AT BOTH ENDS, TURN THE ASSEMBLY OVER AND TIGHTEN THE SCREWS UNTIL THE LOCK WASHERS ARE FULLY COMPRESSED.
- 6 . THE WIND DEFLECTOR ASSEMBLY CAN NOW BE BOLTED TO THE ROOF RACK.

All products built and designed by Prinsu Design Studio are intended for off-road use and should be assembled, installed, and used according to Prinsu Design Studio's recommendations. Prinsu Design Studio products should be used safely with good judgment towards others and the environment. By installing Prinsu Design Studio Products on your vehicle you assume all liability. Prinsu Design Studio will not be held liable for damages or loss associated with the installation or use of its products. Be smart, use good judgement, don't overload your vehicle to the point of inferior handling and maneuverability!

# PRINSU ROOF RACK INSTALLATION GUIDE

## ROOF RACK INSTALLATION INSTRUCTIONS

**\*If you do not feel comfortable with the process outlined in this manual please seek professional installation assistance**

**\*Please read all instruction prior to beginning installation. Various steps may relate directly to previous or future parts of the installation process. Prinsu Design Studio is not liable for damages caused to your vehicle during the installation process**

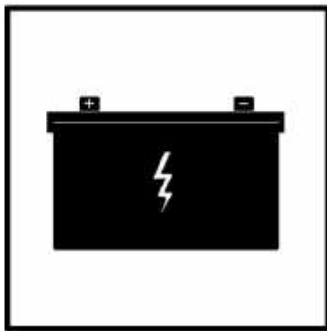

Before beginning any work on the inside of the vehicle first disconnect the battery



Locate and remove the gutter trim on the roof



The trim is held in the front by the tab shown above and pulls up



Measure back from the windshield seem as shown above



Mark at 8.5" on both the passenger and driver side, these will serve as your guide hole locations

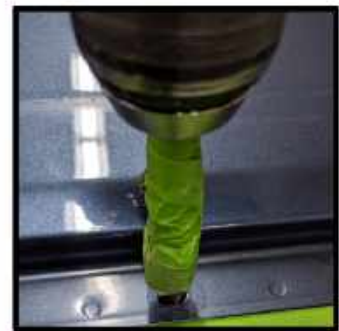

Now drill out the holes to 3/8". Start with a pilot hole and work your way up **\* Using a drillstop is recommended**

All products built and designed by Prinsu Design Studio are intended for off-road use and should be assembled, installed, and used according to Prinsu Design Studio's recommendations. Prinsu Design Studio products should be used safely with good judgment towards others and the environment. By installing Prinsu Design Studio Products on your vehicle you assume all liability. Prinsu Design Studio will not be held liable for damages or loss associated with the installation or use of its products. Be smart, use good judgement, don't overload your vehicle to the point of inferior handling and maneuverability!

## PRINSU ROOF RACK INSTALLATION GUIDE



Next apply silicone to the plusnuts before inserting to insure a water tight seal



Compress the plusnut by using a 1/2" wrench to hold the coupler & tighten with an 7/16" wrench.



Fully installed plusnut



Now assemble the rack, but don't place crossbars over the mounting feet yet. They need to be exposed for upcoming steps



Place the roof rack on the vehicle w/out the spacers and lightly bolt it to the first two installed plusnuts



Ensure that your rack is *squrly* placed on your vehicle, then mark down the location of each slot on the vehicle to drill

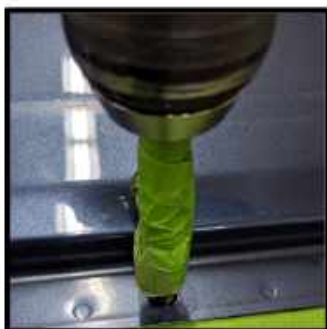

Now remove rack and finish drilling and installing the remaining plusnuts



Pull back the door trim to remove any metal shaving that fall thru while drilling



All products built and designed by Prinsu Design Studio are intended for off-road use and should be assembled, installed, and used according to Prinsu Design Studio's recommendations. Prinsu Design Studio products should be used safely with good judgment towards others and the environment. By installing Prinsu Design Studio Products on your vehicle you assume all liability. Prinsu Design Studio will not be held liable for damages or loss associated with the installation or use of its products. Be smart, use good judgement, don't overload your vehicle to the point of inferior handling and maneuverability!

# PRINSU ROOF RACK INSTALLATION GUIDE



Apply a liberal amount of silicon over the plusnuts and then place the spacers on top to insure a water tight seal



Next cut the gutter trim to sit around the spacers if you desire



Now place the rack back on the roof, once again with out the cross bars over the mounting feet



Tighten down the machine screws bolting the rack to the roof then finally install the crossbars over the mounting feet



The roof rack is now fully installed!



Double check all fasteners to ensure tightness before your first drive



It is recommended to periodically check fastener tightness ...



... This ensures tightness and full functionallity

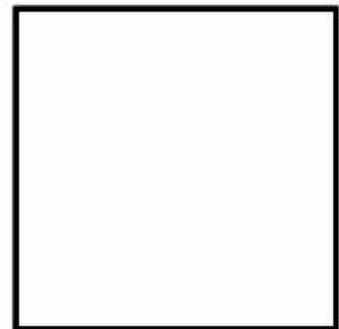

All products built and designed by Prinsu Design Studio are intended for off-road use and should be assembled, installed, and used according to Prinsu Design Studio's recommendations. Prinsu Design Studio products should be used safely with good judgment towards others and the environment. By installing Prinsu Design Studio Products on your vehicle you assume all liability. Prinsu Design Studio will not be held liable for damages or loss associated with the installation or use of its products. Be smart, use good judgement, don't overload your vehicle to the point of inferior handling and maneuverability!



# PRINSU ROOF RACK INSTALLATION GUIDE

---

## WARRANTY

PRINSU DESIGN STUDIO will warranty all PRINSU DESIGN STUDIO manufactured parts for a LIFETIME of use. This limited Lifetime Warranty is effective for as long as the original retail purchaser owns the product. This warranty terminates when the original retail purchaser sells or otherwise transfers the product to any other person. Each manufactured product must be installed following PRINSU DESIGN STUDIO'S recommended fitment and installation procedures. Any customization or modification to the original product design, functionality, or use, either by said customer or by PRINSU DESIGN STUDIO voids all warranty eligibility. It is the sole discretion of CBI Offroad to determine warranty eligibility. Subject to the limitations and exclusions described in this warranty, PRINSU DESIGN STUDIO will remedy defects in materials or workmanship by repairing or replacing, at its option, a defective product without charge for parts. In addition, PRINSU DESIGN STUDIO may elect, at its option, not to repair or replace a defective product but rather issue to a purchaser a refund equal to the purchase price paid for the product or a credit to be used toward the purchase of a new PRINSU DESIGN STUDIO product. No warranty is given for defects caused by normal wear and tear, cosmetic rust scratches, accidents, unlawful vehicle operation, products used for racing or competition, or modification of, or any types of repair of, a PRINSU DESIGN STUDIO manufactured product. The PRINSU DESIGN STUDIO Warranty does not include the powder coated finish. No warranty is given for defects resulting from conditions beyond PRINSU DESIGN STUDIO'S control including, but not limited to, misuse, neglect, overloading, improperly maintained or failure to assemble, mount or use the product in accordance with PRINSU DESIGN STUDIO'S written instructions or guidelines included with the product or implied use made available to the purchaser.

DISCLAIMER OF LIABILITY REPAIR OR REPLACEMENT OF A DEFECTIVE PRODUCT OR THE ISSUANCE OF A REFUND OR CREDIT (AS DETERMINED BY PRINSU DESIGN STUDIO) IS A PURCHASER'S EXCLUSIVE REMEDY UNDER THIS WARRANTY. DAMAGE TO A PURCHASER'S VEHICLE, CARGO AND/OR TO ANY OTHER PERSON OR PROPERTY IS EXCLUDED. THIS WARRANTY IS EXPRESSLY MADE IN LIEU OF ANY AND ALL OTHER WARRANTIES, EXPRESS OR IMPLIED, INCLUDING THE WARRANTIES OF MERCHANTABILITY AND FITNESS FOR A PARTICULAR PURPOSE. PRINSU DESIGN STUDIO'S SOLE LIABILITY TO ANY PURCHASER IS LIMITED TO THE REMEDY SET FORTH ABOVE. IN NO EVENT WILL PRINSU DESIGN STUDIO BE LIABLE FOR ANY LOST PROFITS, LOST SALES, OR FOR ANY CONSEQUENTIAL, DIRECT, INDIRECT, INCIDENTAL, SPECIAL, EXEMPLARY, OR PUNITIVE DAMAGES OR FOR ANY OTHER DAMAGES OF ANY KIND OR NATURE

# PRINSU ROOF RACK INSTALLATION GUIDE



FEATURE	MEASUREMENT/QUANTITY
OVERALL LENGTH	57.5"
SIDE RAIL HEIGHT*	2.5"
HEIGHT ADDED **	1.725
CLEARANCE BETWEEN ROOF AND RACK	.5875
WEIGHT	~43 LBS
54" CROSS BARS - BLACK - (1X2)	6
54" CROSS BAR - CLEAR - (1X2)	1

\*AS MEASURED AT THE CENTER OF THE SIDE RAIL  
 \*\*AS MEASURE FROM THE CENTER POINT OF THE ROOF

All products built and designed by Prinsu Design Studio are intended for off-road use and should be assembled, installed, and used according to Prinsu Design Studio's recommendations. Prinsu Design Studio products should be used safely with good judgment towards others and the environment. By installing Prinsu Design Studio Products on your vehicle you assume all liability. Prinsu Design Studio will not be held liable for damages or loss associated with the installation or use of its products. Be smart, use good judgement, don't overload your vehicle to the point of inferior handling and maneuverability!