

PRINSU LADDER ATTACHMENT INSTALLATION GUIDE



MERCEDES / FRIEGHT LINER SPRINTER VAN

All products built and designed by Prinsu Design Studio are intended for off-road use and should be assembled, installed, and used according to Prinsu Design Studio's recommendations. Prinsu Design Studio products should be used safely with good judgment towards others and the environment. By installing Prinsu Design Studio Products on your vehicle you assume all liability. Prinsu Design Studio will not be held liable for damages or loss associated with the installation or use of its products. Be smart, use good judgement, don't overload your vehicle to the point of inferior handling and maneuverability!

PRINSU LADDER ATTACHMENT INSTALLATION GUIDE

MIDDLE SECTION LADDER RUNG ASSEMBLY SIDE ONE

PARTS

(A) X 14

(B) X 14

(C) X 14

TOOLS NEEDED

7/16" WRENCH

TORX T-30 WRENCH

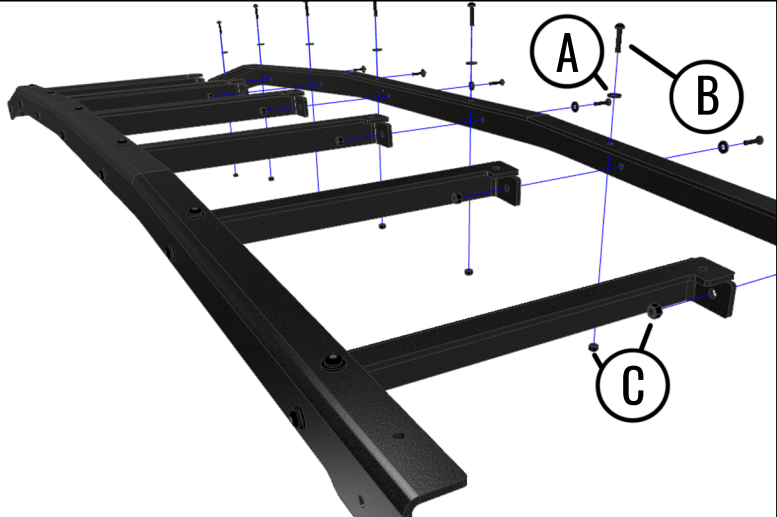

The diagram shows a side view of the ladder rung assembly. It features a main longitudinal rail with several cross-rungs. Three callouts are present: (A) points to a bolt on the top rail, (B) points to a bolt on the side rail, and (C) points to a bolt on the bottom rail. Blue lines connect these callouts to the corresponding parts in the assembly.

MIDDLE SECTION LADDER RUNG ASSEMBLY SIDE TWO

PARTS

(A) X 14

(B) X 14

(C) X 14

TOOLS NEEDED

7/16" WRENCH

TORX T-30 WRENCH

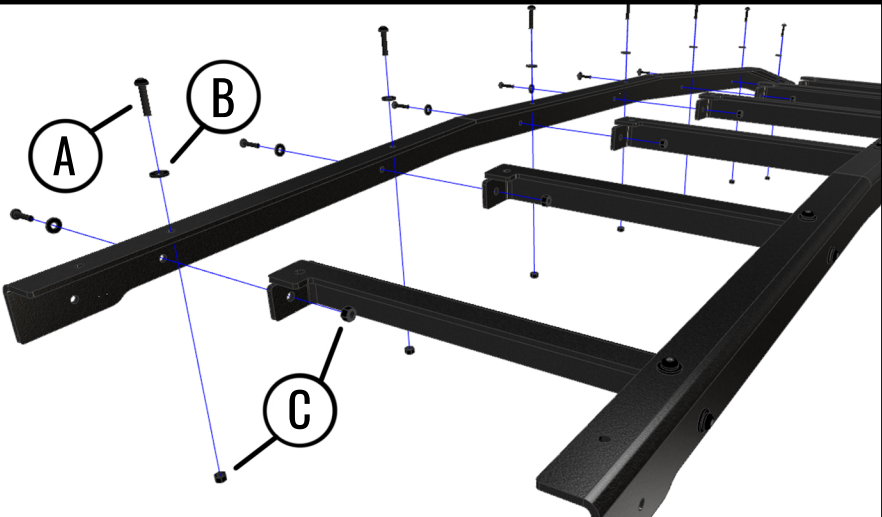

The diagram shows the opposite side of the ladder rung assembly. It features the same main longitudinal rail and cross-rungs. Three callouts are present: (A) points to a bolt on the top rail, (B) points to a bolt on the side rail, and (C) points to a bolt on the bottom rail. Blue lines connect these callouts to the corresponding parts in the assembly.

All products built and designed by Prinsu Design Studio are intended for off-road use and should be assembled, installed, and used according to Prinsu Design Studio's recommendations. Prinsu Design Studio products should be used safely with good judgment towards others and the environment. By installing Prinsu Design Studio Products on your vehicle you assume all liability. Prinsu Design Studio will not be held liable for damages or loss associated with the installation or use of its products. Be smart, use good judgement, don't overload your vehicle to the point of inferior handling and maneuverability!

PRINSU LADDER ATTACHMENT INSTALLATION GUIDE

TOP SECTION TO MIDDLE SECTION ASSEMBLY

PARTS
 (A) X 4
 (B) X 8
 (C) X 2

TOOLS NEEDED
 7/16" WRENCH
 TORX T-30 WRENCH

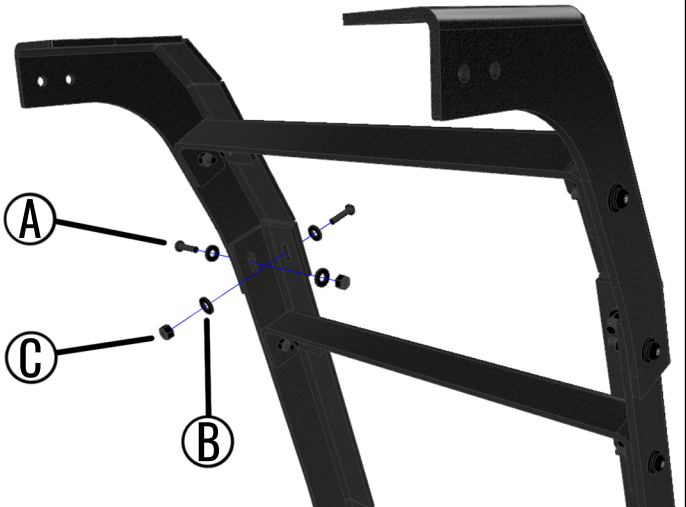

BOTTOM SECTION TO MIDDLE SECTION ASSEMBLY

PARTS
 (A) X 4
 (B) X 8
 (C) X 2

TOOLS NEEDED
 7/16" WRENCH
 TORX T-30 WRENCH

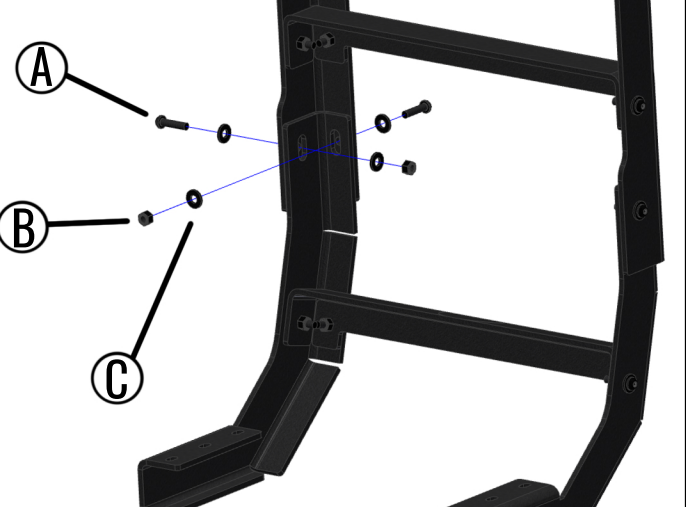

All products built and designed by Prinsu Design Studio are intended for off-road use and should be assembled, installed, and used according to Prinsu Design Studio's recommendations. Prinsu Design Studio products should be used safely with good judgment towards others and the environment. By installing Prinsu Design Studio Products on your vehicle you assume all liability. Prinsu Design Studio will not be held liable for damages or loss associated with the installation or use of its products. Be smart, use good judgement, don't overload your vehicle to the point of inferior handling and maneuverability!

PRINSU LADDER ATTACHMENT INSTALLATION GUIDE

ROOF CONNECTOR BRACKET ASSEMBLY

PARTS

(-) X 3
 (-) X 3
 (-) X 3

TOOLS NEEDED

7/16" WRENCH
 TORX T-30 WRENCH

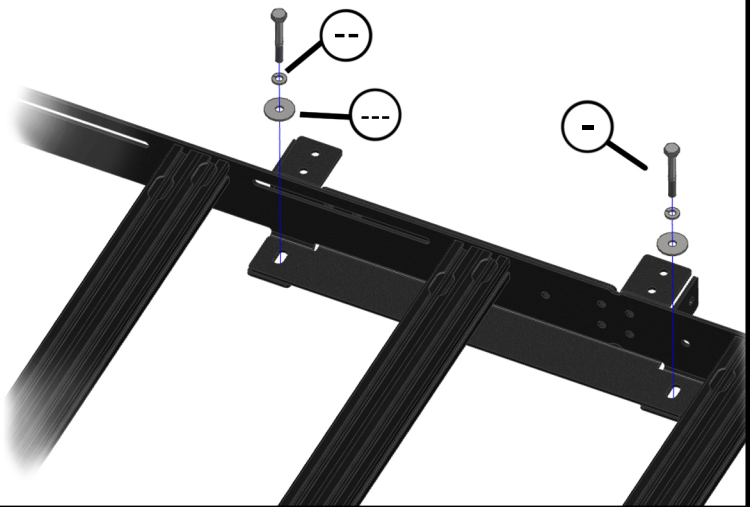

} PARTS FROM ROOF RACK ASSEMBLY

LADDER PLUS SANDWHICH PLATE ASSEMBLY

PARTS

(A) X 9
 (B) X 9
 (C) X 7

TOOLS NEEDED

7/16" WRENCH
 TORX T-30 WRENCH

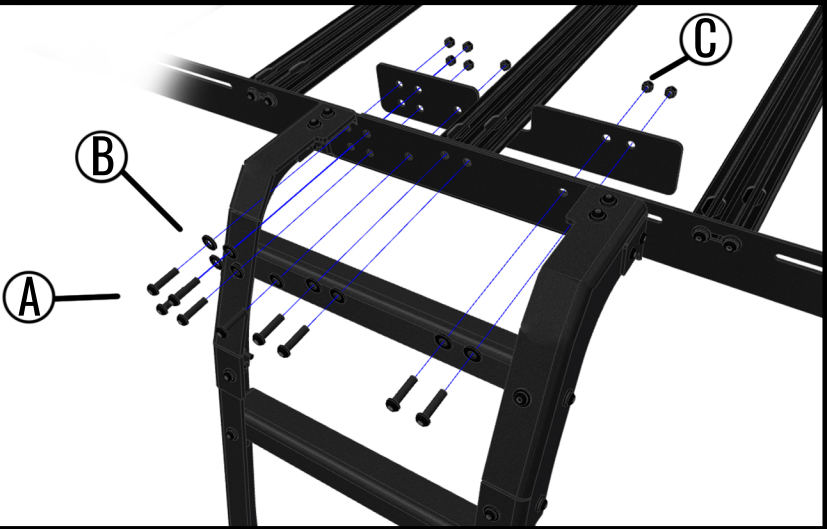

All products built and designed by Prinsu Design Studio are intended for off-road use and should be assembled, installed, and used according to Prinsu Design Studio's recommendations. Prinsu Design Studio products should be used safely with good judgment towards others and the environment. By installing Prinsu Design Studio Products on your vehicle you assume all liability. Prinsu Design Studio will not be held liable for damages or loss associated with the installation or use of its products. Be smart, use good judgement, don't overload your vehicle to the point of inferior handling and maneuverability!

PRINSU LADDER ATTACHMENT INSTALLATION GUIDE

UNDERBODY CONNECTOR BRACKET ASSEMBLY

PARTS

(B) X 6
 (C) X 12
 (D) X 6
 (H) X 2
 (I) X 1
 (J) X 2
 (K) X 1

TOOLS NEEDED

7/16" WRENCH
 9/16" WRENCH

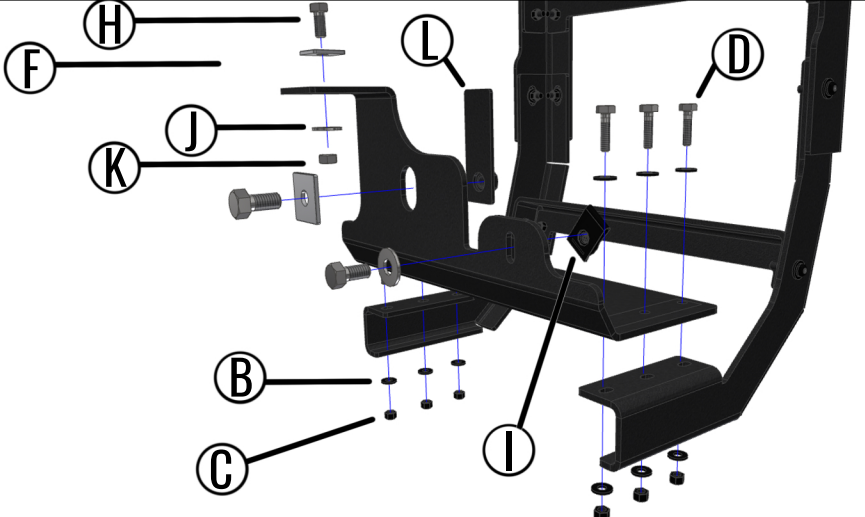

UNDERBODY CONNECTOR BRACKET ASSEMBLY CONTINUED ...

PARTS

(E) X 1
 (G) X 1
 (H) X 1
 (J) X 1

TOOLS NEEDED

9/16" WRENCH
 3/4" WRENCH

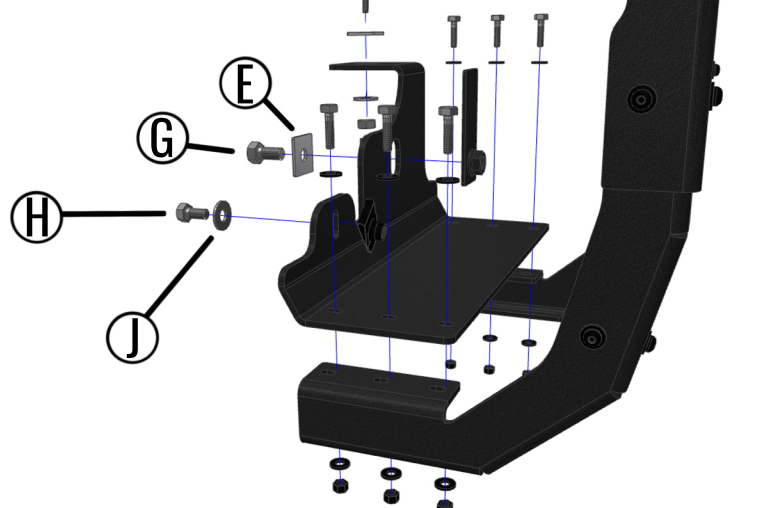

All products built and designed by Prinsu Design Studio are intended for off-road use and should be assembled, installed, and used according to Prinsu Design Studio's recommendations. Prinsu Design Studio products should be used safely with good judgment towards others and the environment. By installing Prinsu Design Studio Products on your vehicle you assume all liability. Prinsu Design Studio will not be held liable for damages or loss associated with the installation or use of its products. Be smart, use good judgement, don't overload your vehicle to the point of inferior handling and maneuverability!

PRINSU LADDER ATTACHMENT INSTALLATION GUIDE

UNDERBODY CONNECTOR BRACKET

STEPS

REMOVE THE LARGE ROUND RUBBER COVER TO THE UPPER ACCESS HOLE AND THE SMALL RUBBER COVER TO THE LOWER ACCESS HOLE

SLIDE IN THE STICK NUT TAB TO ALIGN WITH THE BOTTOM ACCESS HOLE

PUT THE UNDER BODY CONNECTOR BRACKET IN PLACE AND HAND TIGHTEN IT TO THE STICK NUT TAB

NOW MARK THE LOCATION CIRCLED IN RED AND DRILL OUT

TOOLS NEEDED

3/8" DRILL BIT



UNDERBODY CONNECTOR BRACKET CONTINUED ...

STEPS

NEXT MARK THE LOCATION OF THE FORWARD LOWER ACCESS HOLE SLOT

REMOVE THE UNDERBODY CONNECTOR BRACKET AND ALIGN THE CLIP NUT TO SIT OVER THE MARKED AREA

MARK AGAIN IN A DIFFERENT COLOR WHERE THE CLIP NUT RESTS, REMOVE AND DRILL OUT

ASSEMBLY CAN NOW BE FULLY COMPLETED

TOOLS NEEDED

3/8" DRILL BIT



All products built and designed by Prinsu Design Studio are intended for off-road use and should be assembled, installed, and used according to Prinsu Design Studio's recommendations. Prinsu Design Studio products should be used safely with good judgment towards others and the environment. By installing Prinsu Design Studio Products on your vehicle you assume all liability. Prinsu Design Studio will not be held liable for damages or loss associated with the installation or use of its products. Be smart, use good judgement, don't overload your vehicle to the point of inferior handling and maneuverability!

PRINSU ROOF RACK INSTALLATION GUIDE

WARRANTY

PRINSU DESIGN STUDIO will warranty all PRINSU DESIGN STUDIO manufactured parts for a LIFETIME of use. This limited Lifetime Warranty is effective for as long as the original retail purchaser owns the product. This warranty terminates when the original retail purchaser sells or otherwise transfers the product to any other person. Each manufactured product must be installed following PRINSU DESIGN STUDIO'S recommended fitment and installation procedures. Any customization or modification to the original product design, functionality, or use, either by said customer or by PRINSU DESIGN STUDIO voids all warranty eligibility. It is the sole discretion of CBI Offroad to determine warranty eligibility. Subject to the limitations and exclusions described in this warranty, PRINSU DESIGN STUDIO will remedy defects in materials or workmanship by repairing or replacing, at its option, a defective product without charge for parts. In addition, PRINSU DESIGN STUDIO may elect, at its option, not to repair or replace a defective product but rather issue to a purchaser a refund equal to the purchase price paid for the product or a credit to be used toward the purchase of a new PRINSU DESIGN STUDIO product. No warranty is given for defects caused by normal wear and tear, cosmetic rust scratches, accidents, unlawful vehicle operation, products used for racing or competition, or modification of, or any types of repair of, a PRINSU DESIGN STUDIO manufactured product. The PRINSU DESIGN STUDIO Warranty does not include the powder coated finish. No warranty is given for defects resulting from conditions beyond PRINSU DESIGN STUDIO'S control including, but not limited to, misuse, neglect, overloading, improperly maintained or failure to assemble, mount or use the product in accordance with PRINSU DESIGN STUDIO'S written instructions or guidelines included with the product or implied use made available to the purchaser.

DISCLAIMER OF LIABILITY REPAIR OR REPLACEMENT OF A DEFECTIVE PRODUCT OR THE ISSUANCE OF A REFUND OR CREDIT (AS DETERMINED BY PRINSU DESIGN STUDIO) IS A PURCHASER'S EXCLUSIVE REMEDY UNDER THIS WARRANTY. DAMAGE TO A PURCHASER'S VEHICLE, CARGO AND/OR TO ANY OTHER PERSON OR PROPERTY IS EXCLUDED. THIS WARRANTY IS EXPRESSLY MADE IN LIEU OF ANY AND ALL OTHER WARRANTIES, EXPRESS OR IMPLIED, INCLUDING THE WARRANTIES OF MERCHANTABILITY AND FITNESS FOR A PARTICULAR PURPOSE. PRINSU DESIGN STUDIO'S SOLE LIABILITY TO ANY PURCHASER IS LIMITED TO THE REMEDY SET FORTH ABOVE. IN NO EVENT WILL PRINSU DESIGN STUDIO BE LIABLE FOR ANY LOST PROFITS, LOST SALES, OR FOR ANY CONSEQUENTIAL, DIRECT, INDIRECT, INCIDENTAL, SPECIAL, EXEMPLARY, OR PUNITIVE DAMAGES OR FOR ANY OTHER DAMAGES OF ANY KIND OR NATURE