

# Front Bumper Installation Instructions

P/N 210505: 2019+ Mercedes Sprinter Front Bumper

## Before you begin:

- *This product is compatible with the Sprinter 1500, 2500, and 3500*
- *Stainless steel hardware may bind together when tightening — apply an anti-seize assembly lubricant to the threads of each bolt before assembly*
- *This installation requires two or more people*



## Required Tools:

- Standard and metric wrench set
- Standard and metric socket set
- Flat head screwdriver
- Hammer
- Putty knife
- Razor blade or box cutter
- Painter’s masking tape

## Included Hardware:

<b>P/N</b>	<b>Description</b>	<b>Quantity</b>
70124	M8-1.25 x 40mm bolt	8
70101	M8-1.25 Nut	8
70020	5/16" SS washer	8
70111	5/16" split locking washer	16
70036	½"-13 x 1- ½" grade 8 bolt	4
70035	½" washer	8
70033	½"-13 nylon-locking nut	4
70094	¼"-20 x ¾" SS button head bolt	4
70060	¼"-20 x 1" SS button head bolt	4
70009	¼" SS washer	16
70008	¼"-20 nylon-locking nut	8
70246	Antiseize bolt lubricant packet, 2g	1
n/a	Zip ties	2

**Additional Parts:**

***Description***

Air temperature sensor bracket

Steel mounting bracket, driver side

Steel mounting bracket, passenger side

Fairlead cover (*pre-installed*)

Collision assist sensor bracket, driver side

Collision assist sensor bracket, passenger side

Collision assist sensor carriage

Front radar sensor window (*pre-installed*)

Fender Plastic Support Brackets

**Quantity Picture**

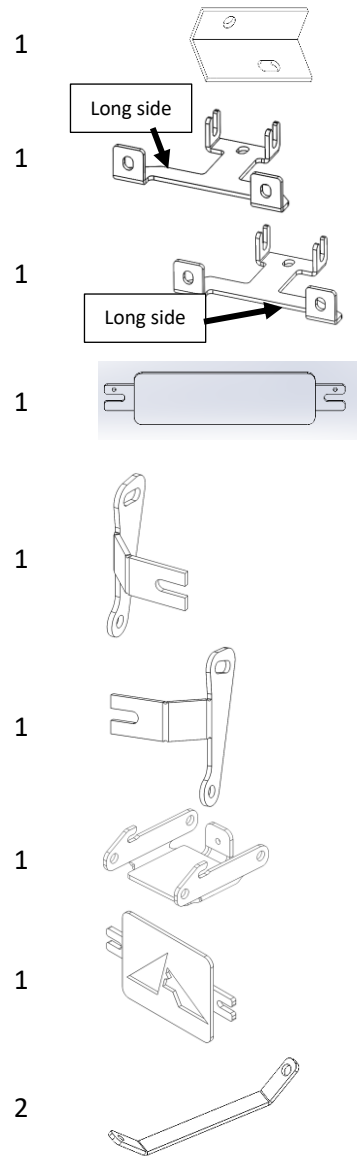

**Stock Bumper Removal:**

1. Open and secure the hood.
2. Remove the three (3) torx screws across the top of the grille; reference Figure 1.



Figure 1: Grille Screws

3. Pull the grille slightly away from the vehicle and unclip the grille in the six (6) indicated locations (see Figure 2 & 3). Once all tabs have been released, the grille can be removed.



Figure 2: Grille Tab Locations



Figure 3: Grille Tab Close Up

4. Remove the torx bolt near the top of the stock bumper on both sides seen with the grille remove. \*Some Sprinter models may have additional hex bolt in recessed hole that will also need to be removed. Reference Figure 4.

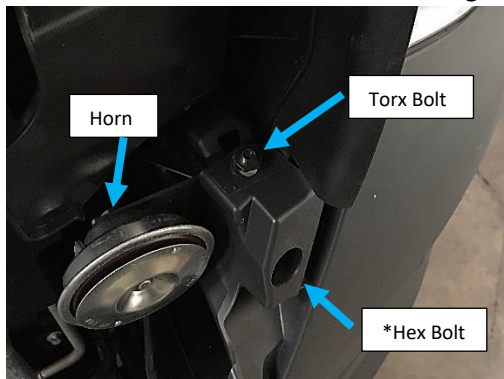

Figure 4: Torx Bolts Near Top of Stock Bumper

5. Remove the two (2) plastic caps on the front bumper step to reveal two (2) torx bolts. Do not yet remove torx bolts (reference Figure 5 & 6).



Figure 5: Plastic Cap Location



Figure 6: Front Bumper Step with Plastic Cap Removed

6. Remove the six (6) plastic rivets on the inside of each fender well. Gently pull the center of the rivet out, then remove entire rivet. Reference Figures 7-9.

*PRO TIP: Access to the rivets is much easier by turning the vehicle's wheels.*



Figure 7: Plastic Rivets on the Inside of the Wheel Well

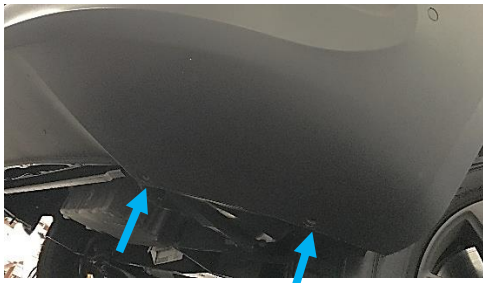

Figure 8: Plastic Rivets on Underside of Bumper



Figure 9: Example of the Plastic Rivet

7. Pull gently on the corner of the plastic bumper directly away from the vehicle. Start in the corner nearest the wheel well working towards the center. Repeat for other side of vehicle. Reference Figure 10.



Figure 10: Removing Plastic Bumper

8. Remove the final two (2) torx bolt holding on the stock bumper on the bumper step as shown in Figure 6.
9. Remove stock front bumper by pulling directly away from vehicle being sure to disconnect any sensors that are attached.
10. Remove the horn (seen in Figure 4).

11. Remove the plastic shrouds on either side of the radiator by depressing the indicated tab and sliding each shroud up. Repeat for both driver and passenger sides. Reference Figure 11.

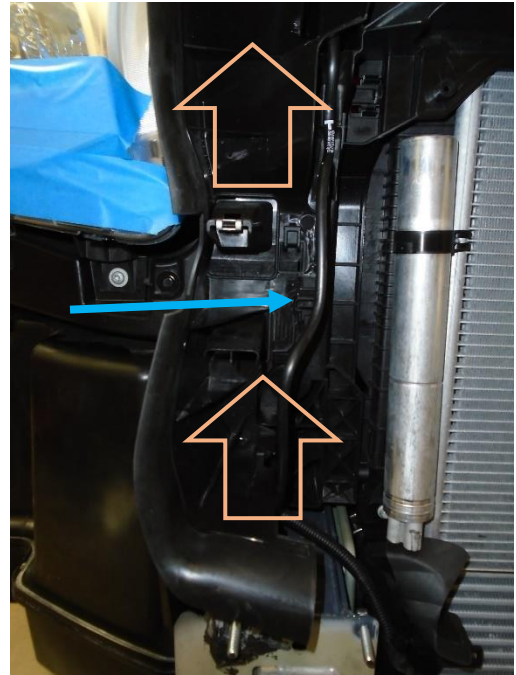

Figure 11: Plastic Shroud Removal

12. Remove the collision prevention sensor plastic bracket by unscrewing the two (2) torx bolts near the top of the radiator.
13. Remove the sensor from the plastic bracket.
14. Remove the eight (8) bolts holding the stock steel bumper in place using a 13mm wrench as shown in Figure 12. CAUTION: Once all the bolts are removed, the bumper may fall if not properly supported.



Figure 12: Four (4) of the Frame Bolts Holding the Stock Steel Bumper to the Vehicle.

- Remove the stock steel bumper using a putty knife and a hammer if the bumper does not come loose after removing the bolts in the previous step. The frame sealant may cause the steel bumper to stick to the frame. See Figure 13. CAUTION: once the seal is broken, the bumper may fall if not properly supported.



Figure 13: Releasing the Stock Steel Bumper from the Vehicle Using a Putty Knife and Hammer

- Lower the air flow skirt by unclipping each side and pressing the skirt down as shown in Figure 14-15. Some of the hoses may need to be adjusted.

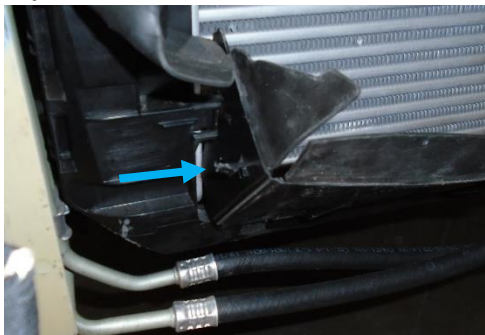

Figure 14: Air Flow Skirt Clip

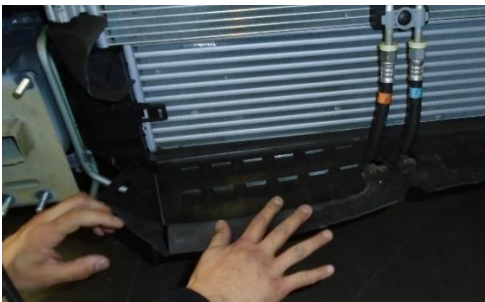

Figure 15: Air Flow Skirt Pressed Down

### Front Bumper Installation:

- Install the eight (8) provided M8 bolts with eight (8) split washers through the frame, from back to front, creating studs for the bumper to mount onto. Reference Figure 16.

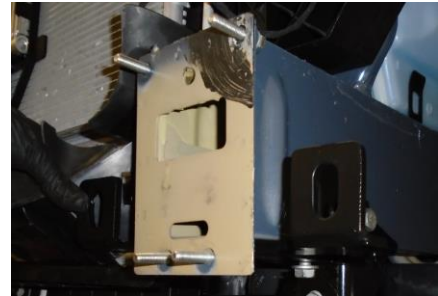

Figure 16: M8 Bolts Installed

- Loosen the three (3) bolts holding on each of the black steel crossmember underneath the radiator. The two (2) bolts on the sides of the frame may not be able to be fully removed, but the bottom bolt must be removed. (see Figure 17).

*PRO TIP: Only uninstall one side at a time to make re-installation easier.*

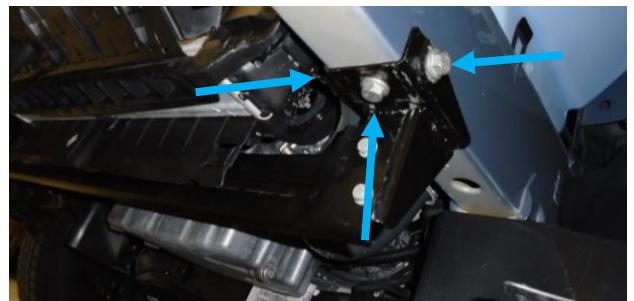

Figure 17: Engine Crossmember Bracket Factory Bolts (Driver Side Shown)

- Install the steel mounting bracket (see "Additional Parts" section) by sliding it into place on the correct side of the vehicle **over** each of the factory crossmember brackets.
- Reinstall the factory hardware through the supplied mounting brackets and through the factory crossmember brackets as applicable. Do not tighten hardware yet; allow the mounting bracket some play until entire bumper is mounted. Reference Figure 18.

NOTE: If installing on a Sprinter 3500, one bolt on the bottom of the mounting bracket is required. Ensure to properly install all the bolts from the frame to the back of the bumper.

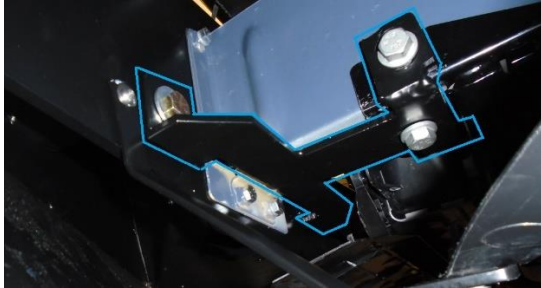

Figure 18: Installed Mounting Bracket

21. Press the air flow skirt down past the mounting brackets and adjust the hoses as needed.
22. Cut the plastic shrouds to clear around the new bumper as shown in Figure 19.



Figure 19: Plastic Shrouds Cut (left) and Uncut (right)

23. Mask off edges of headlight and front quarter panels using painter's tape to protect the vehicle during bumper installation as shown in Figure 20.

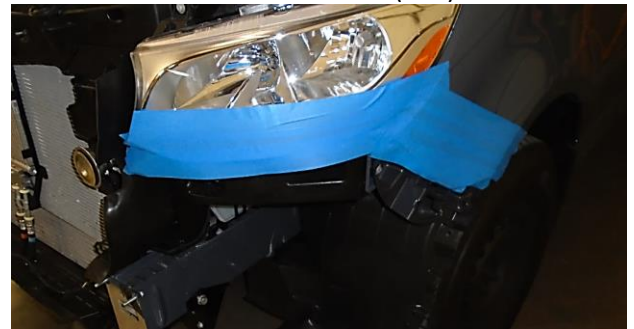

Figure 20: Masking of Headlight and Quarter Panel

### Front Radar Sensor Installation:

24. Install the front radar sensor into the sensor carriage by locating the two (2) protrusions on each side and rotating the sensor back into the carriage as shown in Figure 21. Depress the tab on top to secure the sensor.

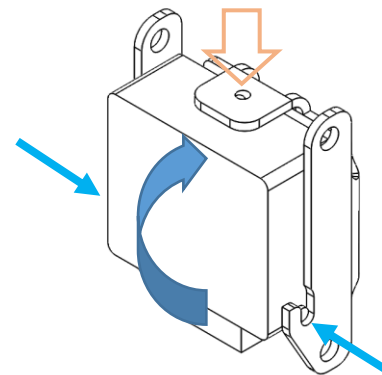
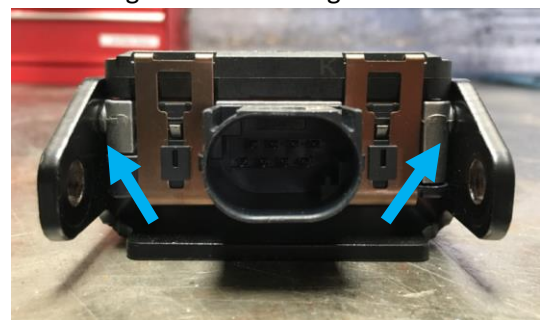

Figure 21: Sensor Assembly

25. Verify proper engagement of the sensor with the carriage as shown in Figure 22.



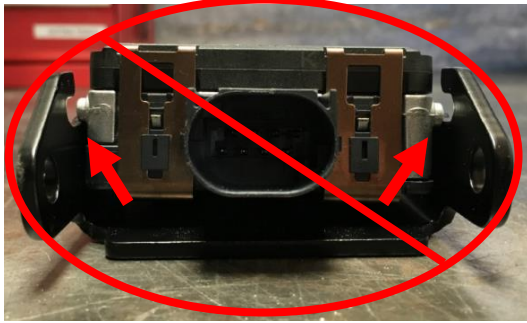

Figure 22: Acceptable (top) and Unacceptable (bottom) Sensor Engagement

26. Add zip tie(s) around sensor and sensor carriage for added stability. Reference Figures 23-25.



Figure 23: Feed a Zip Tie Between the Sensor and Sensor Carriage (Behind Sensor)



Figure 24: Pull the Zip Tie(s) Around the Front of the Sensor Connection



Figure 25: Tighten Zip Tie(s) Around Top of Sensor Carriage

27. Install sensor brackets onto the sensor carriage using the ¼"-20 x ¾" bolts, washer, and nuts provided. Reference Figure 23.

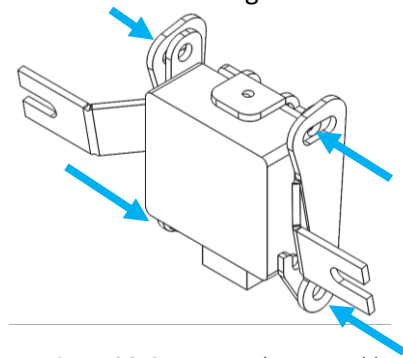

Figure 26: Sensor Bracket Assembly

28. Install sensor bracket assembly into front bumper utilizing the bolts holding the sensor window as shown in Figure 27.

PRO TIP: Make sure the sensor is level ( $\pm 1^\circ$ ) and as perpendicular to the road as possible ( $\pm 1^\circ$ ) while installing into the bumper – this will make re-calibrating the front sensor much easier.

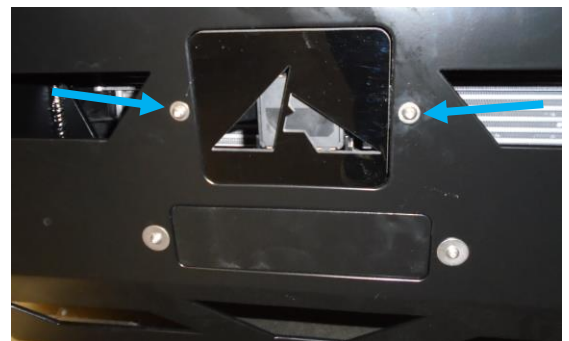

Figure 27: Collision Sensor Installation

29. Install winch into bumper if applicable.  
30. Re-install plastic shrouds into place after cutting (See Figures 11 & 19).

31. Lift the bumper onto the pre-installed bolts using two people. Ensure the air flow skirt seals underneath the winch mounting plate.
32. Connect front radar sensor through the back of the bumper.
33. Align the bumper onto the vehicle to the desired height using the slots in the back of the bumper.
34. Install washer, split washer, and M8 nuts onto the eight (8) pre-installed bolts.
35. Tighten two (2) of the M8 bolts, one (1) on each side, to hold the bumper in desired position.
36. Install ½"-13 bolts with washers through the mounting brackets and through the back of the bumper. Install a washer and nut onto each bolt.
37. Adjust bumper into final position.
38. Tighten all hardware:
  - a. ½"-13 bolts
  - b. M8 bolts
  - c. Factory bolts into frame at crossmember.
39. Install the air temperature sensor bracket onto upper, inner M8 bolt on the driver's side and insert the air temperature sensor into the slot facing into the light hole (reference Figure 28).



*Figure 28: Air Temperature Sensor Installed onto Back Plate of Bumper*

40. Tuck fender plastic underneath outer edges of new front bumper.
41. Install the fender plastic supports. Attach to the back of the front bumper and to the inner most plastic rivet hole in fender plastic using the remaining ¼" hardware. Reference Figure 29.

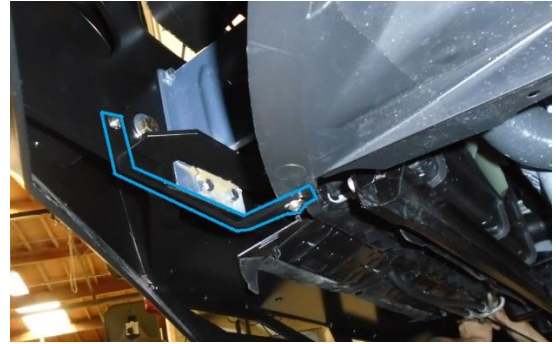

*Figure 29: Fender Plastic Support Brackets*

42. Re-install the grille onto vehicle using the vertical tabs on bumper to locate grille tabs shown in Figure 3 and 30.



*Figure 30: Grille Tabs Installed*

43. Re-install the three (3) torx bolts to secure the grille shown in Figure 1.
44. Enjoy your new Aluminess bumper!





Aluminess Products, Inc. (Aluminess) Warranty

1. Lifetime Warranty. Aluminess provides a lifetime warranty of its products to the original retail purchaser provided such products are installed correctly according to the official Aluminess installation instructions. Any modification to the original product design, function or use of any Aluminess products will void the Aluminess warranty. Aluminess will have sole discretion to determine warranty eligibility for any and all Aluminess products sold to any purchaser.

2. Limited Remedies. Subject to any limitations and exclusions described herein, and subject to Aluminess' determination of warranty eligibility, Aluminess will remedy defects in product materials and/or workmanship of any product by repairing or replacing such defective product, which shall be within Aluminess' sole discretion, without charge for parts or labor. Aluminess may elect in its sole discretion not to replace a defective product and issue the purchaser a refund equal to the purchase price of any defective product or purchaser may elect to receive a credit (equal to such refund) toward the purchase of new Aluminess products. Repair or replacement of a defective product or providing a refund or credit to purchaser will be purchaser's exclusive remedy under this warranty. Damage to a purchaser's vehicle, cargo and/or any other person or property is expressly excluded from the Aluminess warranty.

3. Modification. Aluminess products are designed to be mounted to factory equipped vehicles. Aftermarket additions to such vehicle may or may not require modification of an Aluminess product. The Aluminess warranty does not extend to any Aluminess products that are modified to fit around other otherwise accommodate or be compatible with any aftermarket vehicle accessories or alterations. Aluminess does not guarantee fitment with any other aftermarket accessories or modified vehicle, and it is up to purchaser to determine fitment prior to purchasing any Aluminess product.

4. Damage. Damage to Aluminess products due to normal wear and tear, including, but not limited to, cosmetic issues and superficial scratches, or structural damage to an Aluminess product in connection with any vehicle collisions or other structural degradation in connection with the use of such vehicle (on road or off road) will not be covered by the Aluminess warranty. Additionally, any product user's misuse, neglect, overloading, improper maintenance or improper installation or repair of any Aluminess products are not covered under the Aluminess warranty.

5. Use of the Products. Aluminess products are designed for off road vehicle use. Installing Aluminess products on a vehicle may exceed the factory designed capabilities of such vehicle and could potentially lead to vehicle damage. Aluminess will not be responsible for any damage caused to a purchaser or user's vehicle or any vehicle accessories caused by the use of any Aluminess products. It is to the sole responsibility of purchaser to inspect and ensure that the intended vehicle and Aluminess products are suitable and compatible for travel on road and off road. No seller nor any manufacturer of Aluminess products will be liable for any loss, damage or injury directly or indirectly arising from the use of any Aluminess products. Before using any Aluminess products, the purchaser or user will determine the suitability of the product(s) for their intended use(s) and the purchaser or user shall assume all responsibility and risk in connection therewith.

6. DISCLAIMER. THE ALUMINESS WARRANTY IS EXPRESSLY MADE IN LIEU OF ANY AND ALL OTHER WARRANTIES, AND EXCEPT FOR THE ALUMINESS WARRANTY SET FORTH HEREIN, ALUMINESS MAKES NO WARRANTY WHATSOEVER WITH RESPECT TO ANY ALUMINESS PRODUCT, INCLUDING ANY WARRANTY OF MERCHANTABILITY AND FITNESS FOR A PARTICULAR PURPOSE, WHETHER EXPRESS OR IMPLIED BY LAW, COURSE OF DEALING, COURSE OF PERFORMANCE, USAGE OF TRADE, OR OTHERWISE.

EXCEPT FOR PURCHASER'S LIMITED REMEDIES SET FORTH HEREIN, IN NO EVENT WILL ALUMINESS BE LIABLE FOR ANY LOST PROFITS, LOST SALES, OR FOR ANY CONSEQUENTIAL, DIRECT, INDIRECT, INCIDENTAL, SPECIAL, EXEMPLARY OR PUNITIVE DAMAGES OR FOR ANY OTHER DAMAGES OF ANY KIND OR NATURE.

7. Compliance. Aluminess cannot guarantee that its products comply with all Federal, State, and/or local laws. Purchaser is advised to review local vehicle codes for compatibility prior to purchase to ensure that the installation and use of any Aluminess products does not violate any applicable laws.

8. Warranty Claim Submission. Purchaser will responsible for returning any defective product to Aluminess for warranty consideration and purchaser may be responsible for all costs associated with shipping the product to and from Aluminess. Prior to returning any product for warranty, purchaser must contact Aluminess Products Inc. for proper authorization.