

GOBI TOYOTA FJ CRUISER FULL SIZE ROOF RACK INSTALLATION INSTRUCTIONS

Guidelines:

When using Load Carriers and Accessories, the user must understand the precautions. The points listed below will assist you in using the rack /carrier system and will encourage safety.

- For quality fits and safty, use only the recommended rack or accessory. Do not assume an accessory will fit, always check with dealer when obtaining new accessories. Use only approved accessories on load carriers. Using other brands will void your warrenty.
- Make sure all knobs, bolts, screws, straps, and locks are firmly attached, tightened and locked before every trip. Knobs, bolts, screws, straps, and locks must be periodically inspected for signs of wear, corrosion, and fatigue. Check your load at stops during the trip to insure continued fastening security.
- Check local and state laws governing projection of objects beyound the width of a vehicle. **Be aware of the width and height of your cargo since low clearance branches, bridges, and parking garages can affect the load** All cargo will affect the vehicle's driving behavior. Never drive with any lock, knob, or rack in an open or unlocked position. All long loads such as, but not limited to sailboards, surfboards, kayaks, canoes, and lumber must be tied down front and rear to the bumpers or tow hooks, of the vehicle.
- Remove your rack accessories when they are not in use, before intering car washes, prior to taking in your vehicle for service, and whenever clearance may be an issue.
- All locks must be turned and moved periodically to insure smooth operation. Use graphite or similar dry lubricant to help this. Locks are designed to deter vandalism and theft. Remove valuable gear if your vehicle is unattended for an extended period. Place at least one key in the glove compartment.
- For safety to your vehicle and rack system, obey all posted speed limits and traffic cautions. Adapt your speed to the conditions of the road and the load being carried.
- Do not use load carriers and accessories for purposes other than those for which they were designed. Do not exceed their carrying capacity.
- Consult with your dealer if you have any questions regarding the operations and limits of this product. Review all instructions carefully.

GOBI TOYOTA FJ CRUISER FULL SIZE ROOF RACK INSTALLATION INSTRUCTIONS

Included in kit

Letter	Description	Location	Quantity
A	GOBI TOYOTA FJ FULL SIZE ROOF RACK	Main box	1
B	FAIRING RUBBER PROTECTIVE STRIP	pre-assembled	1
C	FAIRING	banded to rack	1
D	FAIRING BRACKETS (pre-assembled to fairing)	pre-assembled	3
E	FAIRING BRACKET HARDWARE CONTENTS: 3- 1/4-20x1 Button head screw SS 6- 1/4" Black Nylon washer 3- 1/4-20 Nut SS	BAG #2 Hardware Box	1
F	GOBI SUPPORT BRACKETS	Hardware Box	6
G	GOBI ROOF MOUNT BRACKET HARDWARE CONTENTS: 6- Cover plates black powder coated 18- Flat double hole Rubber gasket 12- 1/2" x 3/4" Nylon spacer washers (13RSSR0207) 12- M8 x 50 Mounting screws SS 12- 5/16" Stainless lock washers 12- 5/16" Stainless water proof washer 1- M-5 Metric allen wrench	BAG #3 Hardware Box	1
H	GOBI RACK BRACKET HARDWARE CONTENTS: 12- 3/8"-16 x 1" SS Hex Bolt 24- 3/8" Flat washers 12- 3/8" Nylock nut 6- Rubber pads black 1- Packet Anti-seize lubricant	BAG #4 Hardware Box	1

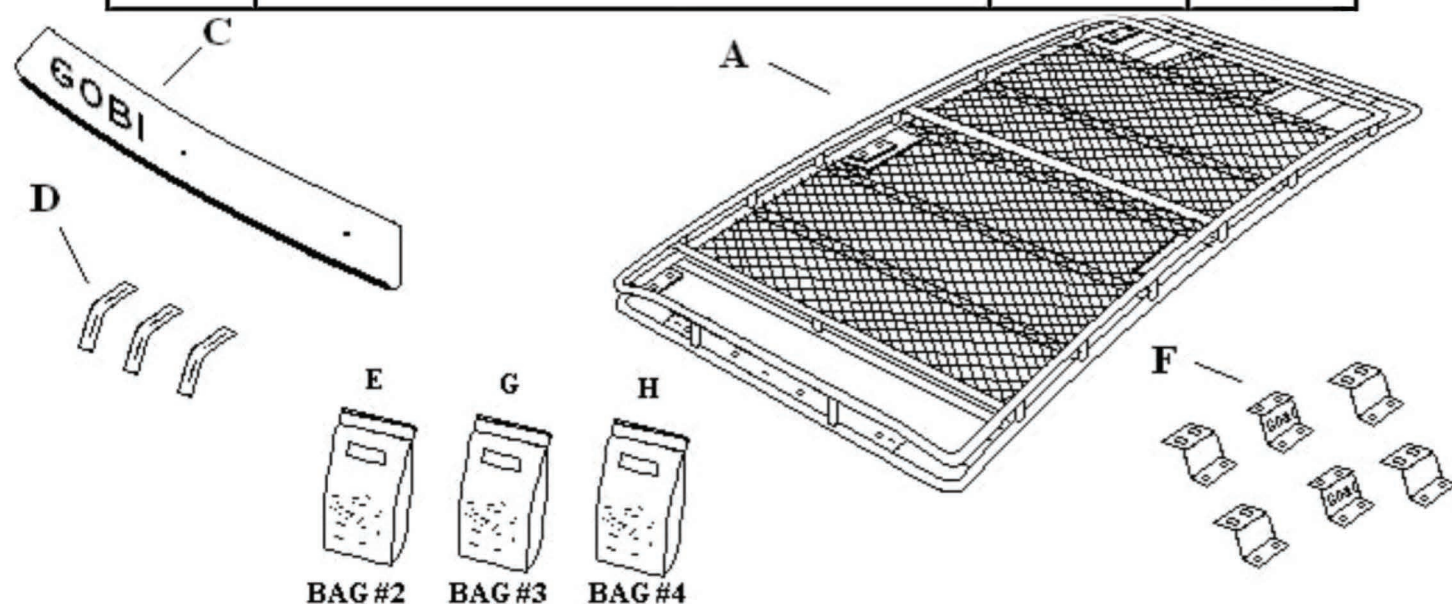

GOBI TOYOTA FJ CRUISER FULL SIZE ROOF RACK INSTALLATION INSTRUCTIONS

The rack must be inspected before each use to make certain attachments are secure, and for evidence of Wear. Misuse of the rack or failure to observe the manufacturer's instructions as to installation, proper Attachment and maintenance will void any warranties that may be implied by law.

INSTALLATION INSTRUCTIONS:

- 1- Using the hardware list on page 2 of the Gobi instruction guide check and verify that all hardware is present prior to installation.
- 2- Read all instructions carefully prior to installation.
- 3- Refer to page 5 Fig. 1 push on access cover plate "A" in the direction of the arrow while lifting the access cover plate with a small screwdriver. Remove all 6 cover plates in the same manner.
- 4- Refer to page 5 Fig. 2 remove all 12 screws "B". When loosening screws "B" switches from one screw to the other until both screws are finally removed from each mounting point. **DO NOT REMOVE ONE SCREW AT A TIME AS THIS MAY TWIST, CRACK OR DISLodge THE THIN WHITE NYLON WATER PROOF SEAL / NUTPLATE (C2) PROTRUDING OUT FROM THE ROOF TOP AS SHOWN ON PAGE 5 FIG. 3 "C2" AND PAGE 6 FIG. 5A "C2".** Apply the same screw extraction method if you are removing the originally installed factory roof rack.
- 5- Refer to page 5 Fig. 2 and remove cover plate bracket "C1" from roof top by pulling up in the directions of the arrows and dislodging the bracket from the surface of the vehicle. The bracket is held in place by a thin layer of clear double back tape simply pull up and remove. Apply the same procedure to the remaining brackets then clean the surface of the vehicle under each removed bracket and around each white nylon water proof seal "C2" with denatured alcohol as shown in Fig. 3. An actual image of bracket "C1" is shown on page 6 Fig. 5 a prior to removal you can see the nylon water proof tube shown as "C2". Fig. 5 illustrates bracket "C1" correctly removed from the vehicle.
- 6- Refer to page 5 Fig. 3 place one black rubber gasket (14) located in Bag #3 over and around each white nylon water proof tube/nut plate "C2" as shown in Fig. 3 make certain to press down on the rubber gasket around each nylon tube and to the surface of the vehicle to provide a good fit. Remove two 1/2" white nylon spacers from Bag #3 and place them directly onto black rubber gasket (14) over and around each water proof tube "C2" as shown in Fig. 3. Place another black rubber gasket (14) over the top of the two nylon spacers (15) followed by cover plate (E) also located in Bag #3 as shown in Fig. 3. Place a final rubber gasket (14) over cover plate (E). Refer to page 5 Fig. 4 use two M8 x 40 metric screws located in hardware Bag #3 and slide each screw (9) through lock washer, water proof washer, Gobi support bracket #8 then through rubber gasket (14) cover plate (E) and all water proof sub assembly just installed below and finally into vehicle roof top water proof nylon tube / nut plate (C2). Thread in the M8 x 40 screws using the supplied metric Allen wrench located in Bag #3 switching from one screw to the other while tightening to prevent the dislodging or cracking of the water proof nylon tube and nut plate below. Snug down screws only at this time "Allow for some bracket movement" Refer to page 7 for an actual close up view of a properly installed Gobi support bracket assembly. Install all remaining support brackets in the same manner.

GOBI TOYOTA FJ CRUISER FULL SIZE ROOF RACK INSTALLATION INSTRUCTIONS

The rack must be inspected before each use to make certain attachments are secure, and for evidence of Wear. Misuse of the rack or failure to observe the manufacturer's instructions as to installation, proper Attachment and maintenance will void any warranties that may be implied by law.

INSTALLATION CONTINUED:

- 7- Refer to page 5 Fig. 4 using at least two people carefully place the Gobi roof rack (11) in position on top of all 6 Gobi support brackets (8) as shown. Install all 6 rubber pads (10) located in Bag #4 between the Gobi roof rack's welded in tabs (11a) and the Gobi support brackets (8) as shown. Using the 3/8-16 x 1" hex bolts located in Bag #4 along with a 3/8" flat washer install all 12 bolts and washers (12) through the Gobi welded in tabs (11a) then through Gobi support bracket (8). Thread all 12 3/8" nuts and flat washers located in Bag #4 to each bolt as shown on page 5 Fig. 4 (12) and snug down only at this time. Align each Gobi support bracket (8) to the roof rack and the vehicle as shown on page 8 Fig. 7 (H) and page 7 Fig. 6. Once bracket alignment is completed fully tighten each Gobi support bracket to the roof top using only the 5mm Allen wrench supplied to prevent over tightening. Final support bracket installation shown on page 7 Fig. 6. Continue by fully tightening the Gobi roof rack (11) to the support brackets as shown on page 5 Fig. 4.
- 8- Refer to page 8 Fig. 7 (2) fairing; fairing comes pre-assembled with fairing brackets (4) attached. The position of each attached fairing bracket may not be fixed at the proper height for your particular roof line. Adjustments may have to be made in order for the fairing to conform correctly to your vehicle's roof line. Begin by attaching the fairing's center bracket to the middle slot (5a) of the Gobi roof rack light bar (5) shown on page 8 Fig. 7. Use the Stainless 1/4" button head screws, flat black nylon washers and 1/4" nylock nut supplied in Bag #2. Provide approximately a 2" gap between the fairing and the Gobi rack outer tube as shown in Fig. 8a. Tighten down the center screw and nut at this time. Proceed to either the passenger or driver side and pull the fairing in the direction of the arrows in Fig. 8 letter (F) and (G) while pushing down on the fairing towards the roof top at the same time. Pull each side until fairing either makes contact with the Gobi roof rack or comes in close proximity. Align fairing bracket (4) to the Gobi light bar fairing slots at the end of the Gobi light bar (5) and insert a 1/4" button head screw and washer through fairing bracket (4) then through the Gobi light bar slot and secure the fairing in place with a 1/4" black nylon washer and nylok nut. Proceed to the opposite side and continue attaching the fairing in the same manner. Be sure that the fairing throughout its length is making contact with the roof top as snug as possible, fairing brackets may need to be adjusted either up or down and in some cases you may bend the fairing bracket to accommodate the final result. Once the fairing is in the proper position tighten all fairing brackets screws firmly. Roof rack installation is complete.

GOBI TOYOTA FJ CRUISER FULL SIZE ROOF RACK INSTALLATION INSTRUCTIONS

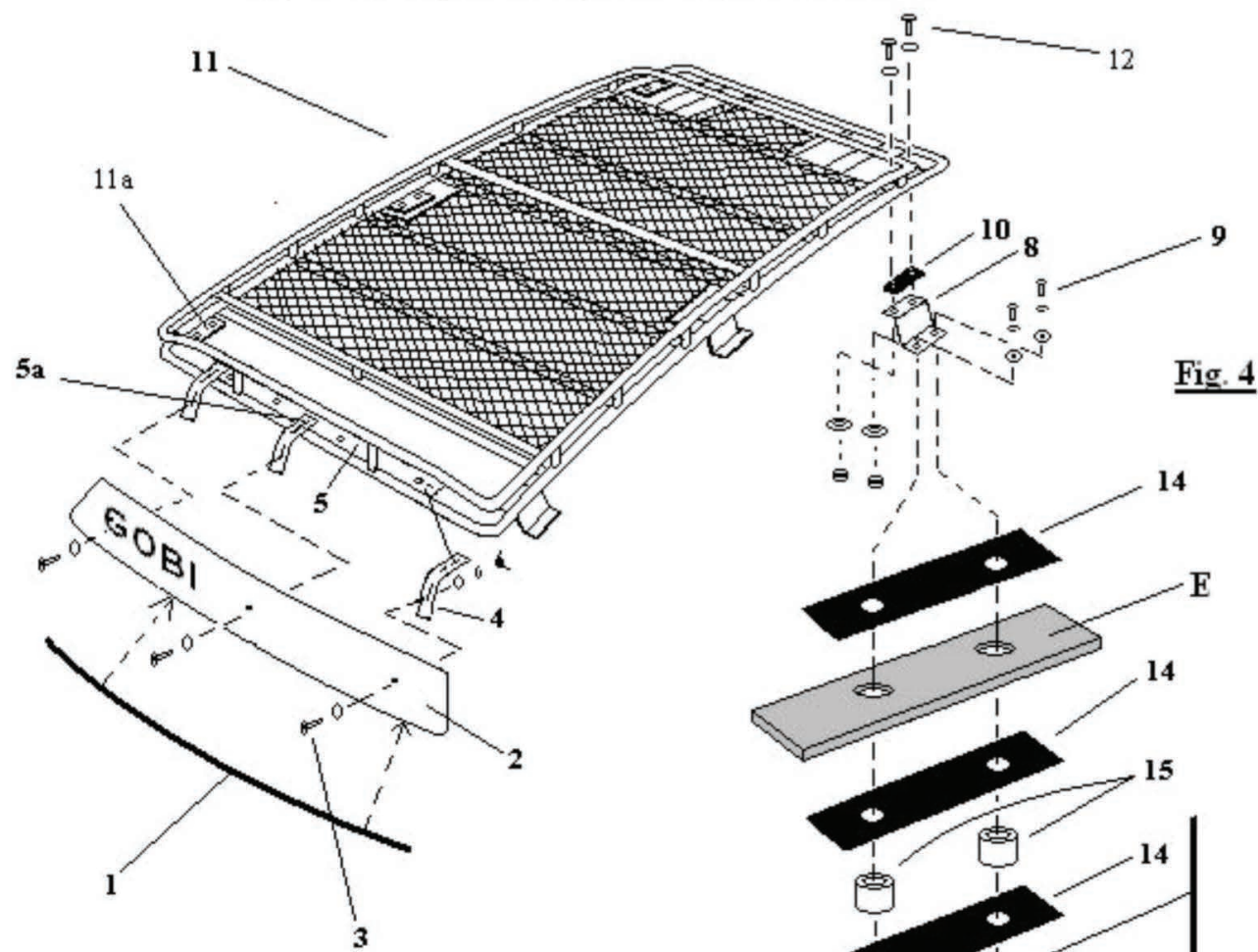

Clean surface of all debris and with denatured alcohol

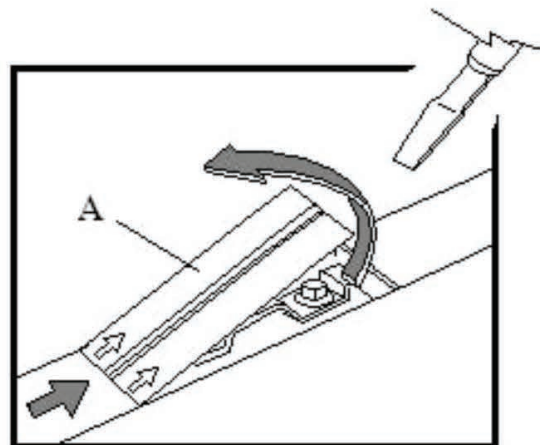
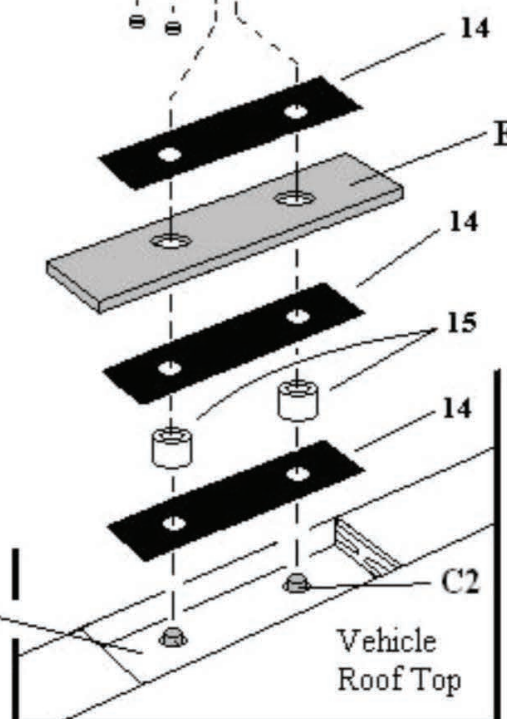

Fig. 1

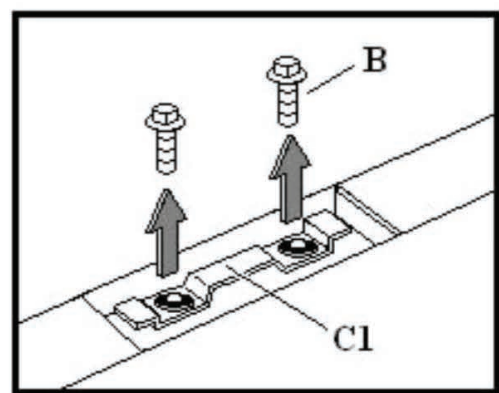

Fig. 2

GOBI TOYOTA FJ CRUISER FULL SIZE ROOF RACK INSTALLATION INSTRUCTIONS

FIG. 5 BELOW SHOWS THE COMPLETE BRACKET C1 REMOVED FROM THE VEHICLE ROOF TOP. FIG. 5A PROVIDES A BETTER VIEW OF BRACKET C1 PRIOR TO REMOVAL. ONCE REMOVED DO NOT DISTURBE WHITE NYLON TUBES C2. CLEAN COMPLETE SURFACE AREA AROUND NYLON TUBES C2 WITH DENATURATED ALCOHOL



GOBI TOYOTA FJ CRUISER FULL SIZE ROOF RACK INSTALLATION INSTRUCTIONS

BELOW ILLUSTRATES THE PROPER INSTALLATION OF
THE GOBI FJ SUPPORT BRACKETS AND COVER PLATES
USING ALL GOBI SUPPLIED HARDWARE

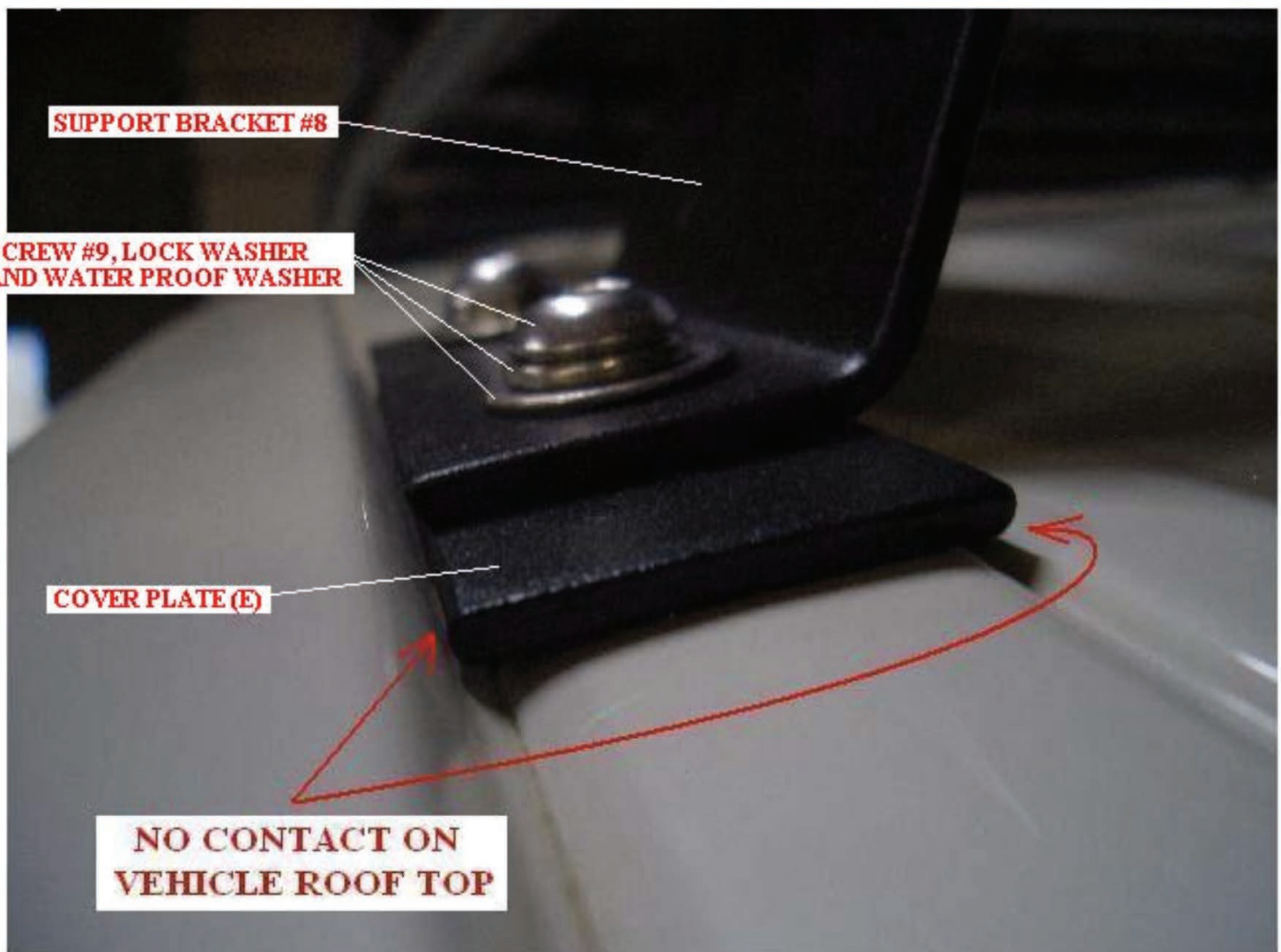

Fig. 6

GOBI TOYOTA FJ CRUISER FULL SIZE ROOF RACK INSTALLATION INSTRUCTIONS

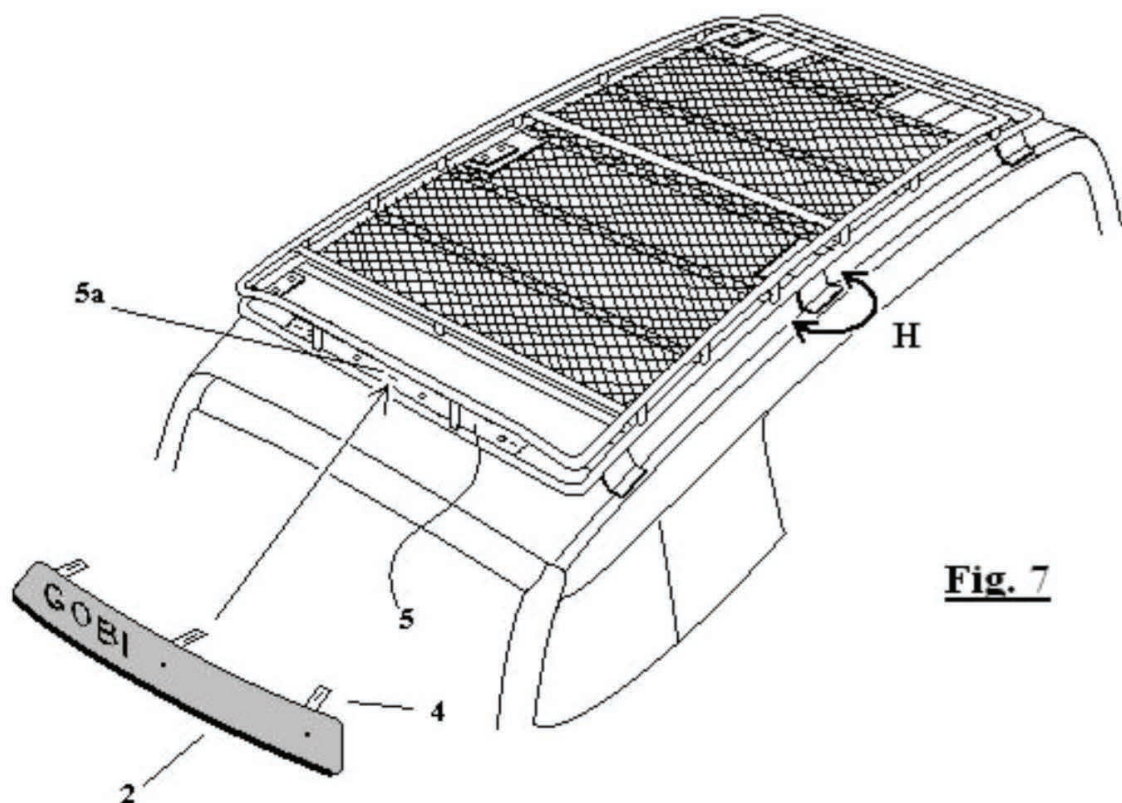

Fig. 7

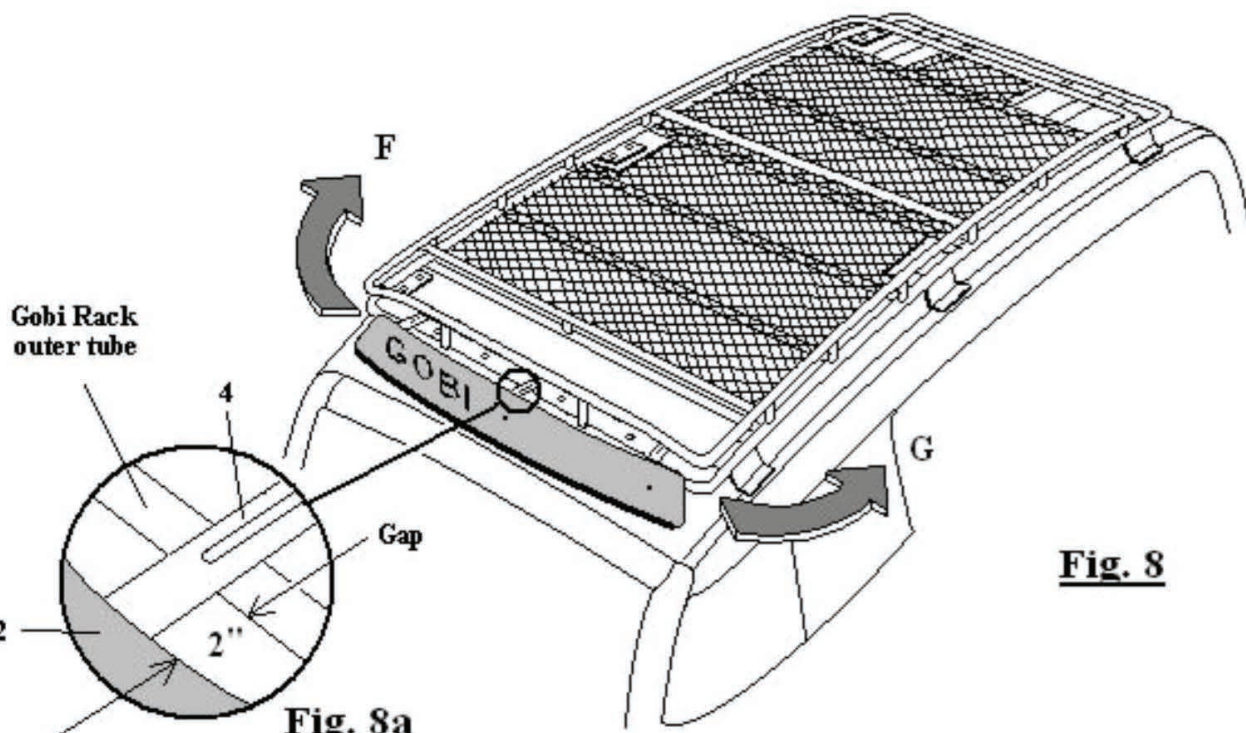

Fig. 8

Fig. 8a