



# START HERE!

## READ ME FIRST

Don't be a hero and muscle through this without first reading these fitting instructions! Improper installation of this gear may void certain aspects of your warranty.

Before you begin, take a moment and open all your Front Runner rack kit boxes and gather the assembly instructions for the various components.

A complete kit will contain:

1. A Front Runner Mounting System specific to your vehicle
2. A Front Runner Rack Tray or Load Bar Slats

This document will guide you through the assembly of the mounting system and assist you in fitting the roof rack tray or load bars to your specific vehicle.

Please refer to the next page for a list of all the components, quantities and tools required.

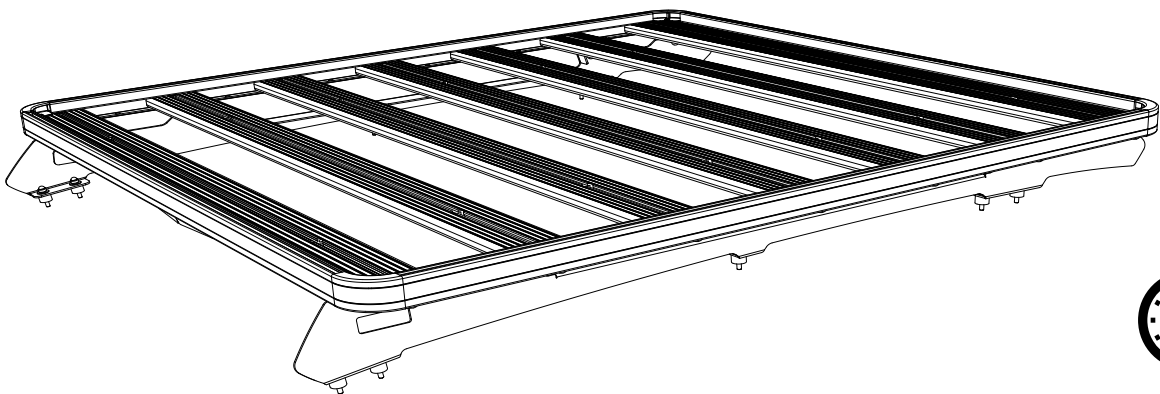

### IMPORTANT WARNING!

IT IS CRITICAL THAT ALL FRONT RUNNER PRODUCTS BE PROPERLY AND SECURELY ASSEMBLED AND ATTACHED TO YOUR VEHICLE. IMPROPER ATTACHMENT COULD RESULT IN AN AUTOMOBILE ACCIDENT, AND COULD CAUSE SERIOUS BODILY INJURY OR DEATH. YOU ARE RESPONSIBLE FOR ASSEMBLING AND SECURING ALL FRONT RUNNER PRODUCTS TO YOUR VEHICLE. CHECKING THE ATTACHMENTS PRIOR TO USE, AND PERIODICALLY INSPECTING THE PRODUCTS FOR ADJUSTMENT, WEAR AND DAMAGE. THEREFORE YOU MUST READ AND UNDERSTAND ALL OF THE INSTRUCTIONS AND PRECAUTIONS SUPPLIED WITH YOUR FRONT RUNNER PRODUCT PRIOR TO INSTALLATION OR USE. IF YOU DO NOT UNDERSTAND ALL OF THE INSTRUCTIONS AND CAUTIONS, OR IF YOU HAVE NO MECHANICAL EXPERIENCE AND ARE NOT THOROUGHLY FAMILIAR WITH THE INSTALLATION PROCEDURES, YOU SHOULD HAVE THE PRODUCT INSTALLED BY A PROFESSIONAL INSTALLER OR OTHER QUALIFIED PERSONNEL.

# 1

## GET ORGANIZED

Here is what you are looking at for FATT002

### IN THE BOX

1	2 X	Foot Rail; 1xLH, 1xRH
2	10 X	Nut Cap M6
3	10 X	Hex Bolt M6x35
4	10 X	Spring Washer M6SS
5	10 X	Flat Washer M6x19x1ss
6	2 X	Spacer (19x12.58x15)
7	8 X	Hex Bolt M8x20
8	8 X	Flat Washer M8x16x1.6ss
9	8 X	Nyloc Nut M8
10	8 X	Nut Cap M8
11	8 X	Spacer (19x12.58x20)

### TOOLS NEEDED



FIGURE 1.1

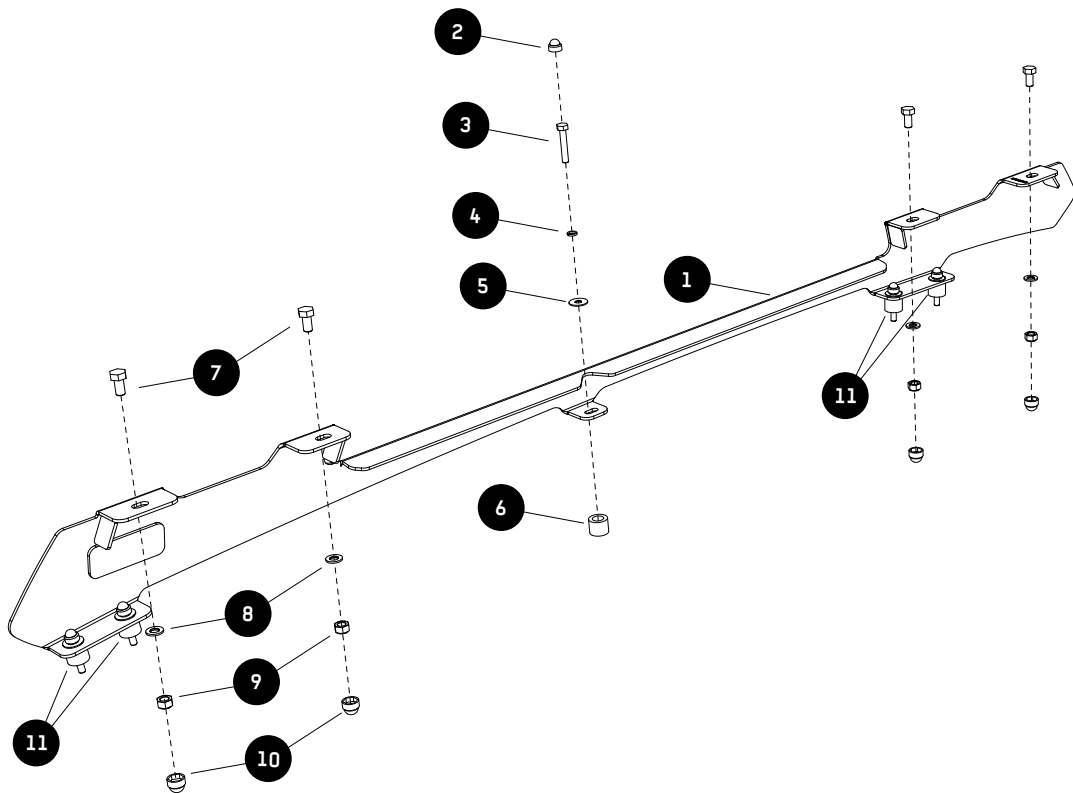

2.1



Using a flat screwdriver, starting from the front of the vehicle, lift and remove the two ditch moldings running along either side of the roof.

Remove the tape covering the ten mounting points in the gutter (five on each side). Insert and hand tighten the ten M6x35 hex bolts (item 3) supplied to the mounting points.

Starting at the front of the vehicle, refit the ditch molding. Whenever you reach one of the hex bolts that you have inserted, take a white marking pen and mark the top of the hex bolt. While the white "paint" is still wet press the ditch molding onto the head of the bolt, transferring the position of the bolt head onto the underside of the ditch molding. Repeat this process for all the bolts on both ditch moldings.

2.2

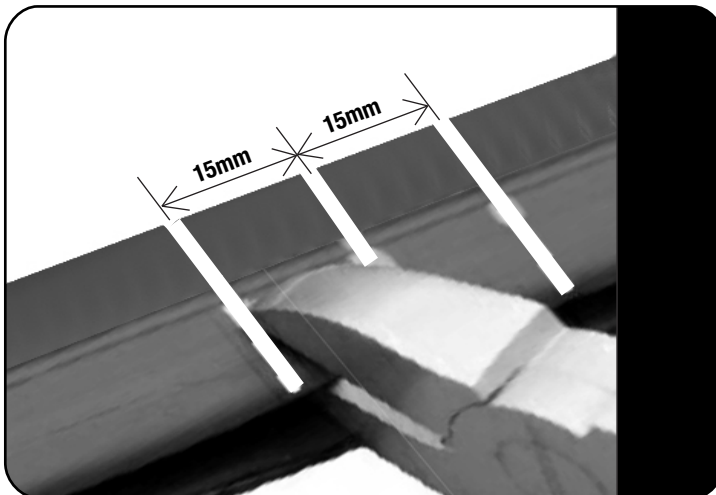

Working on the underside of the ditch molding, measure and mark a line 15mm either side of your original markings from Step 2.1 as shown in 2.2.

Using a pair of side cutters and a utility knife, remove the marked section of ditch molding as shown in Step 2.2 through to Step 2.4.

2.3

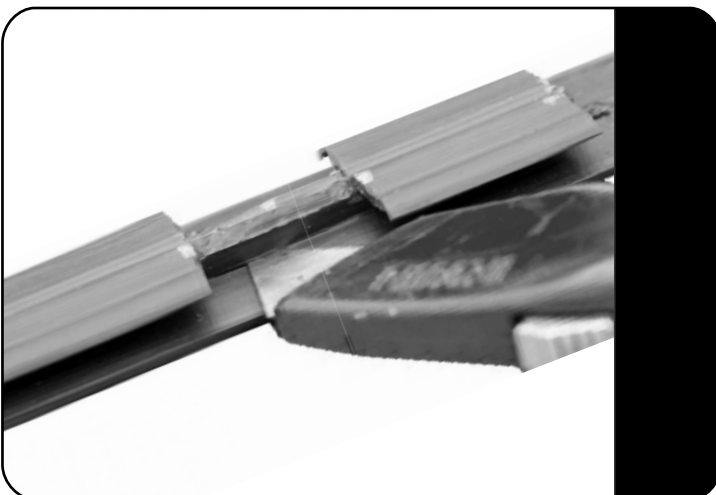

Refer to step 2.2.

**2****FIT AND SECURE**

2.4

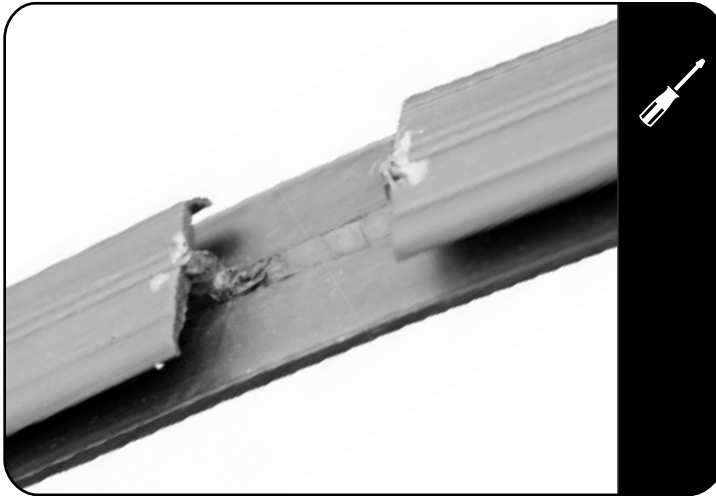
 Refer to step 2.2.

2.5

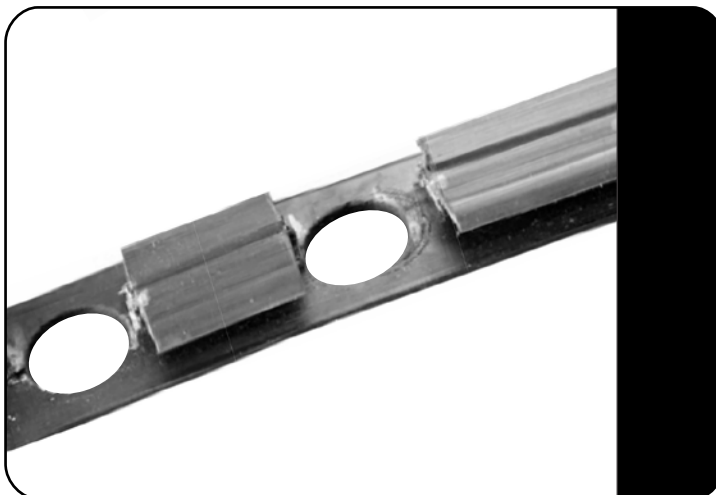
 Using a 22mm hole punch (Recommended) or hole saw, punch/drill holes through the ditch molding on each of your markings.

2.6

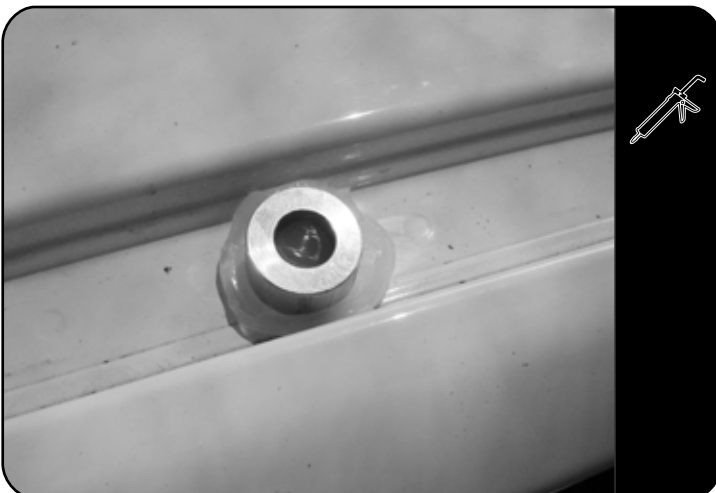
 Clean the area around each mounting point using a rag and denatured alcohol. Place a small amount of silicone over each mounting point followed by one of the aluminium spacers supplied as shown. There are ten spacers in total. The shorter spacers (item 6) must be used on the two middle mounting points and the longer spacers (item 11) must be used on the front and rear mounting points on either side of the vehicle. Refit the ditch molding, lining up the holes in the ditch molding with the aluminium spacers.

**2****FIT AND SECURE**

2.7



Place the side rails onto the vehicle, lining up the holes in the base of the side rails with the aluminium spacers. There is a left and a right hand side rail. The product sticker must be on the front outer side of the vehicle.

Hand tighten the foot rails to the roof using the M6x35 hex bolts (item 3) M6 spring washers and M6x19x1 flat washers supplied.

Measure the distance from the top of the windscreen to the first hole in each rail. Ensuring that the left and right hand sides are of equal distance. Fully tighten the bolts. Use M6 nut caps (Items 2) to finish off the nuts.

**3****FIT AND SECURE**

3.1

Refer to RRSUNI when assembling your Slimline II Tray.



3.2

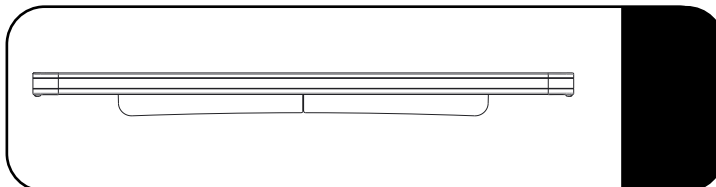

Make sure that the wind deflector is installed before you proceed to the next step.

3.3

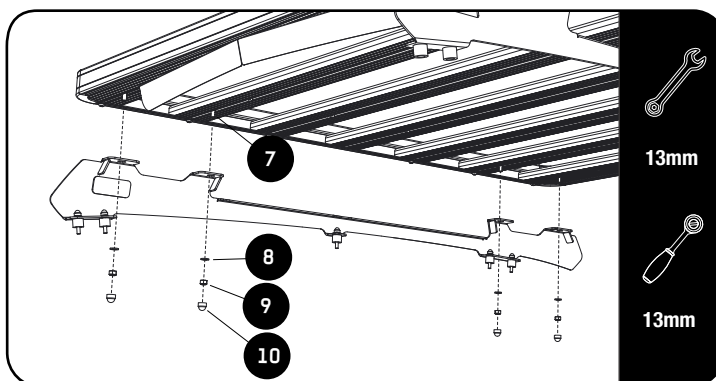

Slide item 7 into the t-slots shown in step 3.3. Loosely fit the rack to the foot rail by using items 7, 8 and 9.

3.4

Centre the rack and fully tighten . Use M8 nut caps (Items 10) to finish off the nuts.

4

## COMPLETION

4.1



**Congratulations. You did it. Take a step back and admire your work!**

5

## INSTALL OTHER VEHICLE AND RACK ACCESSORIES

Now's the time to visit your favorite Front Runner Dealer in person or online.