**READ ME !** 

Thank you for purchasing a Front Runner Toyota 4Runner Ladder.

Before you start, take a moment to familiarize yourself with the Fitting Instructions and the included components.

Refer to Page 2 for a list of all the components, quantities and tools required.

IMPORTANT WARNING! 

IT IS CRITICAL THAT ALL FRONT RUNNER PRODUCTS BE PROPERLY AND SECURELY ASSEMBLED AND ATTACHED TO YOUR VEHICLE. IMPROPER ATTACHMENT COULD RESULT IN AN AUTOMOBILE ACCIDENT, AND COULD CAUSE SERIOUS BODILY INJURY OR DEATH. YOU ARE RESPONSIBLE FOR ASSEMBLING AND SECURING ALL FRONT RUNNER PRODUCTS TO YOUR VEHICLE, CHECKING THE ATTACHMENTS PRIOR TO USE, AND PERIODICALLY INSPECTING THE PRODUCTS FOR ADJUSTMENT, WEAR AND DAMAGE. THEREFORE, YOU MUST READ AND UNDERSTAND ALL OF THE INSTRUCTIONS AND PRECAUTIONS SUPPLIED WITH YOUR FRONT RUNNER PRODUCT PRIOR TO INSTALLATION OR USE. IF YOU DO NOT UNDERSTAND ALL OF THE INSTRUCTIONS AND CAUTIONS, OR IF YOU HAVE NO MECHANICAL EXPERIENCE AND ARE NOT THOROUGHLY FAMILIAR WITH THE INSTALLATION PROCEDURES, YOU SHOULD HAVE THE PRODUCT INSTALLED BY A PROFESSIONAL INSTALLER OR OTHER QUALIFIED PERSONNEL.

NOTE: Front Runner will not be responsible for any damage caused by the failure to install the product according to these instructions.

Please call us if you have any questions about the installation of this product.



1 GET ORGANIZED

IN THE BOX

1	1 X	Ladder Top Step Bracket
2	2 X	Ladder Side Profile
3	1 X	Bottom Mount Bracket
4	1 X	Bottom Clamp Bracket
5	1 X	Bottom Inner Mount PLT
6	3 X	Ladder Step
7	6 X	Thread Forming Screw M6 x 25
8	6 X	M6 x 16 Flange Button Head Bolt
9	3 X	M6 x 25 Button Head Bolt
10	4 X	M8 x 30 Button Head Bolt
11	4 X	Aluminium Spacer 10mm
12	3 X	M6 Cage Nut
13	4 X	M8 Nyloc Nut
14	6 X	M6 Nyloc Nut
15	6 X	M6 Nut Cap

IN THE BOX

16	4 X	M8 Nut Cap
17	1 X	U-Channel Rubber (200mm Long)
18	1 X	M8 x 45 Button Head Bolt
19	1 X	M8 Hex Nut

TOOLS NEEDED

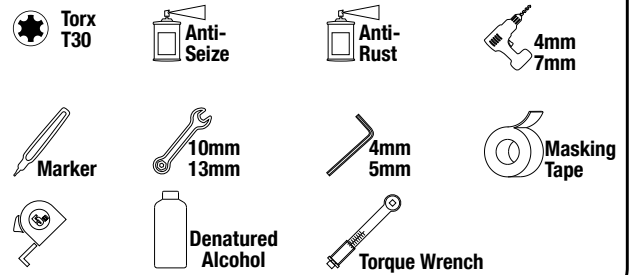
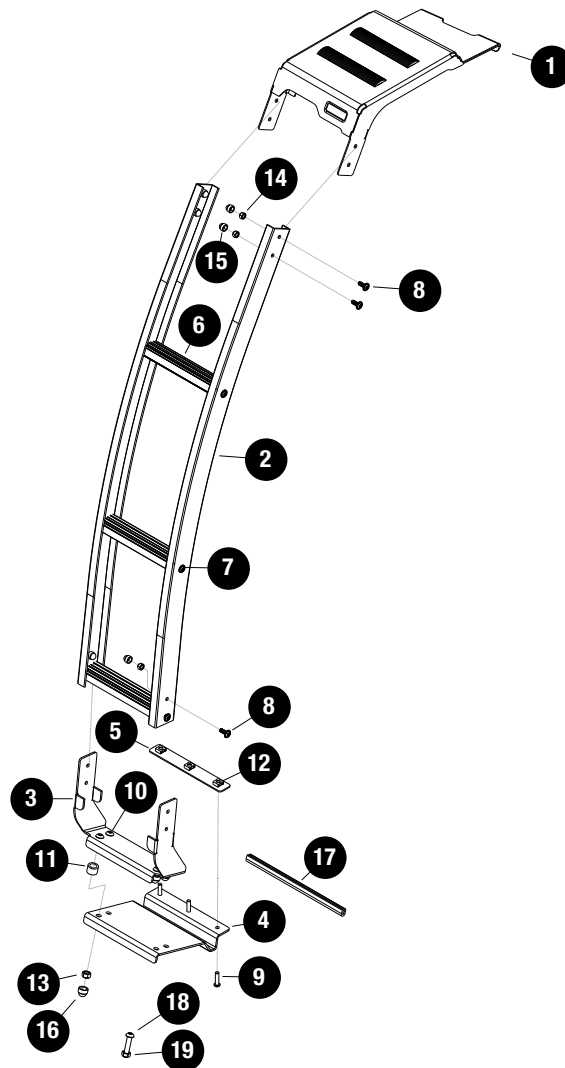

FIGURE 1.1



2

FIT AND SECURE

2.1

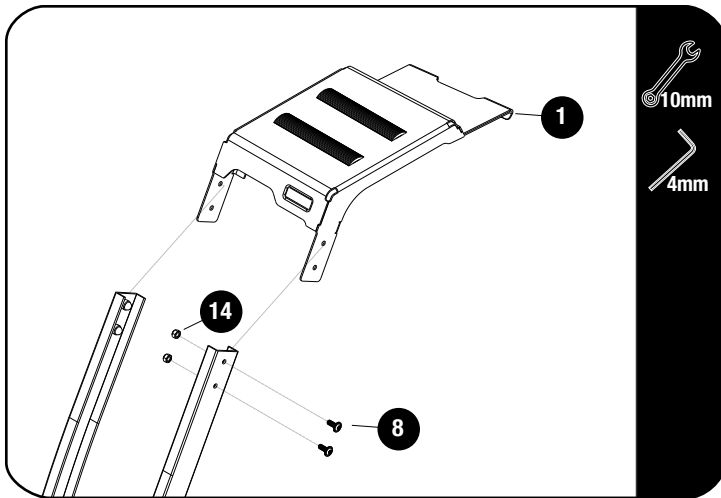

Loosely assemble both Ladder Side Profiles (Item 2) to the Ladder Top Step Bracket (Item 1) using the Top Mount Brackets, M6 x 16 Flange Button Head Bolts and M6 Nyloc Nuts (Items 8 & 14).

2.2

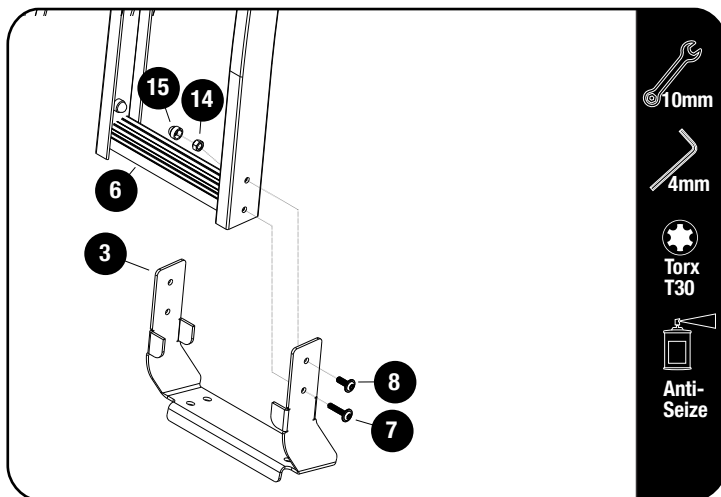

Apply a little Anti Seize / oil on Thread Forming Screws before inserting. Note these are thread forming screws.

Secure the Bottom Mount Bracket and Ladder Rungs (Item 3 & 6) to the Ladder Side Profiles (Item 2) using M6 x 25 Thread Forming Screws, M6 x 16 Flange Button Head Bolts and M6 Nyloc Nuts (Items 7, 8 & 14). Fully Tighten all Fasteners.

Tightening Torque 8-10Nm / 5.9 ft lb - 7.38 ft lb. Take care when using a cordless driver.

Place M6 Nut Caps (Item 15) over all Nyloc Nuts.

2.3

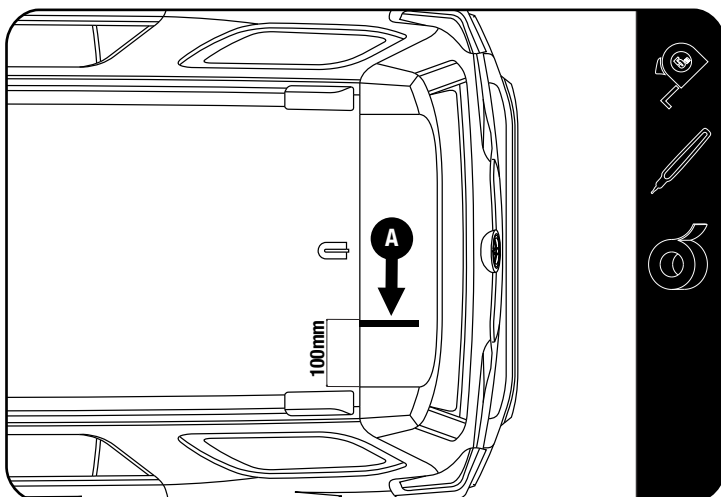

Measure 100mm from the inside edge of the spoiler trim, along the hatch edge and mark with masking tape (A) as shown.

2**FIT AND SECURE**

2.4

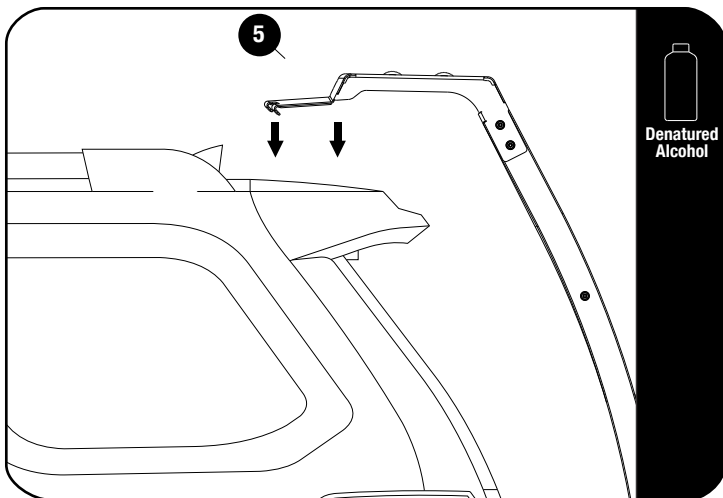

Clean the surface where the Top Mount Bracket (Item 5) will be secured with de-natured alcohol.

Hook the Ladder assembly from 2.1 and 2.2 over the Top Mount Bracket.

Position the Ladder assembly next to the masking tape.

2.5

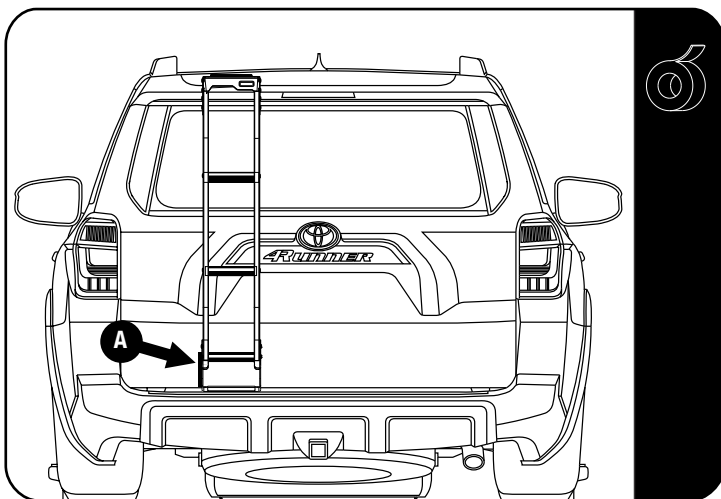

Making sure it is level, mark the Bottom position of the ladder with masking tape as shown (A).

Remove the Ladder assembly.

2.6

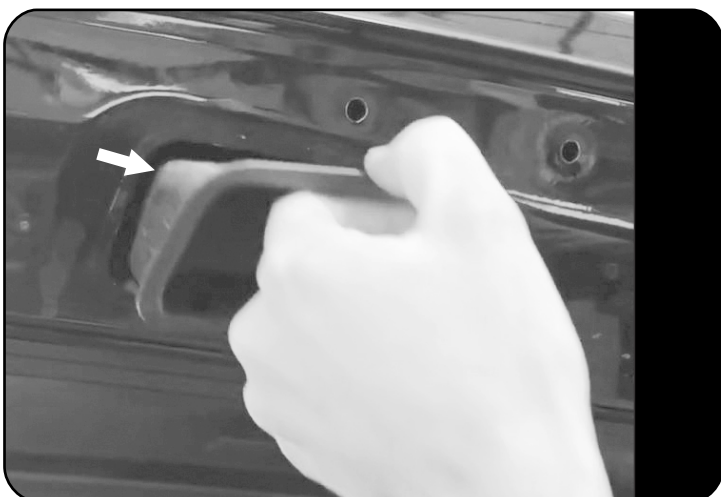

Open the Rear hatch and remove the left hand side handle as shown.

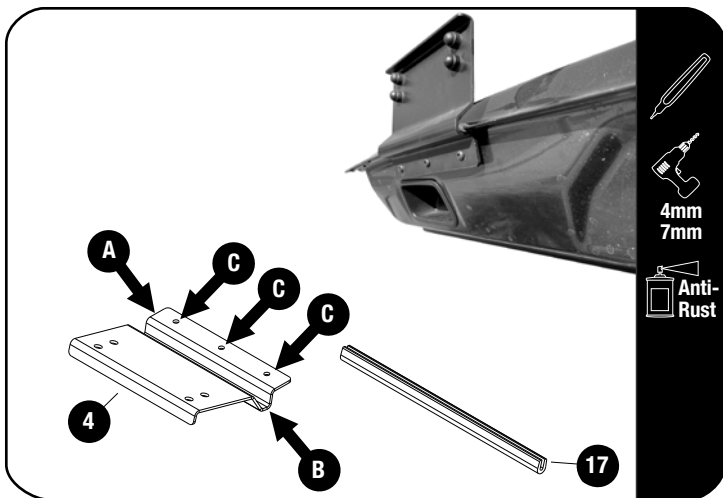
2**FIT AND SECURE****2.7**

Place the U-Channel Rubber (Item 17) over the Door Edge where the Bottom Clamp Bracket (Item 4) will be secured.

Align the left hand side (A) of the Bottom Clamp Bracket with the masking tape applied in 2.5 and press the bracket up against the door so the the door hatch sits in the slot (B).

Mark the hole centers (C) as shown. Drill a 4mm Pilot hole and open up to 7mm.

Apply Anti-Rust on drilled holes.

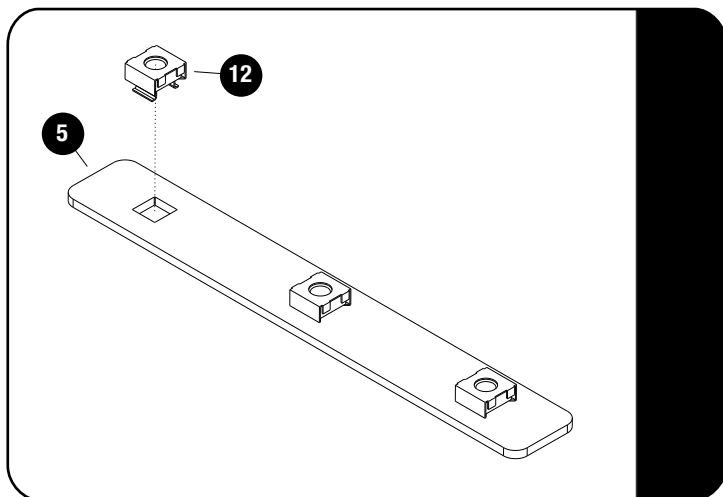
2.8

Assemble the M6 Cage Nuts (Item 14) to the Bottom Inner Plate (Item 7) as shown.

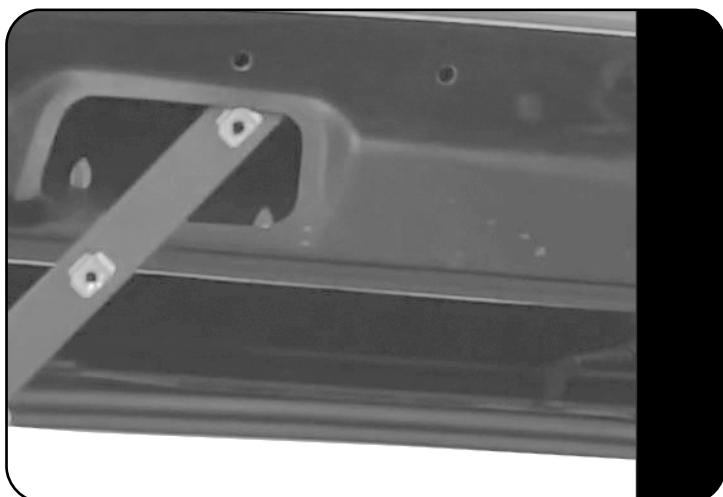
2.9

Slide the Bottom Inner Plate into the Door hatch as shown.

2

FIT AND SECURE

2.10

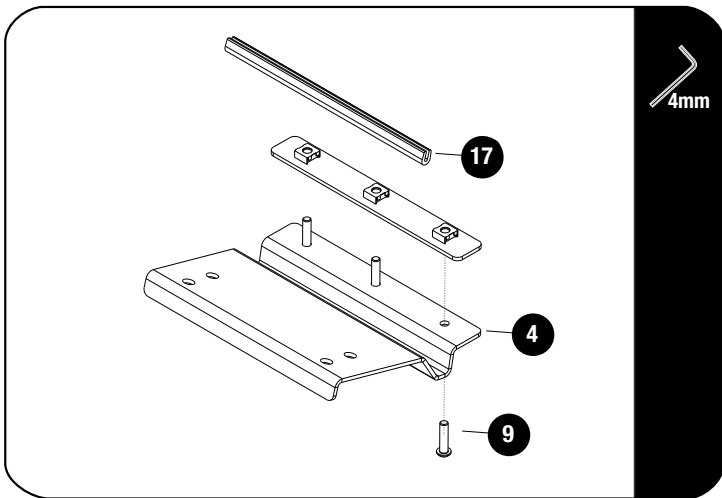

Secure the Bottom Clamp Plate (Item 4) to the Bottom Inner Plate (Item 5) using M6 x 25 Button Head Bolts.

Remove the backing tape of the self-adhesive tape on the Ladder Top Bracket (Item 1) and hook the Ladder Assembly over the top hatch edge, and align the ladder on the mark made earlier, take care not to let the adhesive tape touch the roof. Once aligned angle ladder down and firmly press the top down onto the tailgate top

2.11

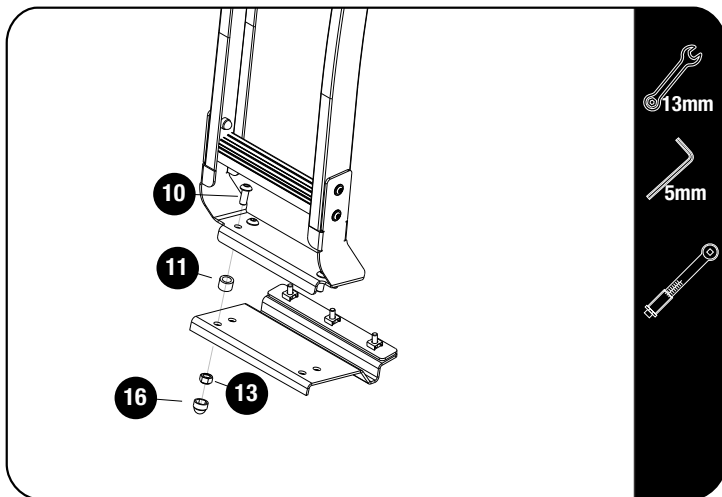

TIP: Start with the forward LH and RH fasteners, alternating between fasteners to pull the Ladder evenly.



Secure the Ladder assembly to the Bottom Mount Bracket (Item 4) as shown.

Use the M8 x 45 Button Head Bolt and Standard Nut (Items 18 & 19) in one of the back holes and start the clamping process, then use the M8 x 30 Button Head Bolts, M8 Nyloc Nuts and Aluminium Spacers (Items 10, 11 & 13) in the other three holes. Remove the M8 x 45 Button Head Bolt and standard Nut and replace them with the M8 x 30 Button Head Bolt.

Place M8 Nut Caps (Item 19) over M8 Nyloc Nuts (Item 19).



Tightening Torque:

M8 : 15-20Nm / 11.06 ft lb - 14.75 ft lb

3

FINISH

Congratulations! You did it. Take a step back and admire your work!

4

INSTALL OTHER VEHICLE AND RACK ACCESSORIES

Now's the time to visit your favorite Front Runner Dealer in person or online.

Be sure to tag us. We love to see our gear in action! #FrontRunnerOutfitters #BornToRoam

Share your adventures on: 