

# START HERE!

## READ ME FIRST

Don't be a hero and muscle through this installation without reading these fitting instructions first! Improper installation of this gear may void certain aspects of your warranty.

Before you begin, take a moment and open all your Front Runner rack kit boxes and gather the assembly instructions for the various components.

A complete kit will contain:

1. A Front Runner Mounting system specific to your vehicle
2. A Front Runner Rack Tray or Load bar Slats

This document will guide you through the assembly of the mounting system and assist you in fitting the roof rack tray or load bars to your specific vehicle.

Please refer to the next page for a list of all the components, quantities and tools required.

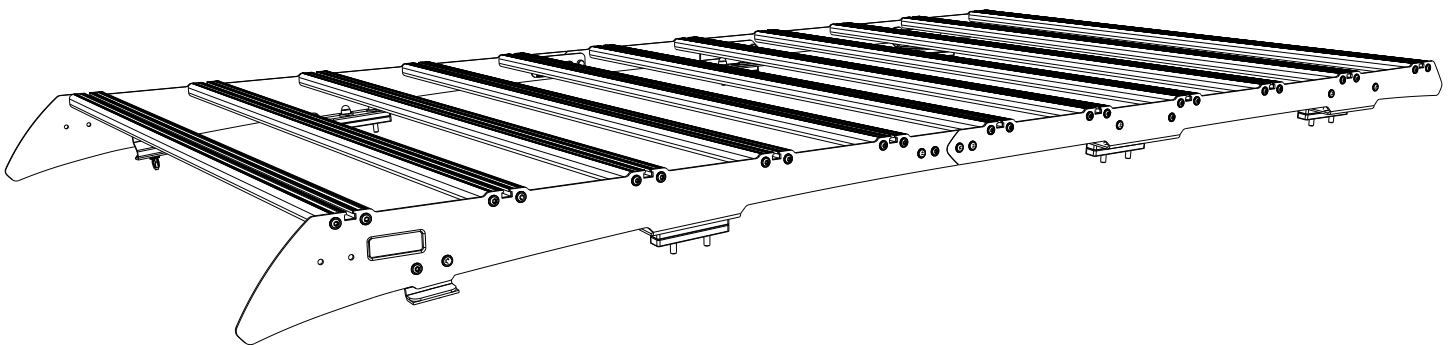

### IMPORTANT WARNING!

IT IS CRITICAL THAT ALL FRONT RUNNER PRODUCTS BE PROPERLY AND SECURELY ASSEMBLED AND ATTACHED TO YOUR VEHICLE. IMPROPER ATTACHMENT COULD RESULT IN AN AUTOMOBILE ACCIDENT, AND COULD CAUSE SERIOUS BODILY INJURY OR DEATH. YOU ARE RESPONSIBLE FOR ASSEMBLING AND SECURING ALL FRONT RUNNER PRODUCTS TO YOUR VEHICLE, CHECKING THE ATTACHMENTS PRIOR TO USE, AND PERIODICALLY INSPECTING THE PRODUCTS FOR ADJUSTMENT, WEAR AND DAMAGE. THEREFORE, YOU MUST READ AND UNDERSTAND ALL OF THE INSTRUCTIONS AND PRECAUTIONS SUPPLIED WITH YOUR FRONT RUNNER PRODUCT PRIOR TO INSTALLATION OR USE. IF YOU DO NOT UNDERSTAND ALL OF THE INSTRUCTIONS AND CAUTIONS, OR IF YOU HAVE NO MECHANICAL EXPERIENCE AND ARE NOT THOROUGHLY FAMILIAR WITH THE INSTALLATION PROCEDURES, YOU SHOULD HAVE THE PRODUCT INSTALLED BY A PROFESSIONAL INSTALLER OR OTHER QUALIFIED PERSONNEL.

**NOTE:** Front Runner will not be responsible for any damage caused by the failure to install the product according to these instructions.

Please call us if you have any questions about the installation of this product.



# 1 GET ORGANIZED

## IN THE BOX

1	2 X	Foot Rail Front LH & RH
2	2 X	Foot Rail Rear LH & RH
3	2 X	Joiner Plate
4	2 X	Front Support
5	2 X	Stiffener Plate 01 LH & RH
6	2 X	Stiffener Plate 02 LH & RH
7	12 X	M8 Nut Cap
8	12 X	M8 x 50 Hex Bolt
10	12 X	M8 x 25 x 2 Flat Washer
11	20 X	M6 Nyloc Nut
12	20 X	M6 Nut Cap
13	20 X	M6 x 16 Flange Button Head
14	44 X	M6 x 25 Thread Forming Screw
15	12 X	Plastic Spacer / 10mm
16	11 X	Slimsport Slat
17	6 X	Plastic Spacer / 6mm
18	2 X	Foot Spacer / 6mm

## TOOLS NEEDED

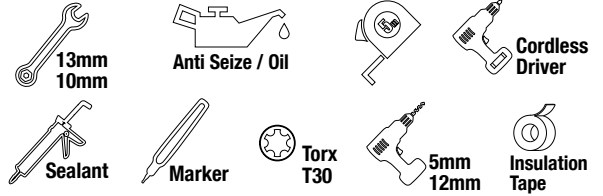
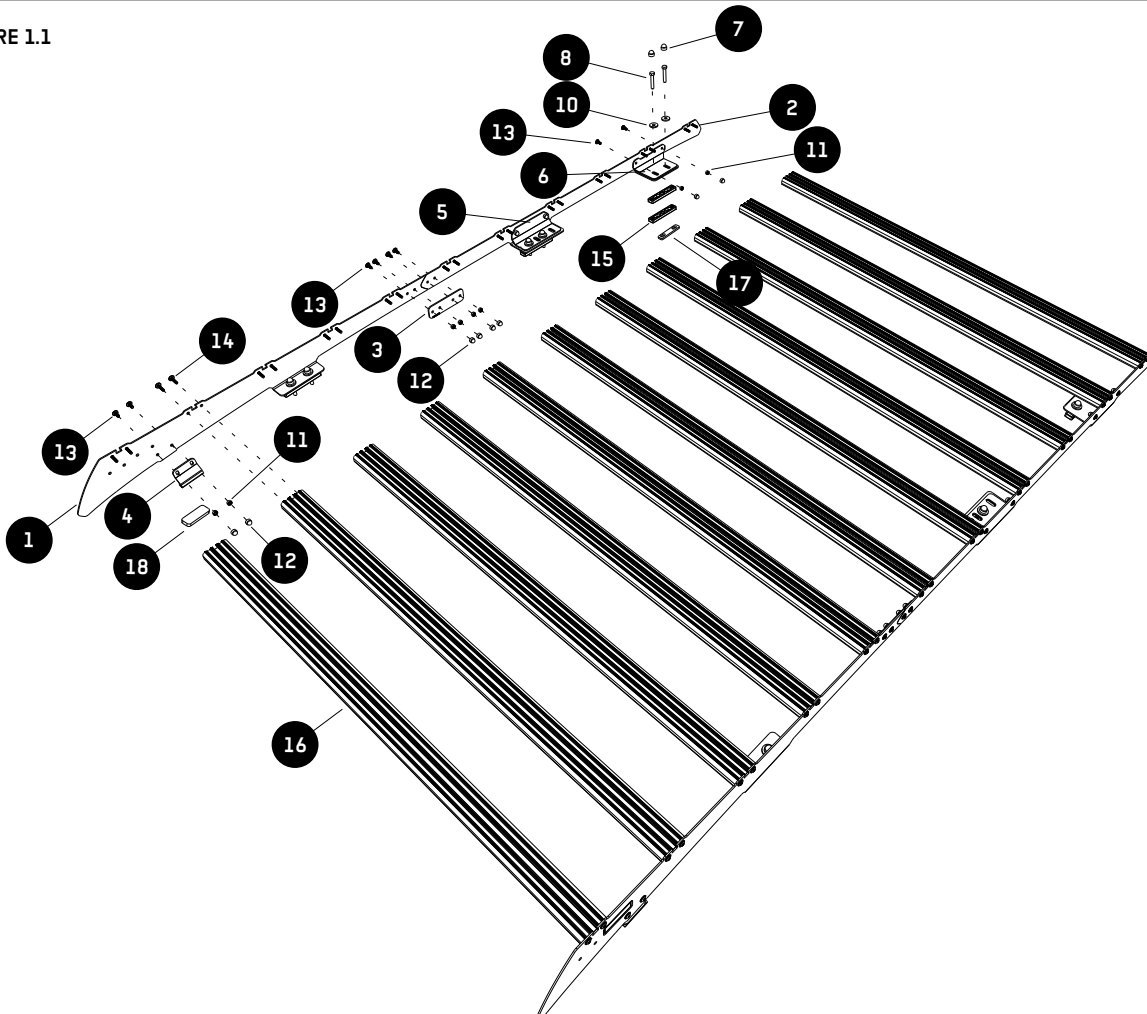

FIGURE 1.1



## 2

## ASSEMBLY

2.1

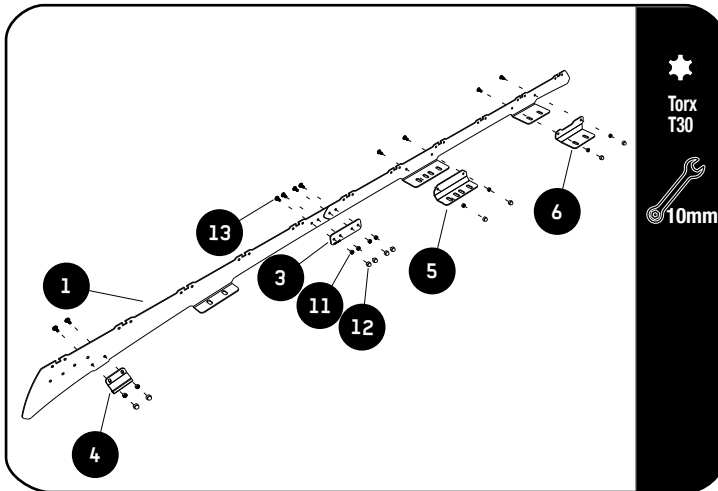

Secure the Joiner Plate (Item 3) to the Foot Rails (Items 1 & 2) as shown using M6 x 16 Flange Button Head Bolts and M6 Nyloc Nuts (Items 11 & 13).

Secure the Stiffener Plates (Items 5 & 6) to the Foot Rails (Items 1 & 2) using M6 x 16 Flange Button Head Bolts and M6 Nyloc Nuts (Items 11 & 13).

Loosely fit the Front Support (Items 4) to the Foot Rail (Item 1) using M6 x 16 Flange Button Head Bolts and M6 Nyloc Nuts (Items 11 & 13).

Do this to both LH & RH Foot Rails.

Place M6 Nut Caps (Item 12) over all Nyloc Nuts.

2.2

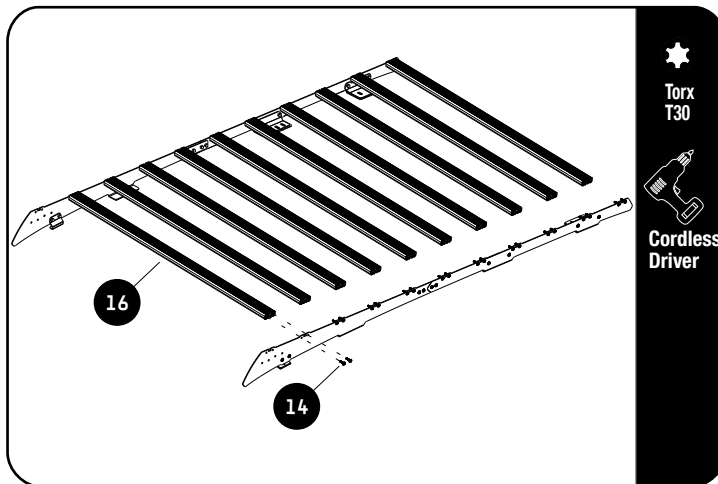

Fit 10 Slimsport Slats (Item 16) to assembly 2.1 using M6 x 25 Thread Forming Screws (Item 14).



Note do not fit front slat.



Apply a little Anti Seize / oil on screw threads before inserting. Note these are thread forming screws.



Tightening Torque 8-10Nm / 5.9 ft lb - 7.38 ft lb. Take care when using a cordless driver.

## 3

## PREPERATION

3.1

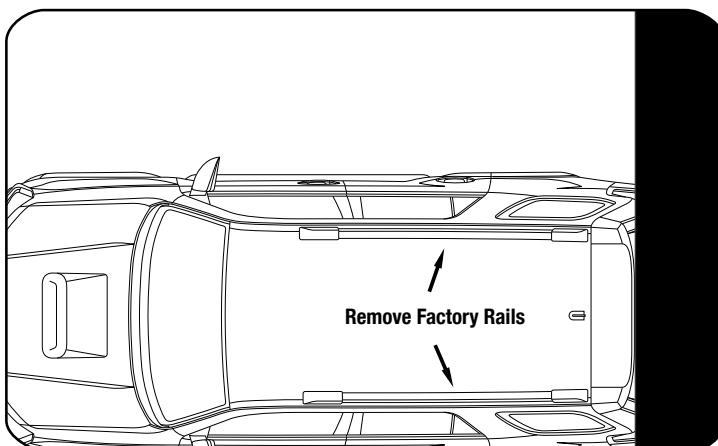

Remove both factory rails from the vehicles roof.

**3**

**PREPERATION**

**3.2**

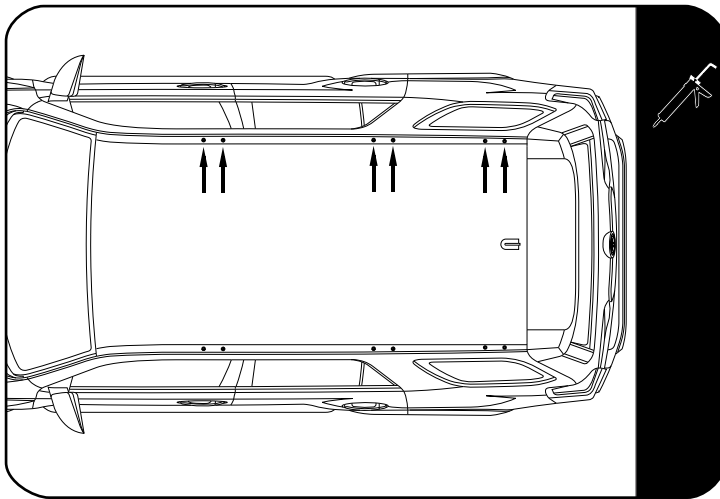

Clean the ditch before placing silicone into and around each of the fixing points.  
 Use denatured alchohol and ensure the ditch is clean from any residue where the Support Plate 01 (Item 3) will be resting on the ditch.  
 Place 2x 10mm Spacers and 1x 6mm Spacer (Items 15 & 17) into each of the mounting positions. See 3.4.

**3.3**

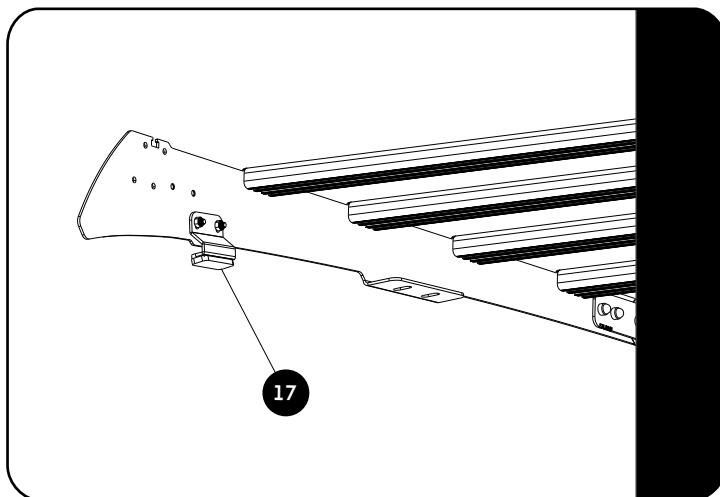

Remove the backing from the double sided tape on the bottom of the Support Plate (Item 4) before applying the Spacer (Item 17) to the Support Plate.  
 Remove the backing from the double sided tape on the bottom of the Spacer before placing the rack on the vehicle.

**3.4**

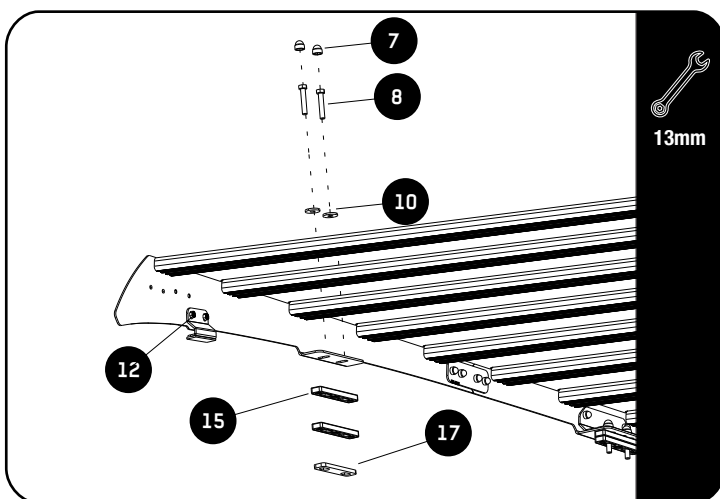

Place a bead of silicone down the length of each M8 x 50 Hex Bolts (Item 8) before inserting.  
 Secure the rack using M8 x 50 Hex Bolts and M8 x 25 x 2 Flat Washers (Items 8 & 10).  
 Ensure that the Support Plate is fully seated on the ditch mold before tightening.  
 Fully tighten all fasteners.  
 Place M6 and M8 Nut Caps (Items 7 & 12) over all Hex Bolts.

4.1

**STANDARD WIND FAIRING ASSEMBLY**

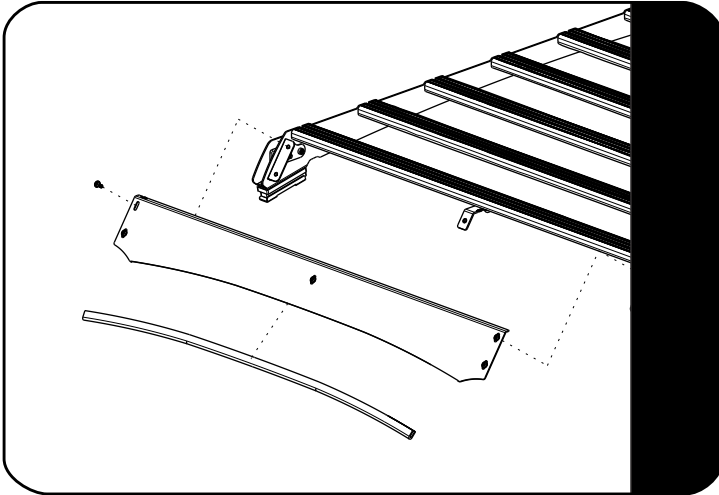

Refer to fitment guide RRAC274

4.2

**LIGHT BAR WIND FAIRING ASSEMBLY**

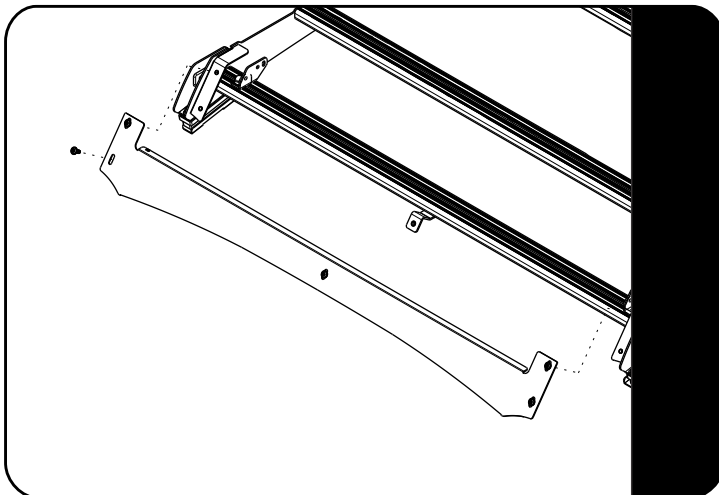

Refer to fitment guide RRAC76

5

## COMPLETION

5.1

Congratulations! You did it. Take a step back and admire your work!



6

## INSTALL OTHER VEHICLE AND RACK ACCESSORIES

Now's the time to visit your favorite Front Runner dealer in person or online.

### IMPORTANT!

FRONT RUNNER RACK KITS OFTEN HAVE A HIGHER LOAD RATING THAN THE VEHICLES THEY ARE MOUNTED TO. PLEASE REFER TO YOUR SPECIFIC VEHICLE MANUFACTURER FOR A RECOMMENDED ROOF RATING. FRONT RUNNER CANNOT BE RESPONSIBLE FOR IMPROPER LOADING BEYOND THE VEHICLE MANUFACTURER'S STATED LOAD CAPACITY.

Be sure to tag us. We love to see our gear in action! #FrontRunnerOutfitters #BornToRoam

Share your adventures on: 