

PRINSU ROOF RACK INSTALLATION GUIDE



FJ CRUISER

All products built and designed by Prinsu Design Studio are intended for off-road use and should be assembled, installed, and used according to Prinsu Design Studio's recommendations. Prinsu Design Studio products should be used safely with good judgment towards others and the environment. By installing Prinsu Design Studio Products on your vehicle you assume all liability. Prinsu Design Studio will not be held liable for damages or loss associated with the installation or use of its products. Be smart, use good judgement, don't overload your vehicle to the point of inferior handling and maneuverability!

PRINSU ROOF RACK INSTALLATION GUIDE

CROSSBAR HARDWARE DIAGRAM

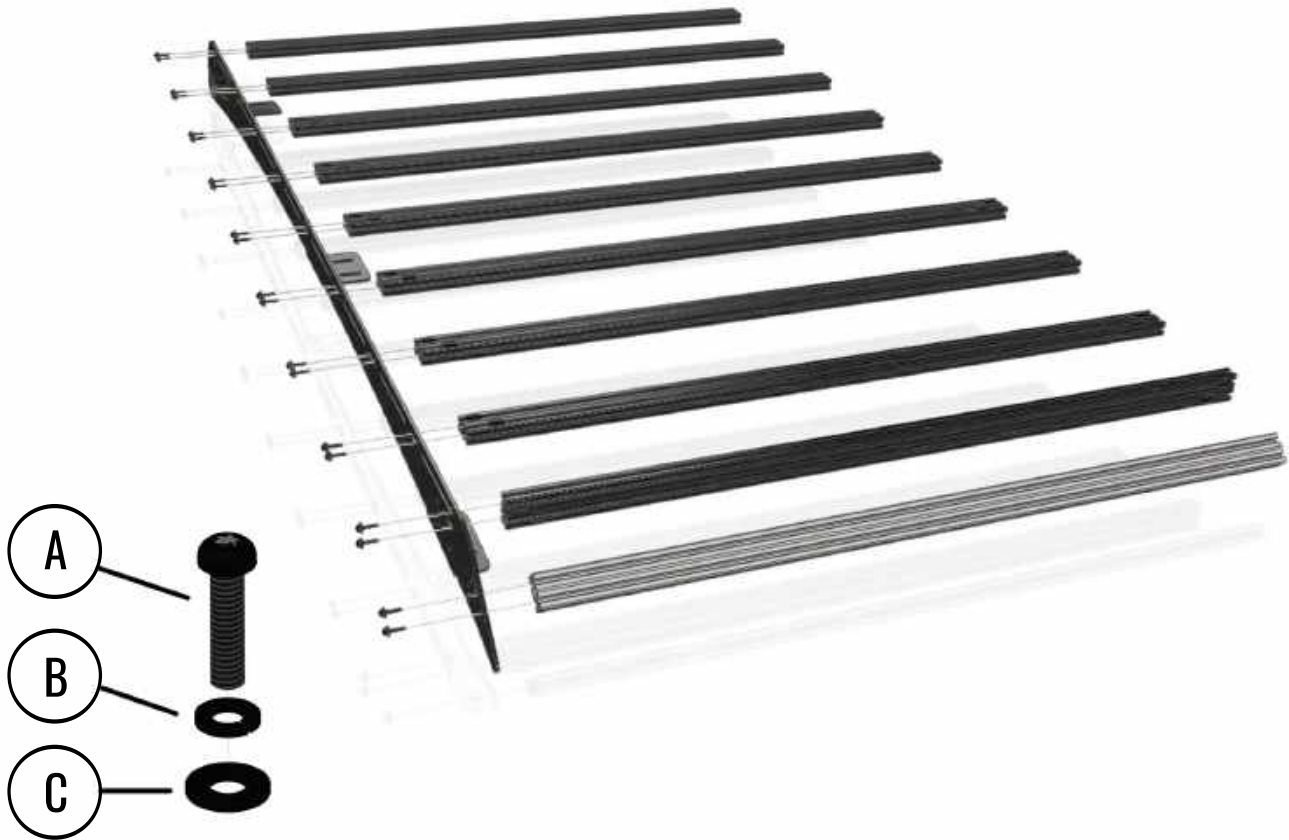

	PART	QUANTITY
A	1/4" - 20 x 1" MACHINE SCREW	40
B	1/4" LOCK WASHER	40
C	1/4" FLAT WASHER	40

All products built and designed by Prinsu Design Studio are intended for off-road use and should be assembled, installed, and used according to Prinsu Design Studio's recommendations. Prinsu Design Studio products should be used safely with good judgment towards others and the environment. By installing Prinsu Design Studio Products on your vehicle you assume all liability. Prinsu Design Studio will not be held liable for damages or loss associated with the installation or use of its products. Be smart, use good judgement, don't overload your vehicle to the point of inferior handling and maneuverability!

PRINSU ROOF RACK INSTALLATION GUIDE

WIND DEFLECTOR HARDWARE DIAGRAM

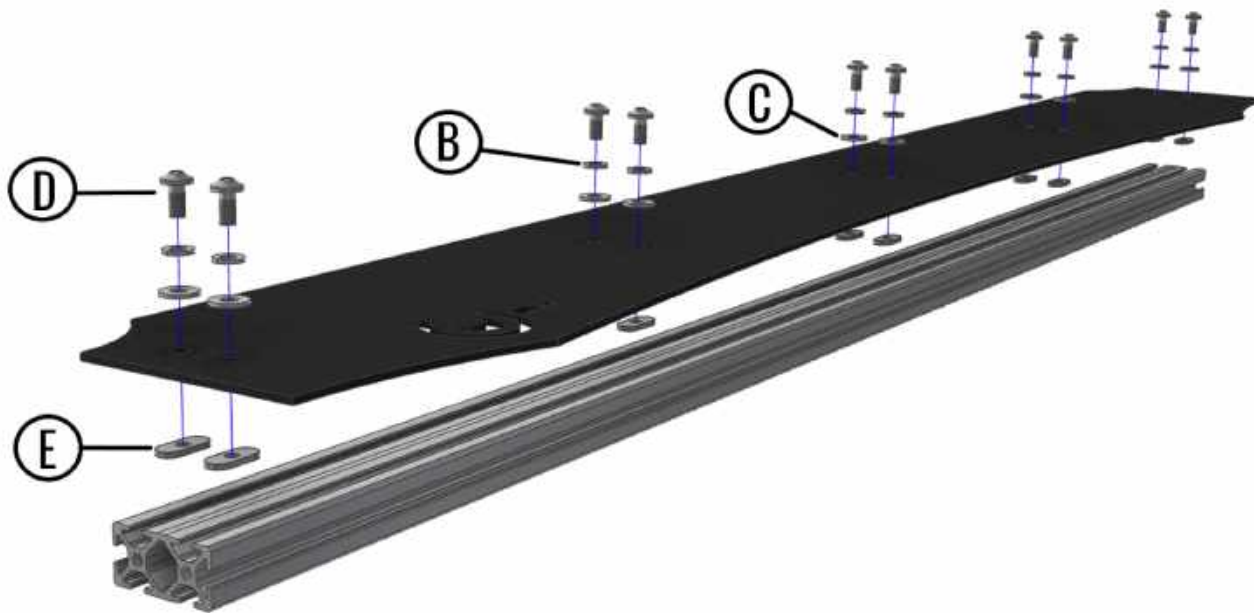

PART	DESCRIPTION	QUANTITY
B	1/4" LOCK WASHER	10
C	1/4" FLAT WASHER	10
D	1/4" - 20 x 1/2" PAN HEAD SCREW	10
E	1/4" - 20, 10 SERIES T-NUT	10

All products built and designed by Prinsu Design Studio are intended for off-road use and should be assembled, installed, and used according to Prinsu Design Studio's recommendations. Prinsu Design Studio products should be used safely with good judgment towards others and the environment. By installing Prinsu Design Studio Products on your vehicle you assume all liability. Prinsu Design Studio will not be held liable for damages or loss associated with the installation or use of its products. Be smart, use good judgement, don't overload your vehicle to the point of inferior handling and maneuverability!

PRINSU ROOF RACK INSTALLATION GUIDE

MOUNTING HARDWARE DIAGRAM

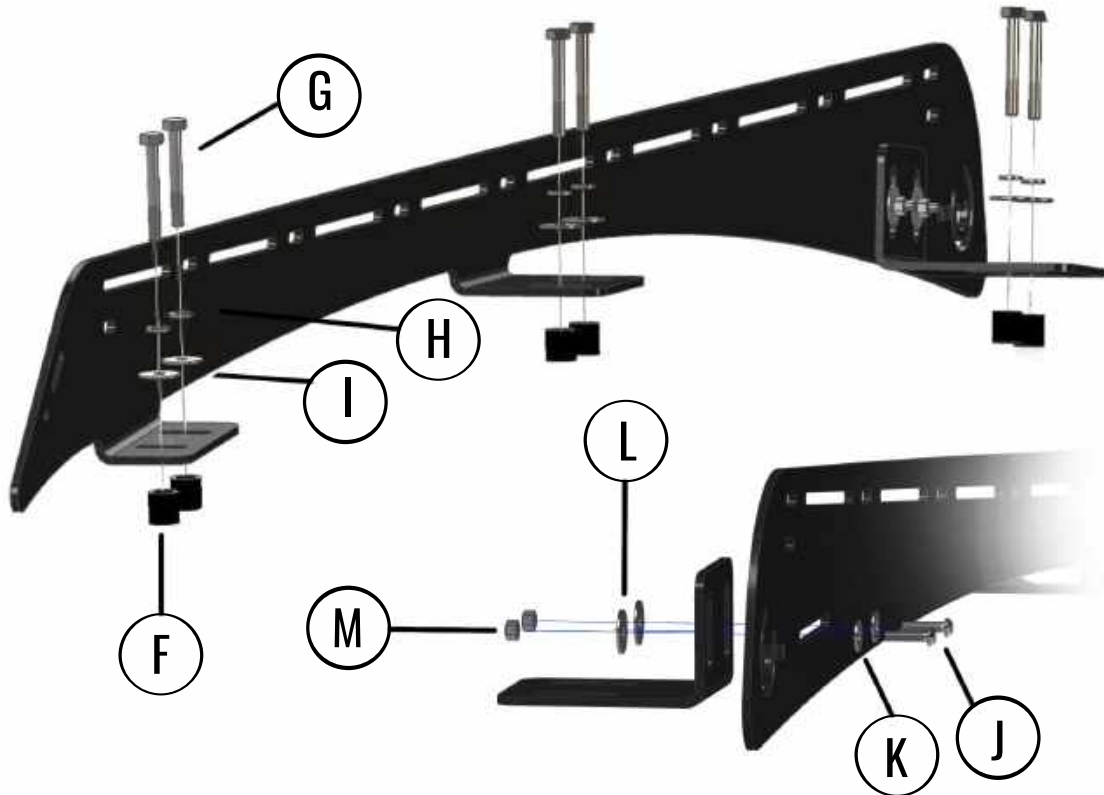

	PART	QUANTITY
F	3/4" x .509" x 3/4" LONG SPACER (OD X ID X LENGTH)	12
G	M8 - 1.25 X 60MM HEX CAP SCREW	12
H	5/16" LOCK WASHER	12
I	5/16" FENDER WASHER	12
J	1/4" - 20 x 1" BUTTON HEAD SCREW	4
K	1/4" SAE FLAT WASHER	4
L	1/4" X 1" FENDER WASHER	4
M	1/4" - 20 LOCK NUT	4

All products built and designed by Prinsu Design Studio are intended for off-road use and should be assembled, installed, and used according to Prinsu Design Studio's recommendations. Prinsu Design Studio products should be used safely with good judgment towards others and the environment. By installing Prinsu Design Studio Products on your vehicle you assume all liability. Prinsu Design Studio will not be held liable for damages or loss associated with the installation or use of its products. Be smart, use good judgement, don't overload your vehicle to the point of inferior handling and maneuverability!

PRINSU ROOF RACK INSTALLATION GUIDE

WIND DEFLECTOR ATTACHMENT

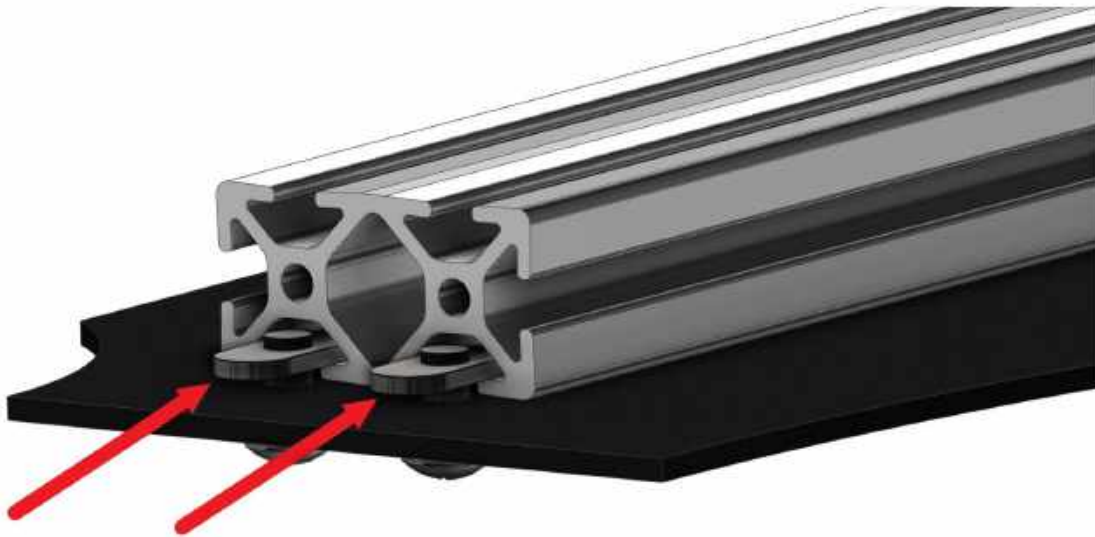

STEPS

1. INSTALL THE WIND DEFLECTOR HARDWARE AS SHOWN IN THE DIAGRAM ON PAGE 3. THREAD THE SCREWS JUST BARELY INTO THE T-NUTS TO BEGIN WITH.
2. LAY THE WIND DEFLECTOR ON A FLAT SURFACE IN THE ORIENTATION SHOWN ABOVE.
3. FROM ONE END START SLIDING THE EXTRUSION BAR SO THAT THE T-NUTS FEED INTO THE CHANNEL.
4. ONCE EVERYTHING IS LINED UP PROPERLY THEY WILL SLIDE RIGHT TOGETHER.
5. NOW WITH ALL THE T-NUTS FED INTO THE CHANNEL AND THE EXTRUSION BAR AND WIND DEFLECTOR LINED UP FLUSH AT BOTH ENDS, TURN THE ASSEMBLY OVER AND TIGHTEN THE SCREWS UNTIL THE LOCK WASHERS ARE FULLY COMPRESSED.
- 6 . THE WIND DEFLECTOR ASSEMBLY CAN NOW BE BOLTED TO THE ROOF RACK.

All products built and designed by Prinsu Design Studio are intended for off-road use and should be assembled, installed, and used according to Prinsu Design Studio's recommendations. Prinsu Design Studio products should be used safely with good judgment towards others and the environment. By installing Prinsu Design Studio Products on your vehicle you assume all liability. Prinsu Design Studio will not be held liable for damages or loss associated with the installation or use of its products. Be smart, use good judgement, don't overload your vehicle to the point of inferior handling and maneuverability!

PRINSU ROOF RACK INSTALLATION GUIDE

ROOF RACK INSTALLATION INSTRUCTIONS

***If you do not feel comfortable with the process outlined in this manual please seek professional installation assistance**

***Please read all instruction prior to beginning installation. Various steps may relate directly to previous or future parts of the installation process. Prinsu Design Studio is not liable for damages caused to your vehicle during the installation process**



Begin by removing the stock roof rack



There are six torx bolts per side that will need removed



Now pre assemble the roof rack as shown in the previous pages. Do not install the rear mounting feet yet though



Apply a generous amount of silicon to the holes as shown above



Next place the spacers on the roof

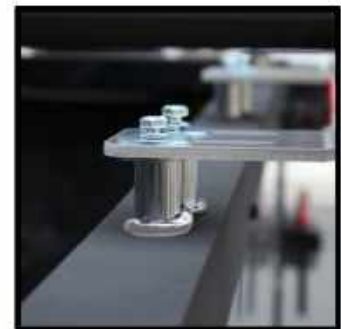

Now place the roof rack on the vehicle and loosely tighten the front four bolts on both sides

All products built and designed by Prinsu Design Studio are intended for off-road use and should be assembled, installed, and used according to Prinsu Design Studio's recommendations. Prinsu Design Studio products should be used safely with good judgment towards others and the environment. By installing Prinsu Design Studio Products on your vehicle you assume all liability. Prinsu Design Studio will not be held liable for damages or loss associated with the installation or use of its products. Be smart, use good judgement, don't overload your vehicle to the point of inferior handling and maneuverability!

PRINSU ROOF RACK INSTALLATION GUIDE

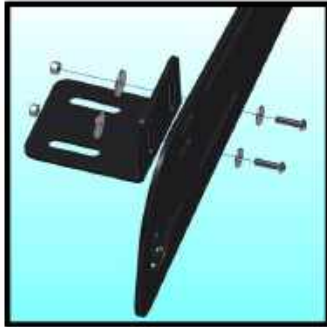

Now attach the rear mounting feet with the hardware in the order shown above



Again only loosely tighten at this point



loosely tighten the bottom bolts into the roof. The hardware attaching the rear mounting feet to the side rail can be fully tightened now



Ensure the roof rack is sitting squarely on the roof then full tighten down all remaining bolts



Double Check all fasteners to ensure they are properly tightened before your first drive ...



... and then periodically there after to ensure your roof rack remains fully functional and secure

The Installation is now complete, enjoy your new Prinsu roof rack!

All products built and designed by Prinsu Design Studio are intended for off-road use and should be assembled, installed, and used according to Prinsu Design Studio's recommendations. Prinsu Design Studio products should be used safely with good judgment towards others and the environment. By installing Prinsu Design Studio Products on your vehicle you assume all liability. Prinsu Design Studio will not be held liable for damages or loss associated with the installation or use of its products. Be smart, use good judgement, don't overload your vehicle to the point of inferior handling and maneuverability!

PRINSU ROOF RACK INSTALLATION GUIDE

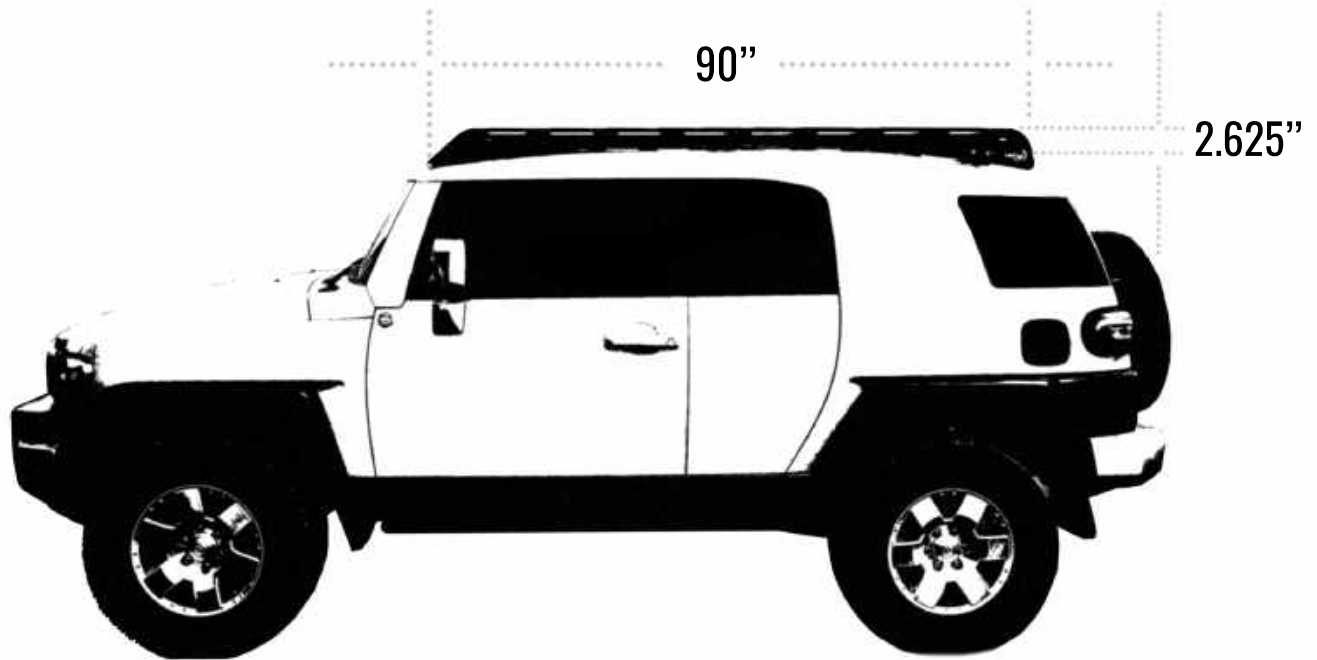

FEATURE	MEASUREMENT/QUANTITY
OVERALL LENGTH	90"
SIDE RAIL HEIGHT*	2.625"
WEIGHT	-58 LBS
50" CROSS BARS - BLACK - (1X2)	9
50" CROSS BAR - CLEAR - (1X2)	1

*AS MEASURED AT THE CENTER OF THE SIDE RAIL

All products built and designed by Prinsu Design Studio are intended for off-road use and should be assembled, installed, and used according to Prinsu Design Studio's recommendations. Prinsu Design Studio products should be used safely with good judgment towards others and the environment. By installing Prinsu Design Studio Products on your vehicle you assume all liability. Prinsu Design Studio will not be held liable for damages or loss associated with the installation or use of its products. Be smart, use good judgement, don't overload your vehicle to the point of inferior handling and maneuverability!

PRINSU ROOF RACK INSTALLATION GUIDE

WARRANTY

PRINSU DESIGN STUDIO will warranty all PRINSU DESIGN STUDIO manufactured parts for a LIFETIME of use. This limited Lifetime Warranty is effective for as long as the original retail purchaser owns the product. This warranty terminates when the original retail purchaser sells or otherwise transfers the product to any other person. Each manufactured product must be installed following PRINSU DESIGN STUDIO'S recommended fitment and installation procedures. Any customization or modification to the original product design, functionality, or use, either by said customer or by PRINSU DESIGN STUDIO voids all warranty eligibility. It is the sole discretion of CBI Offroad to determine warranty eligibility. Subject to the limitations and exclusions described in this warranty, PRINSU DESIGN STUDIO will remedy defects in materials or workmanship by repairing or replacing, at its option, a defective product without charge for parts. In addition, PRINSU DESIGN STUDIO may elect, at its option, not to repair or replace a defective product but rather issue to a purchaser a refund equal to the purchase price paid for the product or a credit to be used toward the purchase of a new PRINSU DESIGN STUDIO product. No warranty is given for defects caused by normal wear and tear, cosmetic rust scratches, accidents, unlawful vehicle operation, products used for racing or competition, or modification of, or any types of repair of, a PRINSU DESIGN STUDIO manufactured product. The PRINSU DESIGN STUDIO Warranty does not include the powder coated finish. No warranty is given for defects resulting from conditions beyond PRINSU DESIGN STUDIO'S control including, but not limited to, misuse, neglect, overloading, improperly maintained or failure to assemble, mount or use the product in accordance with PRINSU DESIGN STUDIO'S written instructions or guidelines included with the product or implied use made available to the purchaser.

DISCLAIMER OF LIABILITY REPAIR OR REPLACEMENT OF A DEFECTIVE PRODUCT OR THE ISSUANCE OF A REFUND OR CREDIT (AS DETERMINED BY PRINSU DESIGN STUDIO) IS A PURCHASER'S EXCLUSIVE REMEDY UNDER THIS WARRANTY. DAMAGE TO A PURCHASER'S VEHICLE, CARGO AND/OR TO ANY OTHER PERSON OR PROPERTY IS EXCLUDED. THIS WARRANTY IS EXPRESSLY MADE IN LIEU OF ANY AND ALL OTHER WARRANTIES, EXPRESS OR IMPLIED, INCLUDING THE WARRANTIES OF MERCHANTABILITY AND FITNESS FOR A PARTICULAR PURPOSE. PRINSU DESIGN STUDIO'S SOLE LIABILITY TO ANY PURCHASER IS LIMITED TO THE REMEDY SET FORTH ABOVE. IN NO EVENT WILL PRINSU DESIGN STUDIO BE LIABLE FOR ANY LOST PROFITS, LOST SALES, OR FOR ANY CONSEQUENTIAL, DIRECT, INDIRECT, INCIDENTAL, SPECIAL, EXEMPLARY, OR PUNITIVE DAMAGES OR FOR ANY OTHER DAMAGES OF ANY KIND OR NATURE