



**FRONT RUNNER**

**6 CUB PACK DRAWER**

**ENG**

SSAM014



**INSTALL TIME: 45 mins**

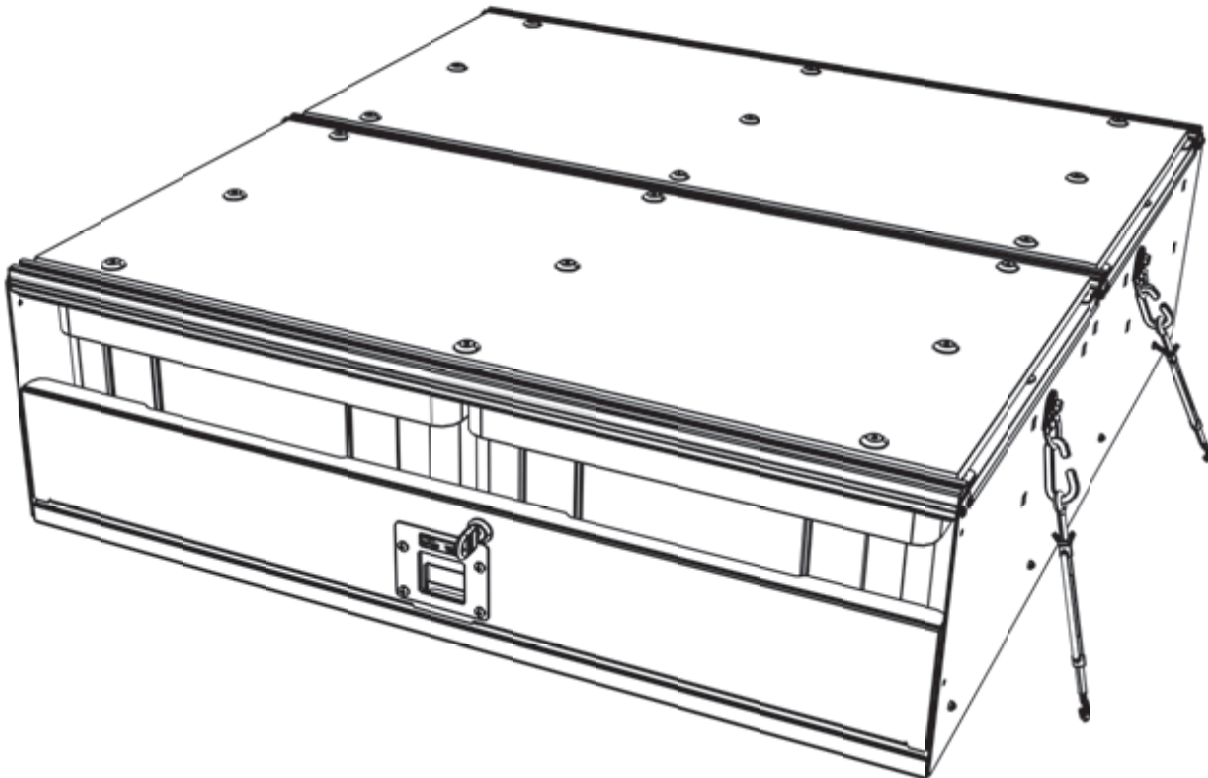

### **IMPORTANT WARNING!**

**IT IS CRITICAL THAT ALL FRONT RUNNER PRODUCTS BE PROPERLY AND SECURELY ASSEMBLED AND ATTACHED TO YOUR VEHICLE. IMPROPER ATTACHMENT COULD RESULT IN AN AUTOMOBILE ACCIDENT, AND COULD CAUSE SERIOUS BODILY INJURY OR DEATH TO YOU OR TO OTHERS. YOU ARE RESPONSIBLE FOR ASSEMBLING AND SECURING ALL FRONT RUNNER PRODUCTS TO YOUR VEHICLE, CHECKING THE ATTACHMENTS PRIOR TO USE, AND PERIODICALLY INSPECTING THE PRODUCTS FOR ADJUSTMENT, WEAR, AND DAMAGE. THEREFORE, YOU MUST READ AND UNDERSTAND ALL OF THE INSTRUCTIONS AND CAUTIONS SUPPLIED WITH YOUR FRONT RUNNER PRODUCT PRIOR TO INSTALLATION OR USE. IF YOU DO NOT UNDERSTAND ALL OF THE INSTRUCTIONS AND CAUTIONS, OR IF YOU HAVE NO MECHANICAL EXPERIENCE AND ARE NOT THOROUGHLY FAMILIAR WITH THE INSTALLATION PROCEDURES, YOU SHOULD HAVE THE PRODUCT INSTALLED BY A PROFESSIONAL INSTALLER OR OTHER QUALIFIED PERSONNEL.**

# 1 GET ORGANIZED...

Here is what you are looking at for SSAM014:

Item #	Quantity	Description
1	1	DRAWER SYSTEM
2	4	60mm CARABINER
3	6	M6 STUD PLATE
4	4	M8 D-RING
5	4	TURNBUCKLE
6	4	M6 NYLOC HEX NUT
7	4	M6 SPRING WASHER
8	4	M6 CLINCH NUT
9	4	M6X35 HEX BOLT
10	4	M6 WING NUT
11	8	M6X19 FLAT WASHER
12	6	M6 NYLON FLAT WASHER
13	6	M6 EYE NUT

**You will need:**

- 10 mm Flat or Socket Wrench
- 4, 6 and 9mm Drill bits
- White Marker / Chalk
- Permanent Black Marker
- Utility Knife
- Tape Measure
- Drilling Machine
- Clinch Nut Crimping Tool
- A Friend

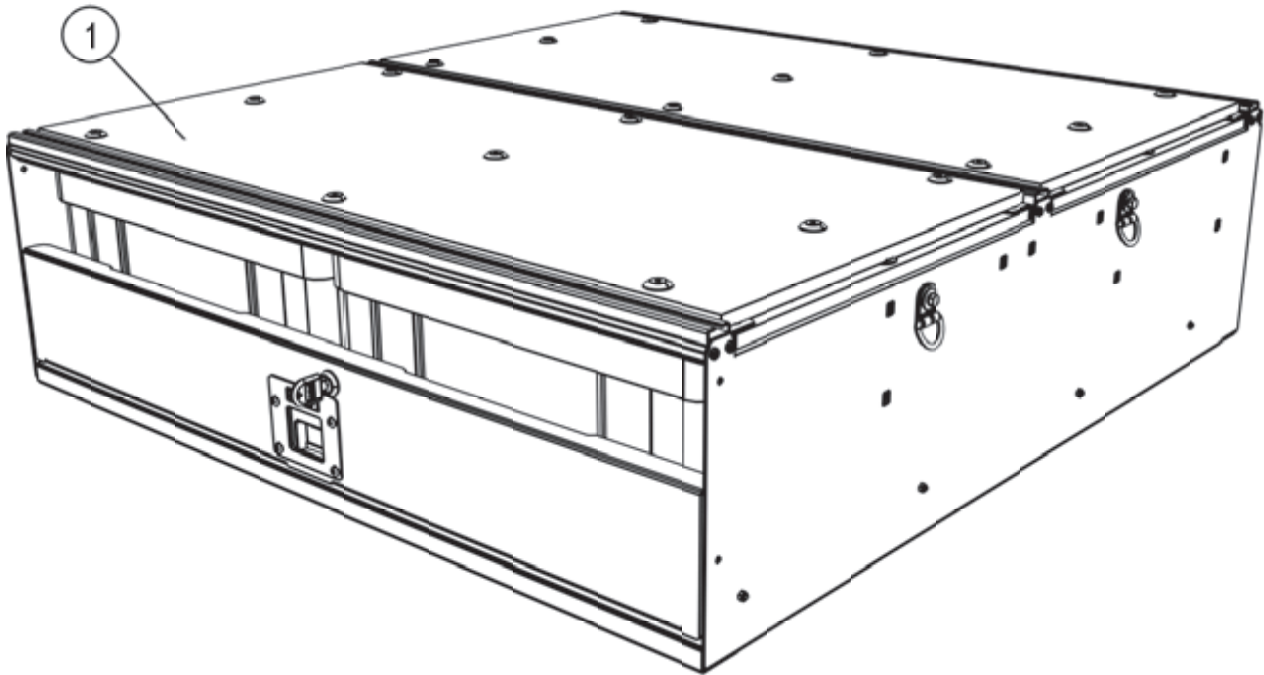

## 2 FIT DRAWER SYSTEM

**(A)** Remove the Rear Jump seats if fitted as per your vehicles owner's manual.

**(B)** In the picture to the right, the SUV has Factory Fitted D-Rings these will be used to secure the Drawer System. If your vehicle does not have Factory Fitted D-Rings move on to Step2H which shows how to install your own fixing points.

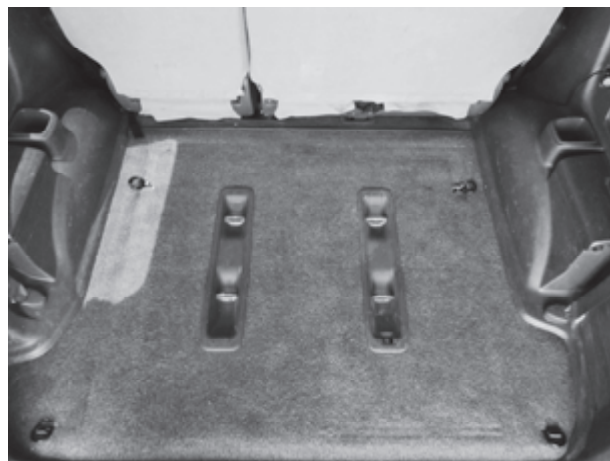

**(C)** To check if your vehicle has the appropriate fixing points, place the Drawer System in the vehicle. Make sure you can close the door or hatch without the Drawer system touching the door or hatch. To prevent this from happening set the drawer system as deep into the trunk as possible. Close the door or hatch gently. From the inside of the vehicle, lean over the rear seats and adjust the drawer system so that it is plus minus 2cm away from the door or hatch. Open the back of the vehicle again. Check that the Drawer is centred in the vehicle using a measuring tape.

With the Drawer in position check that the Factory Fitted D-rings are positioned in line with D-Rings on the Drawer system as indicated by the arrows, and that nothing will interfere with the Turn-Buckle.

If you find that your vehicle does not have mounting points in the appropriate positions move on to Steps2D.

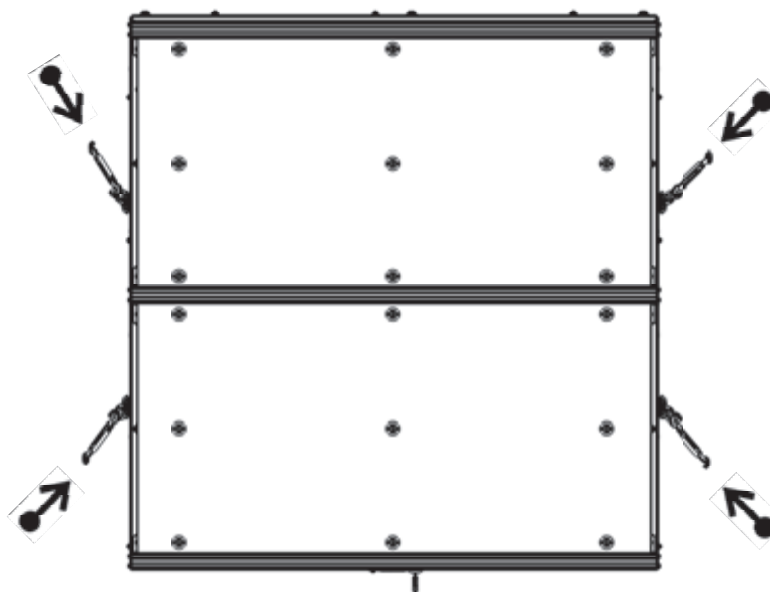

## **2** FIT DRAWER SYSTEM CONT...

- ( D )** With the Drawer still in place from Step2C, mark the mounting points with a piece of chalk on the carpet or a permanent marker on the body work. Note: They should be angled away from each other as shown in Step2C.

Lift up the Carpet and check that the points you have chosen are not partially on a ridge. If they are, move the point so that when you mount a D-Ring (Item 4) it will be on a flat surface with no immediate obstructions.

- ( E )** Another point to keep in mind is, will you be able to access the desired point from underneath the vehicle (Yes or No)? If Yes move on to Step2F, If No move on to Step2G.

- ( F )** Once you are happy with the positions of the D-Rings Remove the Drawer System from the vehicle. Lift the carpet up and Drill a 4mm Pilot hole through the floor of the vehicle at each mounting point.

Open the pilot hole with a 6mm drill bit. Place a D-Ring over each hole, then use a M6x14 Flat washer and M6x35 Hex Bolt to hold in place. Have your Friend hold the Hex Bolts in place while you secure the Hex Bolt with another M6x19 flat washer and a M6 Nyloc Hex Nut from under the vehicle. Position the D-Rings in line with the Drawer system's D-Rings. Tighten fully with two 10mm Wrenches.

- ( G )** Open the 4mm pilot hole with a 9mm drill bit. Insert Clinch Nut (Item 8) and crimp. Place a D-Ring over the holes in the clinch nuts. Use the M6x19 Flat washers and M6 Spring Washers with the M6x35 Hex Bolts. Secure the D-Rings into place using a 10mm Wrench.

- ( H )** Lay the carpet back down. Press hard and feel for the D-Ring. Mark the bolt head and the ridge of the D-Ring just in front of the bolt head. With a Craft Knife cut the carpet on that line. Now push the D-Ring through the cut.

Place the Drawer System back into the Vehicle as Described in Step2C.

## 2 FIT DRAWER SYSTEM CONT...

- ( I )** Take the Turn-buckles (Item 5) and loosen the round end of the four Turnbuckles. Screw a M6 Wing Nut (Item 10) onto each round end. Reassemble the Turn-buckle as shown below.

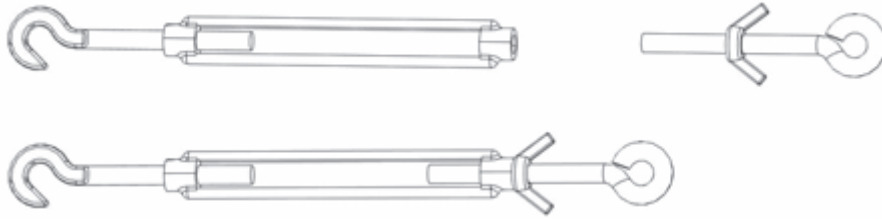

- ( J )** Hook a Carabiner (Item 2) onto one of the Drawer Systems D-Rings then hook the "ring" end of the Turn-buckle into the Carabiner (Item 5). At this point you will see how far you need to extend the Turn-buckle to reach the closest D-Ring on your vehicle. Once adjusted hook the Turn-buckle onto the D-Ring and loosely tighten. Repeat this three more times. With all four points attached tighten the Turn-buckles. But do not over tighten, as this may cause the Drawer System to bow out of shape.

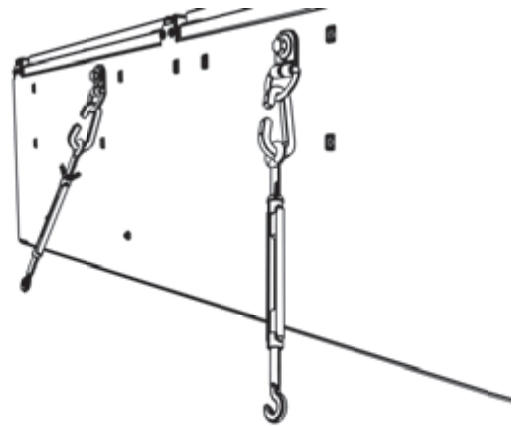

- ( K )** Check that the drawer opens and closes smoothly without having to force it. If you have to force the Drawer to close or open, loosen the Turn-buckles slightly. Check again. If satisfied tighten the Wing Nut firmly as shown below by the arrow. This will prevent the Turn-buckle from loosening over time.



- ( L )** Congratulations, Take a step back and admire your handy work. Good Job!

