

# TROLLEY GHF 500K

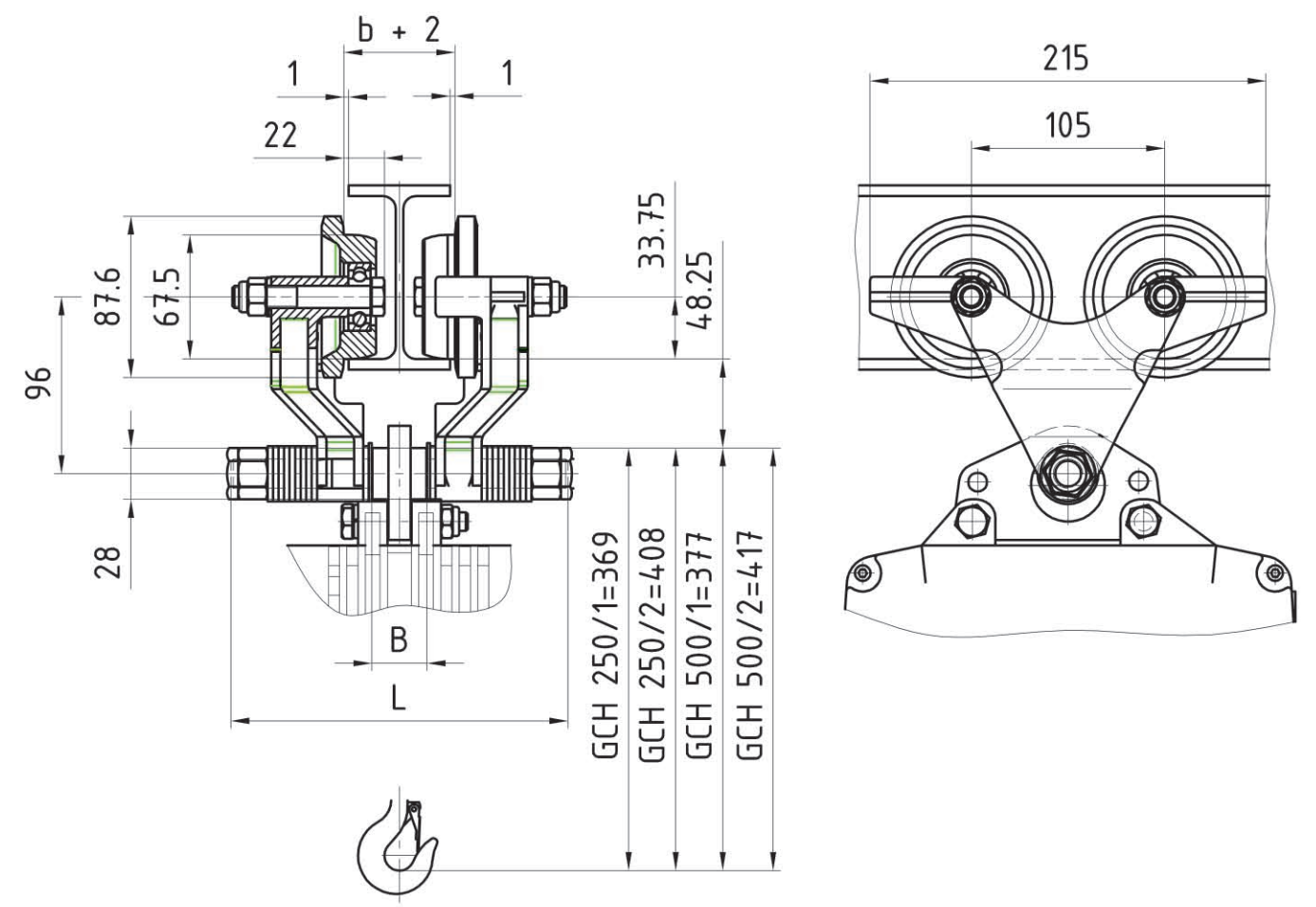

Triebwerksgruppe FEM classification Groupe FEM	1Bm	1Am	2m	3m	4m	Tragbolzen Nr. Spindle No. Axe No.	1	Max. Flanschdicke Flange thickness max. Epaisseur d'aile max.	X= 24 mm
	[kg]	[kg]	[kg]	[kg]	[kg]	Flanschbreite [mm] Width of flange [mm] Largeur d'aile [mm]	50-99	Kleinste Flanschbreite Min. flange width Largeur d'aile min.	50 mm
GHF 500 K	500	500	500	400	320	D [mm]	ø28	Gewicht Weight Poids	2.5 kg
						B [mm]	30		
						L [mm]	183		
						Anz. Hülsen * Länge No. of tubes * length No. de douilles * long.	-		
						Anziehdrehmoment Torque Couple de serrage	130 - 150 Nm		

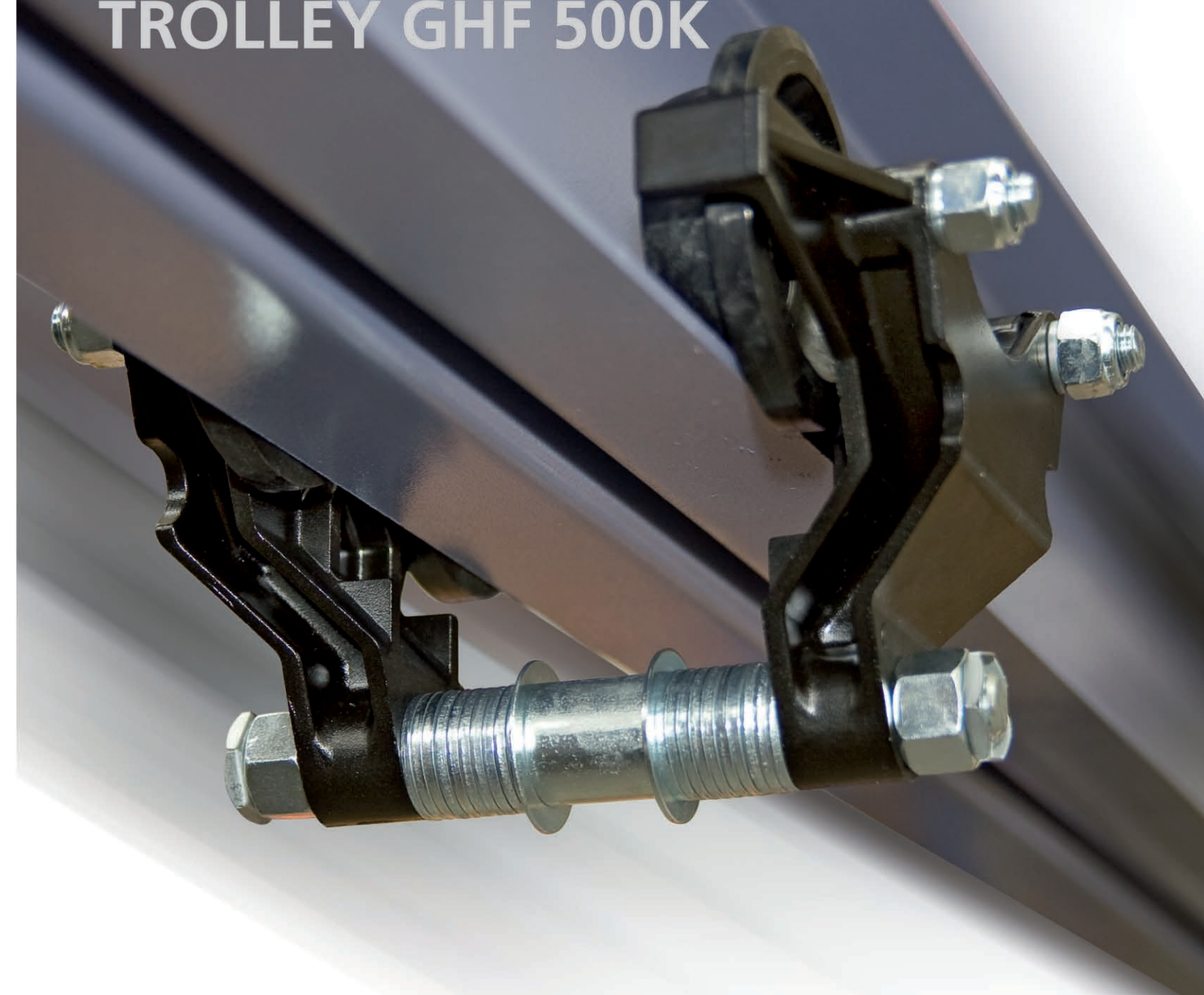
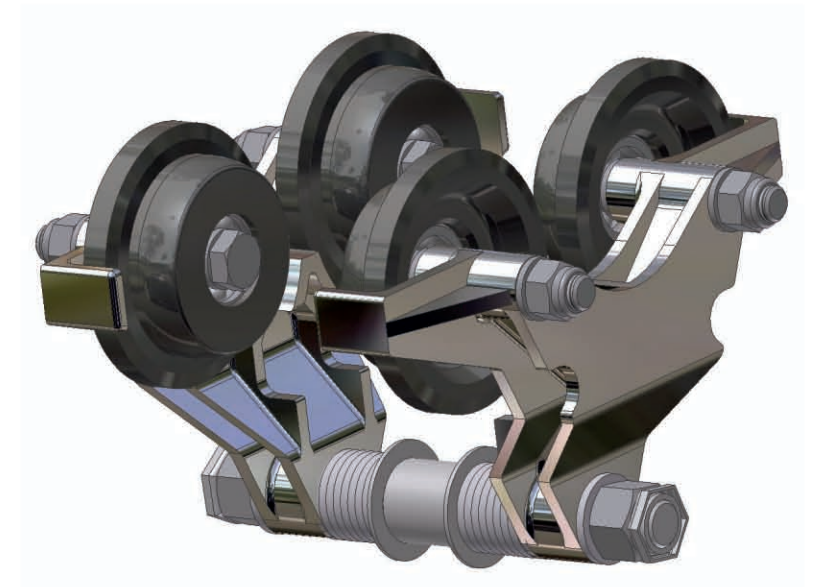

- None machining parts
- Designed with few parts only
- Easy assembling and disassembling
- Light aluminium die casting design
- High resistance glass fibre reinforced plastic wheels
- Adjustable to all I-beam widths

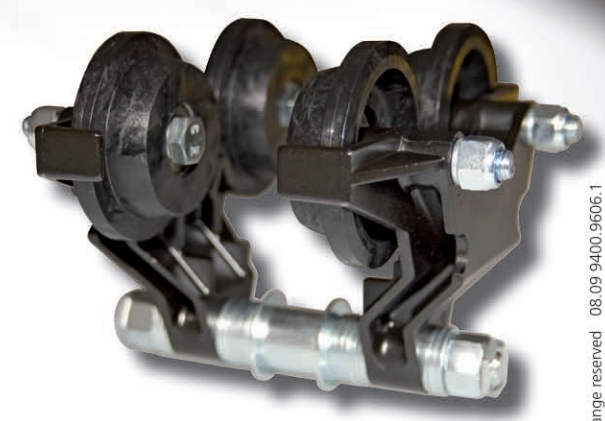

**GIS AG**  
 Hebe- und Fördertechnik  
 Luzernerstrasse 50  
 CH-6247 Schötz

Tel. +41 (0)41 984 11 33  
 Fax +41 (0)41 984 11 44  
 tel@gis-ag.ch  
 www.gis-ag.ch

**GIS** Lifting and Crane Technology  
 Faith in technology. Faith in GIS.