

PLANETA LOW HEADROOM TROLLEY HOIST - PUSH



The PLS PREMIUM Hand Chain Block and L87 trolley are combined in an integrated combination to save headroom, this is a perfect solution if space is tight.

Available from 0.5t to 20t lifting capacity

ADVANTAGES OF TROLLEY HOIST

- » Capacity from 500 kg to 20.000 kg
- » Optimal space utilisation
- » Enables low cost bridge cranes
- » Labour saving during repair and maintenance works

LOW HEADROOM TROLLEY HOIST TYPE LHT

FEATURES

- » Smooth trolley operation on ball bearing wheels plus surface protection offers the user outstanding reliability
- » Standard overload protection on Chain Hoist

STANDARD VERSION

- » PREMIUM chain hoist with 3 m lift and 2.5 m hand chain operation length
- » Available as manual push trolley (TYPE -H)
- » A contour trolley wheel design provides maximum beam contact on flat or tapered beams.

OPTIONS (ON REQUEST)

- » For corrosive environments, completely zinc plated surfaces are also available for the trolley
- » Special flange widths of up to 305 mm are possible if the specified adjustment range (dimension H) is no longer sufficient
- » Starting buffer



SPECIFICATIONS

PRODUCT CODE		PL/LHPT/005	PL/LHPT/010	PL/LHPT/015	PL/LHPT/020	PL/LHPT/020	PL/LHPT/020	PL/LHPT/050	PL/LHPT/100	PL/LHPT/200
CAPACITY	(t)	0.5	1	1.5	2	3	5	10	20	
Standard lift	(m)	3	3	3	3	3	3	3	3	3
Number of chain falls		1	1	1	1	1	2	3	8	
Chain size	(mm)	5 x 15	6 x 18	8 x 24	8 x 24	10 x 30	10 x 30	10 x 30	10 x 30	10 x 30
Min. headroom (A)	(mm)	272	270	388	388	472	595	800	965	
Flange width min. - max. (M)	(mm)	50 - 203	64 - 203	88 - 203	88 - 203	100 - 203	114 - 203	124 - 203	136 - 203	
Min. curve radius	(m)	0.85	1	1.1	1.1	1.3	1.4	2	3.5	
Reel path for 1 m lift	(m)	29.5	39.4	60.8	60.8	96.7	193.3	290	386.7	
Reel path for 1 m path LHT-G	(m)	3	3.6	4.7	4.7	5.7	6.3	8	10.6	
Dimension H min. LHT-H	(mm)	298	314	325	325	355	381	388	-	
Dimension H min. LHT-G	(mm)	342	363	374	374	403	428	445	498	
B	(mm)	238	288	338	338	390	472	476	564	
C	(mm)	352	420	487	487	566	745	940	1165	
D	(mm)	54	67	80	80	100	109	133	170	
S	(mm)	23	24	28	28	26	28	50	55	
E	(mm)	78	96	111	111	133.5	145	176	228	
F	(mm)	3	3	3	3	4	4	4	4	
J	(mm)	102	112	131	131	153	168	194	234	
R	(mm)	Ø 20	Ø 24	Ø 29	Ø 29	Ø 34	Ø 39	Ø 44	Ø 59	
Weight with 3 m lift LHT-H	(kg)	13.5	22	42	42	56	82	143	331	
Weight with 3 m lift LHT-G	(kg)	14.8	23.5	43.7	43.7	58	85	148	353	
Larger flange width (M)	min. - max. mm	64 - 305	64 - 305	88 - 305	88 - 305	100 - 305	114 - 305	124 - 305	136 - 305	

PLANETA LOW HEADROOM TROLLEY HOIST - PUSH

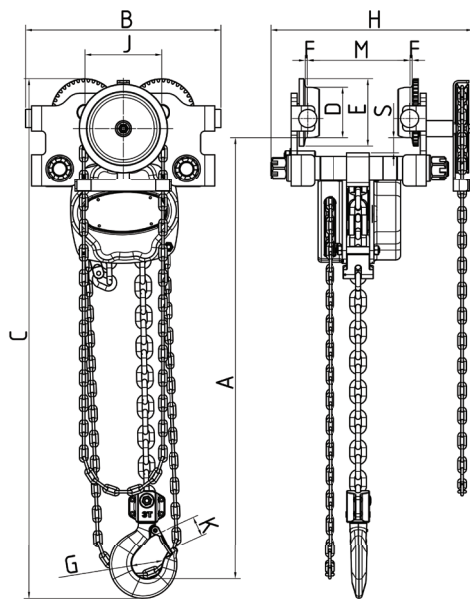

0.5 - 3.0t MODEL

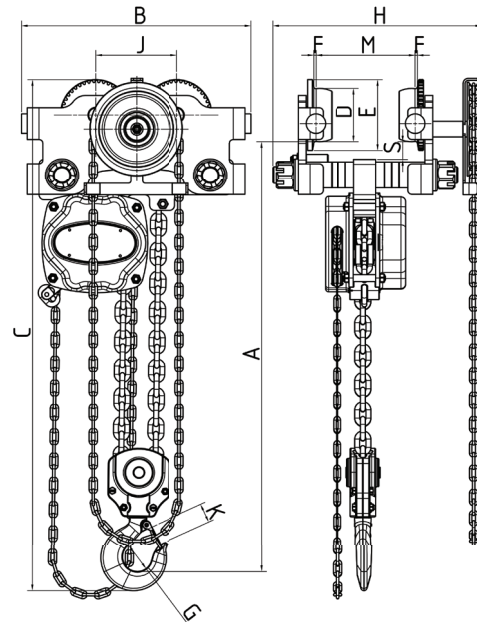

5.0t MODEL

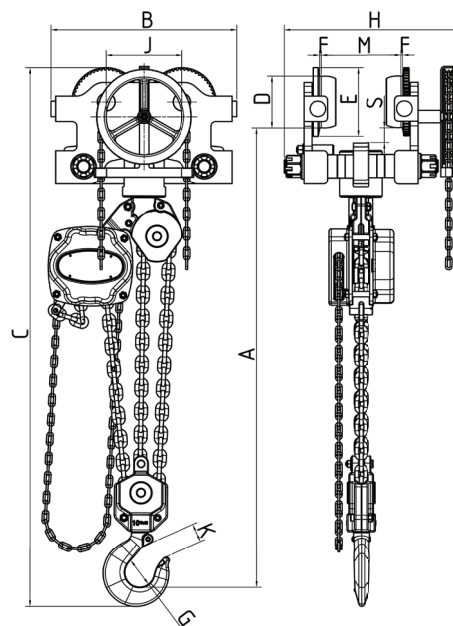

10.0t MODEL

COMPANY CONTACT DETAILS

LTM - Lift Turn Move Ltd
 Unit 2 Stadium Court
 Wirral International Business Park
 Plantation Road, Bromborough
 Wirral, UK CH62 3QG

SALES AND GENERAL CONTACTS

Tel: +44 (0)151 649 0467
 Fax: +44 (0)151 649 0099
 Email: sales@LiftTurnMove.co.uk
 Email: accounts@LiftTurnMove.co.uk
 Website: www.liftturnmove.co.uk

OPENING HOURS

Mon-Thur: 8:30 - 5:00
 Friday: 8:30 - 2:30

The office is often open outside these times.

DELIVERIES

We use various methods of delivery and can deliver more or less whenever you need.

To stay up to date with the latest events at LTM please follow us on Facebook, Twitter and LinkedIn



[liftturnmove](https://www.facebook.com/liftturnmove)



[@LiftTurnMove](https://twitter.com/LiftTurnMove)



[@Lift Turn Move Ltd](https://www.linkedin.com/company/liftturnmove)