



TRANSLATION OF THE  
**ORIGINAL INSTRUCTION MANUAL**  
ELECTRIC CHAIN HOIST TYPE LP





# Table of contents

Spare parts / Ordering spare parts .....	4
<b>0 General instructions.....</b>	<b>5</b>
0.1 General safety instructions .....	5
0.1.1 Safety and hazard information .....	5
0.2 General safety regulations and organisational measures .....	5
0.2.1 Warning markings / Legends / Warning signs.....	5
0.3 Particular safety instructions.....	5
0.4 Instructions for hazard protection .....	6
0.4.1 Hazards - Mechanical .....	6
0.4.2 Hazards - Electrical.....	7
0.4.3 Sound pressure level .....	7
0.5 Technical status .....	7
0.5.1 Periodic checks .....	8
0.5.2 Warranty.....	8
0.6 Intended use .....	8
0.6.1 Instructions for using the instruction manual .....	10
<b>1 Description .....</b>	<b>10</b>
1.1 Operating conditions .....	10
1.2 General description.....	12
<b>2 Start-up .....</b>	<b>13</b>
2.1 Transport and assembling.....	13
2.2 Connecting.....	14
2.2.1 Electrical connection.....	14
2.2.2 Braking system.....	15
2.2.3 Load chain.....	16
2.2.4 Limit switch.....	17
2.2.5 Chain container.....	17
<b>3 Care and maintenance.....</b>	<b>18</b>
3.1 General guidelines for maintenance and servicing.....	18
3.2 Care and maintenance.....	19
3.2.1 Care overview .....	19
3.2.2 Maintenance overview .....	19
3.2.3 Braking system.....	19
3.2.4 Load chain.....	20
3.2.5 Chain guide .....	21
3.2.6 Limit stop .....	21
3.2.7 Gearing .....	21
3.2.8 Slipping clutch.....	21
3.2.9 Suspension parts .....	21
<b>4 Measures for achieving safe operating periods .....</b>	<b>22</b>
4.1 Determining the actual operating time .....	22
4.2 General overhaul.....	22
<b>5 Appendix .....</b>	<b>24</b>
5.1 Technical data .....	24
5.2 Electrical parameters.....	26
5.3 EC Declaration of conformity .....	28
5.4 EC Declaration of incorporation.....	29

# Spare parts / Ordering spare parts

The correct order numbers for original spare parts can be obtained from the relevant spare parts list. Please ensure that you have the following data on your chain hoist to hand. This will enable the correct spare parts to be supplied without delay.

Electric chain hoist type:

---

Serial number:

---

Year of manufacture:

---

Load capacity:

---

Original spare parts for the electric chain hoists can be acquired from the following addresses:

## Manufacturer

GIS AG  
Swiss Lifting Solutions  
Luzernerstrasse 50  
CH-6247 Schötz

Tel. +41 (0)41 984 11 33  
Fax +41 (0)41 984 11 44  
tel@gis-ag.ch  
www.gis-ag.ch

## Resellers / Agent

---

---

---

---

---

---

---

---

# 0 General instructions

## 0.1 General safety instructions

### 0.1.1 Safety and hazard information

The following symbols and terms are used in this instruction manual for safety and hazard instructions:



**DANGER !**

Non-compliance, either in part or full, with operating instructions with this symbol can result in serious personal injury or fatal accidents. Warning information must be **strictly** adhered to.



**CAUTION !**

Non-compliance, either in part or full, with operating instructions with this symbol can result in major damage to machinery, property or material. Information in the category "Caution" is to be **exactly** adhered to.



**NOTE**

Following the instructions marked with this symbol will lead to more effective and straightforward operation. "Note" directions make work easier.

## 0.2 General safety regulations and organisational measures

The instruction manual for the electric chain hoist must always be available within the operating area of the hoist. The instructions mentioned in this manual must be strictly adhered to. Furthermore, supplementary to the instruction manual, the statutory regulations governing general accident prevention and environmental protection are to be enforced.

Operating and service personnel must have read and understood the instruction manual, in particular the safety instructions, before commencing work. Protective equipment must be made available for operating and service personnel and worn at all times. The operator or his representative is responsible for supervising operating personnel and ensuring they are aware of the hazards and safety implications of working with the electric hoist.

The manufacturer reserves the right to make technical changes to the product or changes to these instructions and assumes no liability for the completeness and up-to-dateness of these instructions. The original version of these instructions is in the German language. In case of doubt, the original German original version is exclusively valid as a reference document.

### 0.2.1 Warning markings / Legends / Warning signs

- Oil chain.....figure 0-1
- CE sign .....figure 0-2
- Type plate ..... figure 0-3
- Data plate ..... figure 0-4
- Voltage..... figure 0-5

Figure 0-1

Figure 0-2

Figure 0-3

Figure 0-4

Figure 0-5

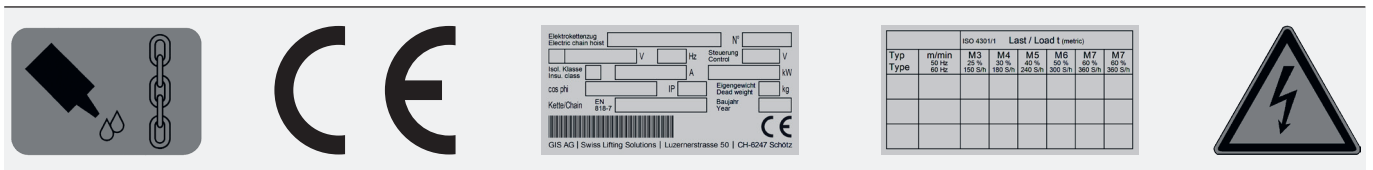

## 0.3 Particular safety instructions

**Transport and assembly:**

- Electric chain hoists, single parts and large components should be carefully fixed to suitable and technically acceptable hoisting apparatus / load lifting members.

**Electrical connection:**

- Connection work is only to be performed by personnel specifically designated and trained for the job.

**Start-up / operation:**

- Before initial start-up, as well as daily start-up, carry out a visual check and carry out the predefined user-checks routine.
- Only operate the electric chain hoist if the protective and safety equipment provided is ready and working.
- Damage to the electric chain hoist and changes in its operational characteristics must be reported immediately to the responsible person.
- After use, or when in a non-operational mode, the chain hoist should be secured against unauthorised and unintentional use.
- Refrain from hazardous procedures.

See also operational parameters (chapter 0.6).

**Cleaning / service / repair / maintenance / refitting:**

- Use working platforms provided for assembly work at high level.
- Do not use machine parts for this purpose.
- Check electrical cables for damage or wear.
- Ensure any oils or other agents used are collected and disposed of safely and in an environmentally sound manner.
- Reassemble and check safety installations that have been disassembled for servicing or repairing the hoist once service and repair work has been completed.
- Adhere to predefined testing and service intervals specified in the instruction manual.
- Follow the directions in the instruction manual regarding exchanging parts.
- Operating personnel should be informed before commencing special or refitting work.
- Secure the repair working area.
- Prevent the electric chain hoist from being unexpectedly switched on during service or repair work.
- Erect warning signs.
- Disconnect the power cable and ensure it cannot be switched on again by unauthorized personnel.
- Retighten screw connections that have been loosened for repair or service work.
- Replace non-reusable fixing elements and seals (e.g. self-locking nuts, washers, cotter pins, O-rings and seals).

**Shut down / storage:**

- Clean and preserve (lubricate/grease) the chain hoist before long periods of inactivity or storage.

## 0.4 Instructions for hazard protection

Hazardous areas must be clearly marked by warning signs and cordoned off. It must be ensured that warnings regarding hazardous areas are given due attention.

**Hazards can stem from:**

- incorrect application
- not following safety directions properly
- not carrying out test and service work thoroughly

### 0.4.1 Hazards - Mechanical

**Physical injury:****Unconsciousness and injury through:**

- crushing, shearing, cutting and twisting
- drawing in, ramming, piercing and rubbing
- slipping, stumbling and falling

**Causes:**

- crushing, shearing and twisting
- parts rupturing or bursting

**Safety options:**

- keep floor, equipment and machinery clean
- eliminate leakages
- observe the required safety distance

#### 0.4.2 Hazards - Electrical

Work on electrical apparatus or machinery may only be performed by qualified electricians or persons under the supervision and guidance of qualified electricians, in accordance with predefined electro-technical regulations.



##### Physical injury:

##### Death from electrical shock, injury and burns through:

- contact
- faulty insulation
- faulty servicing or repair work
- short circuit

##### Causes:

- contact with, touching or standing too close to uninsulated power and live parts
- use of uninsulated tools
- exposed electricity supply terminals following insulation failure
- inadequate safety checks following repair work
- incorrect fusing

##### Safety options:

- Isolate machinery and equipment designated for repair or service work before commencing such work.
- First check isolated parts for voltage.
- Regularly check electrical fittings.
- Replace loose or damaged cables immediately.
- Always replace blown fuses with fuses of the correct type/value.
- Avoid contact with or touching live terminals.
- Only use insulated tools.

#### 0.4.3 Sound pressure level

Tests on the chain hoist sound level are performed at a range of 1, 2, 4, 8 and 16 metres from the centre of the chain hoist motor to the measuring device. Measurement of SPL according to DIN 45 635.

The SPL was measured:

- a) During operation of electric chain hoists on factory site.
- b) During open-air operation of electric chain hoists.

Table 0-1 Sound level

Measuring distance		1 m	2 m	4 m	8 m	16 m
Types	Measurement type	dBA				
LP 500	a	65	62	59	56	53
	b	65	59	53	47	41
LP 500 1Ph	a	76	73	70	67	64
	b	76	70	64	58	52
LP 1000	a	80	77	74	71	68
	b	80	74	68	62	56



When working in a noisy environment, the use of ear protection is recommended.

## 0.5 Technical status

This instruction manual was issued in 2016. It corresponds to directive 2006/42/EC of the European Parliament and council of 17 May 2006. The LP models are calculated for the case of operation with a shock factor of 1.4 (according to DIN EN 818-7 with max. 8 m/min.). The accidents audited by the laboratory generate smaller shock factors than the normal mode.

### 0.5.1 Periodic checks

Each device/unit operator should adequately note all checks, maintenance and inspections performed in the log book, and have these confirmed by the competent person in charge. Incorrect or missing entries will lead to forfeiture of the manufacturer's warranty.



Equipment and cranes are to be checked periodically by a specialist. Primarily, visual and functional checks are to be carried out, whereby the state of components with respect to damage, wear, corrosion or any other changes are determined. In addition, safety equipment is assessed for completeness and efficiency. It may be necessary to dismantle the equipment to correctly assess wear parts.



Suspensions must be inspected over its entire length, including covered or hidden parts.



All periodical inspections should be arranged by the operator.

### 0.5.2 Warranty

The warranty is void if the installation, operation, testing and maintenance is not carried out according to this manual. Repairs and troubleshooting under warranty may only be carried out by qualified persons after consultation and agreement with the manufacturer / supplier. Any modifications to the product or the use of non-original spare parts will void the warranty.

## 0.6 Intended use

They can be installed as stationary or mobile units. The electric chain hoists are manufactured in accordance with the latest technical developments and recognised safety standards, and are tested for safe operation by the manufacturer. Electric chain hoists are approved by various international classification societies such as TÜV and others. Electric chain hoists of the above types may only be used when in an acceptable technical condition, in accordance with their intended use, by trained personnel in a safe and responsible manner.

#### General operating conditions:

- Ambient temperature ..... : -15 °C to +50 °C
- Humidity ..... : max. 80% relative humidity
- Protection class ..... : IP 65
- Electromagnetic compatibility ..... : immunity industrial area

We recommend to equip GIS chain hoists working outdoors with a shelter against the weather. Special operating conditions can be agreed in individual cases with the manufacturer. After consultation, appropriate, optimized equipment, and important information for safe, low-wear use can be supplied. The intended use of the electric chain hoist likewise assumes the adherence to the operating, maintenance and servicing prescribed by the manufacturer.

Ensure that only one type of hoist from the same manufacturer with the same speed is used to lift each assembly. Different hoists or hoists with different lifting capacity/speeds should not be used to lift one rig. Note that different manufactured hoists and hoists with different lifting capacities even when noted with the same hoisting speed will run at different speeds.

The electric chain hoists in the LP series are designed for provision and use at events. Events include concerts, shows, events, conventions, conferences, exhibitions, presentations, demonstrations, cinema or television recordings and the like. Venues include theatres, multi-purpose halls, studios, production facilities for film, television and radio, concert halls, convention centres, schools, exhibitions, trade fairs, museums, discos, variety shows, theme parks, sports facilities, open air theatres and open-air events.

There are three types of electric chain hoists:

#### D8 Hoist

Electric chain hoist DGUV-54 (BGV-D8) "Winches, lifting and pulling devices" as construction chain hoists for lifting loads.



**D8 PLUS Hoist**

Electric chain hoist DGUV-54 (BGV-D8) "Winches, lifting and pulling devices" as construction chain hoist for lifting loads with the particular feature to hold loads over persons in the idle state without secondary safety.

**C1 Hoist (scenery hoist)**

Electric chain hoist DGUV-17 (BGV-C1) "Venues and production sites for stage performances" for holding and moving loads above persons.

The types of electric chain hoists listed above can be operated both individually and in groups.

Electric chain hoists are offered in a variety of types and equipment variants and with different safety devices. Therefore, the choice of chain hoists are of considerable importance. Here, the resulting hazards from the type of use hazards are to be based in compliance with the specific conditions of use. The selection of the type of the electric chain hoist is dependent on the operating conditions.

Table 0-2 Operating conditions

In the presence of persons under the load				
Use	D8	D8 with secondary safety device	D8 PLUS	C1
Assembly and dismantling, set up mode	inadmissible	inadmissible	inadmissible	permissible
Holding loads	inadmissible	permissible	permissible	permissible
Scenic movement	inadmissible	inadmissible	inadmissible	permissible

For hoists permanently installed in venues facilities, due to the operation and the expected hazard, electric chain hoists according to DGUV 17 (BGV-C1) are to be deployed.

**Improper use comprises:**

- exceeding the defined maximum permissible load capacity
- pulling the load diagonally (maximum angle 4°, see figure 0-5)
- heaving, pulling or dragging the load
- transporting persons
- transporting excessive loads
- pulling on the control cable
- failing to observe the load hook constantly
- running the chain over edges
- failing to observe the load constantly
- allowing the load to fall due to a slack chain
- use in an explosive environment

See also chapter 0.3.

Excessive inching operations, ground mooring and driving against the limit stops should be avoided. The manufacturer accepts no liability for damage to equipment and third parties ensuing from such action.

Figure 0-5

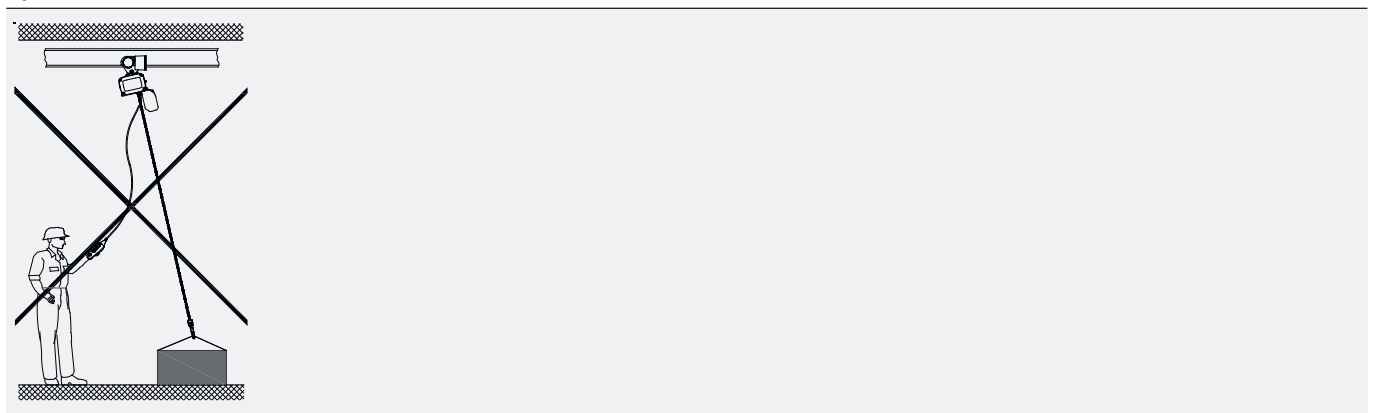

### 0.6.1 Instructions for using the instruction manual

This instruction manual includes the following chapters:

0 General instructions	3 Care and maintenance
1 Description	4 Measures for achieving safe operating periods
2 Start-up	5 Appendix

Supplementary to the instruction manual, the following documentation from the operator must be noted:

- Declaration of conformity
- Inspection pass
- Spare parts list(s)
- Circuit diagrams

#### Page- and figure numbering:

The pages are consecutively numbered. Blank pages are not numbered, however are calculated together with the consecutive pages. Figures are numbered consecutively by chapter. Example: Figure 3-1 means: in chapter 3, figure 1.

# 1 Description

The LP series includes the following models: D8, D8 PLUS, C1.

## 1.1 Operating conditions

#### Classification according to application requirements:

Electric chain hoists and trolleys are categorised according to the following regulations into classifications:

- DIN EN 14492-2
- DIN 15401 (load hook)
- FEM calculation regulations for series lifting equipment (chain drive, motor, full load-life cycle)
- Remarks about general overhaul (see chapter 4)

There is different coefficient data for the classifications that must be adhered to in operation.



The travel trolley must have at least the same lifting capacity as the electric chain hoist.



The classification of the electric chain hoist can be found on the data plate.

The manufacturer will only guarantee the safety and lasting operation of the electric chain hoist when used for applications in accordance with valid standard values that fall within its classification.

Before the first start-up, the user must estimate according to the parameters in table 1-1, which of the four types of load is applicable to the use of the electric chain hoist during its whole life cycle. The table 1-2 shows standard values for the operating conditions of the classifications depending on the type of load and time of operation.

Table 1-1 Load collective

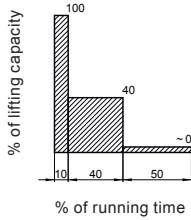
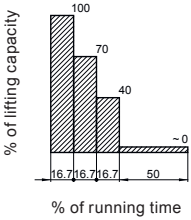
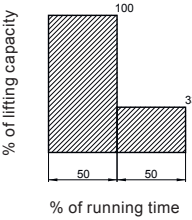
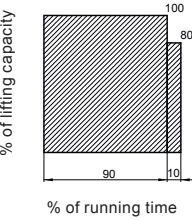
Type of load 1 light $k < 0.50$ $k = 0.50$	Type of load 2 medium $0.50 < k < 0.63$ $k = 0.63$	Type of load 3 heavy $0.63 < k < 0.80$ $k = 0.80$	Type of load 4 very heavy $0.80 < k < 1.00$ $k = 1.00$
			
Full load by way of an exception, however predominantly low loads	Frequently fully loaded, however continuously lightly loaded	Frequently fully loaded, continuous average loading	Regular full load

k = Load collective (type of load)

Table 1-2 Operating conditions

Classification according to ISO 4301-1	M3	M4	M5	M6	M7
Load collective	Average running time per working day [h]				
1 - light $k < 0.50$	up to 2	2 - 4	4 - 8	8 - 16	over 16
2 - medium $0.50 < k < 0.63$	up to 1	1 - 2	2 - 4	4 - 8	8 - 16
3 - heavy $0.63 < k < 0.80$	up to 0.5	0.5 - 1	1 - 2	2 - 4	4 - 8
4 - very heavy $0.80 < k < 1.00$	up to 0.25	up to 0.5	0.5 - 1	1 - 2	2 - 4

**Ascertaining the correct type of application for an electric chain hoist:**

Either the running time or expected type of load can be used as a basis for ascertaining the correct type of application for the electric chain hoist.



Before initial operation of the electric chain hoist, it must be set, according to which load types contained in table 1-1 the electric chain hoist must be operated. Assignment to a load type or a load collective (k) applies for the whole life cycle of the equipment and may not be altered for operational safety reasons.

**Example 1: Calculate permissible running time of the electric chain hoist**

An electric chain hoist of the classification M4 is to be used for medium stress load tasks throughout its whole life cycle. This corresponds to the type of load <3 heavy> (see table 1-1). Corresponding to the values in table 1-2, the hoist should not be used for more than 0.5-1 hour per day.

**Example 2: Calculate the permissible type of load**

An electric chain hoist of the classification M5 is to be used for approximately 6 hours per working day, throughout its whole life cycle. Thus, the electric chain hoist must be operated according to the characteristics of the type of load <1 light> (see table 1-1).

## 1.2 General description

Figure 1-1

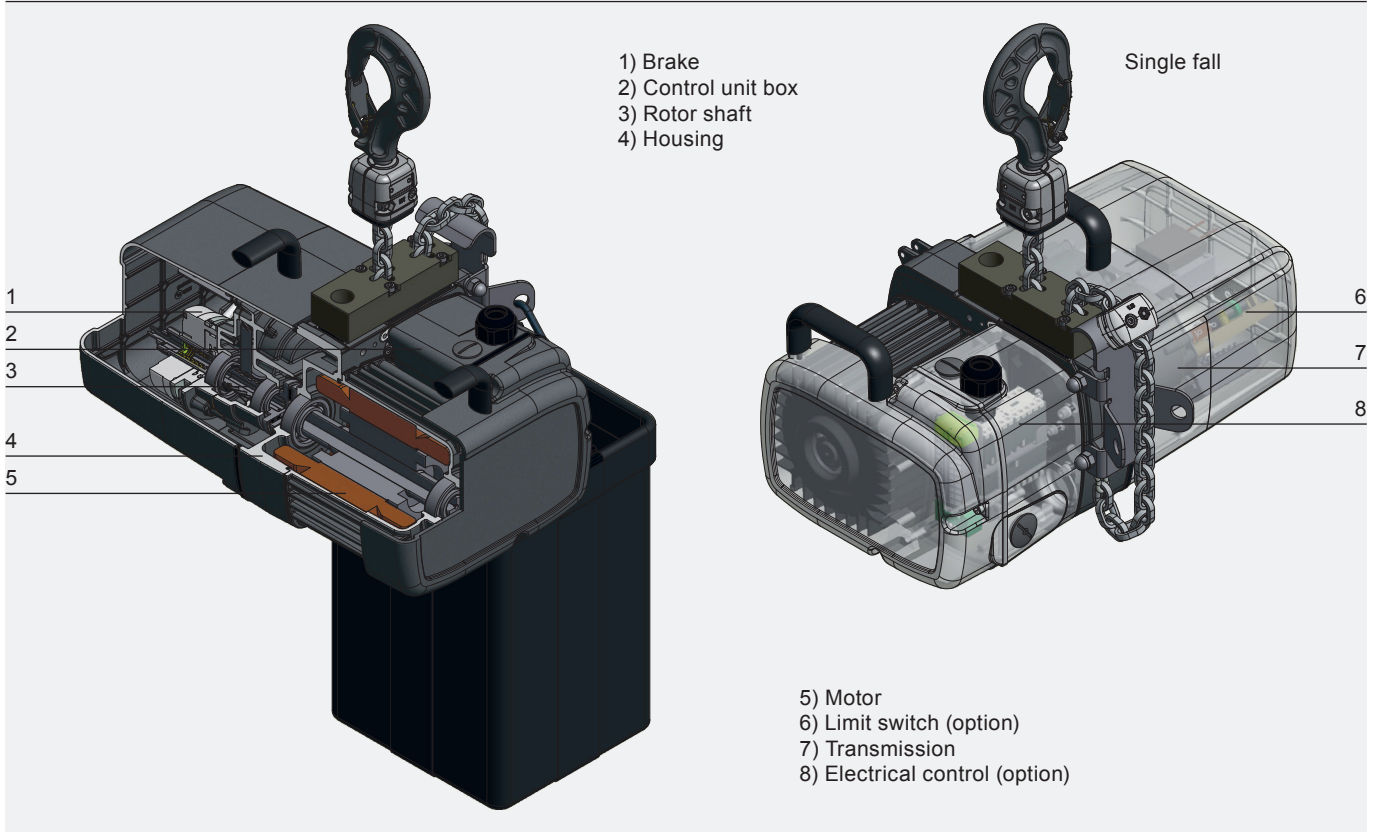

The electric chain hoist meets the requirements of the EC Machinery Directive and the relevant EN and FEM standards. Housing and cover are made of a sturdy die-cast aluminium. On engine cooling fins ensure optimum cooling. The chain container can be attached to the compactly constructed housing. A drilled hole is provided for both the power supply cable gland and the control cable. At the housing eyebolt suspension or optionally hook suspension, are attached. The electric chain hoists of the LP series are suitable for use as a climbing hoist. Two carrying handles (figure 1-2) facilitate the transport of the chain hoists.

GIS electric chain hoists are driven by asynchronous motors. The braking system consists of a DC-operated spring-loaded brake. When there is no current, the pressure spring generates the braking torque.

The slipping clutch is built in front of the braking system according to its function. It protects the hoist from overload and takes on the function of an emergency stop for the highest and lowest hook positions. The electric chain hoists of the LP series are suitable for direct control.

The high tensile Profile Steel Chain corresponds to grade DAT (8SS) according to DIN EN 818-7. The chain wheel is hardened. The load hook, which complies with DIN 15401, is fitted with a safety catch.

The 3-stage enclosed spur gears are generally helical. The gears are mounted on roller bearings and run greased.

Additional equipment of D8 PLUS electric chain hoists:

- at least 8-times resistance to fracture in accordance with DIN 56950 (at least 10 times by IGWV 3QP2)
- second parallel brake (figure 1-3)

Additional equipment of C1 electric chain hoists:

- at least 10 times resistance to fracture DIN 56950
- second parallel brake (figure 1-3)
- geared limit switch with downstream emergency limit switch (figure 1-4, Pos. 1)
- incremental encoders on the sprocket (figure 1-4, Pos. 2)
- eyebolt suspension with integrated load sensor (figure 1-5)

Options:

- integrated contactor control with emergency stop contactor (figure 1-6)
- safety load hooks (figure 1-7)
- absolute encoder

Figure 1-2

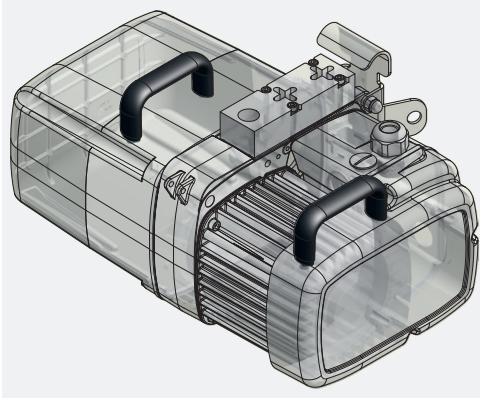

Figure 1-3

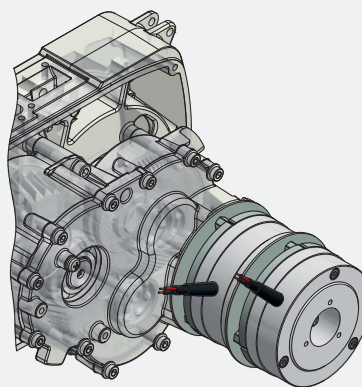

Figure 1-4

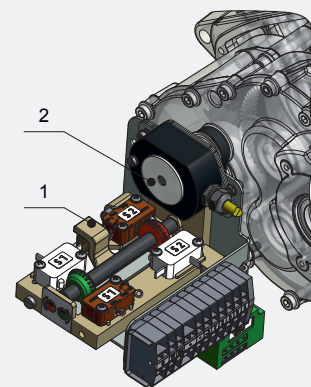

Figure 1-5

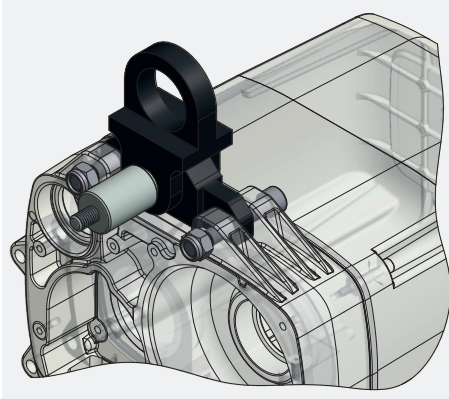

Figure 1-6

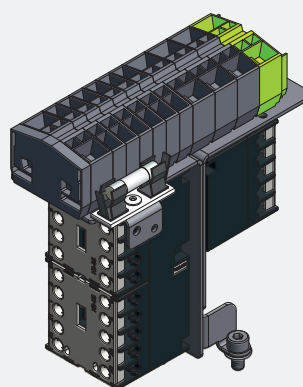
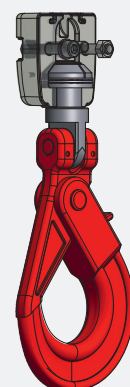

Figure 1-7



## 2 Start-up



Mechanical adjustments may only be performed by authorised specialists.



Operating staff must carefully read the instruction manual of the electric chain hoist before initial operation and carry out all the checks. Only after safe operation has been established, the device is put into operation. Unauthorised persons may not operate the device or carry out work with it.



The operator must create an inspection pass when starting-up the electric chain hoist. The inspection pass contains all the technical data and the date of start-up. It provides a record of all servicing and maintenance work.

### 2.1 Transport and assembling

The safety directions for handling with loads should be followed (see chapter 0.3) when transporting and assembling the electric chain hoist. Electric chain hoists must be assembled by qualified staff, always bearing in mind the accident prevention directions in chapter 0.2. Before start-up, the electric chain hoist must be stored in a closed room or covered area. Should the electric chain hoist be destined for operation outdoors, then it is recommended that a protective cover is erected to shield it from the effects of the weather.

Wherever possible, the electric chain hoist should be transported in its original packaging. The goods delivered should be checked for completeness and the packaging has to be disposed in an environmentally sound manner. It is recommended that the electric chain hoist is assembled and connected on-site by our qualified customer service engineers. On the type plate it must be checked whether the hoist corresponds to the version ordered (D8 / D8 PLUS / C1).

**The electric chain hoist must have the following identification:**

- Electric chain hoist D8 ..... : triangle
- Electric chain hoist D8 PLUS ..... : square
- Electric chain hoist C1 ..... : circle

## 2.2 Connecting

### 2.2.1 Electrical connection



Electro-technical adjustments may only be performed by authorised specialists.

The mains connection cable, the mains connection fuse and the main control switch for connecting the electric chain hoist to the mains power supply must be provided by the customer. A 4-wire cable with a PE protective conductor is needed to provide the power supply for three-phase versions. A 3-wire cable with a protective conductor is adequate for single-phase version. The length and cross-section must be appropriate for the power consumption of the electric chain hoist. The wiring diagram is located in the lid of the electric chain hoist. In D8 PLUS electric chain hoists, the power supply must be interrupted by means of a lockable switch, after reaching the desired position. The control system must be fitted with an emergency stop button which are monitored. Power should be disconnected from control units when hoists are not in use. Only experienced and competent users may operate lifting systems or single hoists. The principles according to BGG 912/GUV-G 912 are to be applied. A test log is to be created consisting of the installation documentation from the manufacturer and the test records. Plans and descriptions for electrical installation are specific projects complemented by the appropriate control engineer.

- Before connecting the electric chain hoist, check whether the operating voltage and frequency that are specified on the type plate correspond to the available power supply.
- Remove the cover from the control unit box.

**Connection with direct control:**

- Introduce the connection cable with cable gland M25 × 1.5 in the lower hole and according connect according to the attached electrical chart to L1, L2, L3 and PE (see figure 2-1).
- With direct operated chain hoists without PMS relay contact is provided for connection of the brake. The brake must be switched on the direct current side.

**Connection with contactor control:**

- Align connection cable with cable gland M25 × 1.5 in lower hole and connect according to the attached electrical chart to L1, L2, L3 and PE (see figure 2-2).
- Align control cable through cable gland M20 × 1.5 into the hole below the casing and connected to terminals 1, 2, 3, 4, 10 (see figure 2-3).

Figure 2-1

Figure 2-2

Figure 2-3

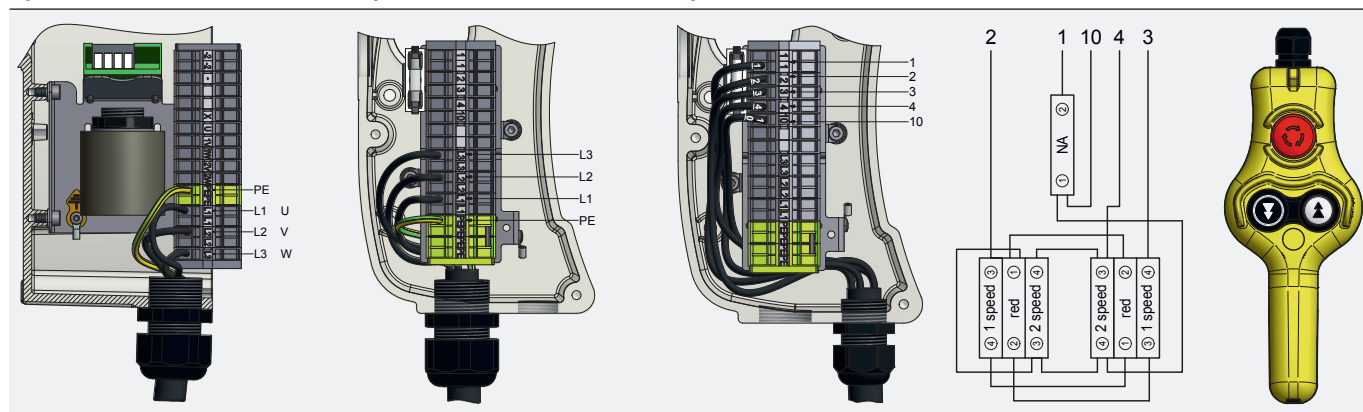

When using a control switch:

- strain relief to housing (see figure 2-4)



The control switch must be attached to the strain relief cord and not to the cable.



The protective conductor should not conduct any current. With the installation of a motor protector, the current of the electric chain hoist must be observed according to the type plate.



Checking direction of rotation: If the directions of movement do not match the button symbols of the control switch, the supply line wires L1 and L2 must be changed. In the single-phase version, inching operations can cause malfunctions.



Opening of the terminal that is used in accordance with figure 2-5.

Figure 2-4

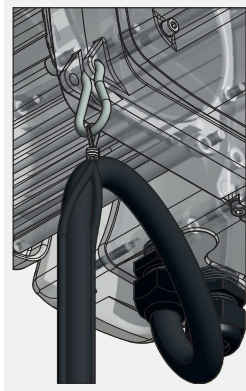
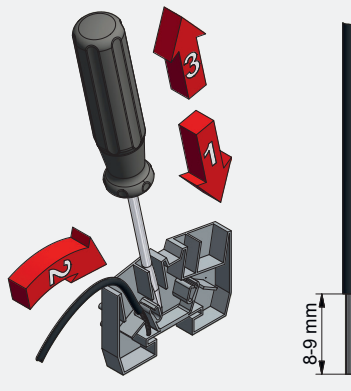

Figure 2-5



### 2.2.2 Braking system

The brake must be able to hold the nominal load in power free mode without any problems. For chain hoists with two brakes, the functionality of the brakes must be checked during the acceptance of the system. The first brake on the DC side, the second brake switched on the AC side and thereby switches slightly delayed.

The functional tests on two braking systems are carried out under nominal load:

#### 1. Brake:

Release the mounting screws of the 2nd brake. The rotor of this brake now rotates freely. The function of the second brake is disconnected. Raise and lower: The first brake must be capable of braking and hold the nominal load. Tighten the mounting screws again after the function test.

#### 2. Brake:

Electrical Method:

The first brake is released from + and - terminals and activated by a non-controlled current source (directly from L1 and L2). To activate a rectifier must be switched between. Thus, the first brake is disconnected and the second brake can be tested by lifting and lowering the load. Lifting and lowering with unloaded first Brake: The second brake must be capable of braking and hold the nominal load. After the function test reconnect the first brake to the terminals + and -.

Mechanical method:

With a tool, the pressure ring of the first brake is pressed to the solenoid, so that the rotor of the brake can rotate freely. The function of the first brake is disconnected. Lifting and lowering with unloaded first brake: The second brake must be capable of braking and hold the nominal load.

### 2.2.3 Load chain



- Only use original chains.
- Welded seam of the chain links must face inward on the chain wheel (see figure 2-5).
- When used as a climbing hoist, make sure that the entry and the outlet of the chain is not prevented by chain clusters.
- The geared limit switch must be mechanically set for pulling in the chain, see chapter 2.2.4.

Before start-up and during operation, the load chain must be oiled along its full length. Oil must constantly be present on the internal, contacting and rubbing surfaces of the chain links. Lubrication is carried out by submersion or with an oil can, using a creeping gear oil. The end of the chain (1) should be attached to a flexible piece of wire or chain pulling loop (2) and fed through the chain wheel (3) of the electric chain hoist. Through short switching impulses, the chain will be pulled in correctly according to figure 2-5. The lifting height must be adjusted such that the hook fittings lie on the ground in the lowest hook position.

Figure 2-5

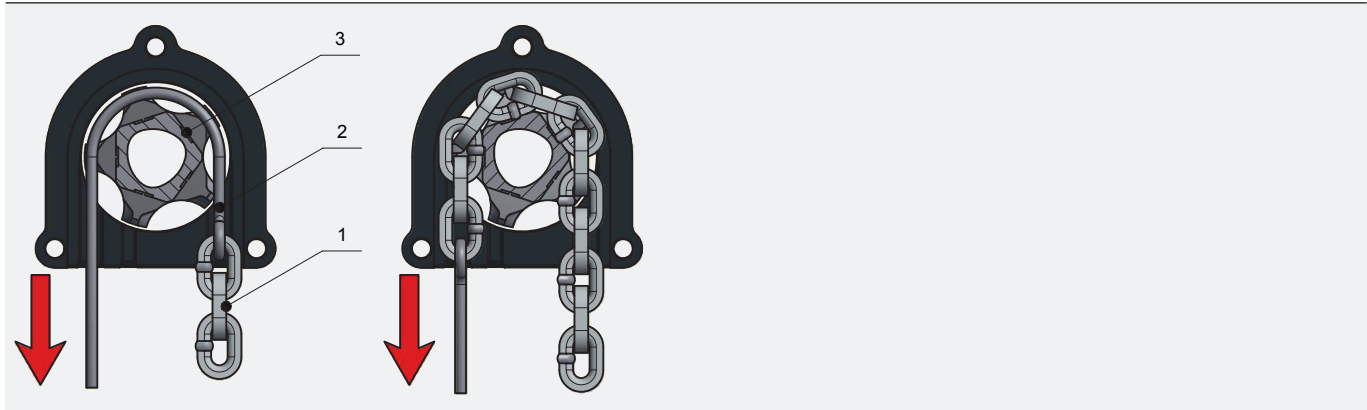

#### Chain end:

The chain end is to be fixed to the housing according to figure 2-6. The section of chain after the limit stop (1) must be adjusted to the height of the chain container. Here, the length of the chain section must be selected that the limit stop lies on the floor of the container when the chain is pulled into it.

#### 1 fall operation:

The load hook (1) is connected to the chain with a single fall hook clamp (2). For the power transmission, the mounting of the bolt (3) is important (see figure 2-7).



- Note correct arrangement of suspension (mass k1, see figure 2-8):  
LP 500 = 41 mm, LP 1000 = 43 mm.
- Grease the bearings thoroughly.

Figure 2-6

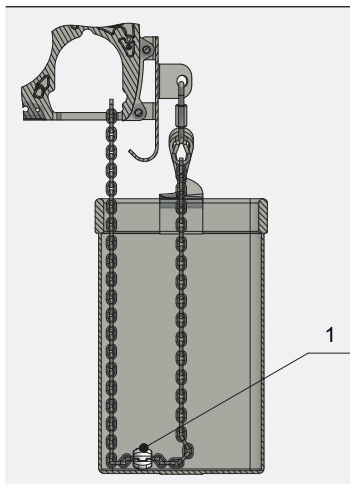

Figure 2-7

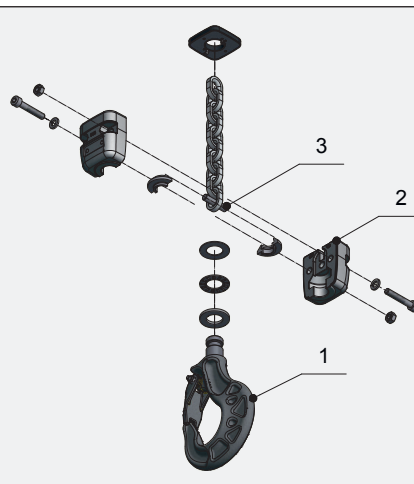

Figure 2-8





### 2.2.4 Limit switch



In direct-operated electric chain hoists no termination circuit is installed. It is important to ensure that is not operationally driven against the housing. The gearing of the protective controlled electric chain hoist is only allowed for control voltage up to 230 V AC.

In electric chain hoists with contactor control, a gear is built in as standard. This is also suitable for normal limit switch operation with a high degree of accuracy. The operation of the limit switches (highest and lowest hook position) must be checked during start-up. Three different transmission gearings are available that are adapted to the lift:

LP 500			
Transmission	Colour	1 fall lift [m]	
i = 1:1	black	20	
i = 1:3	yellow	60	
i = 1:6	blue	126	

LP 1000			
Transmission	Colour	1 fall lift [m]	
i = 1:1	black	30	
i = 1:3	yellow	90	
i = 1:6	blue	192	

#### Description of settings (see figure 2-12):

- Before pulling in the chain or changing the chain, the geared limit switch must be set mechanically inactive by pressing the rocker (1).
- Pulling the chain.
- Travel to the hook's highest position, turn the red control wheel (2, rear) to the cam of the limit switch above (3) turn (turn lower hook position clockwise, higher hook position anti-clockwise).
- Enable rocker (1) (must engage in control wheel).
- Bring the hook to its lowest position, press the rocker (1) and turn the green control wheel (4, front) to the cam of the limit switch below (5) (turn lower hook position clockwise, higher hook position anti-clockwise).
- Enable rocker (1) (must engage in control wheel).



Check the limit switching function: The limit stop and the hook fittings may not contact the housing. Check downstream emergency limit switch.

### 2.2.5 Chain container

- Textile chain container are suitable for vertically mounted electric chain hoists and for climbing hoists.
- Attach free end of chain to housing (see chapter 2.2.2).
- Attach chain container and allow chain to run in: Vertically mounted chain hoist (see figure 2-13) or climbing hoist (see figure 2-14).



Chain container must hang freely. Badly lubricated chain will occupy more volume in a chain container. We recommend a maximum of 50% to 70% fullness.

Figure 2-12

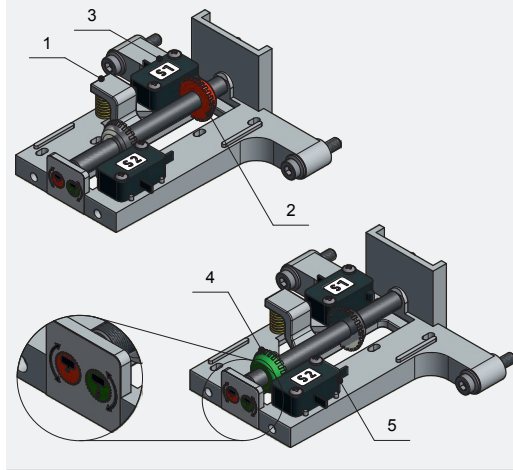

Figure 2-13

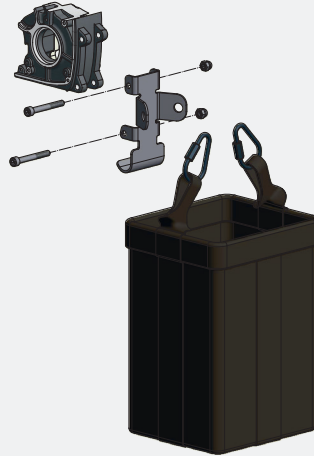
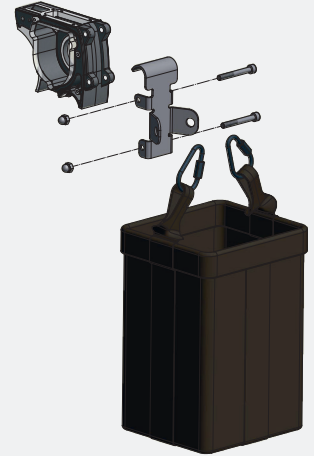

Figure 2-14



## 3 Care and maintenance

### 3.1 General guidelines for maintenance and servicing

Operating failures in electric chain hoists affecting the safe operation of the device should be remedied immediately.



Maintenance and repair work on the electric chain hoist may only be carried out by qualified and trained personnel.



If the operator performs maintenance work on an electric chain hoist on his own, the type of maintenance performed together with the date carried out must be entered in the inspection pass.

Alterations to, as well as modifications and supplements to electric chain hoists, which may affect safety, must be authorised by the manufacturer in advance. Structural alterations to chain hoists not authorised by the manufacturer exempt the manufacturer from liability in case of damage. Material warranty claims will only be recognised as valid if exclusively original manufacturer's spare parts are used. We explicitly advise that original parts and accessories not delivered by us are also not checked and released by us.

#### General:

Service and maintenance are preventive measures designed to preserve the full functionality of electric chain hoists. Non-compliance with service and maintenance routines can result in limited use and damage to electric chain hoists.

Service and maintenance should be carried out according to the instruction manual at predefined time intervals (table 3-1 and 3-2). During service and maintenance work, general accident prevention directions, special safety directions (chapter 0.3) as well as hazard protection instructions (chapter 0.4) should be followed.



Service and maintenance work should only be performed at unloaded electric chain hoists. The main switch must be off. The hook fittings must lie on the ground or on the maintenance platform.

Service work encompasses visual checks and cleaning routines. Maintenance work includes additional functional checks. During the functional checks, all fixing elements and cable clamps must be checked for tightness. Cables must be inspected for dirt, discolouration and arc spots.



Used operating materials (oil, grease, etc.) should be safely collected and disposed of in an environmentally friendly manner.

### Service and maintenance intervals are defined as follows:

d (daily), 3 M (quarterly), 12 M (annually)

The predefined service and maintenance intervals should be reduced when the loading of the electric chain hoist is exceptionally large and when frequently operated in adverse conditions (e.g. dust, heat, humidity, steam, etc.).

## 3.2 Care and maintenance

### 3.2.1 Care overview

Table 3-1 Maintenance overview

Term	t	3 M	12 M	Activity	Notes
1. Load chain	x			visual inspection clean and lubricate as needed	see chapter 2.2.2
2. Lifting device and trolley	x			check for abnormal noise / sealing	
3. Electric power supply cable	x			visual inspection	
4. Limit switch	x			function check	see chapter 2.2.3
5. Sealing		x		visual inspection	
6. Strain relief control cable	x			visual inspection	

### 3.2.2 Maintenance overview

Table 3-2 Maintenance overview

Term	t	3 M	12 M	Activity	Notes
1. Load chain		x	x	lubricate measure wear	see chapter 2.2.2 and 3.2.4
2. Braking system	x		x	function check with load	see chapter 3.2.3
3. Electrical equipment			x	function check	
4. Fixing screws on suspension parts and load hook with accessories			x	check for cracks check screw torque	see chapter 2.2.8
5. Limit switch			x	check switching elements	see chapter 2.2.3
6. Slipping clutch			x	function check	see chapter 3.2.7

### 3.2.3 Braking system

The spring-loaded brake is an solenoid operated single disk brake with two friction surfaces. The braking force is applied by springs. The braking torque is generated when no current is applied. The ventilation is solenoid. The brake operates with DC current.

The brake must be able to hold the nominal load in power free mode without any problems. For chain hoists with two brakes, the functionality of the two brakes must be checked on the system acceptance test and tested periodically. The periodic examination takes place annually by a competent person and every 4 years by an expert.

The function test is described in Section 2.2.2. The verifiability of individual brakes is ensured by the control engineer. A pattern control scheme for a D8 PLUS electric chain hoist can be obtained from GIS.



The brake coil voltage must be the same as the operating voltage.



If the maximum air gap is reached (a max., table 3-3 and figure 3-1) is reached, the lining and the brake disk must be replaced.

Table 3-3 Air gap

Term		LP 500	LP 1000	
Air gap (a)	[mm]	0.3 (+0.1 / -0.05)	0.3 (+0.15 / -0.05)	
Air gap (a max.)	[mm]	0.7	0.9	
Torque value	[Nm]	3	6	

### 3.2.4 Load chain

The load chain should be periodically checked for abrasion. The check is based on three measurements: see permissible wear and tear values (table 3-4) and measuring points (figure 3-2).

 The chain should be replaced when the measurements exceed or decrease with those defined in the table. The chain wheel and chain guidance should be checked for wear at the same time and, where necessary, be replaced. Only use original chains. The chain links should not be welded.

The new chain is installed in accordance with chapter 2.2.2.

 For ease of installation, the old chain and new chain can be connected by a piece of flexible wire.

Tabelle 3-4 Verschleisswerte Lastkette

Term		LP 500	LP 1000	
Chain type d x t	[mm]	5.25 x 15	7.45 x 23	
Tolerances according to DIN 685, part 5 DIN EN 818-7				
1. Measurement over 11 chain links, a = 11t	[mm]	168.3	258.1	
2. Measurement over 1 chain link 1t	[mm]	15.7	24.1	
3. Measurement of the chain link diameter $d_m = d_1 + d_2 / 2$ ( $d_m$ min. = 0.9 x d)	[mm]	4.7	6.7	

Figure 3-1

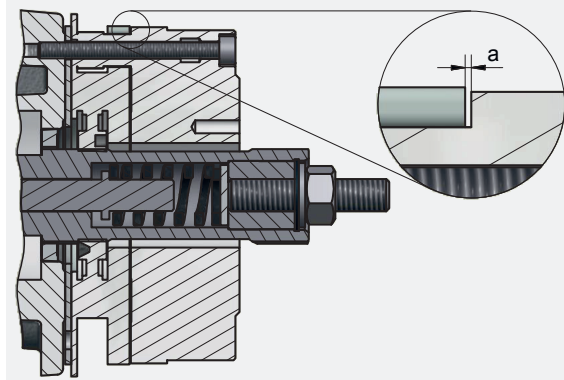

Figure 3-2

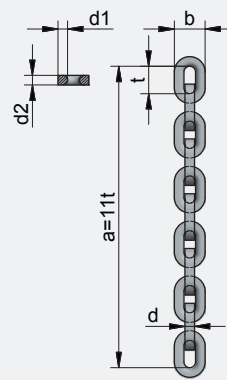
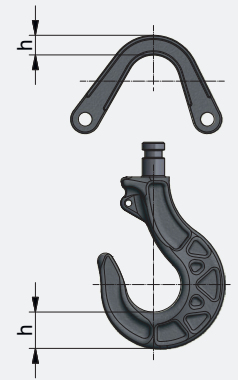

Figure 3-3



### 3.2.5 Chain guide

The inlet openings of the chain are visually inspected.



A defective wear plate, underneath the housing to replace.

### 3.2.6 Limit stop

Check screw fittings at the limit stop and single fall hook clamp and tighten with the correct torque if necessary. For coefficient data see chapter 3.2.8.

### 3.2.7 Gearing

The gear has permanent lubrication.

Lubricant.....: Strub HT PU 680

Mixable and compatible with all other brands of greases of the same type (DIN 51502: KP 1 S-20).

Lubricant quantity.....: LP 500: 70 ml, LP 1000: 160 ml.

### 3.2.8 Slipping clutch

The slipping clutch is set at the works to 125% and reliably prevents overloading of the chain hoist (the power limiting factor in accordance with DIN EN 14492-2 is  $\Phi_{DAL} = 1.4$ ). The resultant forces arising from the adjustment of the slipping clutch must be able to be absorbed by the suspension parts. The coating is wear resistant.



Adjustment and testing of the slipping clutch may only be carried out by authorised personnel and must be recorded in the inspection pass. If the nominal load is no longer lifted, or there is delay in achieving the lifting speed, the slipping clutch must be adjusted.

### 3.2.9 Suspension parts

All statically loaded parts are considered to be suspension parts. The bearing surfaces of the slewing suspension parts must be periodically greased. Torque values for screws of property class 8.8 according to DIN ISO 898:

M 4	M 5	M 6	M 8	M 10	M 12
3.3 Nm	6.5 Nm	10 Nm	24 Nm	48 Nm	83 Nm



If hook or eyelets show damage, cracks, deformation or corrosion, they must be replaced. If the prescribed dimensions (h min.) are falling short according to table 3–5 below, the parts must also be replaced. The hook safety catch must be fully functional and fully closed, replaced if necessary.

Table 3-5 Wear values suspension parts

Suspension part		LP 500	LP 1000	
Load hook	h [mm]	28.0	35.5	
	h min. [mm]	26.6	33.8	
Hook suspension	h [mm]	28.0	35.5	
	h min. [mm]	26.6	33.8	
Eyebolt suspension	h [mm]	15.0	20.0	
	h min. [mm]	14.3	19.0	

## 4 Measures for achieving safe operating periods

The statutory and health requirements of the EU regulations stipulate that specific dangers which may arise from fatigue or ageing must be prevented. Accordingly, operators of series lifting device are obliged to determine the actual utilisation. This determination is easiest using the calculator on our website. The actual utilisation period is recorded as part of the annual inspection by customer service engineers. A general overhaul must be carried out when the theoretical lifetime is reached, or after no more than 10 years. All checking and the general overhaul itself must be arranged by the operator of the lifting device.

The following theoretical utilisation period applies to electric chain hoists that are categorised according to ISO 4301-1 (converted into full-load hours):

M3	M4	M5	M6	M7	M8
400 h	800 h	1600 h	3200 h	6300 h	12500 h

### 4.1 Determining the actual operating time

The actual utilisation period depends on the daily operating time and the load collective. Running time is determined from information provided by the operator or recorded using a meter that counts the number of operating hours. The load collective is determined in accordance with table 1–1, page 11. With these both values, the annual utilisation period can be found in table 4–1. If an operating data acquisition system (BDE) is used, the actual utilisation can be read out directly by our experts during the annual inspection.



The values periodically calculated or read-off are to be recorded in the inspection pass.

Table 4-1 Annual lifetime

Use per day [h]	<= 0.25 (0.16)	<= 0.50 (0.32)	<= 1.0 (0.64)	<= 2.0 (1.28)	<= 4.0 (2.56)	<= 8.0 (5.12)	<= 16.0 (10.24)	> 16.0 (20.48)
Load collective	Annual lifetime [h]							
k = 0.50	6	12	24	48	96	192	384	768
k = 0.63	12	24	48	96	192	384	768	1536
k = 0.80	24	48	96	192	384	768	1536	3072
k = 1.00	48	96	192	384	768	1536	3072	6144

### 4.2 General overhaul

On reaching the theoretical lifetime (no later than 10 years for recording without BDE), a general overhaul should be performed. This enables the equipment to continue operating safely for a further period of use (period of lifetime). Components must be checked or replaced in accordance with table 4–2. The checking and release for the further use must be done by a specialist company authorised by the manufacturer or by the manufacturer himself.

**The inspector determines:**

- what theoretical new use is possible.
- the max. period until the next general overhaul.

This data should be recorded in the inspection pass.

Table 4-2 General overhaul

Components of LP models, all types	Check for wear *	Replace
Brake	x	
Motor shaft	x	
Gear teeth		x
Antifriction bearing		x
Sealings		x
Chain	x **	
Chain wheel, chain guidance	x	
Suspension	x	
Load hook		x
Trolley, load wheel	x	
Contactors, limit switch	x	

\* replace if worn

\*\* replace at the latest in general overhaul

# 5 Appendix

## 5.1 Technical data

Table 5-1 Technical data LP D8

ISO (FEM) classification		M3 (1Bm) 150 s/h, 25 % duty				M4 (1Am) 180 s/h, 30 % duty				M5 (2m) 240 s/h, 40 % duty				Lifting speed 50 Hz	Lifting speed 60 Hz	Motor type	No. of chain falls	Mains fuse (delayed)
Types	Dead weight	Capacity normal hoist	Capacity climbing hoist	Total capacity climbing hoist	Chain security normal/climbing hoist	Capacity normal hoist	Capacity climbing hoist	Total capacity climbing hoist	Chain security normal/climbing hoist	Capacity normal hoist	Capacity climbing hoist	Total capacity climbing hoist	Chain security normal/climbing hoist					
	[kg]	[kg]	[kg]	[kg]		[kg]	[kg]	[kg]		[kg]	[kg]	[kg]		[m/min]	[m/min]			[A]
LP 500/1NL D8	22	800	778	800	5.1	630	608	630	6.4	500	478	500	8.0	4	4.8	80 A 4	1	6
LP 500/1N D8	22	800	778	800	5.1	630	608	630	6.4	500	478	500	8.0	8	9.6	80 B 2	1	6
LP 500/1NF D8	22	800	778	800	5.1	630	608	630	6.4	500	478	500	8.0	8/2	9.6/2.4	80 A 8/2	1	6
LP 500/1NL 1Ph D8	22	-	-	-	-	-	-	-	-	500	478	500	8.0	4	4.8	80 A 4	1	10

Table 5-2 Technical data LP D8 PLUS

ISO (FEM) classification		M5 (2m) 240 s/h, 40 % duty				M3 (1Bm) 150 s/h, 25 % duty				M5 (2m) 240 s/h, 40 % duty				Lifting speed 50 Hz	Lifting speed 60 Hz	Motor type	No. of chain falls	Mains fuse (delayed)
Types	Dead weight	Capacity normal hoist	Capacity climbing hoist	Total capacity climbing hoist	Chain security normal/climbing hoist	Capacity normal hoist	Capacity climbing hoist	Total capacity climbing hoist	Chain security normal/climbing hoist	Capacity normal hoist	Capacity climbing hoist	Total capacity climbing hoist	Chain security normal/climbing hoist					
	[kg]	[kg]	[kg]	[kg]		[kg]	[kg]	[kg]		[kg]	[kg]	[kg]		[m/min]	[m/min]			[A]
LP 500/1NL D8 PLUS	23	500	477	500	8.0	400	377	400	10.0	320	297	320	12.5	4	4.8	80 A 4	1	6
LP 500/1N D8 PLUS	23	500	477	500	8.0	400	377	400	10.0	320	297	320	12.5	8	9.6	80 B 2	1	6
LP 500/1NF D8 PLUS	23	500	477	500	8.0	400	377	400	10.0	320	297	320	12.5	8/2	9.6/2.4	80 A 8/2	1	6
LP 500/1NL 1Ph D8 PLUS	23	500	477	500	8.0	400	377	400	10.0	320	297	320	12.5	4	4.8	80 A 4	1	10

Table 5-3 Technical data LP C1

ISO (FEM) classification		M5 (2m) 240 s/h, 40 % duty				M5 (2m) 240 s/h, 40 % duty				M5 (2m) 240 s/h, 40 % duty				Lifting speed 50 Hz	Lifting speed 60 Hz	Motor type	No. of chain falls	Mains fuse (delayed)
Types	Dead weight	Capacity normal hoist	Capacity climbing hoist	Total capacity climbing hoist	Chain security normal/climbing hoist	Capacity normal hoist	Capacity climbing hoist	Total capacity climbing hoist	Chain security normal/climbing hoist	Capacity normal hoist	Capacity climbing hoist	Total capacity climbing hoist	Chain security normal/climbing hoist					
	[kg]	[kg]	[kg]	[kg]		[kg]	[kg]	[kg]		[kg]	[kg]	[kg]		[m/min]	[m/min]			[A]
LP 500/1NL C1	24	400	376	400	10.0	320	296	320	12.5	250	226	250	16.0	4	4.8	80 A 4	1	6
LP 500/1N C1	24	400	376	400	10.0	320	296	320	12.5	250	226	250	16.0	8	9.6	80 B 2	1	6
LP 500/1NF C1	24	400	376	400	10.0	320	296	320	12.5	250	226	250	16.0	8/2	9.6/2.4	80 A 8/2	1	6



Table 5-4 Technical data LP D8

ISO (FEM) classification		M3 (1Bm) 150 s/h, 25 % duty				M4 (1A) 180 s/h, 30 % duty				M5 (2m) 240 s/h, 40 % duty				Lifting speed 50 Hz	Lifting speed 60 Hz	Motor type	No. of chain falls	Mains fuse (delayed)
Types	Dead weight	Capacity normal hoist	Capacity climbing hoist	Total capacity climbing hoist	Chain security normal/climbing hoist	Capacity normal hoist	Capacity climbing hoist	Total capacity climbing hoist	Chain security normal/climbing hoist	Capacity normal hoist	Capacity climbing hoist	Total capacity climbing hoist	Chain security normal/climbing hoist					
	[kg]	[kg]	[kg]	[kg]		[kg]	[kg]	[kg]		[kg]	[kg]	[kg]						
LP 1000/1NL D8	56	1600	1544	1600	5.1	1250	1194	1250	6.4	1000	944	1000	8.0	4	4.8	90 B 4	1	10
LP 1000/1N D8	56	1600	1544	1600	5.1	1250	1194	1250	6.4	1000	944	1000	8.0	8	9.6	90 B 2	1	10
LP 1000/1NF D8	56	1600	1544	1600	5.1	1250	1194	1250	6.4	1000	944	1000	8.0	8/2	9.6/2.4	100 B 8/2	1	10

Table 5-5 Technical data LP D8 PLUS

ISO (FEM) classification		M5 (2m) 240 s/h, 40 % duty				M6 (3m) 300 s/h, 50 % duty				M7 (4m) 360 s/h, 60 % duty				Lifting speed 50 Hz	Lifting speed 60 Hz	Motor type	No. of chain falls	Mains fuse (delayed)
Types	Dead weight	Capacity normal hoist	Capacity climbing hoist	Total capacity climbing hoist	Chain security normal/climbing hoist	Capacity normal hoist	Capacity climbing hoist	Total capacity climbing hoist	Chain security normal/climbing hoist	Capacity normal hoist	Capacity climbing hoist	Total capacity climbing hoist	Chain security normal/climbing hoist					
	[kg]	[kg]	[kg]	[kg]		[kg]	[kg]	[kg]		[kg]	[kg]	[kg]						
LP 1000/1NL D8 PLUS	58	1000	942	1000	8.0	800	742	800	10.0	630	572	630	12.5	4	4.8	90 B 4	1	10
LP 1000/1N D8 PLUS	58	1000	942	1000	8.0	800	742	800	10.0	630	572	630	12.5	8	9.6	90 B 2	1	10
LP 1000/1NF D8 PLUS	58	1000	942	1000	8.0	800	742	800	10.0	630	572	630	12.5	8/2	9.6/2.4	100 B 8/2	1	10

Table 5-6 Technical data LP C1

ISO (FEM) classification		M6 (3m) 300 s/h, 50 % duty				M7 (4m) 360 s/h, 60 % duty				Lifting speed 50 Hz	Lifting speed 60 Hz	Motor type	No. of chain falls	Mains fuse (delayed)			
Types	Dead weight	Capacity normal hoist	Capacity climbing hoist	Total capacity climbing hoist	Chain security normal/climbing hoist	Capacity normal hoist	Capacity climbing hoist	Total capacity climbing hoist	Chain security normal/climbing hoist						[m/min]	[m/min]	[A]
	[kg]	[kg]	[kg]	[kg]		[kg]	[kg]	[kg]									
LP 1000/1NL C1	59	800	741	800	10.0	630	571	630	12.5				4	4.8	90 B 4	1	10
LP 1000/1N C1	59	800	741	800	10.0	630	571	630	12.5				8	9.6	90 B 2	1	10



Table 5-8 Electrical parameters LP (three-phase version)

Types	Motor type	No. of poles	P <sub>N</sub> [kW]	n <sub>N</sub> [1/min]	min. / max. currents and start-up current														
					3 x 400 V, 50 Hz					3 x 230 V, 50 Hz									
					I <sub>N460</sub> [A]	I <sub>N480</sub> [A]	I <sub>max.</sub> [A]	I <sub>A</sub> /I <sub>N480</sub>	cos phi <sub>N</sub>	I <sub>N220</sub> [A]	I <sub>N240</sub> [A]	I <sub>max.</sub> [A]	I <sub>A</sub> /I <sub>N240</sub>	cos phi <sub>N</sub>					
LP 500	80 B 8/2	8	0.18	665	1.4	1.9	2.2	1.45	0.51	2.4	3.1	3.5	1.45	0.51					
		2	0.72	2745	2.4	3.4	3.7	2.75	0.77	3.2	4.3	4.7	2.75	0.77					

Table 5-9 Electrical parameters LP (three-phase version)

Types	Motor type	No. of poles	P <sub>N</sub> [kW]	n <sub>N</sub> [1/min]	min. / max. currents and start-up current														
					3 x 460 V, 60 Hz					3 x 380 V, 60 Hz									
					I <sub>N460</sub> [A]	I <sub>N480</sub> [A]	I <sub>max.</sub> [A]	I <sub>A</sub> /I <sub>N480</sub>	cos phi <sub>N</sub>	I <sub>N380</sub> [A]		I <sub>max.</sub> [A]	I <sub>A</sub> /I <sub>N380</sub>	cos phi <sub>N</sub>					
LP 500	80 B 8/2	8	0.22	815	1.2	1.5	1.9	1.45	0.50	1.9		2.3	1.45	0.50					
		2	0.86	3345	2.3	2.8	3.2	2.75	0.76	2.8		3.5	2.75	0.76					

Table 5-13 Electrical parameters LP (three-phase version)

Types	Motor type	No. of poles	P <sub>N</sub> [kW]	n <sub>N</sub> [1/min]	min. / max. currents and start-up current													
					3 x 400 V, 50 Hz					3 x 230 V, 50 Hz								
					I <sub>N 380</sub> [A]	I <sub>N 415</sub> [A]	I <sub>max.</sub> [A]	I <sub>A</sub> /I <sub>N 415</sub>	cos phi <sub>N</sub>	I <sub>N 220</sub> [A]	I <sub>N 240</sub> [A]	I <sub>max.</sub> [A]	I <sub>A</sub> /I <sub>N 240</sub>	cos phi <sub>N</sub>				
LP 1000	90 B 4	4	1.50	1430	3.1	3.6	4.2	1.65	0.76	-	-	-	1.65	0.76				

Table 5-14 Electrical parameters LP (three-phase version)

Types	Motor type	No. of poles	P <sub>N</sub> [kW]	n <sub>N</sub> [1/min]	min. / max. currents and start-up current													
					3 x 460 V, 60 Hz					3 x 380 V, 60 Hz					3 x 208-230/460 V, 60 Hz			
					I <sub>N 460</sub> [A]	I <sub>N 480</sub> [A]	I <sub>max.</sub> [A]	I <sub>A</sub> /I <sub>N 480</sub>	cos phi <sub>N</sub>	I <sub>N 380</sub> [A]	I <sub>max.</sub> [A]	I <sub>A</sub> /I <sub>N 380</sub>	cos phi <sub>N</sub>	I <sub>N 208</sub> [A]	I <sub>N 460</sub> [A]	I <sub>max.</sub> [A]	I <sub>A</sub> /I <sub>N 460</sub>	cos phi <sub>N</sub>
LP 1000	90 B 4	4	1.80	1730	3.1	3.6	4.2	1.65	0.75	-	-	1.65	0.75	3.7	1.9	4.7	1.65	0.75

Table 5-15 Electrical parameters LP (three-phase version)

Types	Motor type	No. of poles	P <sub>N</sub> [kW]	n <sub>N</sub> [1/min]	min. / max. currents and start-up current													
					3 x 400 V, 50 Hz					3 x 230 V, 50 Hz								
					I <sub>N 380</sub> [A]	I <sub>N 415</sub> [A]	I <sub>max.</sub> [A]	I <sub>A</sub> /I <sub>N 415</sub>	cos phi <sub>N</sub>	I <sub>N 220</sub> [A]	I <sub>N 240</sub> [A]	I <sub>max.</sub> [A]	I <sub>A</sub> /I <sub>N 240</sub>	cos phi <sub>N</sub>				
LP 1000	90 B 2	2	2.30	2745	-	-	-	1.65	0.68	-	-	-	1.65	0.68				

Table 5-16 Electrical parameters LP (three-phase version)

Types	Motor type	No. of poles	P <sub>N</sub> [kW]	n <sub>N</sub> [1/min]	min. / max. currents and start-up current													
					3 x 460 V, 60 Hz					3 x 380 V, 60 Hz					3 x 208-230/460 V, 60 Hz			
					I <sub>N 460</sub> [A]	I <sub>N 480</sub> [A]	I <sub>max.</sub> [A]	I <sub>A</sub> /I <sub>N 480</sub>	cos phi <sub>N</sub>	I <sub>N 380</sub> [A]	I <sub>max.</sub> [A]	I <sub>A</sub> /I <sub>N 380</sub>	cos phi <sub>N</sub>	I <sub>N 208</sub> [A]	I <sub>N 460</sub> [A]	I <sub>max.</sub> [A]	I <sub>A</sub> /I <sub>N 460</sub>	cos phi <sub>N</sub>
LP 1000	90 B 2	2	2.76	3345	-	-	-	1.65	0.67	-	-	1.65	0.67	3.7	1.9	4.7	1.65	0.67

Table 5-17 Electrical parameters LP (three-phase version)

Types	Motor type	No. of poles	P <sub>N</sub> [kW]	n <sub>N</sub> [1/min]	min. / max. currents and start-up current														
					3 x 400 V, 50 Hz					3 x 230 V, 50 Hz									
					I <sub>N 380</sub> [A]	I <sub>N 415</sub> [A]	I <sub>max.</sub> [A]	I <sub>A</sub> /I <sub>N 415</sub>	cos phi <sub>N</sub>	I <sub>N 220</sub> [A]	I <sub>N 240</sub> [A]	I <sub>max.</sub> [A]	I <sub>A</sub> /I <sub>N 240</sub>	cos phi <sub>N</sub>					
LP 1000	100 B 8/2	8	0.57	675	3.8	4.3	5.1	1.45	0.58	7.1	7.4	9.0	1.45	0.58					
		2	2.30	2790	5.3	6.2	7.8	2.75	0.77	8.2	9.3	10.7	2.75	0.77					

Table 5-18 Electrical parameters LP (three-phase version)

Types	Motor type	No. of poles	P <sub>N</sub> [kW]	n <sub>N</sub> [1/min]	min. / max. currents and start-up current														
					3 x 460 V, 60 Hz					3 x 380 V, 60 Hz									
					I <sub>N 460</sub> [A]	I <sub>N 480</sub> [A]	I <sub>max.</sub> [A]	I <sub>A</sub> /I <sub>N 480</sub>	cos phi <sub>N</sub>	I <sub>N 380</sub> [A]		I <sub>max.</sub> [A]	I <sub>A</sub> /I <sub>N 380</sub>	cos phi <sub>N</sub>					
LP 1000	100 B 8/2	8	0.69	825	3.8	4.1	4.7	1.65	0.57	-		-	1.65	0.57					
		2	2.80	3390	5.3	5.8	7.3	2.75	0.76	-		-	2.75	0.76					

### 5.3 EC Declaration of conformity

Declaration for a machinery according to the EU directives 2006/42/EC, Annex II A, 2014/30/EU, Annex I and 2014/35/EU, Annex III



Hereby we,

**GIS AG, Swiss Lifting Solutions, Luzernerstrasse 50, CH-6247 Schötz**

declare that the machinery

**GIS electric chain hoist, series  
with a load capacity of  
serial number range**

**LP  
250 kg to 1600 kg  
1000001 to 1010000**

developed for lifting and lowering loads, is, in standard production and from the 2016 model year, inclusive of load control, meets the essential requirements of the following EC directives, as applicable to the scope of the delivery:

EC Machinery Directive	2006/42/EC
EC Directive on Electromagnetic Compatibility	2014/30/EU
EC Low Voltage Directive	2014/35/EU

**Harmonized standards applied:**

ISO 2374	Lifting appliances; Range of maximum capacities for basic models
DIN EN 818-7	Short link chain for lifting purposes; Part 7: Grade T
DIN EN ISO 13849-1	Safety-related parts of control systems; Part 1: General principles for design
DIN EN 14492-2	Cranes, power driven winches and hoists; Part 2: Power driven hoists
DIN EN 60204-32	Electrical equipment of machines; Part 32: Requirements for hoisting machines

**Standards and technical specifications applied:**

FEM 9.751	Power driven lifting device series; safety
FEM 9.755	Measure for achieving safe working periods
DIN 56950	Event technology
IGVW SQ P2	Standards for event technology

Authorized to compile relevant technical documentation:  
GIS AG, Luzernerstrasse 50, CH-6247 Schötz

Schötz, 15.09.2016

**GIS AG**

I. Muri  
Director

E. Widmer  
Sales manager

The completion, installation and start-up as per instruction manual is documented in the log book.

## 5.4 EC Declaration of incorporation

Declaration for the incorporation of a partly completed machinery according to the EU directives 2006/42/EC, Annex II B, 2014/30/EU, Annex I and 2014/35/EU, Annex III



Hereby we,

**GIS AG, Swiss Lifting Solutions, Luzernerstrasse 50, CH-6247 Schötz**

declare that the partly completed machinery

<b>GIS electric chain hoist, series</b>	<b>LP</b>
<b>with a load capacity of</b>	<b>250 kg to 1600 kg</b>
<b>serial number range</b>	<b>1000001 to 1010000</b>

developed for lifting and lowering loads, is, in standard production and from the 2016 model year, inclusive of load control, intended for installation in machinery and meets the essential requirements of the following EC directives, as applicable to the scope of the delivery:

EC Machinery Directive	2006/42/EC
EC Directive on Electromagnetic Compatibility	2014/30/EU
EC Low Voltage Directive	2014/35/EU

We also declare that the technical documentation has been compiled in accordance with Annex VII, Part B of Directive 2006/42/EC. We undertake to submit the specific documents relating to the lifting device to national authorities on receipt of a reasonable request. The information will be supplied by electronic means.

**Harmonized standards applied:**

ISO 2374	Lifting appliances; Range of maximum capacities for basic models
DIN EN 818-7	Short link chain for lifting purposes; Part 7: Grade T
DIN EN ISO 13849-1	Safety-related parts of control systems; Part 1: General principles for design
DIN EN 14492-2	Cranes, power driven winches and hoists; Part 2: Power driven hoists
DIN EN 60204-32	Electrical equipment of machines; Part 32: Requirements for hoisting machines

**Standards and technical specifications applied:**

FEM 9.751	Power driven lifting device series; safety
FEM 9.755	Measure for achieving safe working periods
DIN 56950	Event technology
IGVW SQ P2	Standards for event technology

**This declaration only refers to the lifting device. A start-up is prohibited until it has been proven that the entire system where the lifting device is built in corresponds with the above EC Directives.**

Authorized to compile relevant technical documentation:  
GIS AG, Luzernerstrasse 50, CH-6247 Schötz

Schötz, 15.09.2016

**GIS AG**



I. Muri  
Director



E. Widmer  
Sales Manager

The completion, installation and start-up as per instruction manual is documented in the log book.

