

ELECTRIC PILE WIND WINCHES



The Pilewind Winch is a staple of theatres and performance venues around the world. A multipurpose winch unit, designed to provide a basic electric hoisting system for use with suspension bars and trussing applications, these units are a good solution for educational establishments, places of worship, studio spaces and smaller theatrical venues.

- » Standard lifting capacity 250, 500 or 1000kg
- » Winches 3-6 lines per hoist
- » Power 400V, 3 Ph, 50 Hz
- » Self- sustaining gearbox
- » Single or double brake with manual lever release
- » Standard winch travel 12m
- » End of travel and ultimate limits as standard
- » CE certified

OPTIONS

- » Local control panel mounted on winch
- » Encoders
- » Wire rope pulleys (see separate datasheet for options)
- » Wire ropes can be provided on request

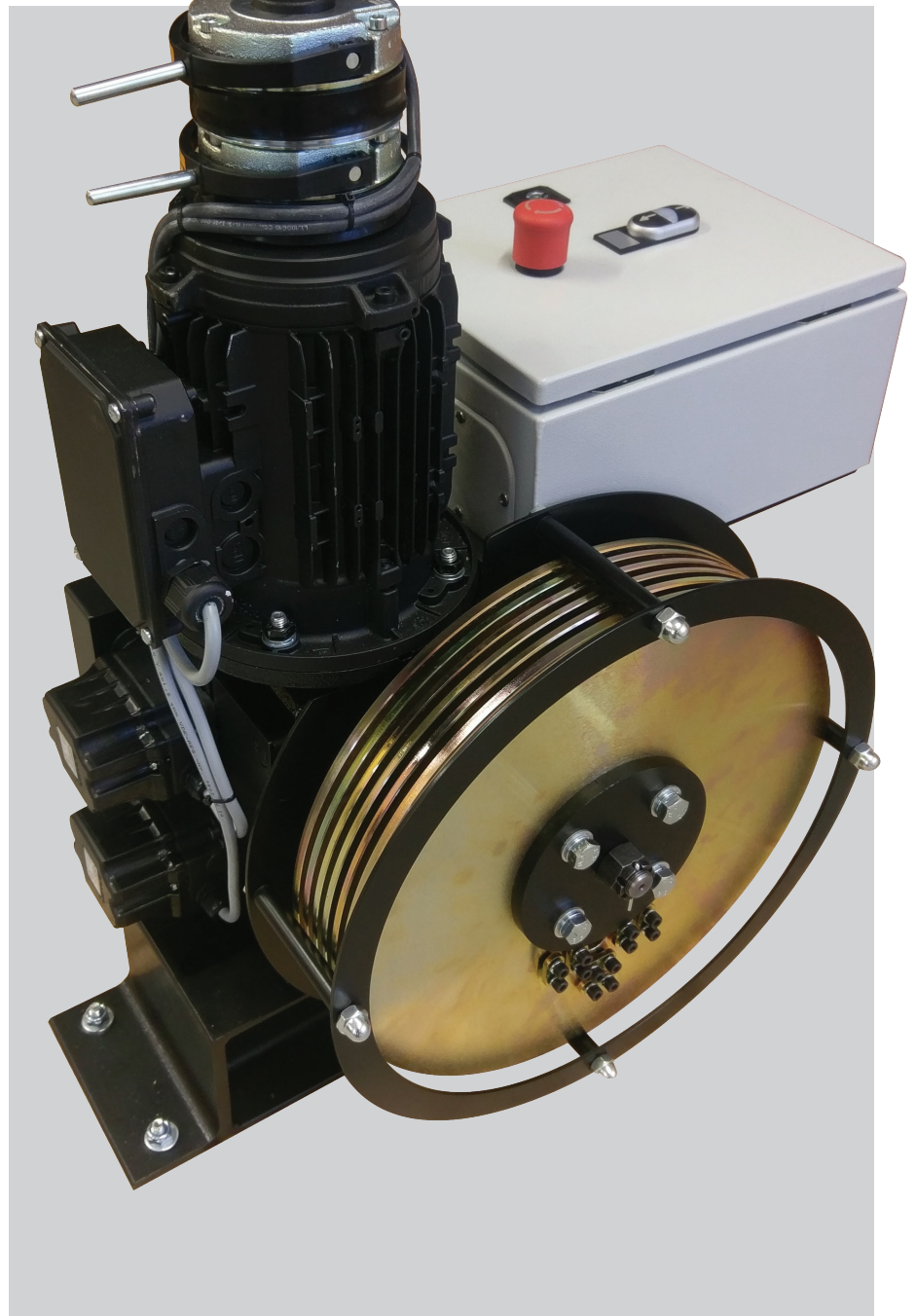

SPECIFICATIONS

WINCH TYPE	LIFTING CAPACITY (kg)	NO OF ROPES	ROPE DIA (mm)	SPEED (m/sec)	MOTOR POWER (kW)	WEIGHT OF WINCH (kg)
WIN-250-3	250	3	5	0.15-0.3	1.1	145
WIN-250-4	250	4	5	0.15-0.3	1.1	152
WIN-250-5	250	5	5	0.15-0.3	1.1	159
WIN-250-6	250	6	5	0.15-0.3	1.1	166
WIN-500-3	500	3	6	0.15-0.3	2.2	170
WIN-500-4	500	4	6	0.15-0.3	2.2	177
WIN-500-5	500	5	6	0.15-0.3	2.2	184
WIN-500-6	500	6	6	0.15-0.3	2.2	191
WIN-1000-3	1000	3	6	0.04-0.07	1.5	197
WIN-1000-4	1000	4	6	0.04-0.07	1.5	204
WIN-1000-5	1000	5	6	0.04-0.07	1.5	213
WIN-1000-6	1000	6	6	0.04-0.07	1.5	220

PILE WIND WINCHES



250/500KG WINCHES

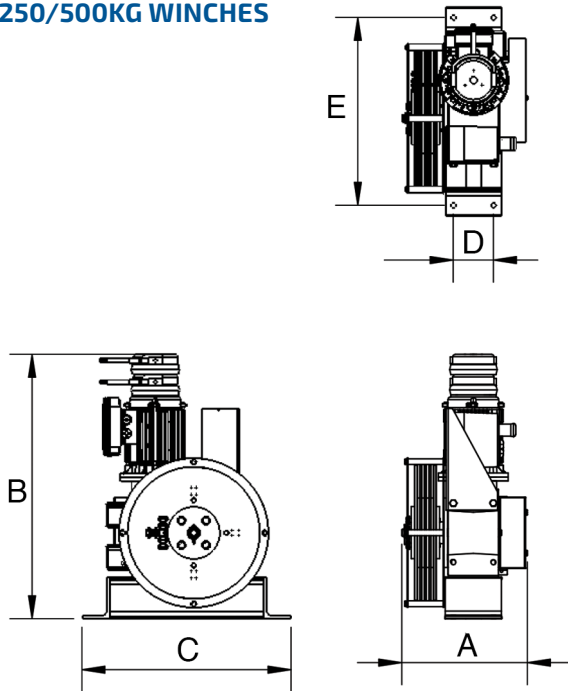

1000KG WINCH

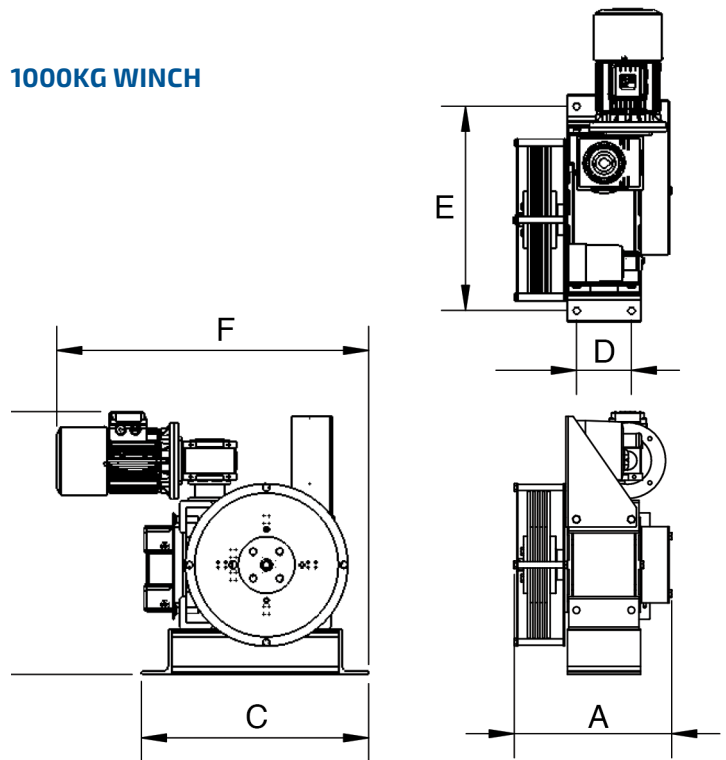

DIMENSIONS (mm)

WINCH TYPE	LIFTING CAPACITY (kg)	NO OF ROPES	A (mm)	B-SINGLE BRAKE (mm)	B-DOUBLE BRAKE (mm)	C (mm)	D (mm)	E (mm)	F-SINGLE BRAKE (mm)	F-DOUBLE BRAKE (mm)
WIN-250-3	250	3	348	718	760	600	115	540	n/a	n/a
WIN-250-4	250	4	360	718	760	600	115	540	n/a	n/a
WIN-250-5	250	5	373	718	760	600	115	540	n/a	n/a
WIN-250-6	250	6	385	718	760	600	115	540	n/a	n/a
WIN-500-3	500	3	376	825	845	600	120	540	n/a	n/a
WIN-500-4	500	4	389	825	845	600	120	540	n/a	n/a
WIN-500-5	500	5	402	825	845	600	120	540	n/a	n/a
WIN-500-6	500	6	414	825	845	600	120	540	n/a	n/a
WIN-1000-3	1000	3	404	695	725	600	145	540	824	868
WIN-1000-4	1000	4	417	695	725	600	145	540	824	868
WIN-1000-5	1000	5	429	695	725	600	145	540	824	868
WIN-1000-6	1000	6	442	695	725	600	145	540	824	868

COMPANY CONTACT DETAILS

LTM - Lift Turn Move Ltd
 Unit 2 Stadium Court
 Wirral International Business Park
 Plantation Road, Bromborough
 Wirral, UK CH62 3QG

SALES AND GENERAL CONTACTS

Tel: +44 (0)151 649 0467
 Fax: +44 (0)151 649 0099
 Email: sales@LiftTurnMove.co.uk
 Email: accounts@LiftTurnMove.co.uk
 Website: www.liftturnmove.co.uk

OPENING HOURS

Mon-Thur: 8:30 - 5:00
 Friday: 8:30 - 2:30

The office is often open outside these times.

DELIVERIES

We use various methods of delivery and can deliver more or less whenever you need.

To stay up to date with the latest events at LTM please follow us on Facebook, Twitter and LinkedIn



[liftturnmove](https://www.facebook.com/liftturnmove)



[@LiftTurnMove](https://twitter.com/LiftTurnMove)



[@Lift Turn Move Ltd](https://www.linkedin.com/company/liftturnmove)