

MINI POWERED PILE WIND WINCH

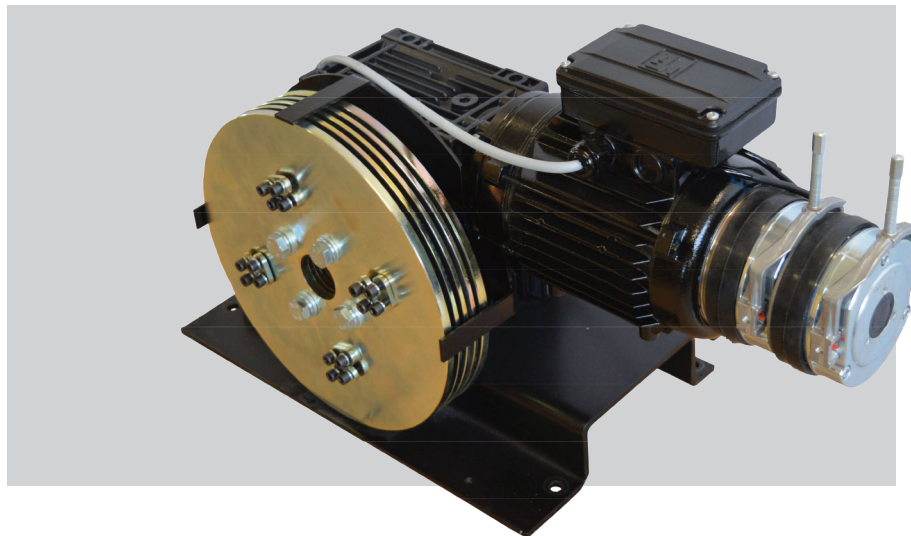

- » Standard lifting capacity 150 kg
- » 1 - 4 lines per hoist
- » Diameter of wire - 4mm
- » Rope keeps
- » Power 400V, 3Ph, 50 Hz, 0.75Kw
- » Self sustaining gearbox
- » Double brake with manual lever release
- » Standard winch travel - 9m
- » 3600 spool access
- » Local control - up/down, e-stop
- » Limit switches - 'absolute' and 'travel'
- » Floor, wall or ceiling mounting
- » CE certified



OPTIONS

- » Different lifting speed
- » Soft start/stop, variable speed
- » No local control (terminal connectors)
- » Encoder
- » Overload/underload sensing by separate load pulley unit
- » Motor overheat sensor
- » Brake release sensors

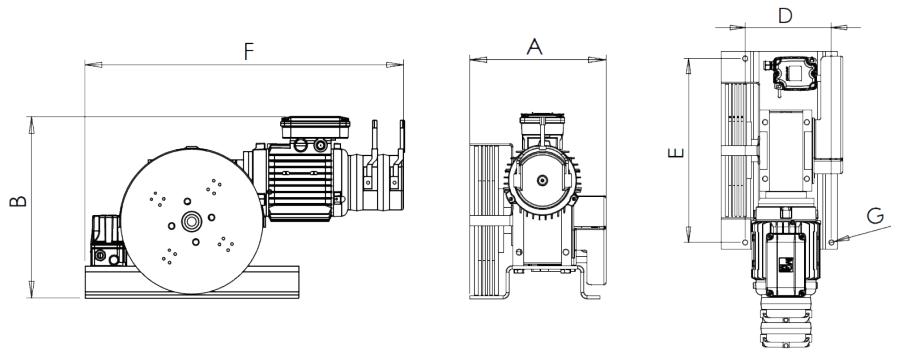

SPECIFICATIONS

WINCH TYPE	LIFTING CAPACITY (kg)	NO. OF ROPES	ROPE DIAMETER (mm)	BRAKES	SPEED	MOTOR POWER (kW)	WEIGHT (kg)
WIN-150-1D-K	150	1	4	Double	0.22 - 0.35	0.75	41
WIN-150-2D-K	150	2	4	Double	0.22 - 0.35	0.75	44
WIN-150-3D-K	150	3	4	Double	0.22 - 0.35	0.75	47
WIN-150-4D-K	150	4	4	Double	0.22 - 0.35	0.75	50

DIMENSIONS

WINCH TYPE	LIFTING CAPACITY (kg)	NO. OF ROPES	A (mm)	B (mm)	D (mm)	E (mm)	F (mm)	G (mm)
WIN-150-1D-K	150	1	262	351	186	390	626	10.5
WIN-150-2D-K	150	2	262	351	186	390	626	10.5
WIN-150-3D-K	150	3	262	351	186	390	626	10.5
WIN-150-4D-K	150	4	262	351	186	390	626	10.5

COMPANY CONTACT DETAILS

LTM - Lift Turn Move Ltd
 Unit 2 Stadium Court
 Wirral International Business Park
 Plantation Road, Bromborough
 Wirral, UK CH62 3QG

SALES AND GENERAL CONTACTS

Tel: +44 (0)151 649 0467
 Fax: +44 (0)151 649 0099
 Email: sales@LiftTurnMove.co.uk
 Email: accounts@LiftTurnMove.co.uk
 Website: www.liftturnmove.co.uk

OPENING HOURS

Mon-Thur: 8:30 - 5:00
 Friday: 8:30 - 2:30

The office is often open outside these times.

DELIVERIES

We use various methods of delivery and can deliver more or less whenever you need.

To stay up to date with the latest events at LTM please follow us on Facebook, Twitter and LinkedIn



[liftturnmove](https://www.facebook.com/liftturnmove)



[@LiftTurnMove](https://twitter.com/LiftTurnMove)



[@Lift Turn Move Ltd](https://www.linkedin.com/company/liftturnmove)