

LP D8+ ENTERTAINMENT CHAIN HOISTS

FOR GENERAL RIGGING PURPOSES TO D8 PLUS GUIDELINES

MAX LIFTING CAPACITY/SWL 125KG – 2000KG

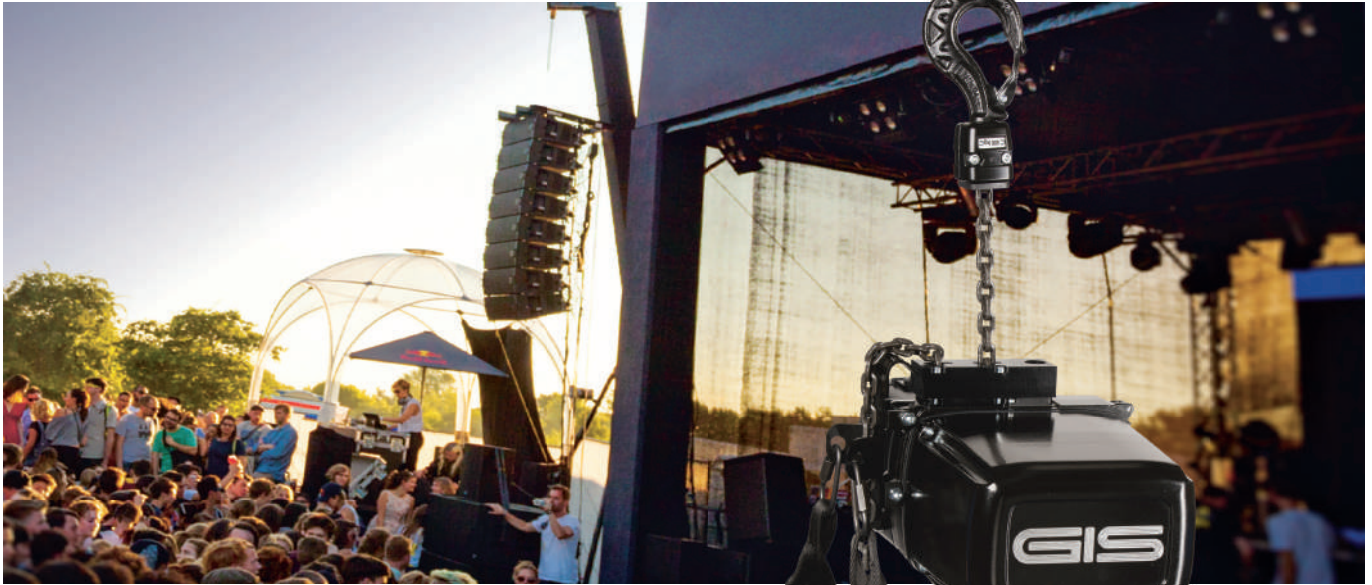

THE REGULATIONS

High integrity hoists prepared for incorporation into D8PLUS hoisting systems to enable hoists to be used with the capability of holding loads at rest above people without using a secondary safety component, to accepted standards and codes of practice

These hoists enable

(when people are below the load):
Load holding when loads are static

The hoists do not enable

(when people are below the load):
Assembly/disassembly during set up
Staging processes involving movement

D8PLUS FEATURES INCLUDE:

- » Second brake
- » De-rating of the lifting capacity to give an increase safety factor of at least 8:1 according to DIN56950-1 or IGWW SQ P2
- » Clutch overload device is mounted outside the drive train; In the event of clutch problems, the load is not compromised

FEATURES - GENERAL

- » Modern, quiet, reliable and proven design, manufacture and assembly mean long life and competitive pricing
- » Lightweight hoists, with the smallest model weighing only 13kg
- » Max Lifting Capacity/SWL from 125 to 2000kg
- » 2 independent spring loaded brakes
- » Direct control or low voltage control – With upper/lower geared electrical limit switches
- » Contactor control - no electronics
- » Clutch overload device mounted outside the drive train; in the event of clutch problems, the load is not compromised
- » Can be used upright - motor up or climbing - motor down
- » Aluminium body - black electrophoretic coated
- » Eye body suspension is standard, hook suspension and locking chain hooks on request
- » Available for 400V, 3Ph, or 220V, 1Ph power, others on request

**FOR WHEN YOU NEED TO
LIFT, LOWER, POSITION
OR SUSPEND A LOAD IN
ENTERTAINMENT RIGGING
APPLICATIONS**

FEATURES - NEW LP/LPM HOIST

- » A new hoist from LTM
- » Designed with higher lifting capacities at D8PLUS with higher duty and longer lifetime hours
- » IP65 Protection class - ideal for outside use, the moisture sensitive components are housed separately and sealed
- » NEW Profile (square) steel lifting chain carries heavier loads with lower wear, black phosphate protection with high corrosion resistance and increased service life
- » Polygon connections on shafts and hubs - easier maintenance
- » Simple, reliable, easy to use and maintain
- » Hoist can be set to D8+ accordingly to DIN56950 8:1 or IGWW SQ P2 8:1

OPTIONS

- » Extra features allow the hoist to conform to higher safety standards with order or when later modified
- » Options include standard and ultimate limit switches, load sensing suspensions or encoders for positional feedback
- » Hoists for single phase power
- » Locking hooks
- » Flight cases
- » Other features on request, ask our sales team for details
- » Custom cable tails to meet most control systems

LP D8+ ENTERTAINMENT CHAIN HOISTS

FOR GENERAL RIGGING PURPOSES TO D8 PLUS GUIDELINES

MAX LIFTING CAPACITY/SWL 125KG – 2000KG



SPECIFICATIONS

HOIST TYPE	MAX LIFTING CAPACITY/ SWL	NOMINAL LIFTING SPEED	NO. OF CHAIN FALLS	MOTOR POWER	POWER CONSUMPTION LOADED	CHAIN DIMENSIONS	SOUND PRESSURE LEVEL IN HALL AT 1M DISTANCE	CHAIN SAFETY FACTOR	PROTECTION CLASS	WEIGHT HOIST ONLY	WEIGHT PER METRE LIFT
	(kg)	(m/min)		(kW)	(A)	(mm)	dB			(kg)	(kg)
LPM250/1NL. D8 PLUS	250	4	1	0.25	1.8	3.75 x 10.75	65	8	IP65	13	0.34
LPM250/1SL. D8 PLUS	125	8	1	0.25	1.8	3.75 x 10.75	65	8	IP65	13	0.34
LP500/1NL. D8 PLUS	500	4	1	0.55	1.8	5.25 x 15	65	8	IP65	23	0.69
LP500/1N. D8 PLUS	500	8	1	0.72	2.8	5.25 x 15	65	8	IP65	23	0.69
LP500/1NF. D8 PLUS	500	8/2	1	0.72/0.18	2.8/1.7	5.25 x 15	65	8	IP65	23	0.69
LP500/2N. D8 PLUS	1000	4	2	0.72	2.8	5.25 x 15	65	8	IP65	23	0.69
LP500/2NF. D8 PLUS	1000	4/1	2	0.72/0.18	2.8/1.7	5.25 x 15	65	8	IP65	23	0.69
LP1000/1NL.D8 PLUS	1000	4	1	1.5	3.6	7.45 x 23	75	8	IP65	47	1.37
LP1000/1N.D8 PLUS	1000	8	1	2.3	6.5	7.45 x 23	75	8	IP65	51	1.37
LP1000/1NF.D8 PLUS	1000	8/2	1	2.30/0.68	5.7/4.1	7.45 x 23	75	8	IP65	51	1.37

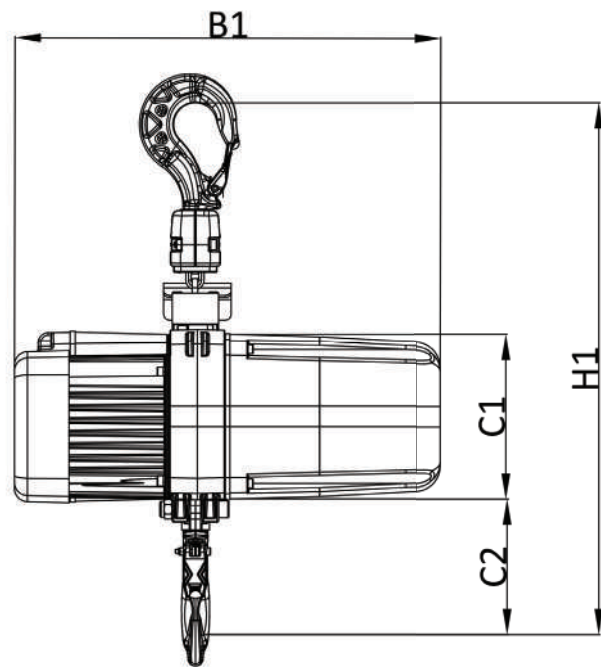
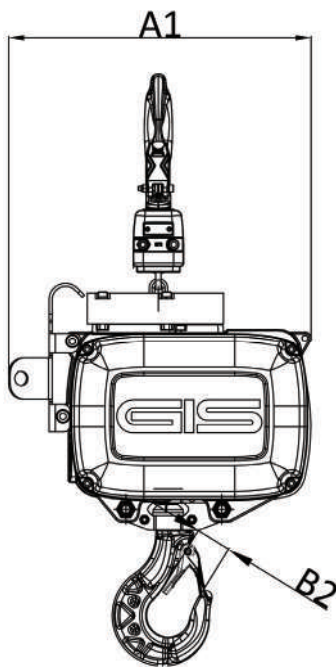

DIMENSIONS

TYPE	NUMBER OF FALLS	A1	B1	B2	C1	C2	H1
LPM250 / D8 PLUS	1	205	389	20	133	96	394
LP500 / D8 PLUS	1	293	414	24	160	132	516
LP1000 / D8 PLUS	1	374	514	28	212	133	619

Dimensions of 2 fall hoists on demand
Drawings available on request

COMPANY CONTACT DETAILS

LTM - Lift Turn Move Ltd
Unit 2 Stadium Court
Wirral International Business Park
Plantation Road, Bromborough
Wirral, UK CH62 3QG

SALES AND GENERAL CONTACTS

Tel: +44 (0)151 649 0467
Fax: +44 (0)151 649 0099
Email: sales@LiftTurnMove.co.uk
Email: accounts@LiftTurnMove.co.uk
Website: www.liftturnmove.co.uk

OPENING HOURS

Mon-Thur: 8:30 - 5:00
Friday: 8:30 - 2:30

The office is often open outside these times.

DELIVERIES

We use various methods of delivery and can deliver more or less whenever you need.

To stay up to date with the latest events at LTM please follow us on Facebook, Twitter and LinkedIn



[liftturnmove](https://www.facebook.com/liftturnmove)



[@LiftTurnMove](https://twitter.com/LiftTurnMove)



[@Lift Turn Move Ltd](https://www.linkedin.com/company/liftturnmove)