

# LG D8+ ENTERTAINMENT CHAIN HOISTS

FOR GENERAL RIGGING PURPOSES TO D8 PLUS GUIDELINES

– MAX LIFTING CAPACITY/SWL 630KG – 2000KG

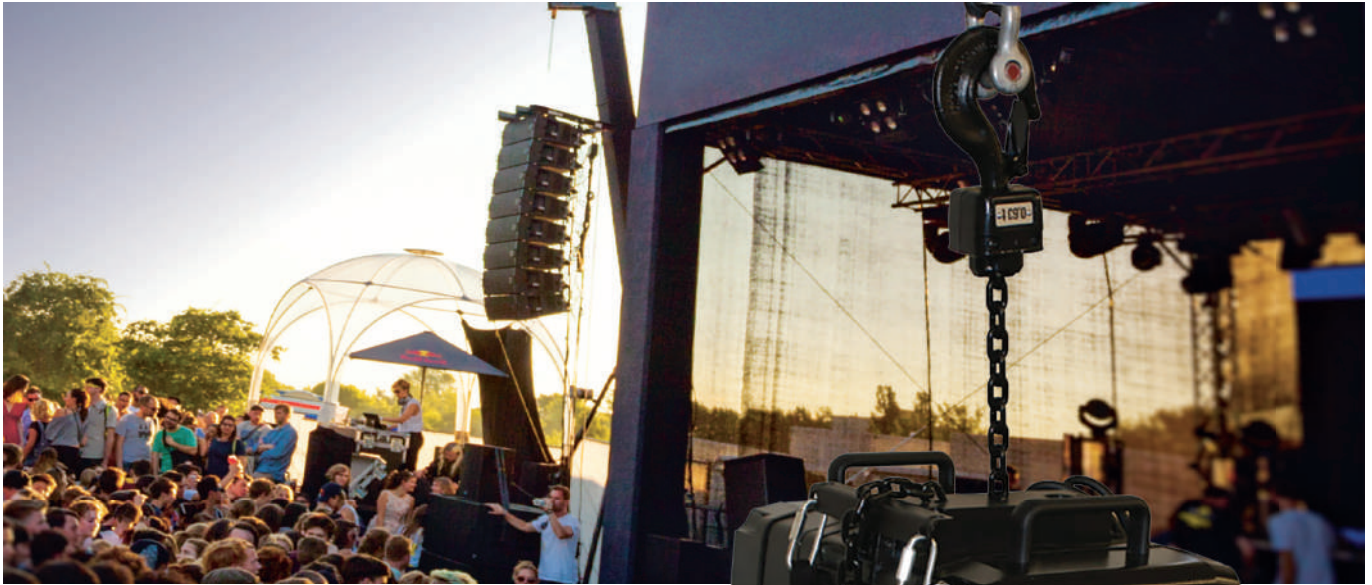

## THE REGULATIONS

High Integrity Hoists prepared for incorporation into D8PLUS hoisting systems to enable hoist to be used with the capability of holding loads at rest above people without using a secondary safety component, to accepted standards and codes of practice.

### These hoists allow the following

(when people are below the load):  
Load holding when loads are static

### The hoists do not allow

(when people are below the load):  
Assembly/disassembly during set up  
Staging processes involving movement

## D8PLUS REQUIRES

- » Second brake
- » De-rating of the lifting capacity to give an increased safety factor. LG Hoists are De-rated to 10:1 in accordance with BGV D8+ requirements
- » Clutch overload device is mounted outside the drive train; In the event of clutch problems, the load is not compromised

## FEATURES - GENERAL

- » Modern, quiet, reliable and proven design, manufacture and assembly mean long life and competitive pricing
- » Lightweight
- » Max Lifting Capacity/SWL from 630 to 2000kg
- » 2 independent spring loaded brakes
- » Direct control or low voltage control - with upper/lower geared electrical limit switches
- » Contactor control - no electronics
- » Clutch overload device mounted outside the drive train; in the event of clutch problems, the load is not compromised
- » Can be used upright - motor up or climbing - motor down
- » Aluminium body - black electrophoretic coated with zinc plated or black chain
- » Eye body suspension is standard, hook suspension and locking chain hooks on request
- » Available for 400V, 3Ph, or 220V, 1Ph power, others on request



**FOR WHEN YOU NEED TO  
LIFT, LOWER, POSITION  
OR SUSPEND A LOAD IN  
ENTERTAINMENT RIGGING  
APPLICATIONS**

## OPTIONS

- » Extra features allow the hoist to conform to higher safety standards with order or when later modified
- » These options include standard and ultimate limit switches, load sensing suspensions or encoders for positional feedback
- » Hoists for single phase power
- » Locking hooks
- » Flight cases

# LG D8+ ENTERTAINMENT CHAIN HOISTS

FOR GENERAL RIGGING PURPOSES TO D8 PLUS GUIDELINES

– MAX LIFTING CAPACITY/SWL 630KG – 2000KG



## SPECIFICATIONS

HOIST TYPE	MAX LIFTING CAPACITY/ SWL	NOMINAL LIFTING SPEED	NO. OF CHAIN FALLS	MOTOR POWER	POWER CONSUMPTION LOADED	CHAIN DIMENSIONS	SOUND PRESSURE LEVEL IN HALL AT 1M DISTANCE	CHAIN SAFETY FACTOR	PROTECTION CLASS	WEIGHT HOIST ONLY	WEIGHT PER METRE LIFT
	(kg)	(m/min)		(kW)	(A)	(mm)	dB			(kg)	(kg)
LG10/1/4D8+	630	4	1	0.46	3.5	7 x 22	72	10	IP55	44	1.04
LG10/1/8D8+	630	8	1	0.91	4.3	7 x 22	72	10	IP55	44	1.04
LG10/1/82D8+	630	8/ 2	1	0.91/ 0.23	4.3/ 3.8	7 x 22	72	10	IP55	44	1.04
LG10/1/164D8+	630	16/ 4	1	5.8/ 2.6	6.5/ 5.8	7 x 22	72	10	IP55	44	1.04
LG10/2/4D8+	1260	4	2	0.46	4.3	7 x 22	72	10	IP55	46	2.08
LG10/2/41D8+	1260	4/ 1	2	0.91/ 0.23	4.3/ 3.8	7 x 22	72	10	IP55	46	2.08
LG10/2/82D8+	1260	8/ 2	2	5.8/ 2.6	6.5/ 5.8	7 x 22	72	10	IP55	46	2.08
LG16/1/4D8+	1000	4	1	0.76	4.5	9 x 27	75	10	IP55	60	1.75
LG16/1/8D8+	1000	8	1	1.53	6.8	9 x 27	75	10	IP55	60	1.75
LG16/1/82D8+	1000	8/ 2	1	1.53/ 0.38	7.3/ 6.2	9 x 27	75	10	IP55	62	1.75
LG16/2/4D8+	1600	4	2	1.53	6.8	9 x 27	75	10	IP55	60	3.5
LG16/2/41D8+	1600	4/ 1	2	1.53/ 0.38	7.3/ 6.2	9 x 27	75	10	IP55	62	3.5
LG20/1/4D8+	1250	4	1	0.96	4.8	10 x 28	75	10	IP55	60	2.25
LG20/1/8D8+	1250	8	1	1.91	7.3	10 x 28	75	10	IP55	60	2.25
LG20/1/82D8+	1250	8/ 2	1	1.91/ 0.48	8.5/ 6.6	10 x 28	75	10	IP55	62	2.25
LG20/2/4D8+	2000	4	2	1.91	7.3	10 x 28	75	10	IP55	60	4.5
LG20/2/41D8+	2000	4/ 1	2	1.91/ 0.48	8.5/ 6.6	10 x 28	75	10	IP55	62	4.5

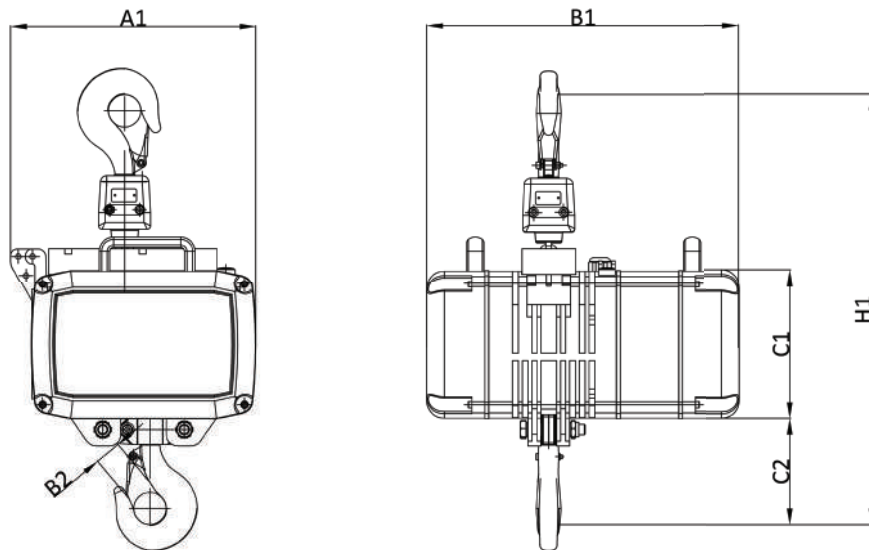

## DIMENSIONS

TYPE	NUMBER OF FALLS	A1	B1	B2	C1	C2	H1
LG10 / D8	1	323	465	32	214	121	583
LG16 / D8	1	379	472	37	230	165	667
LG20 / D8	1	379	472	37	230	165	667

Dimensions of 2 fall hoists on demand  
Drawings available on request

### COMPANY CONTACT DETAILS

**LTM - Lift Turn Move Ltd**  
Unit 2 Stadium Court  
Wirral International Business Park  
Plantation Road, Bromborough  
Wirral, UK CH62 3QG

### SALES AND GENERAL CONTACTS

Tel: +44 (0)151 649 0467  
Fax: +44 (0)151 649 0099  
Email: [sales@LiftTurnMove.co.uk](mailto:sales@LiftTurnMove.co.uk)  
Email: [accounts@LiftTurnMove.co.uk](mailto:accounts@LiftTurnMove.co.uk)  
Website: [www.liftturnmove.co.uk](http://www.liftturnmove.co.uk)

### OPENING HOURS

Mon-Thur: 8:30 - 5:00  
Friday: 8:30 - 2:30

The office is often open outside these times.

### DELIVERIES

We use various methods of delivery and can deliver more or less whenever you need.

To stay up to date with the latest events at LTM please follow us on Facebook, Twitter and LinkedIn



[liftturnmove](https://www.facebook.com/liftturnmove)



[@LiftTurnMove](https://twitter.com/LiftTurnMove)



[@Lift Turn Move Ltd](https://www.linkedin.com/company/liftturnmove)