

LG D8 ENTERTAINMENT CHAIN HOISTS

FOR GENERAL RIGGING PURPOSES TO D8 GUIDELINES

– MAX LIFTING CAPACITY/SWL 1600KG – 5000KG



THE REGULATIONS

Standard hoists that meet current accepted standards and codes of practice for rigging hoists to D8 DGUV54.

GENERAL FEATURES

- » Modern, quiet, reliable and proven design, manufacture and assembly mean long life and competitive pricing
- » Max Lifting Capacity/SWL from 1600kg to 5000kg
- » Direct control or low voltage control
- » Contactor control - (no electronics)
- » Clutch overload device mounted outside the drive train; In the event of clutch problems, the load is not compromised
- » Can be used upright- motor up or climbing - motor down applications
- » Aluminium body - black electrophoretic coated with galvanised plated or black chain
- » Eye body suspension, hook suspension and locking hooks on request
- » Available for 400V, 3Ph power, others on Request
- » Upper and lower geared limit switches

OPTIONS

- » Extra features allow the hoist to conform to higher safety standards when ordered or later modified
- » These options include second brake, standard and ultimate limit switches, load sensing suspensions and encoders for positional feedback
- » Locking hooks
- » Special paint finishes
- » Flight cases



**FOR WHEN YOU NEED TO
LIFT, LOWER, POSITION
OR SUSPEND A LOAD
IN ENTERTAINMENT
RIGGING APPLICATIONS**

LG D8 ENTERTAINMENT CHAIN HOISTS

FOR GENERAL RIGGING PURPOSES TO D8 GUIDELINES

– MAX LIFTING CAPACITY/SWL 1600KG – 5000KG



SPECIFICATIONS

| HOIST TYPE | MAX LIFTING CAPACITY/ SWL | NOMINAL LIFTING SPEED | NO. OF CHAIN FALLS | MOTOR POWER | POWER CONSUMPTION LOADED | CHAIN DIMENSIONS | SOUND PRESSURE LEVEL IN HALL AT 1M DISTANCE | CHAIN SAFETY FACTOR | PROTECTION CLASS | WEIGHT HOIST ONLY | WEIGHT PER METRE LIFT |
|-------------|---------------------------|-----------------------|--------------------|-------------|--------------------------|------------------|---|---------------------|------------------|-------------------|-----------------------|
| | (kg) | (m/min) | | (kW) | (A) | (mm) | dB | | | (kg) | (kg) |
| LG16/1NL.D8 | 1600 | 4 | 1 | 0.76 | 4.5 | 9 x 27 | 75 | 6.4 | IP55 | 60 | 1.75 |
| LG16/1N.D8 | 1600 | 8 | 1 | 1.53 | 6.8 | 9 x 27 | 75 | 6.4 | IP55 | 60 | 1.75 |
| LG16/2N.D8 | 3200 | 4 | 2 | 1.53 | 6.8 | 9 x 27 | 75 | 6.4 | IP55 | 62 | 3.5 |
| LG20/1NL.D8 | 2000 | 4 | 1 | 0.96 | 4.8 | 10 x 28 | 75 | 6.4 | IP55 | 60 | 2.25 |
| LG20/1N.D8 | 2000 | 8 | 1 | 1.91 | 7.3 | 10 x 28 | 75 | 6.4 | IP55 | 60 | 2.25 |
| LG20/2N.D8 | 4000 | 4 | 2 | 1.91 | 7.3 | 10 x 28 | 75 | 6.4 | IP55 | 64 | 4.5 |
| LG250/1N.D8 | 2500 | 3.2 | 1 | 1.53 | 6.8 | 10 x 28 | 75 | 6.4 | IP55 | 60 | 2.25 |
| LG250/1N.D8 | 2500 | 6.4 | 1 | 3.06 | 7.3 | 10 x 28 | 75 | 6.4 | IP55 | 60 | 2.25 |
| LG250/2N.D8 | 5000 | 3.2 | 2 | 3.06 | 6.8 | 10 x 28 | 75 | 6.4 | IP55 | 64 | 4.5 |

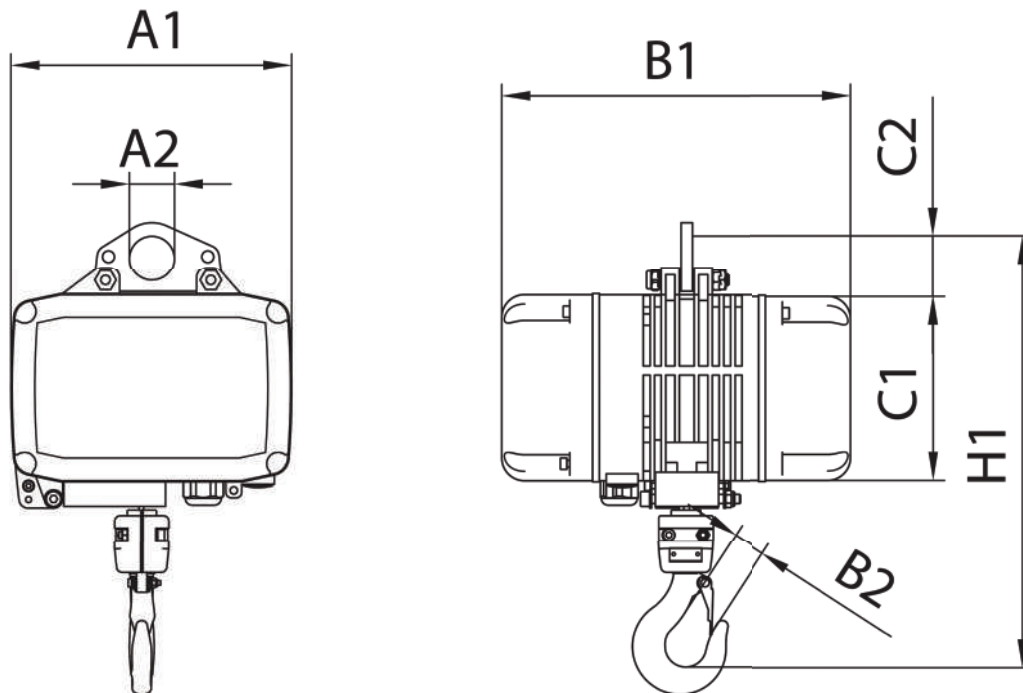

DIMENSIONS

| TYPE | NUMBER OF FALLS | A1 | B1 | B2 | C1 | C2 |
|------------|-----------------|-----|-----|----|-----|-----|
| LG16 / D8 | 1 | 347 | 389 | 37 | 230 | 164 |
| LG20 / D8 | 1 | 347 | 389 | 37 | 230 | 164 |
| LG250 / D8 | 1 | 347 | 389 | 37 | 230 | 164 |

Dimensions of 2 fall hoists on demand
Drawings available on request

COMPANY CONTACT DETAILS

LTM - Lift Turn Move Ltd
Unit 2 Stadium Court
Wirral International Business Park
Plantation Road, Bromborough
Wirral, UK CH62 3QG

SALES AND GENERAL CONTACTS

Tel: +44 (0)151 649 0467
Fax: +44 (0)151 649 0099
Email: sales@LiftTurnMove.co.uk
Email: accounts@LiftTurnMove.co.uk
Website: www.liftturnmove.co.uk

OPENING HOURS

Mon-Thur: 8:30 - 5:00
Friday: 8:30 - 2:30

The office is often open outside these times.

DELIVERIES

We use various methods of delivery and can deliver more or less whenever you need.

To stay up to date with the latest events at LTM please follow us on Facebook, Twitter and LinkedIn



liftturnmove



@LiftTurnMove



@Lift Turn Move Ltd