

WIRELESS VALVE OUTPUT MODULE

INSTALLATION GUIDE

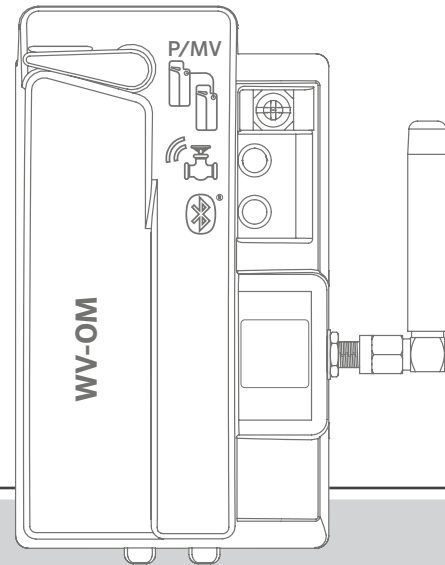

WVOM

Wireless Valve Output Module for Hunter ICC2
and HCC Controllers

Hunter[®]

Table of Contents

- 2 Components
- 3 Installation
- 4 Station Programming
- 5 Basic Troubleshooting
- 6 Passcode Creation
- 6 Database Recovery
- 6 Factory Reset
- 6 Firmware Updates
- 7 Compliance

Get the WVL App to get started!



You will need:

- WVOM Bluetooth® App (free download from Apple or Google Play)
- Two 9 V DC batteries for each Wireless Valve Link to be connected
- Irrigation-grade, waterproof connectors for DC solenoid connections
- 1½" (38 mm) hole saw for Wireless Valve Link valve box lid mounting (included)

Note: Do not use the hole saw on the controller enclosure! The hole saw is for installing the individual Wireless Valve Link devices in valve boxes.

The Wireless Valve Output Module (domestic WVOM or international WVOM-E model) is designed for installation in an output module slot within a compatible Hunter ICC2 or HCC Controller.

The Wireless Valve Output Module is designed to operate with Hunter Wireless Valve Link devices only. It is not compatible with any other manufacturer's devices.

The Wireless Valve Link requires Hunter DC-Latching Solenoids (P/N 458200), which can be retrofitted to almost any existing Hunter valve.

The Bluetooth word mark and logos are registered trademarks owned by Bluetooth SIG Inc. and any use of such marks by Hunter Industries is under license. Apple, the Apple logo, and iPhone are trademarks of Apple Inc., registered in the U.S. and other countries. Google, the Google logo, Android, and Google Play are trademarks of Google LLC.

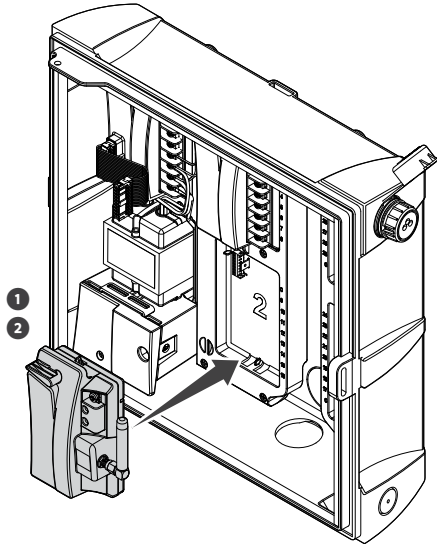

1. Engage the tabs in the output module slot and tip the Wireless Valve Output Module into place until the connector is fully seated.
2. Move the locking lever to the horizontal position to secure the module.
3. Press and release the Reset button on the back of the facepack so the new module is recognized. The controller can now manage 54 stations.
4. When powered on, the module's top LED will display a constant green light to indicate it is active and ready to communicate.



Note

PMV Connection: If wireless control of a PMV output will be used, connect a jumper wire from the PMV terminal on the Wireless Valve Output Module to the PMV output on the controller power module.

P/MV Jumper Wire

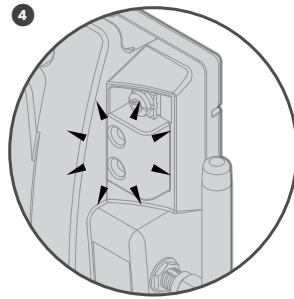
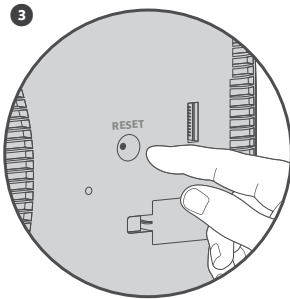
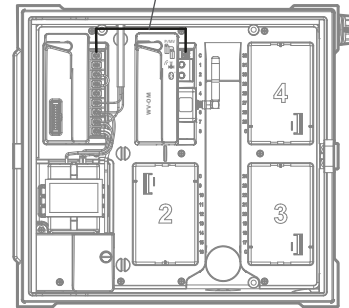

Station Programming

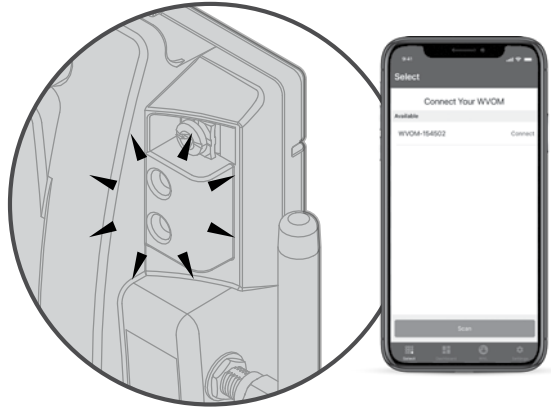

The WVOM has no built-in controls; only LEDs to show status. All programming and diagnostics are done with the free Bluetooth WVL App, available for iOS® or Android® from their respective app stores.

1. Download and install the Hunter WVL App.
2. Open the app on a smartphone. The app will begin immediately scanning for Wireless Valve Output Modules within a range of roughly 50' (15 m) line of sight.
3. A list of available Wireless Valve Output Module devices within Bluetooth range will appear, identified by serial number.
4. Select the Wireless Valve Output Module you're programming and click Connect. The blue LED on the selected Wireless Valve Output Module will light up when it's connected to the phone.
5. Consult the Wireless Valve Link installation guide for programming station addresses into the Wireless Valve Links.

! **Note**
The Hunter WVL APP is designed for WVL programming and diagnostics. There is no station manual operation feature within the app.

Get the WVL App to get started!



For complete operational and troubleshooting information, visit the Hunter Support pages.



hunter.help/WVL

All LoRa® radio communications between the Wireless Valve Output Module and the Wireless Valve Links (or Repeater) are two-way. Whenever the Wireless Valve Output Module sends a message to the Wireless Valve Links or the Repeater, it expects a response.

The two-way communications occur every time the controller attempts to turn on a Wireless Valve Link station.

If the Wireless Valve Output Module does not receive a response after a retry attempt, the module will announce the error both in the controller display and with two internal beeps every 2 minutes.

- The display will show the station number (or P for Pump/Master Valve) along with Err to indicate which station failed to respond.
- The beep will continue until either:
 - the Wireless Valve Output Module is able to communicate successfully with the unresponsive Wireless Valve Link again, or
 - you press the Reset button on the back of the controller facepack.

Use the WVL App to connect to the Wireless Valve Output Module, and go to the Dashboard menu. Click Details. Any Wireless Valve Link with a red status icon has failed to respond.

The most common causes of communication failures are:

Cause	Solution
Low battery	Replace batteries (or inspect solar panel, if using solar power)
Environmental changes (e.g., obstructing vehicle, overgrown foliage)	Locate and remove obstacle, if possible Elevate Wireless Valve Output Module antenna Add Repeater
Radio interference from other devices	Try a different channel (use the app) to eliminate interference
WVL internal failure (e.g., lightning)	Check Wireless Valve Link LEDs in battery compartment for functionality Replace Wireless Valve Link if necessary

The Wireless Valve Output Module range can be extended.

- Elevate the Wireless Valve Output Module antenna with a Hunter Antenna Extension Kit up to 9' (3 m). The Antenna Extension kit is required for use in metal cabinet controllers.
- Add a Hunter Repeater (model RPT in North America, RPT-E in international markets).

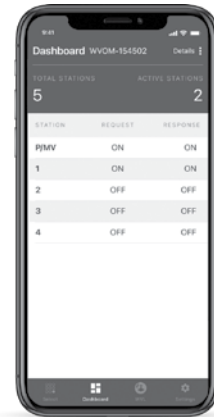

Additional Functions

Passcode Creation

- You can add a passcode (PIN) to the Wireless Valve Output Module to prevent unauthorized access by other Bluetooth smartphone users.
- It's important to remember your passcode or store it in a safe place. If you forget or lose the passcode, other users may no longer be able to access the Wireless Valve Output Module and all the Wireless Valve Link information until it's bypassed. Do not use a PIN that you use for other apps and functions.

Database Recovery

- The recovery feature is used when a Wireless Valve Output Module must be replaced for service reasons or is exchanged with another device.
- The new Wireless Valve Output Module must be relinked to all the Wireless Valve Links in the field to operate.
- Install the new Wireless Valve Output Module, connect it with the app, and choose the Recover Database feature.
- The app will prompt you to enter the serial number of a known device (either a Wireless Valve Link or a Repeater) within the system.
- The Wireless Valve Output Module will use this valid serial number to search for the new device. The Wireless Valve Output Module will then attempt to reach all operational Wireless Valve Links or Repeaters within range. This can take up to 30 minutes.
- When the process is complete, a notification will appear. If all Wireless Valve Links were found, the Wireless Valve Output Module will be ready to irrigate again without further field addressing.

Factory Reset

- The factory reset option will completely erase all Wireless Valve Output Module information, including the Wireless Valve Link database, Channel and Site ID assignments, and Repeater configuration. The whole system will need to be set up again to restore operations.
- From the WVOM Settings menu, select Factory Reset to revert the system to default settings.

Firmware Updates

- Both the Wireless Valve Output Module and the Wireless Valve Links can be updated in the field over the air (OTA), if new firmware becomes available.
- When the process is complete, a notification will appear. If all Wireless Valve Links were found, the Wireless Valve Output Module will be ready to irrigate again without further field addressing.



Note

Firmware updates are large downloads and can take up to 2 hours. Do not start an update if you need to irrigate or perform other diagnostic functions within this time.

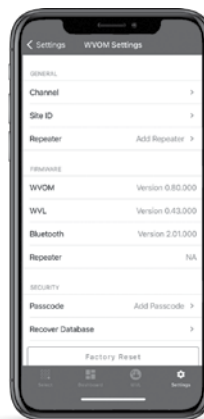

FCC

This equipment has been tested and found to comply with the limits for a Class B digital device pursuant to Part 15 of the FCC Rules. These limits are designed to provide reasonable protection against harmful interference in a residential installation. This equipment generates, uses, and can radiate radio frequency energy and, if not installed and used in accordance with the instructions, may cause harmful interference to radio communications. However, there is no guarantee that interference will not occur in a particular installation. If this equipment does cause harmful interference to radio or television reception, which can be determined by turning the equipment off and on, you are encouraged to try to correct the interference by taking one or more of the following measures:

- Reorient or relocate the receiving antenna.
- Increase the separation between the equipment and receiver.
- Connect the equipment into an outlet on a circuit different from that of which the receiver is connected.
- Consult the dealer or an experienced radio/TV technician for help.

Changes or modifications not expressly approved by Hunter Industries could void the user's authority to operate this device. If necessary, consult a representative of Hunter Industries Inc. or an experienced radio/television technician for additional suggestions.

This device complies with Part 15 of the FCC Rules. Operation is subject to the following two conditions: (1) This device may not cause harmful interference, and (2) this device must accept any interference received, including interference that may cause undesired operation.

This equipment complies with FCC radiation exposure limits set forth for an uncontrolled environment. In order to avoid the possibility of exceeding the FCC radio frequency exposure limits, human proximity to the antenna shall not be less than 20 cm during normal operation.

This transmitter must not be co-located or operating in conjunction with any other antenna or transmitter.

ISED

This device contains licence-exempt transmitter(s)/receiver(s) that comply with Innovation, Science and Economic Development Canada's licence-exempt RSS(s). Operation is subject to the following two conditions:

1. This device may not cause interference.
2. This device must accept any interference, including interference that may cause undesired operation of the device.

Le présent appareil est conforme aux CNR d'Industrie Canada applicables aux appareils radio exempts de licence. L'exploitation est autorisée aux deux conditions suivantes:

1. l'appareil ne doit pas produire de brouillage, et
2. l'utilisateur de l'appareil doit accepter tout brouillage radioélectrique subi, même si le brouillage est susceptible d'en compromettre le fonctionnement.

This equipment complies with the IC RSS-102 radiation limits set forth for an uncontrolled environment. This equipment should be installed and operated with minimum distance of 20 cm from all persons.

Déclaration d'exposition aux radiations:

Cet équipement est conforme aux limites d'exposition aux rayonnements ISED établies pour un environnement non contrôlé. Cet équipement doit être installé et utilisé à plus de 20 cm entre le radiateur et votre corps.

This transmitter must not be co-located or operating in conjunction with any other antenna or transmitter.

Helping our customers succeed is what drives us. While our passion for innovation and engineering is built into everything we do, it is our commitment to exceptional support that we hope will keep you in the Hunter family of customers for years to come.



**Denise Mullikin, President,
Landscape Irrigation and Outdoor Lighting**

HUNTER INDUSTRIES | *Built on Innovation*[®]
1940 Diamond Street, San Marcos, CA 92078 USA
hunterindustries.com

© 2023 Hunter Industries Inc. Hunter, the Hunter logo, and other marks are trademarks of Hunter Industries Inc., registered in the U.S. and certain other countries. ♻️ Please recycle.