



BaseStation 3200

Advanced Irrigation Controller

User Manual

Firmware Version 17.3

July 16, 2019



Customer Service 1-866-294-5847

Baseline Inc.

www.baselinesystems.com

Phone 208-323-1634

FAX 208-323-1834

Toll Free 866-294-5847

©2019 Baseline Inc. All Rights Reserved.

Table of Contents

1 - INTRODUCTION	1
How to Read this Manual	1
Separating Schedules from Flow	1
How to Irrigate Efficiently	2
Watering Strategies	3
WeatherAccess™	4
Soil Moisture Content	5
How to Use Soil Moisture Sensors Successfully	6
Choosing the Primary Zone for a Scheduling Group.....	7
Choosing the Sensor Location	7
Dealing with Slopes and Berms.....	8
Optimal biSensor Placement for Slopes and Berms	8
Burying the biSensor	8
Turf Grass	8
Newly Seeded Turf Grass or New Sod.....	9
Trees and Shrubs	9
Installing biSensors with New Trees	10
Shrubs and Other Ornamental Plants	10
Gardens and Crop Plants	10
Root Depth and Plant Water Efficiency	10
Understanding Soak Cycling	11
Precipitation Rates vs. Infiltration Rates	11
Precipitation Rates for Common Sprinkler Types	11
Estimated Infiltration Rates for Common Soil Types.....	11
Using Soak Cycles with Soil Moisture Sensors.....	12
Distribution Uniformity	12
2 - SYSTEM COMPONENTS	14
Enclosure Options	14
Central Control and Remote Communication Options	15
Remote Communication Options	15
LiveView™	15
BaseManager™	15
Two-Wire Devices	16
Total Supported Devices and Limits	16
Maximum Concurrent Valves.....	17
Maximum Wire Distances for 3200R and 5200R Series biCoders	17
3 - WIRING GUIDELINES	18
Conventional Wiring Modules	18
Connecting Moisture Sensors over Valve Wires.....	19
BL-5200 Series Powered biCoder Wiring Example with One biSensor	19
Expanding with Two-Wire	20
Connecting to BL-5200R Series Wall Mount biCoders.....	21
Connecting Devices to the Screw Terminals	21
Flow Sensor Device	22
Pause Switch Device.....	22
Rain Switch Device	22
Two-Wire Installation	23

Two-Wire Serial Numbers	23
Two-Wire Connections and Layout	23
Wire Connections	23
Wire Lengths.....	24
Wire Layout	24
Wire Burial	25
Removing a Two-Wire Device	25
4 – THE BASESTATION 3200 INTERFACE	26
Controller Front Panel Layout	26
RUN Main Screen.....	27
Zone Status Screen.....	27
All Zones & Programs Status Screen	28
Detailed Status by Program Screen	29
Water Source Status Screen	29
Control Point Status Screen	31
Mainline Status Screen.....	31
Status Colors	32
On-Screen Reports.....	32
Online Help	32
Power Cycling or Restarting the Controller.....	33
Setting the Controller Time and Date	33
Checking the Firmware Version on Your Controller	34
5 – CONFIGURING DEVICES	35
Searching For and Assigning Devices	35
Notes about Assigning biCoders to Zone Numbers	36
Zone Numbers are Pre-Assigned in R-Series	36
Related Topics	37
Configuring Zone Settings	37
Adjusting the Valve Power Level for a biCoder	39
Changing Device Assignments.....	40
Unassigning a Device.....	40
Replacing an Assigned Device with a New Device.....	41
6 – INITIAL PROGRAMMING	42
Setting Up a Time-Based Program	42
Setting Up a Timed Zone	42
To set up a timed zone.....	43
Setting Up a Primary Zone	44
Prerequisites.....	44
To assign a primary zone	44
Linking Zones (Creating a Scheduling Group).....	45
Adjusting the Water Time Tracking Ratio of Linked Zones	46
Using Soak Cycles	46
To set up soak cycles for a zone	47
To disable soak cycles	48
Setting Up Programs.....	48
To set up the start times for a program	49
To set up the start days for a program.....	50
To set up program start days based on a historical calendar	51
Prerequisites.....	51
Programming Instructions	52
To set up the water windows for a program.....	53

To set up a booster pump for a program	54
To set up concurrent zones for a program	54
To enable/disable a program	56
To set the priority for a program	56
To have a program ignore global settings	57
To have a program ignore concurrent zone settings	58
To adjust programs for seasonal variations	58
Associating Zones with a Program	59
Prerequisites	59
Programming Instructions	59
Removing a Zone from a Program	60
Setting Up Soil Moisture Sensor Based Watering	61
Prerequisites	61
Assigning biSensor Soil Moisture Sensors to Primary Zones	61
Unassigning a biSensor Soil Moisture Sensor	62
Configuring the biSensor Settings	63
Understanding Lower & Upper Limit Watering Strategies	64
Lower Limit	64
Lower Limit Programming Requirements	64
Lower Limit Watering Behaviors	65
Upper Limit	65
Upper Limit Programming Requirements	65
Upper Limit Watering Behaviors	65
Complying with Water Restrictions	66
Setting Up Start, Stop, and Pause Conditions	67
To set up a start condition for a program	67
To set up a pause condition for a program or for the entire controller	68
To set up a stop condition for a program or for the entire controller	70
Setting Up Event Dates	71
Setting Up Rain Delay Days	72
7 – FLOW MANAGEMENT & MONITORING	73
Water Source	73
Control Point	74
Mainline	74
Setting Up the Flow Components	75
Setting Up a Water Source	75
Setting Up a Control Point	76
To set up a control point	77
Setting Up a Mainline	78
Setting Up the Hydraulic Layout	78
Connecting a Water Source to a Control Point	79
Connecting a Control Point to a Mainline	79
Assigning Zones to Mainlines	80
Assigning Devices to a Control Point	80
Setting Up Conditions for Water Management	81
Setting Up an Empty Condition for a Water Source	81
Setting Up Control Point Conditions	82
Setting Up Mainline Conditions	82
Delaying a Zone Start Based on Time	82
Delaying a Zone Start Based on Pressure	83
Setting Up Advanced Flow Variance	84

Setting Up Advanced Dynamic Flow Allocation	85
Learning Flow	85
Learning Flow by Zone	85
Learning Flow by Program.....	86
8 – MANUAL OPERATIONS	87
Forcing a Program to Start	87
Stopping an Active Program.....	88
Manually Starting/Stopping the Zones of a Program	88
Manually Running One or All Zones for a Fixed Time	89
Manually Running Zones for a Fixed Time	90
Manually Running Programs for a Fixed Time.....	90
Manually Running a Pump or MV for a Fixed Time	91
Setting the System to OFF.....	92
9 – SYSTEM MANAGEMENT	93
Selecting the Language for Online Help	93
Setting Up Security for the Controller.....	93
Changing the Two-Wire Always On Setting.....	94
Changing the Serial Number of Your Controller	95
Backing Up Your Controller to a USB Drive	95
Backing Up Your Controller to BaseManager	96
Restoring Your Controller from a USB Drive	97
Restoring Your Controller from BaseManager	97
Exporting Controller Data	98
Erasing All Programming from the Controller	99
Erasing All Files from the Controller	99
Updating the Controller Firmware	100
Copying the Firmware Update from the Baseline Website onto a USB Drive	100
Updating the Firmware on the Controller	101
Connecting to BaseManager – Overview	101
Enabling the BaseManager Connection on the Controller	102
Checking the Status of the BaseManager Connection	102
Activating Your BaseManager Subscription	103
Setting Up the Default Network Connection.....	103
Setting Up a Static IP Address	103
Understanding the Ethernet Settings	104
Enabling a Cell Modem Connection	105
Connecting to a FlowStation or SubStation	105
Connecting to a Munro Pump Station	106
10 – REPORTS, MESSAGES, & LOGS.....	107
Zone Status	107
Detailed Status by Program	108
Status Colors	109
Test All Report.....	109
Moisture Sensor Data	109
Program Run Time Report.....	110
Water Used Report.....	110
Pressure Report.....	111
Pump Station Status	111
Operator Messages.....	111
To display the messages.....	112
Pause and Shutdown Messages	112

- 11 – TROUBLESHOOTING.....115**
- Testing a Specific Two-Wire Device115**
- Possible Statuses for Valve biCoders.....115
- Possible Statuses for Soil Moisture Sensors (biSensors)116
- Checking and Repairing Two-Wire Device Assignments and Addresses117**
- Testing All Devices118**
- Performing a Two-wire Blink Test118**
- Troubleshooting the Two-Wire: High Current or Shorted.....119**
- Diagnosing a Circuit Board Issue120
- Troubleshooting with a Milliamp Clamp Meter120
- Troubleshooting Manually121
- Troubleshooting: Lost Devices | No Response121**
- 12 – APPENDIX.....122**
- Warranty122**
- Tips for Setting Up Common Configurations123**
- Lower Threshold Moisture Sensor Based Watering123
- Upper Threshold Moisture Sensor Based Watering123
- BL-3200 Hydrozone Worksheet125**
- Existing Irrigation Controller Information125
- Additional Information for Existing Programs126
- Programming Information for the BaseStation 3200 Controller126
- Additional Information for New Programs128
- Glossary of Terms129**

1 – Introduction

Congratulations on choosing the most capable commercial grade smart irrigation controller in the world! You will find that the BaseStation 3200 is capable of dramatically reducing your water use while improving the health and quality of your landscape. Fully central control compatible, the BaseStation 3200 controller will typically pay for itself in one to 2 seasons based on water waste reduction alone.

The BaseStation 3200 is specifically designed to help you irrigate more efficiently than any other commercial irrigation controller. The 3200 supports multiple smart watering strategies, including smart watering with soil moisture sensors and WeatherAccess™, which is Baseline's weather-based watering mode.

At Baseline, our mission is to change the way people water plants by providing the smartest, easiest and most capable irrigation control products ever made. If you have feedback on how we can make our products better, please do not hesitate to contact us.

IMPORTANT NOTE! Install all electrical components including the BaseStation controller in compliance with local electrical and building codes.

How to Read this Manual

For first time users, sections 1 through 6 provide an overview of how to get your new BaseStation 3200 controller up and running quickly, while sections 7 through 12 provide information on advanced functions and troubleshooting.

For additional information, you can also visit the Baseline website at www.baselinesystems.com

To get the most out of your BaseStation 3200, we recommend that you review the information in this Introduction before you install and configure your system.

Separating Schedules from Flow

A powerful feature of the BaseStation 3200 system design is the separation of scheduling from flow. Rather than having mainlines associated with programs, the zones that water on a specific mainline are assigned to that mainline. Zones can also be assigned to a program without having to be assigned to a mainline. This means that a zone can run without affecting the hydraulic needs of the system.

The separation enables the following functionality:

- A program is used for only scheduling.
- A zone can be assigned to both a program and a mainline, or just to a program.
 - If a zone is assigned to a program and a mainline, water from that mainline is used when the program runs.

- If a zone is not assigned to a mainline, water is not used. The device associated with the zone runs based on the program schedule. This functionality enables you to add items like lights or pond fill switches to the program and run them at the same time as the irrigation.

How to Irrigate Efficiently

This section covers some key concepts that are essential to better and more efficient irrigation. When you irrigate properly, you will reduce or eliminate water waste and improve the health of your plants.

All other considerations being equal, you will see better watering results with soil moisture sensors than with any other currently available technology. When you set up your BaseStation 3200 to water based on soil moisture sensor data, your system becomes a “closed loop” – in other words, the soil moisture sensor directly measures the moisture in the root zone, and the controller adjusts watering to maintain the desired moisture levels.

- **Water deeply and infrequently.** Studies show that watering deeply and infrequently promotes deeper root growth and more drought tolerant plants.

Watering deeply means that the soil should be wetted down to a depth of 6 inches or deeper for grasses and 12 inches or deeper for trees and shrubs.

Watering infrequently means that the next irrigation event (or start time) should be delayed as long as possible without stressing the plants.

- **Deeper roots = more efficient plants.** Plants with deeper roots are able to draw more nutrients from a larger area of soil, making fertilizers and soil treatments more effective.
- **Avoid runoff.** Matching the application rate of irrigation to the infiltration rate of the soil is critical to avoid runoff.
- **Only apply the amount of water needed.** Irrigation water is a supplement to natural rainfall – you only need to apply the amount of water needed to return the soil to optimum moisture.

If you apply more irrigation water than necessary, the excess water will be wasted – water will pool up on the surface and evaporate before it can soak in, it will run off, or it will gravitationally sink through the soil below the root zone of the plants.

Unlike other irrigation controllers, the 3200 is specifically designed to make efficient irrigation easy. Before you start setting up and programming your BaseStation 3200, it is helpful to understand the following concepts:

- Watering Strategies
- WeatherAccess™
- Soil Moisture Content
- How to Use Soil Moisture Sensors, including:
 - Hydrozones
 - Scheduling groups

- Primary zones and linked zones
- Root Depth and Plant Water Efficiency
- Soak Cycling
- Distribution Uniformity

The remainder of this section covers these key concepts in more detail.

Watering Strategies

Each property is unique and has unique watering requirements. In order to support a broad range of climate zones, plant types, landscape designs, and landscape usage requirements, the BaseStation 3200 provides a variety of watering strategies.

One of the most common irrigation programming mistakes is to apply too little water during the hottest days of the season. Baseline recommends that, regardless of watering strategy, you program each zone to water long enough to put down at least ½ inch of water each time the controller is allowed to water.

The basic watering strategies supported by the 3200 are described below.

Timed	Like all irrigation controllers, you can program the 3200 to run zones on specific times and dates. Timed irrigation is the default setting for any zone that has not been associated with a moisture sensor. Refer to Setting Up a Timed Zone on page 42.
Historical Calendar	The BaseStation 3200 allows you to set the days between irrigation according to a Historical ET calendar. This watering strategy, unlike typical seasonal adjustments, will promote deeper root growth and healthier plants throughout the season. However, Historical ET based watering will not protect your landscape from unusual weather patterns in any given season. Read the topic on setting up program start days based on a historical calendar on page 51.
Lower Limit	Also called Lower Threshold. In this soil moisture sensor-based, smart watering strategy, irrigation is suspended or skipped until the soil dries to the lower limit, which may be set manually, or set using the automatic calibration process. This watering strategy naturally waters deeply and infrequently and promotes deeper root growth in plants. The controller will water for a specified runtime each time it is allowed to water. When you are using this watering strategy, remember to ensure that ½ inch or more of water is applied frequently enough to water sufficiently during the hottest period of the season. Refer to Understanding Lower & Upper Limit Watering Strategies on page 64.
Upper Limit	Also called Upper Threshold. In this soil moisture sensor-based, smart watering strategy, irrigation events are scheduled for specific times and dates, but the total runtime is adjusted by the controller to bring soil moisture up and very slightly over field capacity. This watering strategy is particularly useful for landscapes that need to be at a desired moisture level

on a regular schedule, such as sports fields or heavy use parks. On these types of properties, damage to turf takes place when the soil is either too wet or too dry. Refer to Understanding Lower & Upper Limit Watering Strategies on page 64.

For suggestions on programming your controller for these moisture sensor-based watering strategies, refer to Tips for Setting Up Common Configurations on page 123.

Weather-based Watering When operated in WeatherAccess™ mode with an active BaseManager™ Plus subscription, the BaseStation 3200 irrigation controller meets the EPA WaterSense program's water-efficiency and performance criteria.

You need to have your BaseStation 3200 controller installed and connected to your communication module, and your BaseManager Plus subscription activated before you can configure the WeatherAccess settings.

Zones can be linked together and watered as a group, regardless of the watering strategy selected. Refer to Linking Zones (Creating a Scheduling Group) on page 45 for more information.

Also note that, even with soil moisture sensor-based watering strategies, it is important to program the controller so it will put down as much water as required to maintain plant health during the heat of the summer. The 3200 has built-in limits that control how much it is allowed to modify runtimes or watering days before it assumes that there is an equipment malfunction of some kind.

WeatherAccess™

In addition to time-based watering and soil moisture sensor-based watering, the BaseStation 3200 can also be operated in WeatherAccess™, a weather-based watering mode. WeatherAccess applies real-time weather data from a weather station in your area (available in Weather Underground's weather station network), and configurable zone properties to a standardized evapotranspiration (ET) equation. This calculation estimates the loss of moisture from the root zone, and then the irrigation controller uses the calculated value to adjust the runtime in order to apply just enough water to replace that lost moisture.

When operated in WeatherAccess mode, the BaseStation 3200 irrigation controller meets the EPA WaterSense program's water-efficiency and performance criteria.

In WeatherAccess mode, the BaseStation 3200 attempts to calculate the loss of moisture from the root zone and adjust the watering schedule accordingly. The controller's ability to accurately adjust runtimes depends on the quality of the weather data and how accurately the following properties are configured for each hydrozone in your landscape:

- A specific plant type's water needs (known as the "crop coefficient")
- Root zone depth
- The plant's microclimate (ranging from full sun to total shade)
- The application rate of the irrigation method used (spray, rotor, drip, or bubbler)
- Type of soil at the site (clay, sand, or loam)
- Slope of landscape (ranging from slight to extreme)

Having a good working knowledge of horticulture, water management, and an understanding of the science behind weather-based watering will help you be successful with WeatherAccess.

IMPORTANT NOTE! In order to connect to a weather station and access the configuration fields for WeatherAccess, the BaseStation 3200 irrigation controller must be connected to Baseline's BaseManager central control platform, and you must have a BaseManager Plus subscription set up.

For configuration and operating instructions, refer to the WeatherAccess™ User Manual. This manual is available from the Baseline website (www.baselinesystems.com).

Soil Moisture Content

Soil scientists and agronomists have been studying the plant-water-soil system for over 100 years. Early work in irrigation efficiency focused on the estimation of soil moisture based on weather information, plant water requirements, and soil information such as soil texture and slope. With the availability of inexpensive and highly accurate soil moisture sensors, we are able to take soil moisture based irrigation to a whole new level of efficiency and effectiveness.

With soil moisture sensors, your controller can operate like a thermostat for your landscape – applying water when it is needed, and where it is needed.

To understand soil moisture based smart irrigation, you also need to understand the following industry standard terms for soil moisture content.

Wetter ↑ ↓ Drier	Saturation	The soil pores are filled with water and nearly all of the air in the soil has been displaced by water. Gravity exerts force on the water contained in saturated soils, moving it deeper into the ground (if possible). When this “gravitational water” moves down through the soil, it becomes unavailable to plants.
	Field Capacity	The level of soil moisture left in the soil after drainage of the gravitational water. If you irrigate to a level above field capacity, it will result in runoff or drainage as gravitational water.
	Maximum Allowed Depletion (MAD)	When the soil moisture content reaches this level, irrigation needs to start. In most cases, the maximum allowed depletion level is well before the plants begin to show visible signs of stress. Irrigators typically start watering at or before MAD is reached because they do not want their landscapes to show signs of stress.
	Permanent Wilt Point	The minimal point of soil moisture where the plants wilt and begin to die off.
	Oven Dry	When soil is dried in an oven, nearly all water is removed. This moisture content is used to provide a reference for measuring saturation, field capacity, and MAD.

One key point is that water applied above field capacity is generally wasted – it gravitationally moves down through the soil and becomes unavailable to plants. Excess water will also leech nutrients from the soil into deeper soil layers, reducing the efficiency of fertilizers and soil treatments.

To understand field capacity, it is often useful to think of a sponge. If you dunk a sponge in a bucket of water and pull it out, water will gravimetrically drain from the sponge for a period of time. When the dripping stops, the sponge will still be very wet. This moisture level is roughly equivalent to field capacity in soils – water is no longer draining into lower soil layers and is held in the root zone of the plants.

When your irrigation system maintains soil moisture content between field capacity and maximum allowed depletion, you will find that your plants are healthier and your water use actually decreases. Studies also show that appropriately varying the time between irrigation events in order to allow the soil to dry to the chosen depletion point promotes deeper root growth and subsequently more efficiency and drought tolerance from the plants.

How to Use Soil Moisture Sensors Successfully

The first key for success with soil moisture sensors is to consider the hydrozones that exist in your landscaping. A hydrozone is a grouping of plants that have similar water usage and delivery characteristics and can be watered the same. For example, each of the following landscaping areas is a separate hydrozone:

- Grass in full sun with rotors
- Grass in full sun with sprays
- Drip zones in full sun
- Grass in shade with rotors
- Grass in shade with sprays
- Drip zones in shade

After you have identified the hydrozones in your landscaping, determine which irrigation zones are used to water those hydrozones, and then put the irrigation zones into scheduling groups based on their common characteristics. Within the scheduling group, designate the zone where the sensor is located to be the “primary” zone, and then you set up the watering strategy for the scheduling group based on the readings from that sensor. You can link the other zones in the scheduling group to the primary zone so they will be watered more or less relative to it. These zones are called “linked” zones. For more information, refer to Linking Zones (Creating a Scheduling Group) on page 45.

A scheduling group can include any zones that:

- Require irrigation on the same frequency (for example, on the same days)
- Have similar plant types (such as turf, shrubs, or flowers)
- Do not have excessive differences in sun or wind exposure
- Are irrigated with similar water application technologies (assuming zones meet the criteria above)

You can group spray, rotor, and multi-stream zones, as long as the difference in application rates is less than 10x. You can also put drip zones into one group, and subsurface drip zones into another group.

Consider the following example of a sports park that has 4 baseball fields and 4 soccer fields in addition to some perimeter and parking lot shrub areas.

The irrigation manager for the park wants to water the infield areas of the baseball fields differently from the outfields. The manager puts the zones that water the infields of all 4 baseball diamonds into one scheduling group that is controlled by a single soil moisture sensor in one of the infields.

Likewise, the manager puts all zones covering the outfields into a second scheduling group controlled by a single moisture sensor in one of the outfields.

Because all the soccer fields have similar plant types and sun exposures, the irrigation manager can group all zones for all the soccer fields together and control them with a single soil moisture sensor located in one of the fields.

Lastly, the irrigation manager breaks the parking lot and perimeter shrub beds into 2 scheduling groups representing sunny and shady exposures.

In this way, the irrigation manager is able to configure 42 individual zones into 5 scheduling groups that are controlled by 5 soil moisture sensors.

In the example above, the irrigation manager would configure the 5 scheduling groups for the Upper Limit or Lower Limit watering strategy based on readings from the associated soil moisture sensors. However, each scheduling group can be watered according to any watering strategy appropriate for that section of the landscape.

Choosing the Primary Zone for a Scheduling Group

Because the zones in a scheduling group are naturally similar, any zone in a group can make a good primary zone (the zone where the sensor is located). For large scheduling groups, or scheduling groups with a higher level of variation in sun or wind exposure, choose a primary zone that:

- Requires irrigation the most frequently
- Has an average or greater sun and wind exposure for the scheduling group

Choosing the Sensor Location

You will achieve the best results by locating the biSensor in an area that is average for the zone and ideally for the entire scheduling group. Avoid the following areas:

- Drainage areas where irrigation or rainwater pools or is channeled
- Areas immediately around hardscapes or that receive runoff water from hardscapes or buildings

As long as the location of the sensor is average for the zone, you should achieve excellent water efficiency.

Dealing with Slopes and Berms

Steep slopes and berms are possibly the most difficult landscape areas to irrigate efficiently. The main issue is runoff, but often subsurface drainage issues result in low areas that get soaking wet and high areas that are bone dry. When a berm is constructed, the central mass is typically compacted, which can also cause water movement and drainage issues.

Soil moisture sensors are an excellent tool to optimize watering for slopes and berms because the sensor can detect how much irrigation water is actually infiltrating the upper levels of the slope or berm.

Bury the sensor at the top 1/3 of the slope and not at the crown of the slope. Position the sensor in the top 1/3 of the root zone (2-3" for turf grass) and not sideways to the slope.

Take care when you set the soak and cycle times for slopes and berms – for some slopes, you might need to break the total runtime into 5 or more cycles.

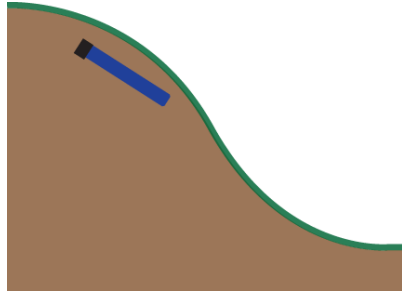

Optimal biSensor Placement for Slopes and Berms

If the slope or berm is irrigated as a part of a larger zone that is mostly level, Baseline recommends that you place the sensor in the larger level area. However, for most efficient results, set up separate zones to water the top, middle, and bottom of slopes and berms.

Burying the biSensor

Install the biSensor according to the installation instructions that are included with it. When installing a biSensor in an established landscape, avoid disturbing the surrounding soil in order to reduce the chance that adjustments will be needed later.

In general, you should install the biSensors in the top 1/3 of the root zone for the plant that is being irrigated. In the case of turf grass, the top of the sensor blade should be 2 inches to 3 inches from the bottom of the thatch layer.

Note: Burying the moisture sensor too deep can cause poor results. If the sensor is deeper than the top 1/3 of the root zone, these roots can become too dry and the plants may become stressed.

Turf Grass

As previously stated, you should bury the sensor 2 inches to 3 inches below the thatch layer, or in the top 1/3 of the root zone of the grass.

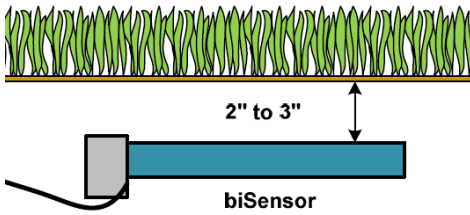

Newly Seeded Turf Grass or New Sod

The default watering strategies for the 3200 are intended to optimize water efficiency for established plants and turf. This style of watering can result in poor performance for newly seeded turf.

If you want to install a sensor in newly seeded turf grass, follow the installation instructions and bury the sensor at the proper depth. Baseline recommends that you water according to an appropriate timed schedule until the grass has rooted sufficiently (typically 60 to 90 days) before enabling a sensor based watering strategy. After the grass has rooted, you can convert the primary zone to a sensor based watering strategy.

Likewise, newly installed sod has very shallow roots. Water the new sod on an appropriate time schedule until it has rooted sufficiently to enable a sensor based watering strategy (typically 30 to 60 days).

Trees and Shrubs

If trees and shrubs are watered separately, a moisture sensor is an excellent tool to maintain their health and beauty. Typically, multiple trees are watered by the same zone. If so, choose an average tree, and install the biSensor in the top 1/3 of the root zone of the tree.

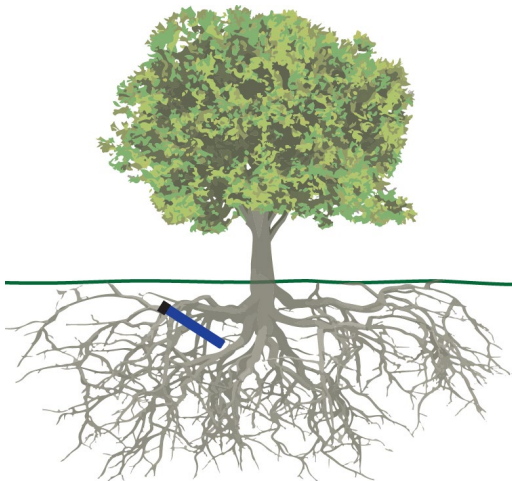

biSensor in the top 1/3 of the root zone of an established tree

Angling the sensor can monitor a deeper soil profile for trees that have deep root structures.

If the tree is watered with drip emitters or bubblers, install the sensor in a location that is not directly under the emitter or bubbler to avoid partial watering of the whole root zone of the tree. If multiple emitters are used for a single tree, a good rule of thumb is to install the sensor roughly half way between 2 emitters and as much inside the root mass of the tree as possible without damaging the roots.

Note: Root depth and water requirements for trees and shrubs vary much more greatly than for turf. Consult an experienced Arborist or Master Gardener for specific guidelines for watering trees.

Most trees are watered along with turf in commercial landscapes. In this case, Baseline recommends that you install biSensors in the turf areas and that you adjust the default runtimes of zones with trees to ensure water application to 12 inches or whatever is required to optimize tree health.

Installing biSensors with New Trees

In the case of new landscape with newly installed trees that are watered separately from turf zones, it is important to make sure that the sensor is located as close to the root ball in the top 1/3 of the root ball as possible. Watering new trees with a sensor based watering strategy is a good way to avoid inadvertently “drowning” new trees and shrubs due to overwatering.

Shrubs and Other Ornamental Plants

Many landscapes feature shrub zones that are separately watered from turf zones. Shrubs generally have very different water needs from turf, so having separate zones is a good thing!

For shrub zones, choose a representative plant, and then install the in or close to the top 1/3 of the root zone for the plant, without damaging the root structure of the plant.

If drip emitters or bubblers are used, install the sensor in a location that is not directly under the emitter or bubbler to avoid partial watering of the whole root zone of the plant.

Gardens and Crop Plants

Sensors are excellent tools for maximizing crop results. They have been used for decades in irrigated agriculture.

Garden and crop plant watering depends greatly on the type of plants being grown, and a discussion of this topic is beyond the scope of this manual.

To plan a watering strategy for larger gardens or crops, Baseline recommends that you contact your local Cooperative Extension Office. You can find a national register of the extension offices at: <https://offices.sc.egov.usda.gov/locator/app>

Root Depth and Plant Water Efficiency

Studies show that most plants, in particular standard turf grasses, do not grow deeper roots unless prompted to do so. While some turf grass varieties rapidly grow deeper root structures when properly watered, even Kentucky bluegrass will grow roots in excess of 12 inches in appropriate soil textures when it is watered optimally.

Watering deeply and infrequently on a consistent basis will promote healthier plants with deeper root structures. As roots grow deeper, the plants are then able to access water in deeper and typically wetter soil layers, making them even more water efficient. Plants with deeper roots are also able to draw nutrients and fertilizers from deeper soil layers, making the plants more nutrition efficient as well.

Understanding Soak Cycling

When you set up your irrigation programs, remember that the rate at which the irrigation application devices apply water might be very different than the rate at which the soil in your landscape can take up that water.

Soak cycling breaks the total runtime into shorter water “cycles” with “soak” periods in between to allow time for water to soak into the soil.

Precipitation Rates vs. Infiltration Rates

The precipitation rate, which is the rate at which sprinkler heads or drip emitters apply water to the soil, is typically measured in inches, like rainfall.

Many soils only allow water infiltration at a rate of .25 inch per hour or less, whereas most head types put down .50 inch per hour or more (much more in the case of some spray heads).

Also remember that head spacing and overlap directly influence the total precipitation rate for any specific zone.

Precipitation Rates for Common Sprinkler Types

Spray Heads	1.00 inch to greater than 5.00 inches per hour
Gear Driven Rotors	0.25 inch to 0.65 inch per hour
Multi-stream Rotors	0.40 inch to 0.60 inch per hour
Drip Emitters	Depends on area covered, rarely exceeds infiltration rate

Estimated Infiltration Rates for Common Soil Types

Course Sand	0.75 inch to 1.00 inch per hour
Fine Sand	0.50 inch to 0.75 inch per hour
Fine Sandy Loam	0.35 inch to 0.50 inch per hour
Silt Loam	0.15 inch to 0.40 inch per hour
Clay Loam	0.10 inch to 0.20 inch per hour

As you can see from the tables above, most sprinkler heads have higher precipitation rates than the infiltration rate of most soils.

When the irrigation schedule puts down more water than the soil can take up, the excess water will typically run off to the lowest point, leaving some areas of the landscape, or even the entire

irrigated landscape, under watered. Standing water also evaporates at a fairly high rate, especially in the heat of the summer months, further reducing irrigation efficiency.

Even on a perfectly designed system, it is important to match the water application rate to the infiltration rate of your soil. You can achieve this balance by breaking a total watering time for any zone into multiple “cycles” (timed water applications) and “soaks” (timed wait periods, which will allow the water applied in the last cycle to infiltrate into the soil before more water is applied).

The BaseStation 3200 has built-in support for soak cycling and has intelligent watering algorithms that apply cycles in the optimal order to maximize water penetration and minimize evaporation loss.

As a rule-of-thumb, Baseline recommends that you break the total water time for any zone into at least 3 cycles, and configure the soak time between cycles to be at least twice the length of the cycle time.

Note: One easy way to determine good cycle times is to turn a zone on and watch for first signs of standing water or runoff. Set the cycle time to be no more than this amount of time.

Properly setting soak and cycle times will dramatically improve water penetration and watering efficiency.

Note: If you have a BaseManager Plus subscription, you can configure settings for your hydrozones that will enable the system to calculate appropriate cycle times and soak times for the zones.

Using Soak Cycles with Soil Moisture Sensors

Soak cycling is required on all soil moisture based zones or scheduling groups in order to ensure that the applied irrigation water is reaching the moisture sensor.

If you set a zone or program to start when the soil moisture sensor reading is less than or greater than the limit, you should set up at least 3 soak cycles with a soak time that is at least twice as long as the cycle time.

Distribution Uniformity

Distribution uniformity (DU) refers to how evenly water is applied over the area in a particular zone or landscape. This is generally driven by the choice of heads (spray, rotor, multi-stream, etc.) and by the irrigation design.

In reality, it is very common that distribution uniformity is fairly low in irrigated landscapes. Poor distribution uniformity is based on many factors beyond the scope of this manual, but it is important to note that system problems such as uneven coverage will limit the effectiveness of smart watering strategies.

Baseline’s experience is that high-uniformity systems can be built from nearly any head type, as long as it is properly designed, installed and maintained.

IMPORTANT NOTE! The BaseStation 3200 controller can compensate for, but cannot solve, distribution uniformity problems.

As you intelligently reduce water applied to any zone, you may notice stressed areas or brown spots in your landscape. When this happens, you should first adjust your heads to make coverage as even as possible. In extreme cases, you may find it advantageous to retrofit older heads with new types of heads such as multi-stream rotors that apply water more evenly. Fixing distribution uniformity issues has better long term results than increasing water times or moisture settings.

Every irrigation controller must be programmed to water to the “driest spot” in each zone. If the difference between water applied at the driest spot is too great (especially if the wettest spot has more than 3 times the water applied in the same period as to the driest spot) then you should take steps to adjust your heads, their spacing, and their coverage to gain better uniformity.

You can quickly and easily measure the distribution uniformity of your landscape by placing catch cups in any particular zone and then running that zone for a specific period of time. Auditing zones in this manner will also give you precise information about how much water is applied per hour in that zone, which makes it easy to set default water times. Baseline highly recommends that you audit zones in order to determine uniformity and actual application rates.

2 – System Components

This section covers the components, devices, and communication options that are available for the BaseStation 3200 irrigation controller. This section also gives the total supported devices and limits.

Enclosure Options

Your BaseStation 3200 will be installed in one of the following enclosures:

- **X-series** – Powder-coated (X) or stainless steel (XS) indoor/outdoor wall mount cabinet
- **P-series** – Stainless steel pedestal enclosure

Note: All enclosure dimensions are in inches.

X/XS-series

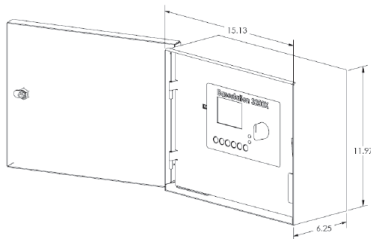

P-series

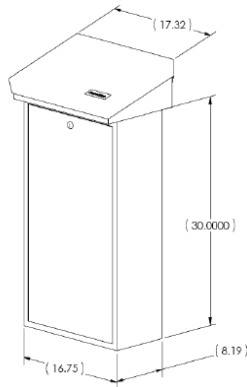

Follow the instructions in the installation guide that came with the enclosure.

Central Control and Remote Communication Options

The BaseStation 3200 is compatible with a number of remote communication options to enable connectivity to Baseline's central control applications including LiveView and BaseManager.

Remote Communication Options

The BaseStation 3200 controller is compatible with the following remote communication options:

- Cellular Modem
- Ethernet
- Wireless Ethernet (Wi-Fi)
- Ethernet Radio
- Long haul Ethernet

Note: To install the remote communication devices, refer to the instructions included with the device.

LiveView™

LiveView makes your controller accessible at anytime from anywhere, with any Internet-accessible device, just as if you were standing in front of it.

To take advantage of LiveView, the controller needs to be connected the Internet with one of the supported communication options. You access the LiveView interface through the BaseManager application in AppManager.

Note: LiveView performance is limited with a cellular modem connection.

BaseManager™

BaseManager is a powerful cloud-based central control and remote access application available through the AppManager framework. BaseManager enables any BaseStation 3200 controller to be managed remotely over the Internet. With BaseManager, you can do everything you normally have to do at the controller, from the convenience of any Internet connected device.

In order for a BaseStation irrigation controller to connect to BaseManager, the controller must have access to the Internet. Every BaseStation 3200 controller has a built-in Ethernet port that is Internet ready. You can also connect the controller to the Internet through with one of the other supported communication options.

Note: Your organization can also run BaseManager on a self-hosted server.

For more information, refer to Connecting to BaseManager – Overview on page 95.

Two-Wire Devices

The BaseStation 3200 can communicate with all of the following Baseline accessories:

- 1, 2, and 4 valve biCoders
- 12, 24, 36, and 48 zone 5200R series powered biCoders
- biSensor soil moisture sensors
- Flow sensor biCoders for connection to third-party flow sensors and master valves
- PFS series smart PVC flow sensors
- BHM series hydrometers – metal-body flow meter and master valve combination
- Pause biCoder – compatible with any standard normally closed pause device such as a rain switch or a wind switch
- Air temperature biCoder
- Pause button (also called a “coach’s button”)
- Pump relay biCoder
- Lightning arrestor/surge suppression devices
- Pressure sensors

Total Supported Devices and Limits

The following table lists the total numbers of devices by type that can be connected to a BaseStation 3200. The BaseStation 3200 can support up to 110 device loads on the two-wire path within the layout and length limits outlined later in this section. The load value/rating for each two-wire device is shown in the table below.

Two-Wire Device Type	Total	Device Loads
Valve biCoders	200	½ per biCoder
5200R series biCoders	20	2 per biCoder
biSensors	25	1
Master Valves/Pump Starts	8	1
Flow Meters	8	3
Event Devices	8	1
Temperature Sensors	8	1
Pressure biCoders	8	3

You can configure 200 zones in the 3200 or 3200R controller. Unused ports or serial numbers on biCoders do not occupy a zone address and do not count towards the 200 zone limit.

Maximum Concurrent Valves

The maximum number of concurrently operating valves is shown in the 2 tables below. The number of concurrent valves varies based on the total load count and wire length to the farthest device:

Maximum Concurrent Valves -#12 Wire							Maximum Concurrent Valves -#14 Wire					
Wire Length (ft)							Wire Length (ft)					
biCoder and Sensor Load Count	1000-3000	4000	5000	6000	7000	8000	biCoder and Sensor Load Count	1000	2000	3000	4000	5000
	100	15	14	13	8	6		4	100	13	11	8
90	15	15	14	9	7	5	90	14	12	9	5	3
80	15	15	15	10	8	6	80	15	12	10	6	4
70	15	15	15	11	9	7	70	15	13	11	7	5
60	15	15	15	12	10	8	60	15	14	12	8	6
50	15	15	15	13	11	9	50	15	15	13	9	7
40	15	15	15	14	12	10	40	15	15	14	10	8
30	15	15	15	15	13	11	30	15	15	15	11	9
20	15	15	15	15	14	12	20	15	15	15	12	10
10	15	15	15	15	15	13	10	15	15	15	13	11

Maximum Wire Distances for 3200R and 5200R Series biCoders

Maximum Wire Distance Between Powered biCoder and Valve (ft)

Common Wire #	Valve Wire # (gauge)						
	18	16	14	12	10	8	6
18	800	1000	1200	1300	1400	1500	1500
16	1000	1300	1600	1900	2100	3200	2400
14	1200	1600	2100	2600	3000	3400	3700
12	1300	1900	2600	3300	4100	4800	5400
10	1400	2100	3000	4100	5400	6600	7600
8	1500	2300	3400	4800	6600	8700	10500
6	1500	2400	3700	5400	7600	10500	13300

Moisture sensors can communicate over valve wire distances equal to ½ the values on this chart to a maximum distance of 1500 ft.

3 – Wiring Guidelines

Review this section to find instructions for wiring your BaseStation 3200 irrigation controller and for connecting the standard and optional devices.

Conventional Wiring Modules

BaseStation 3200R controllers and Baseline 5200R Series Powered biCoders connect directly to conventional 24 VAC irrigation wiring, with one wire for each valve plus a common wire. Additionally, these devices are capable of communicating to soil moisture sensors over specific terminals that are enabled to search for and communicate with Baseline biSensors.

You can equip each 3200R controller with 12, 24, 36, or 48 zones. An X, XS, or P cabinet accommodates two 12 or 24 zone connection modules.

The terminal designations for each 12 or 24 zone connection module are shown in the diagram on the right, and include:

- Rain Sensor Port (Normally Closed)
 - Note:** When you connect a rain click device directly to this port, the device will function globally without any programming. When the contacts on the device open, all watering will be set to Done and no watering will start until the next start time after the contacts have closed.
- Two-wire Port (Red and Black)
- Valve Common (x2)
- Master Valve/Pump Start terminals (2, designated VE1 and VE2) – you can re-address these terminals to control conventional zones if desired
- Sensor-over-valve-wire Ports (x2 for 12 zone, x4 for 24 zone) each with a status LED
- Standard valve wire ports (x10 for 12 zone, x20 for 24 zone)

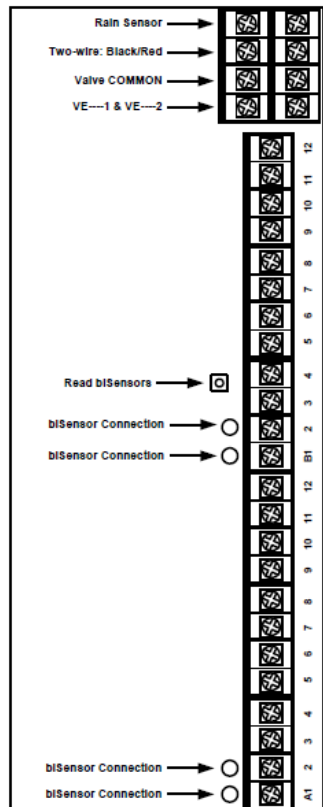

Only 2 zones of any 12 zone block of terminals can be activated concurrently, plus VE1 and VE2, resulting in a total concurrency of 6 zones for a 24 zone unit.

You can connect Baseline biSensors directly to valve wires on the Sensor-over-valve-wire ports (A1, A2 and B1, B2).

BaseStation 3200R systems have built-in biCoders, and each screw terminal has a unique serial number. These serial numbers are listed on the wiring label that is included in the unit as shown in the illustration below.

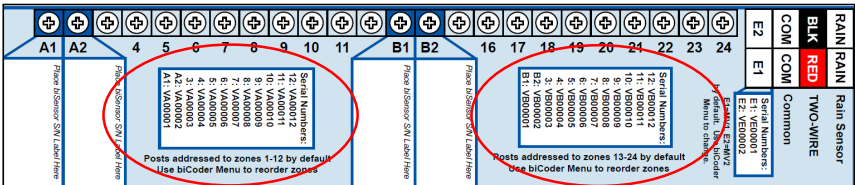

Serial Numbers for zones 1-24 on a BL-5200 Series Powered biCoder™

Powered biCoders are preconfigured at the factory to assign zones 1 to 48 (depending on how many zones the unit is equipped with) to terminals 1 through 48. However, by using the specific serial number, you can reassign any terminal to any zone address. Refer to the topic on changing device assignments on page 40.

Connecting Moisture Sensors over Valve Wires

You can connect Baseline biSensors directly to the valve wires on the Sensor-over-valve-wire Ports (A1, A2, B1, B2) on any 12 or 24 zone connection module.

BL-5200 Series Powered biCoder Wiring Example with One biSensor

1. Power off the two-wire when installing devices. Leave 24 to 36 inches of slack on the two-wire to allow for easy installation and maintenance.
2. Wire the sprinkler valves directly to the zone connectors and common connector.
3. Locate the biSensor near the closest valve location.
4. Connect the red wire from the biSensor to the power wire or pilot wire of the valve and black wire from the biSensor to the common wire of the solenoid using the provided 3M™ DBR/Y-6 Direct Bury Splice Kit connector. It is critical that polarity be maintained.

Note: Use wire nuts to test communication, and then replace those wire nuts with 3M™ DBR/Y-6 Direct Bury Splice Kit connectors before burying.

5. Follow the “Burying the biSensor” instructions, included with the biSensor.
6. Connect the pilot wire from the valve to the A1, A2, B1, or B2 terminals.
7. Press the biSensor update button and verify that the light above the terminal stays on.
8. Assign the biSensor and test its operation. Refer to Searching for and Assigning Devices on page 35 and Testing a Specific Two-Wire Device on page 115.

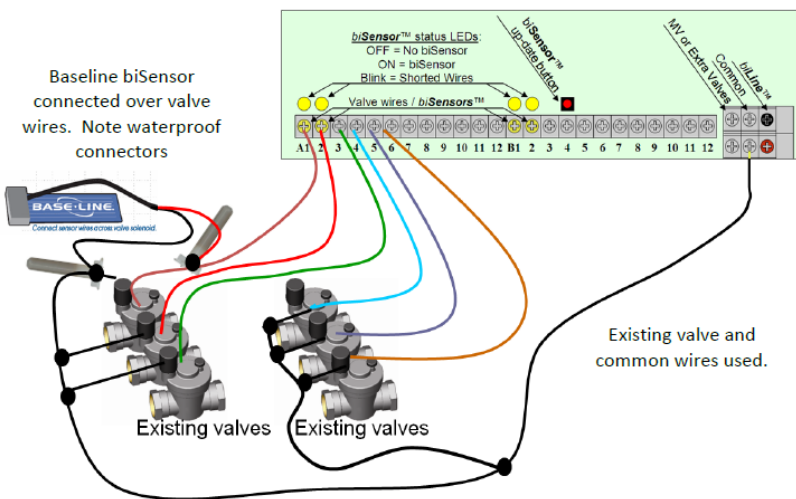

BL-5200 Series Powered biCoder Wiring Example with One biSensor

Expanding with Two-Wire

All BaseStation 3200 controllers are capable of communicating with Baseline biCoders and biSensors connected to a two-wire path. Any supported two-wire devices may be connected.

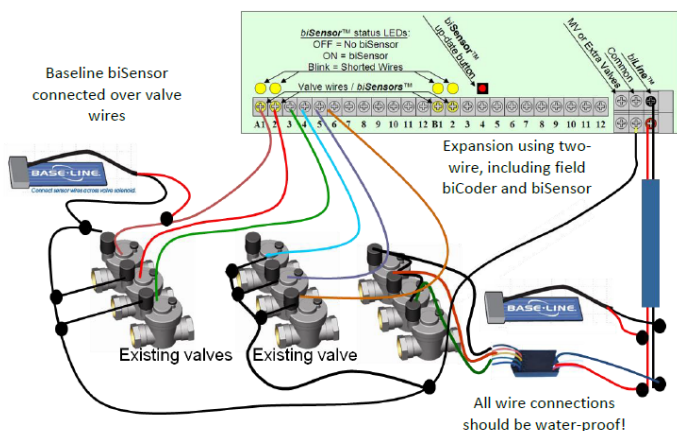

Two-Wire Expansion Example

Connecting to BL-5200R Series Wall Mount biCoders

Baseline 5200R Series Powered biCoders are specifically intended for retrofit applications and make combining several old controllers into a single BaseStation 3200 easy and affordable.

BL-5200X-R48 – 48 Zone Wall Mount biCoder in an X-Series Cabinet

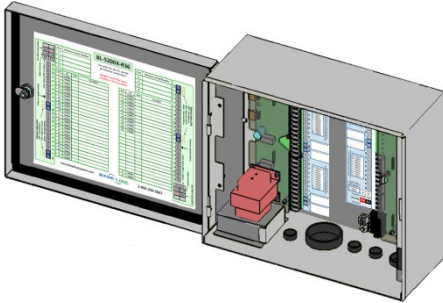

5200R Series Powered biCoders require 110 VAC power (240 VAC for –INT versions) and are installed with the controller in X/XS-series wall mount cabinets, or P-series pedestals.

You can connect up to 20 5200R Series Powered biCoders to a single BaseStation 3200, which enables you to retrofit a large site with multiple controllers into a single BaseStation 3200 controller.

Connecting Devices to the Screw Terminals

The controller board inside the enclosure has 10 screw terminals. Four of these screw terminals are for attaching two-wire, 4 are labeled Flow, Pause, Rain, and Common, and 2 are labeled 24VAC. You can replace the factory jumper wires on these terminals with compatible flow sensor, pause switch, and rain switch devices.

If your controller has a 5200R Series Powered biCoder, you will see 8 screw terminals. Two are labeled rain, 2 are for attaching two-wire, 2 are labeled Com(mon), and 2 are labeled E1 and E2.

A connected device is read each minute, but the device must be read as open 2 times in a row before action is taken. This means that it could take 2 minutes for the controller to respond after a device is read.

Devices connected to the screw terminals have the following behaviors.

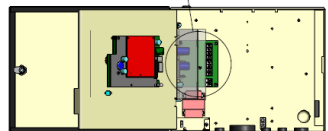
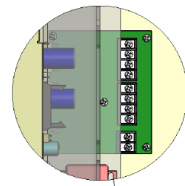

Location of the screw terminals on a controller in an X cabinet

Flow Sensor Device

- A device connected to this terminal influences non-FlowStation programs, control points, and booster pumps.
- When the flow sensor contacts open, all watering is shut down:
 - All programs and zones are set to done.
 - All booster pumps are shut off.
 - All control points are shut down.
 - All learn flow operations are terminated.
- The controller displays a message about the flow shutdown condition. To resume watering, you must clear the message and return the flow sensor contacts to the closed state.

Pause Switch Device

- A pause switch connected to this terminal influences all programs on both the local controller and FlowStation programs.
- When the pause switch contacts open, all water is paused for 4 hours. The timer starts over at 4 hours each minute that the switch contacts are open.
- The controller displays a message about the paused condition. Watering will resume where it left off when the switch contacts are closed, and the 4-hour timeout is complete.

Rain Switch Device

- A rain switch connected to this terminal influences all programs, both local and FlowStation programs.
- When the rain switch contacts open, all watering is stopped, and all programs and zones are set to done. All programs will be immediately stopped if they are started. No programs can run while the rain switch contacts are open.
- The controller displays a message about the rain switch condition. When the rain switch contacts close, the message is removed automatically so that watering can resume (programs that were stopped are still stopped).

Note: When a 5200R-Series Powered biCoder is directly connected to the controller board, a rain switch connected to the screw terminals behaves as described above. However, when a 5200R-Series Powered biCoder is in its own enclosure or is mounted in an enclosure as a supplemental board, the rain switch terminals are disabled.

Two-Wire Installation

All BaseStation 3200 and 3200R controllers are equipped with a full-function two-wire port capable of connecting to valve biCoders, powered retrofit biCoders, biSensors, flow meters, and other devices. Because Baseline's biLine protocol provides full bidirectional communications, you can connect all your irrigation accessories to the same two-wire path – saving time and money compared to conventional wiring.

Two-Wire Serial Numbers

Each Baseline two-wire device has a unique serial number used to identify it. Serial numbers are labeled on all Baseline devices. For devices such as 2 or 4 zone biCoders, each output for the biCoder has a unique serial number, even if it only has one serial number listed on its label.

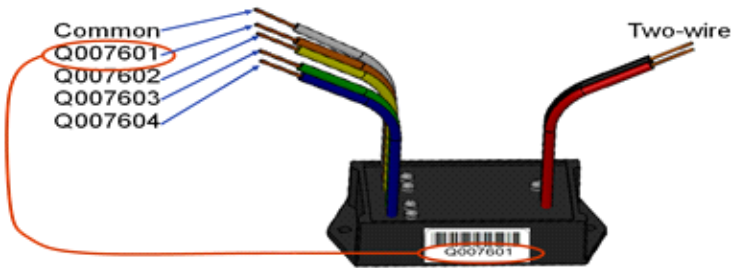

Serial Numbers for a 4-zone biCoder

Two-Wire Connections and Layout

Baseline uses a proprietary digital protocol to communicate over two-wire. For the complete and up-to-date two-wire specification, please refer to the Resource Library on the Baseline website. Failure to use approved wire will invalidate the BaseStation 3200 warranty.

Wire Connections

Install all wire connections in compliance with the connector manufacturer's instructions, and make sure that the connections are fully waterproof.

Note: Use a 3M™ DBR/Y-6 Direct Bury Splice Kit connector.

CAUTION! Do not connect the two-wire and valve common terminals together because this will damage your BaseStation.

Baseline recommends that you allow 24 to 36 inches of strain relief at each wire connection to make valve box installation and troubleshooting easier and to prevent thermal expansion from pulling connections apart on long wire runs.

Wire Lengths

Total wire length supported depends on the gauge of the wire used.

Straight Run

Wire Size (Gauge)	#18	#16	#14	#12
Wire Length (ft.)	1,900	3,100	5,000	8,000
Total Wire From One Controller = 16,000 ft.				

Looped Run

Wire Size (Gauge)	#18	#16	#14	#12
Wire Length (ft.)	3,800	6,200	10,000	16,000

Wire Layout

Straight line, star, looped, and combination configurations are supported.

While the loop topology might provide a more robust configuration, it is harder to trace the wiring errors that might occur. For this reason, Baseline recommends the other topologies over the loop.

The straight line and the star topology are the recommended layouts. To simplify the illustrations, only the last device is shown for most configurations. You can assume that other devices, both sensors and biCoders, are connected along the length of the two-wire path. On a star configuration, the topology has multiple last devices. Each device must separately meet the distance requirement.

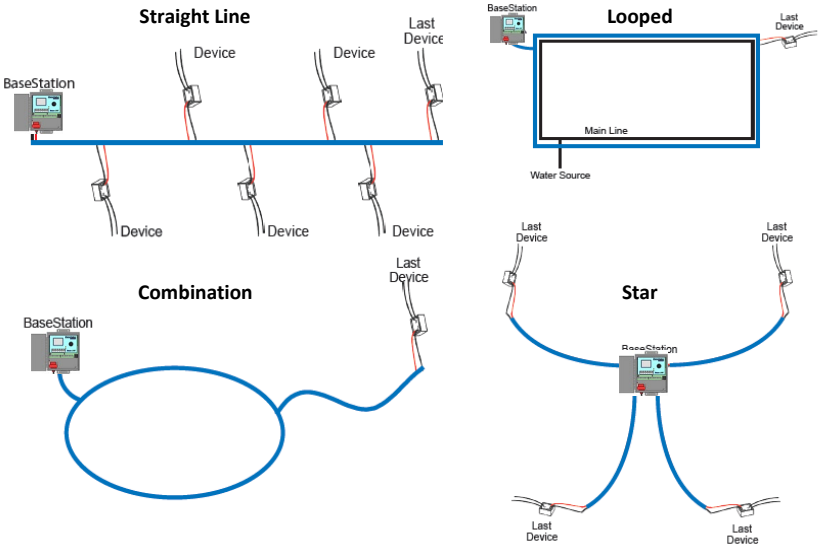

Wire Burial

Bury all wire at an appropriate depth to protect it from mechanical damage due to digging or aeration.

Baseline's two-wire system operates under 30 VAC RMS, which is considered safe for shallow burial as outlined in the National Electric Code. All installations should comply with local electrical codes.

Removing a Two-Wire Device

If you want to remove a two-wire device, first you must physically disconnect it from the two-wire, and then you perform a Search operation from the device specific menu in the controller.

Example: If you need to remove a biSensor, physically disconnect the biSensor from the two-wire. Then go to the controller and turn the dial to Assign. Perform the steps to search for the biSensor (refer to Searching For and Assigning Devices on page 35). When the controller detects that the biSensor is no longer connected, it will remove the device from the configuration.

Note: Refer to the Configuring Devices section on page 35 of this manual for the configuration procedures for the various two-wire devices.

4 – The BaseStation 3200 Interface

Review this section to get familiar with the layout of the BaseStation 3200 interface. This information covers the components of the front panel, the Online Help, the features of the main screen, as well as the status colors and a brief overview of the on-screen reports.

Controller Front Panel Layout

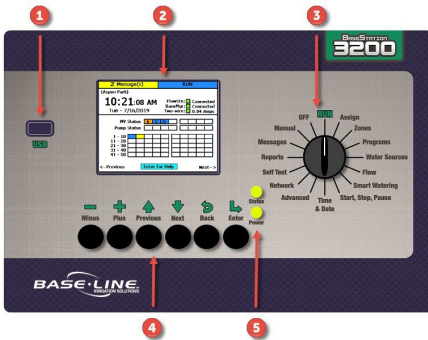

(1) USB Port – The USB port is used for doing Backup and Restore operations using a USB drive (also known as a “thumb drive” or a “flash drive”). The USB port is also used for doing firmware updates and exporting operation log files.

(2) Display – The color display indicates the current state of the controller and is used to display programming. This display uses thin-film transistor (TFT) technology to improve image quality in outdoor conditions including direct sunlight and low light.

(3) Dial – The dial is used to select the operation or programming mode of the controller.

(4) Buttons – The buttons are used to select programming elements, change their values, and initiate operations like testing a zone.

- +** Increases the value of the selected field or moves sequentially through the available options in the selected field
- Decreases the value of the selected field, or moves sequentially through the available options in the selected field
- Next** Moves the highlighted selection to the next field on the display
- Previous** Moves the highlighted selection to the previously selected field on the display
- Back** Moves back to the previous menu and can sometimes be used to stop an operation
- Enter** Applies the current selection and moves to the next item, or begins the operation

(5) Status LEDs – These 2 LEDs indicate the power status of the controller and the internal status of the controller hardware. The upper light is normally ON, but it may blink when internal diagnostics are run.

RUN Main Screen

When the controller dial is in the **RUN** position, the main screen displays the Zone Status. Press the **Next** or **Previous** button to cycle through the other available screens including the All Zones & Programs Status, the Detailed Status By Program, the Water Source Status, Control Point Status, and Mainline Status. You can leave one of these alternate screens visible and it will continue to display when the controller dial is in the **RUN** position until the controller is reset. At that point, the Zone Status screen redisplay.

Zone Status Screen

The Zone Status screen is the default main screen when the controller dial is in the **RUN** position. Zones 1 – 50 are shown and the colors in the grid represent the status of each zone. For an explanation of the colors, refer to the Status Colors topic on page 32.

Press the + button to display the next group of 50 zones. Press the – button to go back through the groups.

MV Status
Pump Status

Green=Idle
Blue=Watering
Orange=Off
Red=Error

C=normally closed
O=normally open

4 Message(s)	RUN
{Aspen Park}	
10:42:34 AM	FlowStn: <input type="checkbox"/> Connected
Tue - 7/16/2019	BaseMgr: <input type="checkbox"/> Connected
	Two-wire: <input type="checkbox"/> 0.84 Amps
MV Status	<input type="checkbox"/> B <input type="checkbox"/> C <input type="checkbox"/> O <input type="checkbox"/>
Pump Status	<input type="checkbox"/> <input type="checkbox"/> <input type="checkbox"/> <input type="checkbox"/>
1 - 10	<input type="checkbox"/> <input type="checkbox"/> <input type="checkbox"/> <input type="checkbox"/> <input type="checkbox"/> <input type="checkbox"/> <input type="checkbox"/> <input type="checkbox"/> <input type="checkbox"/> <input type="checkbox"/>
11 - 20	<input type="checkbox"/> <input type="checkbox"/> <input type="checkbox"/> <input type="checkbox"/> <input type="checkbox"/> <input type="checkbox"/> <input type="checkbox"/> <input type="checkbox"/> <input type="checkbox"/> <input type="checkbox"/>
21 - 30	<input type="checkbox"/> <input type="checkbox"/> <input type="checkbox"/> <input type="checkbox"/> <input type="checkbox"/> <input type="checkbox"/> <input type="checkbox"/> <input type="checkbox"/> <input type="checkbox"/> <input type="checkbox"/>
31 - 40	<input type="checkbox"/> <input type="checkbox"/> <input type="checkbox"/> <input type="checkbox"/> <input type="checkbox"/> <input type="checkbox"/> <input type="checkbox"/> <input type="checkbox"/> <input type="checkbox"/> <input type="checkbox"/>
41 - 50	<input type="checkbox"/> <input type="checkbox"/> <input type="checkbox"/> <input type="checkbox"/> <input type="checkbox"/> <input type="checkbox"/> <input type="checkbox"/> <input type="checkbox"/> <input type="checkbox"/> <input type="checkbox"/>
<--Previous	Enter for Help
	Next-->

Note: Refer to the All Zones & Programs Status Screen illustration on the following page for more details.

All Zones & Programs Status Screen

When the controller dial is in the **RUN** position and the main Zone Status screen is displayed, press the **Next** button to go to the All Zones & Programs Status screen.

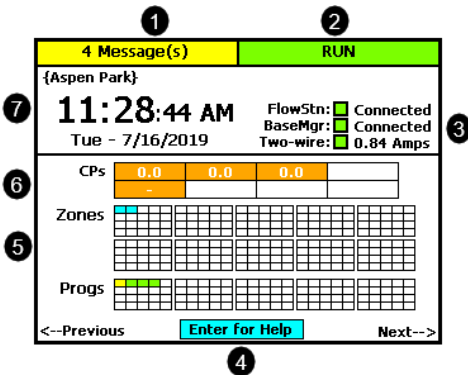

- 1 Messages are indicated here. BUSY displays to indicate that the controller is performing watering calculations and communicating with devices.
- 2 The controller's current state.
- 3 Indicates the status of the BaseManager connection and any performance components. Indicates the status of the two-wire.
- 4 Press the enter button to display the online help.
- 5 Status overview of zones and programs. Press the Previous or Next button to see detailed screens.
- 6 Real-time flow meter value and status for the control points.
- 7 The controller's name, date and time.

If you leave the All Zones & Programs Status screen displayed, it will continue to display when the controller dial is in the **RUN** position until the controller is reset. At that point, the Zone Status screen redisplay.

When the All Zones & Programs Status screen is displayed, press the **Previous** button to return to the Zone Status screen, or press the **Next** button to go to the Detailed Status By Program screen.

Detailed Status by Program Screen

When the controller dial is in the **RUN** position and the main Zone Status screen is displayed, press the **Next** button twice to display the Detailed Status By Program screen.

Press the **+** or **-** button to cycle through the controller's programs.

The colored box on the left indicates the program status. Refer to the Status Colors topic on page 32 for an explanation of the colors.

The following information is available in the fields:

Last Start: The date and time when the program was started for any condition including manual starts. The field also indicates what caused the last start.

Last Pause: The date and time of the most recent pause. The pause information shows until the program is started again. The field also indicates what caused the last pause.

Last Stop: The date and time when the program last completed watering. When a program is watering, this field is blank. The field also indicates what caused the last stop.

Next Start: The estimated next start date and time for the program. In some cases, the start condition for a program makes it difficult to accurately estimate when the next start will occur. Consider the information in this field as helpful, but remember that it might not be perfectly accurate depending on the program settings.

Avg Time: An average of the last 3 runtimes.

Avg Water: An average of the amount of water used during the last 3 runtimes.

If you leave the Detailed Status By Program screen displayed, it will continue to display when the controller dial is in the **RUN** position until the controller is reset. At that point, the Zone Status screen redispays.

When the Detailed Status By Program screen is displayed, press the **Previous** button to return to the All Zones & Programs Status screen, or press the **Next** button to go to the Water Source Status screen.

Water Source Status Screen

When the controller dial is in the **RUN** position and the main Zone Status screen is displayed, press the **Next** button three times to display the Water Source Status screen.

Press the **+** or **-** button to cycle through the water sources on the controller.

The colored box on the left indicates the water source status. Refer to the Status Colors topic on page 32 for an explanation of the colors.

4 Message(s)		RUN	
{Aspen Park}			
12:38:13 PM		FlowStn: <input type="checkbox"/> Connected	
Tue - 7/16/2019		BaseMgr: <input type="checkbox"/> Connected	
		Two-wire: <input type="checkbox"/> 0.84 Amps	
<input type="checkbox"/>	Program 1:	{10 oclock program}	
		Waiting to Water	
	Last Start:	07/16/19 10:00 - Schedule	
	Last Pause:		
	Last Stop:		
	Next Start:	07/17/19 10:00 - Schedule	
	Avg Time:	3:37 (last three)	
	Avg Water:	360.0 gallons (last three)	
<--Previous		Enter for Help	Next-->

The following information is available in the fields:

Month Used: The cumulative total used from this water source during the month.

Budget: The amount of water that can be taken from this water source during the month.

Empty: If an empty condition has been set up for this water source, this field shows OK or EM for empty. If no empty condition exists, the field shows DS for disabled.

Flow Path: This field shows the control point and mainline that are connected to this water source.

4 Message(s)		RUN	
{Aspen Park}			
12:46:10 PM		FlowStn: <input type="checkbox"/> Connected	
Tue - 7/16/2019		BaseMgr: <input type="checkbox"/> Connected	
		Two-wire: <input type="checkbox"/> 0.84 Amps	
<input type="checkbox"/> WS 1:	{Well}	Running	
Month Used: na			
Budget: 100.0			
Empty: OK			
Flow Path: [WS1/FlowStn]			
<--Previous		<input type="button" value="Enter for Help"/>	Next-->

When the Water Source Status screen is displayed, press the **Previous** button three times to return to the Zone Status screen, or press the **Next** button to go to the Control Point Status screen.

Control Point Status Screen

When the controller dial is in the **RUN** position and the main Zone Status screen is displayed, press the **Next** button four times to display the Control Point Status screen.

Press the **+** or **-** button to cycle through the control points on the controller.

The colored box on the left indicates the control point status. Refer to the Status Colors topic on page 32 for an explanation of the colors.

The following information is available in the fields:

MV: The status of the master valve associated with this control point.

Flow: The status of water flowing through this control point.

Pump: If the control point has an assigned pump, this field shows the status. If no pump is assigned, the field shows None.

Pressure: If the control point has an assigned pressure sensor, this field shows the status. If no pressure sensor is assigned, the field shows None.

Month Used: The cumulative total used from this control point during the month.

Flow Path: This field shows the water source and mainline that are connected to this control point.

When the Control Point Status screen is displayed, press the **Previous** button four times to return to the Zone Status screen, or press the **Next** button to go to the Mainline Status screen.

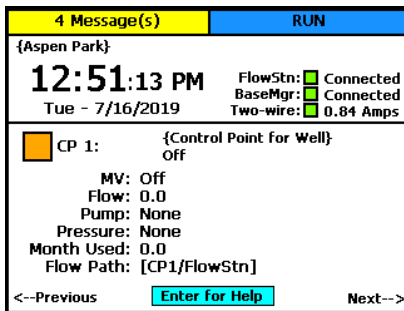

Mainline Status Screen

When the controller dial is in the **RUN** position and the main Zone Status screen is displayed, press the **Next** button five times to display the Mainline Status screen.

Press the **+** or **-** button to cycle through the mainlines on the controller.

The colored box on the left indicates the mainline status. Refer to the Status Colors topic on page 32 for an explanation of the colors.

The following information is available in the fields:

Zones On: The zones that are associated with this mainline.

CPs On: The control points that are associated with this mainline.

Flow: The amount of water in this mainline.

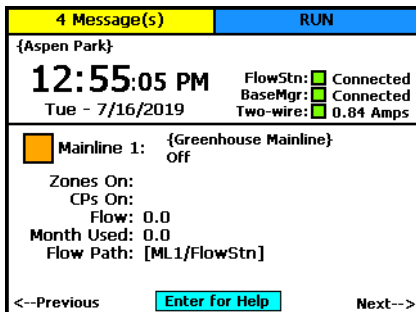











Month Used: The cumulative total used from this mainline during the month.

Flow Path: This field shows the mainline connections.

When the Mainline Status screen is displayed, press the **Next** button to return to the Zone Status screen.

Status Colors

The following colors display on the RUN screen to indicate the status of programs, master valves, flow meters, and zones.

	Idle (watering done)		Disabled
	Active (watering)		Paused
	Waiting to water		Error, Over Budget, Flow/Pressure Faults
	Soaking		Unassigned
	Learn Flow		Off, Rain Delay, Rain jumper activated

On-Screen Reports

The on-screen reports include the results of Test All, the soil moisture graph, the run time graph, and the water used graph.

Note: Refer to Notes, Messages, and Logs on page 109 for the complete description of the on-screen reports.

1. Turn the dial to the **Reports** position.
2. In the **Select Report** field, press the + or – button to display the various reports.

Online Help

At the bottom of every screen, there is a Help option that displays the Online Help. The Online Help describes how to use the buttons to change the functions associated with that screen.

To display the help, press the **Next** or **Previous** button to select the **Help** option at the bottom of a screen, and then press the **Enter** button.

Press the **Next** button to move through the pages of the Online Help.

Press the **Previous** button to back up.

Online Help	Programs
Program Setup	
Program Start Days Setup	
<p>1. Verify that the number displayed in the Program field matches the program that you want to set start days for. If you want to select a different program, press the + or - button to change the program number.</p>	
<i>Press NEXT/PREV for more help, BACK to exit</i>	

Press the **Back** button to return to the controller screen.

The help can be displayed in Spanish. Refer to Selecting the Language for Online Help on page 93.

Power Cycling or Restarting the Controller

If the controller goes into an abnormal state and does not respond, you might need to restart it.

1. Turn the dial to **OFF**.
2. Press and hold the – and + and **Enter** buttons for approximately 5 seconds.
3. After the screen goes blank, release the buttons.
4. Turn the dial to **RUN**. The controller restarts.

Setting the Controller Time and Date

Set or change the controller date and time to match the current time and date. An inaccurate date and time can cause watering events to be missed.

Note: When the controller is connected to BaseManager, the date and time are automatically set.

1. Turn the dial to the **Time & Date** position.
2. In the **Time** field, the hours place is highlighted.
3. Press the + or – button to change the value.
4. Press the **Next** button to move to the minutes place, and then press the + or – button to change the value.
5. Press **Next** to continue moving through the fields, and then press the + or – button to change the value.

Date & Time	
Time	<input type="text" value="8"/> : <input type="text" value="34"/> <input type="text" value="AM"/>
Date	<input type="text" value="11"/> / <input type="text" value="20"/> / <input type="text" value="2017"/>
<input type="button" value="Help"/>	

Note: If you made a change to the time or date and you want to revert to the previous entries, press the Back button.

6. When you have finished making changes, turn the dial to the **RUN** position.

Checking the Firmware Version on Your Controller

Turn the dial to the **Advanced** position.

The version number of the firmware displays at the bottom of the screen.

Firmware updates are free for the life of any Baseline controller as long as the hardware is compatible. Baseline will periodically release firmware updates that enhance the usefulness of our products or fix the occasional bug.

To determine whether the firmware version on your controller is different from the

currently released version, go to the Baseline website (www.baselinesystems.com). Click the **Support** tab, and then click the **Firmware Updates** link in the menu on the left. Click the tab for your product. Review the information on that page, to find out what the current firmware version is and then compare that with the version on your controller.

If you find that an updated firmware version is available and you want to replace the firmware on your controller with the new version, refer to Updating the Controller Firmware on page 100.

Version of
firmware that
is running on
this controller

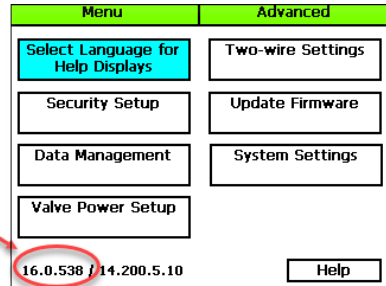

5 – Configuring Devices

After you have finished connecting all your devices, you need to have the controller find those devices so you can assign them.

The devices that you can attach to the BaseStation 3200 have serial numbers. The controller identifies an attached device by its serial number. After you have searched for the attached devices, you assign each serial number to a specific purpose in the controller.

It is a good idea to keep a record of where devices are located and how they are assigned. Zone worksheets are included in the Appendix of this manual. For other devices, you might want to create a list similar to the example below. This information will be helpful when you need to assign these devices to specific uses in the controller.

<u>Device Type</u>	<u>Location</u>	<u>Serial Number</u>	<u>Device Address</u>
Moisture Sensor	Cistern	SB08685	MS1
Moisture Sensor	Soccer field	SB08997	MS2
Flow Meter	On 6" mainline	WF02132	FM1

Note: In BaseManager, you can add a custom description for all devices. These descriptions are visible on the controller and will help you identify devices.

Searching For and Assigning Devices

Before you can configure any devices such as biCoders or biSensors in the controller, the controller must find those devices and assign them to an address. You can connect the following types of biCoders and other two-wire devices directly to the two-wire path:

- Zone biCoders (valve decoders)
- Master valves
- Pump start devices
- Flow meters and sensors
- biSensors (soil moisture sensors)
- Temperature sensors
- Event switches
- Pressure sensors

1. Turn the dial to the **Assign** position.
2. Press the **Next** or **Previous** button to move to the option for the type of device that you want to search for, and then press the **Enter** button.

- Press the + or – button to select **Search** in the left column of the Assign screen.
- Press the **Enter** button to search for devices. The search may take several minutes to complete. You will see a status screen like the one shown here while the search is in progress.

The display shows the number of devices found and the number of ports or addresses available.

Note: To cancel a search in progress, press the Back button.

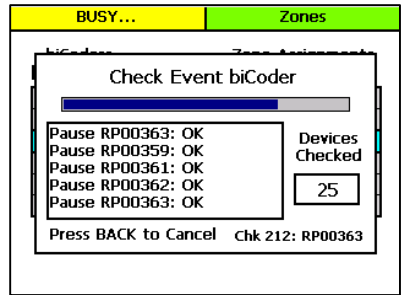

- After the search has finished and the device serial numbers display in the left column, press the + or – button to select any unassigned device serial number.
- Press the **Next** or **Previous** button to move to the **Assignments** column and select an available number.
- Press the **Enter** button to assign the selected device to that number.
- When you have finished making changes, turn the dial to the **RUN** position.

Note: If you need to change your device assignments, refer to Changing Device Assignments on page 40.

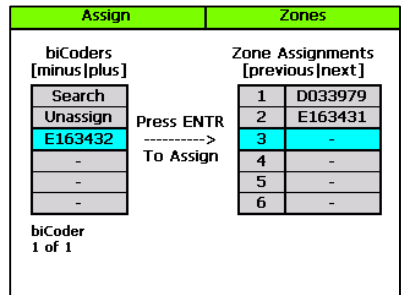

Notes about Assigning biCoders to Zone Numbers

The BaseStation 3200 controller accommodates up to 200 zones, and those zones are identified in the controller with numbers 1 to 200. These numbers are also referred to as “addresses” because they tell the controller where a specific device “lives.”

You can assign **any** valve biCoder serial number to **any** zone number.

You may also wish to reassign and/or reorder certain zones in order to properly combine primary and linked zones in a scheduling group.

The 3200 makes these assignments quick and easy to do, but be sure to document any changes that you make. Failure to properly document assignments can cause confusion and frustration for maintenance staff.

Zone Numbers are Pre-Assigned in R-Series

When you order a conventionally wired BaseStation 3200R controller, it is pre-programmed at the factory so that that terminal 1 is assigned to zone 1, terminal 2 is assigned to zone 2, and so on. You can change these zone numbers to organize scheduling groups, primary, and linked zones to achieve optimal watering behavior.

Note: Baseline recommends that you use the Hydrozone Worksheet on page 125 to plan the conversion from your existing irrigation controller to your new BaseStation 3200.

To change or re-order zone numbers in an R-series unit, perform the steps in the topic on clearing a previous zone number assignment on page 40, and then assign each biCoder serial number to the desired zone number.

Note: The serial numbers for all terminals in 3200R controllers are shown on the label next to the terminals. The serial numbers for terminals in 5200R biCoders are shown on the door label.

Related Topics

Configuring Zone Settings on page 37

Setting Up Start, Stop, Pause Conditions on page 67

Assigning Devices to Control Points on page 80

Assigning Zones to Mainlines on page 80

Assigning biSensor Soil Moisture Sensors to Primary Zones on page 61

Configuring Zone Settings

After you have searched for your biCoders and assigned them to zones, you can configure the settings for each zone.

Before setting up your zones, make sure you understand the following information:

- A zone can be assigned to both a program and a mainline, or just to a program.
 - If a zone is assigned to a program and a mainline, flow from that mainline is used when the program runs.
 - If a zone is not assigned to a mainline, flow is not used. The device associated with the zone runs based on the program schedule. This functionality enables you to add items like lights or pond fill switches to the program and run them at the same time as the irrigation.
- One zone can be assigned in multiple programs, and it can have different settings in each program. Consider how you want the zone to run in the program shown in the upper-left corner of the Zones screen.
- Zones will not run automatically until you complete the program settings. Refer to Setting Up Programs on page 48.
- Zones that are intended for irrigation will not water until they are assigned to their appropriate mainlines. Refer to Assigning Zones to Mainlines on page 80.

Note: The BaseStation 3200 supports 200 standard zones.

1. Turn the dial to the **Zones** position. The Zones screen displays for the first zone.

2. In the **Zone** field press the + or – button to change the number to the zone that you want to configure.

3. Press the **Next** button to move to the **Zone Mode** field. Press the + or – button to change the value in the field to one of the following settings:

Note: If you change the mode of a zone to Primary or from Primary to another mode, you will potentially affect the programming of other zones. For example, a primary zone has 20 linked zones. If you change the mode of the primary zone to linked or timed, the links to the 20 zones will be broken.

Zones	
{Turf Sprays North}	Zone [VB00009] 2
1	{South Park MPs}
Program	Zone Mode Timed
	Water Time (h:mm) 0:45
	Cycle Time (h:mm) 0:15
	Soak Time (h:mm) 0:30
	Enabled YES
	Use ET Deficit Water Times NO
Programs: 1	Help

- **Primary** – The zone within a scheduling group that all other zones are linked to. Changing the programming on this zone will adjust the programming on all linked zones, resulting in saved time and consistency. If you are using a biSensor, the primary zone is the zone where the sensor is located.
- **Linked** – Within a zone group, there is one primary zone and all other zones are then “linked” to the primary and will get their programming information from the primary (water time, program, schedule, etc.)
- **Timed** – Any zone programmed to water on a time/day schedule, rather than on a smart irrigation schedule

4. Press the **Next** button to move to the **Water Time** field.

- If you want to increase the value in the hours place, press the + button.
- If you want to change the value in the minutes place, press the **Next** button, and then press the + or – button.

Note: When you change the water time setting for a linked zone, notice that a percentage displays to the left of the Water Time field. This percentage compares the new value with the value in the Water Time field for the Primary zone and establishes a tracking ratio. The ratio will be maintained when changes are made to the primary zone’s water time.

Tip: Let the controller calculate the cycle time and soak time settings for you. Press the Next button to move to the minutes placeholder in the Soak Time field, and then press the Back button. The controller divides the time in the Water Time field by 3. This value is used for the cycle time and the default soak time is 30 minutes.

5. Press the **Next** button to move to the **Cycle Time** field. If you are using soak cycles for this zone, the cycle time defines the duration of each watering cycle interspersed with soak times.

Note: You cannot change the cycle time setting for a linked zone.

6. Press the **Next** button to move to the **Soak Time** field. If you are using soak cycles for this zone, the soak time defines the duration of each soaking cycle interspersed with watering times.

Note: You cannot change the soak time setting for a linked zone.

7. Press the **Next** button to move to the **Enabled** field. Press the + or – button to toggle the value in the field between **YES** and **NO**.

Note: If you want to prevent a zone from running, you can temporarily set the Enabled field to NO. When you want the zone to run again, return to the Zones dial position and change this setting to YES. This setting disables the zone in all programs.

8. Press the **Next** button to move to the **Use ET Deficit Water Times** field. Press the + or – button to toggle the value in the field between **YES** and **NO**.

IMPORTANT NOTE! You can enable ET in the BaseStation 3200 controller, but you must also have a weather-station connected to BaseManager and assigned to the controller in BaseManager. Selecting this option in the controller has no effect unless you complete these additional steps in BaseManager. Also be aware that when you enable a zone to use WeatherAccess in BaseManager, the Use ET Deficit Water Times option is automatically selected in the controller.

9. The number in the **Program** field in the upper-left corner of the screen indicates what program these zone settings are for. A zone can be removed from a program, assigned to a different program, or assigned to more than one program. If you want to make a change to how the zone is assigned to a program, perform one of the following options; otherwise, skip to step 11 of this procedure.

Note: To move to the Program field, press the Next or Previous button.

- To remove the zone from the current program, press the **Previous** button to return to the **Water Time** field, and then press the – button to remove the watering time in the field.
- To assign the zone to a different program, perform the previous task to remove the zone from the current program. Move to the **Program** field, and press the + or – button to change the number to the new program that you want the zone to be assigned to.
- To assign the zone to an additional program, move to the **Program** field, and press the + or – button to change the number to the additional program that you want the zone to be assigned to. Repeat steps 3 – 7 to configure the zone settings in the new program.

Note: The lower-left corner of the screen shows what programs the zone is assigned to.

10. After you have configured the settings for the current zone, perform one of the following options:
 - To configure another zone, press the **Enter** button until the number of the zone that you want to configure displays in the **Zone** field at the top of the screen. Repeat steps 3 – 9.
 - When you have finished making changes, turn the dial to the **RUN** position.

IMPORTANT NOTE! Zones that are intended for irrigation will not water until they are assigned to their appropriate mainlines. Refer to Assigning Zones to Mainlines on page 80.

Adjusting the Valve Power Level for a biCoder

If your irrigation system uses solenoids that have different power requirements, you can adjust the valve power level of the biCoders that are attached to the zones associated with these solenoids. Typically, you will perform this task under the guidance of Baseline Support.

Note: You only need to perform this procedure when the current read by the biCoder is less than .110 Amps.

1. Turn the dial to the **Advanced** position.
2. Press the **Next** or **Previous** button to move to the **Valve Power Setup** option, and then press the **Enter** button.
3. In the **Zone biCoder** field, press the **+** or **-** button to select the zone and serial number of the biCoder that you want to adjust.
4. Press the **Next** button to move to the **Valve Drive Power** field, and then press the **+** or **-** button to change the value.

You can adjust the valve power for any biCoder from a minimum of 1 to a maximum of 3. If a biCoder does not support this feature, the word "Fixed" displays in the Valve Drive Power field.

5. Press the **Enter** button to change the setting.
6. When you have finished making changes, turn the dial to the **RUN** position.

Changing Device Assignments

As you maintain your irrigation system over time, you may need to change how your devices are assigned. Perhaps you replace a device with a new one or you move a device to another part of your irrigation system.

You might also want to reassign your biCoders to different zone numbers in order to accurately represent the layout of your irrigation system.

The BaseStation 3200 has the following options for changing device assignments:

- Unassigning a device – This method removes all the programming that is associated with the device.
- Replacing an assigned device with a new device – This method retains the programming and associates it with the new device.

Unassigning a Device

CAUTION! Unassigning a device removes all the programming associated with the device. To save the programming, refer to Replacing an Assigned Device with a New Device on page 41.

1. Turn the dial to the **Assign** position.
2. Press the **Next** or **Previous** button to move to the option for the type of device that you want to unassign, and then press the **Enter** button.

- Press the + or – button until **Unassign** is highlighted in the left column.
- Press the **Next** button to move to the device assignments column on the right.
- Press the **Next** or **Previous** button to select the device that you want to unassign.
- Press the **Enter** button. A message displays warning that programming will be removed.
- To unassign the device, press the **Enter** button again. If you want to cancel, press any other button.

		Assign	
biCoders [minus plus]		Zone Assignments [previous next]	
Help		2	E012472
Search		3	Q006641
Unassign	Press ENTR <----- To Assign	4	Q006642
D003329		5	Q006643
Q006644		6	-
VA00001		7	-
		Status = OK, 0.24 Amps	
Total biCoders/Ports = 6 / 33			

Note: If you cleared a zone number assignment so you can reassign certain zones in order to properly combine primary and linked zones in a scheduling group, return to Configuring Zone Settings (on page 37) to complete the assignments.

- When you have finished making changes, turn the dial to the **RUN** position.

Replacing an Assigned Device with a New Device

If you need to replace a device in the field, you can replace the device in the controller with the new device. Replacing a device copies all the programming associated with the original device to the new device.

This option is especially useful if you need to replace the biCoder on a Primary Zone. By replacing the assigned device with a new device, all your primary zone configuration and linked zone settings will be copied to the new device.

- Turn the dial to the **Assign** position.
- Press the **Next** or **Previous** button to move to the option for the type of device that you want to replace, and then press the **Enter** button.
- Press the + or – button to select **Search** in the left column, and then press **Enter**.
- Press the + or – button to select the serial number of the new device that you want to put in place of an assigned device.
- Press the **Next** or **Previous** button to move to the **Assignments** column and select the number and serial number of the device that you want to replace.
- Press the **Enter** button to replace the selected device with the new device.
- When you have finished making changes, turn the dial to the **RUN** position.

		Assign	
biCoders [minus plus]		Zone Assignments [previous next]	
Unassign		199	-
D003329		200	-
E012472	Press ENTR -----> To Assign	1	E012471
Q006642		2	Q006641
Q006644		3	Q006643
VA00001		4	-
biCoder 2 of 30		Status = OK, 0.24 Amps	
Total biCoders/Ports = 6 / 33			

6 – Initial Programming

After you have assigned your devices as described in the previous section, you are ready to start the initial programming on your BaseStation 3200 controller. A program on the BaseStation 3200 controller is simply used for scheduling. Zones that are intended for irrigation will not water until they are assigned to their appropriate mainlines. You can create programs for the following functions:

- To tell irrigation zones when to turn on and off
- To open a valve that fills a pond or a fountain
- To turn lights on and off
- To lock or unlock doors and gates

When you are setting up an irrigation program, keep in mind that the BaseStation 3200 provides the following methods for controlling the amount of water that is applied to a zone:

- Watering based on zone runtime and program schedule
- Watering based on a soil moisture strategy
- Watering based on a historical calendar
- Watering based on WeatherAccess™

Note: If you are using a soil moisture sensor, be sure to read the information about setting up soil moisture sensor based watering including the information about the watering strategies on page 64.

Setting Up a Time-Based Program

IMPORTANT NOTE! Even if you are planning to use the soil moisture sensor watering strategy or weather-based watering to control how much water to apply, you still need to configure the runtime and mode settings for your zones.

Setting Up a Timed Zone

By default, all zones are set up as timed. If the mode of a zone was changed to linked or primary, you can use this procedure to change the zone mode back to timed.

Implications for changing a zone within a scheduling group to timed:

- If you change a zone in the middle of your scheduling group from linked to timed, the linked zones will continue to water as a group, but the zone that was changed to timed will now water on a timed schedule.
- If you change a primary zone to timed, all zones that are linked to that primary zone will be changed to timed.

To set up a timed zone

1. Turn the dial to the **Zones** position. The Zones screen displays for the first zone.

2. In the **Zone** field, press the + or – button to select the zone that you want to set up as timed.

Note: The serial number of the biCoder assigned to this zone displays next to the Zone field. Descriptions from BaseManager display within the curly braces. For example, {South Park MPs}.

3. Press the **Next** button to move to the **Zone Mode** field, and then press the + or – button until **Timed** displays in the field.

Zones	
{Turf Sprays North}	
<input type="text" value="1"/>	Zone [VB00009] <input type="text" value="2"/>
Program	{South Park MPs}
	Zone Mode <input type="text" value="Timed"/>
Water Time (h:mm)	<input type="text" value="0:45"/>
Cycle Time (h:mm)	<input type="text" value="0:15"/>
Soak Time (h:mm)	<input type="text" value="0:30"/>
	Enabled <input type="text" value="YES"/>
Use ET Deficit Water Times	<input type="text" value="NO"/>
Programs: 1	<input type="button" value="Help"/>

4. Press the **Next** button to move to the **Water Time** field.

- To change the value in the hours place, press the + button.
- To change the value in the minutes place, press the **Next** button, and then press the + or – button.

Tip: Let the controller calculate the cycle time and soak time settings for you. Press the Next button to move to the minutes placeholder in the Soak Time field, and then press the Back button. The controller divides the time in the Water Time field by 3. This value is used for the cycle time and the default soak time is 30 minutes.

5. Press the **Next** button to move to the **Cycle Time** field. If you are using soak cycles for this zone, the cycle time defines the duration of each watering cycle interspersed with soak times.

6. Press the **Next** button to move to the **Soak Time** field. If you are using soak cycles for this zone, the soak time defines the duration of each soaking cycle interspersed with watering times.

7. Press the **Next** button to move to the **Enabled** field, and then press the + or – button to toggle between YES and NO. Set the value to **YES**.

8. Press the **Next** button to move to the **Use ET Deficit Water Times** field. Press the + or – button to toggle the value in the field between **YES** and **NO**.

IMPORTANT NOTE! You can enable ET in the BaseStation 3200 controller, but you must also have a weather-station connected to BaseManager and assigned to the controller in BaseManager. Selecting this option in the controller has no effect unless you complete these additional steps in BaseManager. Also be aware that when you enable a zone to use WeatherAccess in BaseManager, the Use ET Deficit Water Times option is automatically selected in the controller.

9. Verify that the number displayed in the **Program** field in the upper-left corner of the screen matches the program in which you want to set up the timed zone.

- If you want to set up the timed zone in a different program, press the **Next** button to move to the **Program** field, and then press the + or – button to change the program number.

- To remove the zone from the current program, press the **Previous** button to return to the **Water Time** field, and then press the – button to remove the watering time in the field.
10. After you have configured the settings for the current zone, perform one of the following options:
 - To configure another zone, press the **Enter** button until the number of the zone that you want to configure displays in the **Zone** field at the top of the screen. Repeat steps 3 – 10.
 - When you have finished making changes, turn the dial to the **RUN** position.
- IMPORTANT NOTE!** Zones that are intended for irrigation will not water until they are assigned to their appropriate mainlines. Refer to Assigning Zones to Mainlines on page 80.

Setting Up a Primary Zone

A primary zone is the zone within a scheduling group that all other zones in the group are linked to. Changing the programming on the primary zone will adjust the programming on all linked zones, resulting in consistency and efficiency. If you are using a biSensor, the primary zone is the zone where the sensor is located.

Note: The primary zone in a program always runs first.

Prerequisites

- biCoders have been assigned to zones.
- If you are using soil moisture sensors, they have been installed and assigned in the controller.
- You know the number of the zone that waters the area where the soil moisture sensor is installed.

To assign a primary zone

1. Turn the dial to the **Zones** position.
2. Verify that the number displayed in the **Program** field matches the program in which you want to set up the primary zone. If the zone is enabled in multiple programs and you want to set up the primary zone in a different program, press the **Previous** button to move to the **Program** field, and then press the + or – button to change the program number.

Note: A zone can be a primary zone in more than one program, but each program can only have one primary zone.

3. Press the **Next** button to move to the **Zone** field, and then press the + or – button to select the zone that you want to assign as a primary zone.
4. Press the **Next** button to move to the **Zone Mode** field.

5. Press the + or – button until **Primary** displays in the **Zone Mode** field.

Note: If you change the mode of a zone to Primary or from Primary to another mode, you will potentially affect the programming of other zones. For example, a primary zone has 20 linked zones. If you change the mode of the primary zone to linked or timed, the links to the 20 zones will be broken.

6. Repeat steps 2 – 5 for each zone that you want to set as Primary.

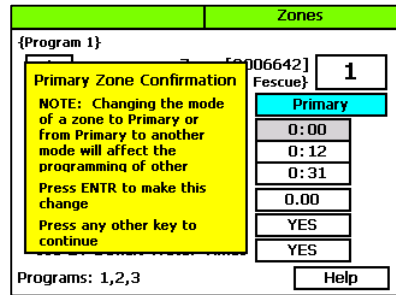

7. When you have finished making changes, turn the dial to the **RUN** position.

Linking Zones (Creating a Scheduling Group)

To make programming easier and more structured, the BaseStation 3200 provides a way to group zones that have similar watering requirements. You create a scheduling group by designating a zone within the group as the primary zone, and then you configure the other zones in the group as linked. If you change the settings for the primary zone, those changes are automatically applied to the linked zones. For example, if your group has 10 zones, you only need to change the settings for the primary zone, and then all the changes will be automatically applied to the other 9 zones.

1. Perform the procedure in Setting Up a Primary Zone (on page 44) first.
2. Turn the dial to the **Zones** position.
3. Verify that the number displayed in the **Program** field in the upper-left corner of the screen matches the program in which you want to set up the scheduling group. If the zone is enabled in multiple programs and you want to set up the scheduling group in a different program, press the **Previous** button to move to the **Program** field, and then press the + or – button to change the program number.

Note: A zone can be a primary zone in more than one program.

4. Press the **Next** button to move to the **Zone** field, and then press the + or – button to select the zone that you want to link.
5. Press the **Next** button to move to the **Zone Mode** field.
6. Press the + button to change the entry in the field so it shows **Linked-#**.
7. To continue linking zones, press the **Enter** button until the number of the zone that you want to link displays in the **Zone** field at the top of the screen.
8. Repeat steps 6 and 7 until you have linked all the zones in the group to the primary zone for that group.
9. When you have finished making changes, turn the dial to the **RUN** position.

Adjusting the Water Time Tracking Ratio of Linked Zones

You can change the water time tracking ratio of a linked zone in order to allow different water times for zones within a group of linked zones. When the tracking ratio of a linked zone is set to 75% of the primary, the zone will run for that percentage of the water time of the primary zone (for example, if the primary zone is set to water for 60 minutes and the linked zone tracking ratio is set to 75%, the linked zone will water for 45 minutes because 75% of 60 is 45). If you change the water time for the primary zone, each linked zone will be adjusted according to its tracking ratio value.

1. Turn the dial to the **Zones** position.

2. Verify that the number displayed in the **Program** field matches the program in which you want to adjust the tracking ratio. If the zone is enabled in multiple programs and you want to adjust the tracking ratio in a different program, press the **Previous** button to move to the **Program** field, and then press the + or – button to change the program number.

3. Press the **Next** button to move to the **Zone** field, and then press the + or – button to select the zone that you want to adjust the water time tracking ratio for.

Zones	
{Shrub Beds}	Zone [VB00009] <input type="text" value="2"/> {South Park MP's}
Program	Zone Mode <input type="text" value="Linked-1"/>
	Tracking Ratio <input type="text" value="75 %"/>
	Cycle Time (h:mm) <input type="text" value="0:15"/>
	Soak Time (h:mm) <input type="text" value="0:40"/>
	Enabled <input type="text" value="YES"/>
	Use ET Deficit Water Times <input type="text" value="NO"/>
Programs: 1,2	<input type="button" value="Help"/>

4. Press the **Next** button to move to the **Zone Mode** field. Make sure the field shows **Linked-#**.

5. Press the **Next** button to move to the **Tracking Ratio** field.

6. Press the + or – button to change the percentage in the field.

7. To adjust the water time tracking ratio for other zones, press the **Enter** button until the number of the zone that you want to adjust displays in the **Zone** field at the top of the screen.

8. Repeat steps 3 through 7 until you have adjusted the water time tracking ratio for other zones in the group, as needed.

9. When you have finished making changes, turn the dial to the **RUN** position.

Using Soak Cycles

Because each type of soil has a different rate at which it can absorb water, you should set up the cycle time and soak time (“soak cycles”) for your zones to ensure that water soaks into the soil instead of being wasted. For example, if you are applying water at 0.4 inch per hour to an area of clay soil that can only absorb water at 0.2 inch per hour, the water that does not soak into the soil will either run off or evaporate.

The settings for a 60-minute water time are shown in this example screen. Primary zone 1 waters for 20 minutes, and then allows that water to soak in for 40 minutes. While zone 1 is soaking, other zones

Zones	
{Shrub Beds}	Zone [VA00005] <input type="text" value="1"/> {North Park MP's}
Program	Zone Mode <input type="text" value="Primary"/>
	Water Time (h:mm) <input type="text" value="1:00"/>
	Cycle Time (h:mm) <input type="text" value="0:20"/>
	Soak Time (h:mm) <input type="text" value="0:40"/>
	Enabled <input type="text" value="YES"/>
	Use ET Deficit Water Times <input type="text" value="NO"/>
Programs: 1,2	<input type="button" value="Help"/>

can run. After the 40 minutes soak time, zone 2 will be allowed to run another 20 minutes after any zone that is currently running finishes.

With these settings, zone 1 completes its 1 hour of watering in three, 20-minute segments, with at least a 40 minute soak time between them.

When there are many zones in a program, zones will be cycled and soaked until all have been completed. Zones that have completed their soak cycles are prioritized higher than zones that are still waiting to water so the first zones to start watering will be the first to complete.

It is especially useful to enable soak cycles when you are watering a slope.

To set up soak cycles for a zone

1. Turn the dial to the **Zones** position.
2. Verify that the number displayed in the **Program** field matches the program in which you want to set up the soak cycles. If the zone is enabled in multiple programs and you want to set up the soak cycles in a different program, press the **Previous** button to move to the **Program** field, and then press the + or – button to change the program number.
3. Press the **Next** button to move to the **Zone** field, and then press the + or – button to select the zone that you want to set up the soak cycles for.

Note: When you set the soak cycle times for a primary zone, the soak cycles will also be set for all linked zones. The cycle time for linked zones is calculated based on the tracking ratio of the primary zone cycle time. The soak times will be the same as that of the primary zone.

4. Press the **Next** button to move to the **Water Time** field.
 - To change the value in the hours place, press the + button.
 - To change the value in the minutes place, press the **Next** button, and then press the + or – button.

Note: When you change the water time setting for a linked zone, notice that a percentage displays to the left of the Water Time field. This percentage compares the new value with the value in the Water Time field for the Primary zone and establishes a tracking ratio. The ratio will be maintained when changes are made to the primary zone's water time.

Tip: Let the controller calculate the cycle time and soak time settings for you. Press the Next button to move to the minutes placeholder in the Soak Time field, and then press the Back button. The controller divides the time in the Water Time field by 3. This value is used for the cycle time and the default soak time is double the cycle time.

5. Press the **Next** button to move to the **Cycle Time** field. If you are using soak cycles for this zone, the cycle time defines the duration of each watering cycle interspersed with soak times.
 - To change the value in the hours place, press the + button.
 - To change the value in the minutes place, press the **Next** button, and then press the + or – button.

Note: You cannot change the cycle time setting for a linked zone.

6. Press the **Next** button to move to the **Soak Time** field. If you are using soak cycles for this zone, the soak time defines the duration of each soaking cycle interspersed with watering times.
 - To change the value in the hours place, press the + button.
 - To change the value in the minutes place, press the **Next** button, and then press the + or – button.

Note: You cannot change the soak time setting for a linked zone.
7. When you have finished making changes, turn the dial to the **RUN** position.

To disable soak cycles

1. Turn the dial to the **Zones** position.
2. Verify that the number displayed in the **Program** field matches the program in which you want to disable the soak cycles. If the zone is enabled in multiple programs and you want to disable the soak cycles in a different program, press the **Previous** button to move to the **Program** field, and then press the + or – button to change the program number.
3. Press the **Next** button to move to the **Zone** field, and then press the + or – button to select the zone that you want to disable the soak cycles for.

Note: When you disable the soak cycle for a primary zone, the soak cycle is disabled for all linked zones. The controller skips the linked zones when you press the + or – button to select a zone.
4. Press the **Next** button to move to the **Cycle Time** field, and then press the **Back** button to change the value in the field to 0:00.
5. Press the **Next** button to move to the **Soak Time** field, and then press the **Back** button to change the value in the field to 0:00.
6. When you have finished making changes, turn the dial to the **RUN** position.

Setting Up Programs

The BaseStation 3200 supports 99 programs. The controller identifies each program with a number.

In many irrigation controllers, you set up the water times and the watering schedules in the programs, but in the BaseStation 3200, water times are configured for the individual zones, and a program is simply the schedule for when the associated zones will run. Also keep in mind that you can set up programs to control lighting and other functions in addition to watering.

The schedule has the following components:

Start Times – Each program can have up to 8 start times in a 24-hour period. Start times are set in 5 minute increments from the top of the hour.

Start Days – If there are watering restrictions in your area, you might be able to use one of the pre-configured day interval options in the controller to comply with the restrictions. Options are a 7-day schedule, even days of the month, odd days of the month, odd days of the month excluding the

31st day of the month, fixed intervals, and historical ET calendar (explained in the topic on setting up historical calendar watering for a program on page 51).

Water Windows – Water windows are used to select when watering will or will not be allowed. You can configure water windows on a weekly basis (having the same water window settings for each day of the week) or on a daily basis, where you can set each day of the week for a specific water window schedule.

Concurrent Zones – Concurrent zones are the number of zones (valves) that can be operated at the same time – typically limited by electrical and hydraulic capacity of the system. You can set up the concurrent zones on a per program basis, and you can also have concurrent zones automatically managed using a flow device. You must also set the total number of concurrent zones for the controller.

Booster Pumps – If a group of valves located near the end of a pipe run needs more pressure to operate normally, you can assign a pump to a program so it will run with the program.

Advanced Setup

- **Priority** – Each program can be given a watering priority (1 – 99, where 1 is the highest priority). When start events are hit, the program with the highest priority gets first call on the water and time. A higher priority program will preempt lower priority programs and will run to completion before the lower ones. If all programs are set to the same priority number, they run in order of the program number.
- **Ignore Global Settings** – If a program is used to operate lights or fill a fountain, you can select this option to have the program ignore global controller settings such as a rain delay. This way, the program continues to run even when the controller is in rain delay mode.
- **Ignore Concurrent Zones** – If a program is used to operate lights or fill a fountain, you can select this option to have the program ignore the concurrent zone settings. This way, the program continues to run even when the maximum number of valves are also operating at the same time.

To set up the start times for a program

1. Turn the dial to the **Programs** position.
2. The **Program Start Times Setup** option should be highlighted. If it is not highlighted, press the **Next** button to select it.
3. Press the **Enter** button. The Start Times screen displays.
4. Verify that the number displayed in the **Program** field matches the program that you want to set start times for. If you want to select a different program, press the **+** or **-** button to change the program number.
5. Press the **Next** button to move to the start times grid.
6. Press the **+** or **-** button to set the time in the first cell.

Start Times	Programs		
Program <input type="text" value="1"/> {Program 1}			
1:00A	-	-	-
-	-	-	-
			<input type="button" value="Help"/>

7. Press the **Next** button to move to the next cell in the start times grid, and then press the **+** or **-** button to set additional start times as needed.
8. After you have configured the start times for the current program, perform one of the following options:
 - To configure start times for another program, press the **Enter** button until the number of the program that you want to configure displays in the **Program** field at the top of the screen. Repeat steps 5 – 7.
 - When you have finished making changes, turn the dial to the **RUN** position.

To set up the start days for a program

1. Turn the dial to the **Programs** position.
2. Press the **Next** button to select the **Program Start Days Setup** option, and then press the **Enter** button. The Start Days screen displays.
3. Verify that the number displayed in the **Program** field matches the program that you want to set start days for. If you want to select a different program, press the **+** or **-** button to change the program number.
4. Press the **Next** button to move to the **Schedule Type** field where you can select one of the following intervals:

Start Days	Programs														
Program {Program 1} 1															
Schedule Type Days of the Week															
Days of the Week <table style="margin-left: auto; margin-right: auto; border-collapse: collapse;"> <tr> <td style="padding: 0 5px;">S</td> <td style="padding: 0 5px;">M</td> <td style="padding: 0 5px;">T</td> <td style="padding: 0 5px;">W</td> <td style="padding: 0 5px;">T</td> <td style="padding: 0 5px;">F</td> <td style="padding: 0 5px;">S</td> </tr> <tr> <td style="border: 1px solid black; text-align: center;">Y</td> <td style="border: 1px solid black; text-align: center;">Y</td> <td style="border: 1px solid black; text-align: center;">Y</td> <td style="border: 1px solid black; text-align: center;">Y</td> <td style="border: 1px solid black; text-align: center;">Y</td> <td style="border: 1px solid black; text-align: center;">Y</td> <td style="border: 1px solid black; text-align: center;">Y</td> </tr> </table>		S	M	T	W	T	F	S	Y	Y	Y	Y	Y	Y	Y
S	M	T	W	T	F	S									
Y	Y	Y	Y	Y	Y	Y									
Help															

- **Days of the Week** – After you select the Days of the Week option, press the **Next** button to set up the weekdays when you want the program to start. By default, the boxes for the days of the week are marked with a Y (Yes), which indicates that the program will start every day. If you want to change a start day, press the **Next** button to select the day, and then press the **+** or **-** button to change the setting.
- **Interval Days** – This option enables you to set up a custom interval for the program start days. Press the **Next** button to move to the **Watering Interval Days** field, and then press the **+** or **-** button to change the setting. The next start date is calculated and entered in the Next Start field. If you want to change the next start date, press the **Previous** button to select the **Next Start** field, and then press the **-** button to change the date.

Note: You can decrease the start date, but you cannot increase it.

- **Even Days** – Select **Even** to start the program only on the even numbered days of the month.
- **Odd Days** – Select **Odd** to start the program only on the odd numbered days of the month.
- **Odd Skip 31** – Select **Odd Skip 31** to start the program only on the odd numbered days of the month, but skip the 31st day in order to maintain an every-two-day schedule when crossing to a new month.
- **Historical Calendar** – Using the **Historical Calendar** watering schedule you can set up custom start day intervals for the first half and second half of every month of the year. This watering schedule works best in regions where landscapes are irrigated all year.

Refer to the topic on setting up program start days based on a historical calendar on page 51.

5. After you have configured the start days for the current program, perform one of the following options:
 - To configure start days for another program, press the **Enter** button until the number of the program that you want to configure displays in the **Program** field at the top of the screen. Repeat step 4.
 - When you have finished making changes, turn the dial to the **RUN** position.

Note: A program that is started on one day will continue to run until it completes, even if it needs to continue to the next day, which may or may not be a watering day. For example, if a 6-hour program starts at 10 PM on Monday, it will finish at 4 AM on Tuesday, even if Tuesday is not a watering day.

To set up program start days based on a historical calendar

In the BaseStation 3200, one of the Start Day modes for a program is Historical Calendar. A historical calendar uses ET (evapotranspiration) data to predict how frequently you will need to irrigate over the course of an entire year. ET refers to the loss of moisture from the soil by evaporation and by the transpiration of plants. Factors such as air temperature, humidity, solar radiation, and wind speed affect the rate at which ET occurs. Scientists with the National Oceanic and Atmospheric Administration (NOAA) continuously monitor climate data in all regions of the United States. When this data is averaged over a 30 year period, historical ET values are generated for each month of the year.

The Historical Calendar mode enables you to set up a watering schedule for the entire year that compensates for seasonal changes without your having to adjust times and frequency multiple times throughout the year.

If you set up a water time that applies $\frac{1}{2}$ - $\frac{3}{4}$ inch of water, and then you change the frequency of watering based on the historical ET needs for your area, the controller will water deeply and less frequently. This watering method encourages your plants to grow deep roots.

Prerequisites

- Set zone water times that will apply $\frac{1}{2}$ - $\frac{3}{4}$ inch of water during each watering cycle.
- Get the historical ET deficit data for your region. Consult with your local Agricultural Cooperative Extension office – you can find a national register of the extension offices at: <https://offices.sc.egov.usda.gov/locator/app>
- Split each month of the year in half and determine how frequently you will need to water in order to replace the amount of moisture used by your plant material since the last irrigation event. Use the ET deficit data to determine the watering frequency.

Note: If you combine the Historical Calendar mode with the upper limit watering strategy using biSensors, you will have a very effective watering schedule. The biSensor will monitor the soil moisture in real-time and compensate for non-historical weather behavior by making fine adjustments to the water time.

Programming Instructions

1. Turn the dial to the **Programs** position.
2. Press the **Next** button to select the **Program Start Days Setup** option, and then press the **Enter** button. The Start Days screen displays.
3. Verify that the number displayed in the **Program** field matches the program that you want to set the historical calendar watering schedule for. If you want to select a different program, press the + or – button to change the program number.

4. Press the **Next** button to move to the **Schedule Type** field. Press the + button to move through the options, and then stop when **Historical Cal** is displayed in the field.

This pair of cells represents the month of January. The interval for January 1 -15 is in the first cell and the interval for January 16 - 31 is in the second cell. The other paired cells represent the remaining months of the year in order.

Start Days		Programs											
		Program {Program 1}		1									
		Schedule Type		Historical Cal									
		Next Start >=		11/27/17									
		Historical Calendar						Date: JAN 1-15					
7	6	6	6	4	3	3	3	3	2	2	2	2	2
2	2	2	2	3	3	3	4	6	6	6	7		
Help													

5. Press the **Next** button to move to the **Next Start** field. The date is calculated based on today's date and the preconfigured interval.
6. Press the **Next** button to move to the **Calendar** grid. The grid displays 12 pairs of cells that represent the months of the year. In each pair, the first cell represents the first half of the month and the second cell represents the second half of the month. A number in a cell represents the day interval for the designated time frame. Perform any of the following options in the Calendar grid:
 - To increase or decrease the day interval in the selected cell, press the +/- buttons.
 - To turn watering off in the selected cell, press the – button to set the number to zero.
 - To move to and select a different cell, press the **Next** or **Previous** button.
7. When you have finished configuring the Historical Calendar settings, turn the dial to the **RUN** position.

Note: If you set up multiple programs to use the Historical Calendar settings, be sure to set the program start dates so the interval is staggered. Refer to Setting Up the Start Days for a Program on page 50.

To set up the water windows for a program

Water windows tell the controller when watering is allowed and not allowed. You can set water windows for either Weekly (shown on illustration below) or daily – when moving from weekly to daily, the weekly settings are copied to each day of the week.

Selecting daily water windows gives you hourly control of watering for each day of the week, and for each program. A white square will pause watering for that hour, or keep a start time from starting a program.

1. Turn the dial to the **Programs** position.
2. Press the **Next** button to select the **Program Water Windows Setup** option. The Water Windows screen displays.
3. Press the **+** or **-** button to select the program that you want to set up water windows for.
4. Press the **Next** button to move to the **Water Window Type** field, and then press the **+** or **-** button to select either Weekly or Daily.

Note: If you use “Weekly” to set up the water windows and then you decide to convert to “Daily,” the weekly settings are copied to each day of the week.

Water Windows		Programs										
Program		1										
{Program 1}												
Water Window Type		Weekly										
Day of the Week		All Week										
ENTR to set All hours to		OFF										
Allow Watering <input type="checkbox"/>		Do Not Allow Watering <input type="checkbox"/>										
AM	12	1	2	3	4	5	6	7	8	9	10	11
PM	12	1	2	3	4	5	6	7	8	9	10	11
												Help

Selecting daily water windows gives you hourly control of watering for each day of the week and for each program.

5. Press the **Next** button to move to the **Day of the Week** field. If you are using the “Weekly” Water Window Type, you cannot change the setting in this field, but if you are using “Daily,” press the **+** or **-** button to display the day of the week that you want to set up water windows for.
6. Press the **Next** button to move to the **ON/OFF** field.
 - If the cells in the grid are blue (allow watering), the field displays **OFF**. Press the **Enter** button to turn all the water windows off.
 - If the cells in the grid are white (do not allow watering), the field displays **ON**. Press the **Enter** button to turn all the water windows on.
7. To make changes to the individual cells in the grid, press the **Next** button. The color of the number in the first cell of the grid changes to red (indicating that you can change the setting in that cell).
 - To change the water setting for the time/day represented by that grid, press the **+** button.
 - To move to next cell in the grid, press the **Next** button.

Note: If you want to set up daily water windows, start by setting a basic profile in weekly mode, and then change to daily mode to modify specific days (like a mow day). Pressing the Enter button will maintain the current selected field and advance through the days of the week.

8. When you have finished making changes, turn the dial to the **RUN** position.

To set up a booster pump for a program

If a group of valves located near the end of a pipe run needs more pressure to operate normally, you can assign a pump to a program so it will activate whenever there is a zone running on this program.

1. Turn the dial to the **Programs** position.
2. Press the **Next** button to select the **Booster Pumps Program Setup** option. The Booster Pumps screen displays.
3. In the **biCoder** field, press the + or – button to select the number of the master valve or pump that you want to assign.
4. Press the **Next** button to move to the **Use As Booster Pump** field, and then press the + or – button to select **YES**. The Select Programs with Booster Pump grid displays.
5. Press the **Next** button to move to the **Select Programs with Booster Pump** grid, and then press the + or – button to select the number of the program that you want to assign a booster pump to.
6. Press the **Next** button to move to the right column of the **Select Programs with Booster Pump** grid, and then press the + or – button to select **Yes**.
7. If you want to assign the booster pump to another program, press the **Previous** button to move to the left column of the **Select Programs with Booster Pump** grid, and then press the + or – button to select the program number.
8. Repeat step 6.
9. When you have finished making changes, turn the dial to the **RUN** position.

Booster Pumps	Programs
biCoder: DMV0216	MV 1
{2 Hydro Meter MV 1}	
Use As Booster Pump	YES
Select Programs with Booster Pump	- -
{Turf Sprays North}	1 Yes
	2 No
	3 No
Booster Pump: MV1 / DMV0216	
	Help

To set up concurrent zones for a program

Managers of irrigation systems with many zones often find it challenging to water all zones within an allowed schedule. When an irrigation system has adequate pressure/flow and electrical capacity, the system could run more than one zone at a time to reduce the total amount of time it takes for the watering schedule to complete.

In another scenario, zones might be used to turn on or off items like lights. As long as the electrical capacity of the system is sufficient, the lighting zones can run at the same time as watering zones regardless of the water pressure.

In the BaseStation 3200 you can set up the concurrent zones on a per program basis and have it automatically managed using a flow device. You can also set the total number of concurrent zones for the controller.

You manage the number of zones that can run concurrently at the following levels:

- **Mainline Flow Level** – When you set up the design flow for the mainline and then set the Managed by Flow field to YES, the system uses the mainline design flow to determine how many zones can run concurrently up to the program limits. Refer to Setting Up a Mainline on page 78.
- **Program Level** – If you want a program to water more than one zone at a time, you must configure the Concurrent Zone settings at the program level.

Even if your system does not have a flow device, you can still use the Concurrent Zone settings at the program level without having to input design flows for all zones and the mainline.

When you have one or more flow devices, a good strategy is to set the program concurrency limits to a reasonable maximum and then decrease specific programs that have some special considerations (such as, the mainline branch is smaller, longer, or you want to slow the completion time of a program, or if the two-wire length is very long and you want to control the voltage drop by limiting the current to those valves).

1. Turn the dial to the **Programs** position.
2. Press the **Next** button to select the **Concurrent Zones Setup** option. The Concurrent Zones screen displays.
3. In the **Program** column, press the + or – button to select the program that you want to set up concurrent zones for.
4. Press the **Next** button to move to the **Concurrent Zones** column, and then press the + or – button to change the value in the field.

Note: The maximum number of concurrent zones per program is 15 due to the electrical capacity of the controller's transformer.

5. If you want to change the number of concurrent zones for another program, press the **Previous** button to move to the left column and repeat steps 3 and 4.

Concurrent Zones		Programs	
Program		Concurrent Zones	
-		-	
-		-	
1		1	
2		1	
3		1	
4		1	
Total Allowed		1	
		Help	

6. Press the **Next** button to move to the **Total Allowed** field, and then press the + or – button to change the value in the field. This field indicates the maximum number of concurrent zones that can run on the controller at any one time.

Note: While you can enter a number between 1 and 99 in the Total Allowed field, it is important to consider electrical and hydraulic constraints when you are setting up concurrent zones. The BaseStation 3200 transformer is capable of operating 15 concurrent zones. However, if a BaseStation 3200 is operating in conjunction with a SubStation, the transformer capacity is increased by 15 zones for each additional SubStation up to the maximum of 99 concurrent zones.

7. When you have finished making changes, turn the dial to the **RUN** position.

To enable/disable a program

You can disable a program to prevent it from running. When you want it to run again, you can enable it and still have all the settings.

1. Turn the dial to the **Programs** position.
2. Press the **Next** button to select the **Advanced Programs Setup** option. The Advanced screen displays.
3. In the **Program** field, press the + or – button to select the program that you want to enable or disable.

Advanced	Programs
Program	<input type="text" value="1"/>
{Program 1}	
Enabled	<input type="text" value="YES"/>
Priority (1=highest)	<input type="text" value="5"/>
Ignore Global Settings	<input type="text" value="NO"/>
Ignore Concurrent Zones	<input type="text" value="NO"/>
<input type="button" value="Help"/>	

4. Press the **Next** button to move to the **Enabled** field. When **YES** displays in the field, the program is enabled. If you want to disable the program, press the + or – button so **NO** displays in the field.

Note: For information about the other fields on this screen, refer to the topics about setting priority for a program on page 56, having a program ignore global settings page 57, and having a program ignore concurrent zone settings on page 58.

5. After you have configured the settings for the current program, perform one of the following options:
 - To configure another program, press the **Previous** button to return to the **Program** field. Press the **Enter** button until the number of the program that you want to configure displays in the **Program** field at the top of the screen. Repeat step 4.
 - When you have finished making changes, turn the dial to the **RUN** position.

To set the priority for a program

Each program can be given a watering priority (1 – 99, where 1 is the highest priority). When start events are hit, the program with the highest priority gets first call on the water and time. A higher priority program will preempt lower priority programs and will run to completion before the lower ones. If all programs are set to the same priority number, they run in order of the program number. Programs that have the same priority are grouped together and run at the same time as long as they are not blocked by some other condition such as concurrent zone limits or water windows.

1. Turn the dial to the **Programs** position.

2. Press the **Next** button to select the **Advanced Programs Setup** option. The Advanced screen displays.

3. In the **Program** field, press the + or – button to select the program that you want to set the priority for.

4. Press the **Next** button to move to the **Priority** field, and then press the + button to enter a number (1 – 99, where 1 is the highest priority).

Advanced	Programs
Program	<input type="text" value="1"/>
{Program 1}	
Enabled	<input type="text" value="YES"/>
Priority (1=highest)	<input type="text" value="5"/>
Ignore Global Settings	<input type="text" value="NO"/>
Ignore Concurrent Zones	<input type="text" value="NO"/>
<input type="button" value="Help"/>	

Note: For information about the other fields on this screen, refer to the topics about enabling/disabling a program on page 56, having a program ignore global settings on page 57, and having a program ignore concurrent zone settings on page 58.

5. After you have configured the settings for the current program, perform one of the following options:
 - To configure another program, press the **Previous** button to return to the **Program** field. Press the **Enter** button until the number of the program that you want to configure displays in the **Program** field at the top of the screen. Repeat step 4.
 - When you have finished making changes, turn the dial to the **RUN** position.

To have a program ignore global settings

If a program is used to operate lights or fill a fountain, you can select the Ignore Global Settings option to have the program ignore global controller settings such as a rain delay. This way, the program continues to run even when the controller is in rain delay mode.

1. Turn the dial to the **Programs** position.
2. Press the **Next** button to select the **Advanced Programs Setup** option. The Advanced screen displays.

3. In the **Program** field, press the + or – button to select the program that you want to change the setting for.

4. Press the **Next** button to move to the **Ignore Global Settings** field.

5. Press the + or – button so **YES** displays in the field.

6. After you have configured the settings for the current program, perform one of the following options:

Advanced	Programs
Program	<input type="text" value="1"/>
{10 oclock program}	
Enabled	<input type="text" value="YES"/>
Priority (1=highest)	<input type="text" value="2"/>
Ignore Global Settings	<input type="text" value="YES"/>
Ignore Concurrent Zones	<input type="text" value="NO"/>
<input type="button" value="Help"/>	

- To configure another program, press the **Previous** button to return to the **Program** field. Press the **Enter** button until the number of the program that you want to configure displays in the **Program** field at the top of the screen. Repeat steps 4 and 5.
- When you have finished making changes, turn the dial to the **RUN** position.

To have a program ignore concurrent zone settings

If a program is used to operate lights or fill a fountain, you can select this option to have the program ignore the concurrent zone settings. This way, the program continues to run even when the maximum number of valves are also operating at the same time.

Note: If you take advantage of this feature, remember that the total number of running zones must stay within the electrical limits of the system.

1. Turn the dial to the **Programs** position.
2. Press the **Next** button to select the **Advanced Programs Setup** option. The Advanced screen displays.
3. In the **Program** field, press the + or – button to select the program that you want to change the setting for.

Advanced	Programs
Program {10 o'clock program}	<input type="text" value="1"/>
Enabled	<input type="text" value="YES"/>
Priority (1=highest)	<input type="text" value="2"/>
Ignore Global Settings	<input type="text" value="NO"/>
Ignore Concurrent Zones	<input checked="" type="text" value="YES"/>
<input type="text" value="Help"/>	

4. Press the **Next** button to move to the **Ignore Concurrent Zones** field.
5. Press the + or – button so **YES** displays in the field.
6. After you have configured the settings for the current program, perform one of the following options:

- To configure another program, press the **Previous** button to return to the **Program** field. Press the **Enter** button until the number of the program that you want to configure displays in the **Program** field at the top of the screen. Repeat steps 4 and 5.
- When you have finished making changes, turn the dial to the **RUN** position.

To adjust programs for seasonal variations

In order to provide a full range of functionality, the BaseStation 3200 controller firmware includes an option to increase or decrease the amount of time all zones in a program will water. However, we recommend that you use other methods for adjusting the amount of water that your irrigation system is putting down. A healthier way to water turf is to always water deep (about the same amount of time) and change the frequency of watering to maintain the correct moisture level. Use the Day Intervals schedule for better results. Refer to Setting up the day intervals for a program on page 50.

1. Turn the dial to the **Smart Watering** position.
2. Press the **Next** or **Previous** button to select **Program Seasonal Adjust**, and then press the **Enter** button. The Season Adjust screen displays and shows all programs set to 100%.
3. Press the **+** button to move to the program where you want to adjust the percentage.
4. Press the **Next** button to move to the **Adjust %** column.
5. Press the **+** or **-** button to change the percentage. You can set the percentage between 10 and 500%.
6. After you have configured the settings for the current program, perform one of the following options:
 - To configure another program, press the **Enter** button until the number of the program that you want to configure displays in the **Program** field at the top of the screen. Repeat steps 4 and 5.
 - When you have finished making changes, turn the dial to the **RUN** position.

Season Adjust		Smart Watering	
Program		Adjust %	
98		100%	
99		100%	
1		100%	
2		100%	
3		100%	
4		100%	
5		100%	

Program: {Program 1}

Help

Associating Zones with a Program

In your landscape, you probably have zones that need to be watered every day (such as those that water annuals in full sun) and other zones that need to be watered less frequently (such as shrub borders). You might also have programs that operate lights or lock and unlock doors.

In order to manage these different operating schedules, it is best to create separate programs for the annuals, the shrubs, the lights, and the door locks, and then associate the specific zones with the appropriate program.

Prerequisites

- The devices have been correctly assigned in the controller.
- You know the numbers of the zones that water the specific landscape areas or operate the relays for the lights or door locks.
- Zones that are to be used for watering have been assigned to their appropriate mainline.

Programming Instructions

1. Turn the dial to the **Zones** position. The Zones screen displays.

- In the **Zone** field, press the + or – button to select the number of the zone that you want to associate with a program.
- Press the **Previous** button to go to the **Program** field.
- Press the + or – button to select the program that you want the zone to be associated with.
- Complete the other zone fields according to the instructions in Configuring Zone Settings on page 37.

Zones	
{Shrub Beds}	Zone [VA00005] 1
2	{North Park MP's}
Program	Zone Mode Primary
	Water Time (h:mm) 1:00
	Cycle Time (h:mm) 0:20
	Soak Time (h:mm) 0:40
	Enabled YES
	Use ET Deficit Water Times NO
Programs: 1,2	Help

Note: Zones can be associated with multiple programs. Whenever a zone has a water time set in a program, the zone is associated with the program. The programs that the zone is associated with are shown in the lower-left corner of the screen.

- Repeat steps 2 – 5 to associate all zones with a specific program.
- When you have finished making changes, turn the dial to the **RUN** position.

Removing a Zone from a Program

Zones can be associated with multiple programs. Whenever a zone has a water time set in a program, the zone is associated with the program. The programs that the zone is associated with are shown in the lower-left corner of the screen.

- Turn the dial to the **Zones** position. The Zones screen displays.
- In the **Zone** field, press the + or – button to select the number of the zone that you want to remove from a program.
- Press the **Previous** button to go to the **Program** field.
- Press the + or – button to select the program that you want the zone to be removed from.
- Press the **Next** button to move to the **Water Time** field.
- When the hours placeholder is highlighted, press the – button to remove the time from the **Water Time** field.
- When you have finished making changes, turn the dial to the **RUN** position.

Zones	
{Turf Sprays North}	Zone [VA00006] 6
1	{ZN 6}
Program	Zone Mode -
	Water Time (h:mm) -:-
	Cycle Time (h:mm) -:-
	Soak Time (h:mm) -:-
	Enabled YES
	Use ET Deficit Water Times YES
Programs: 2,3	Help

Setting Up Soil Moisture Sensor Based Watering

You can take the guesswork out of your watering decisions by setting up soil moisture sensor based watering. The biSensor measures soil moisture where the plants need it – at the root level.

When you have a biSensor installed, the BaseStation 3200 enables you to set up one of the following water strategies:

- **Timed** – Waters without biSensor control, but provides a log of daily moisture levels.
Note: Be sure to use the Timed water strategy with new grass. After the root zone is established, you can change to one of the other strategies.
- **Lower Limit** – Prevents watering until the moisture level drops below the limit, and then a full water cycle will run. The user sets and manages the limit and the water time. The lower limit watering strategy tells the controller to start watering based on the start time and the moisture reading and stop watering the runtime is complete.
- **Upper Limit** – Allows watering at each start time, but the water time is adjusted to replenish the moisture to field capacity. The user sets and manages the limit and the base water time. Ensure that ½ inch or more of water is applied frequently enough to water sufficiently during the hottest period of the season. With upper limit, you can choose which day and what time of day to start watering and the sensor will shut off watering when soil moisture reaches the upper limit.

Make sure that you have soak cycles properly set up for the zones that will be using soil moisture based watering. In addition to allowing the applied water to soak into the soil, soak cycles allow time for the water to reach the biSensor depth so the soil moisture readings are accurate. Refer to Using Soak Cycles on page 46.

Prerequisites

- Your biSensors are installed and assigned in the BaseStation 3200. Make sure to assign the correct biSensor to its primary zone in the correct program. Making an incorrect assignment here will result in unexpected and confusing water behavior. Refer to Searching For and Assigning Devices on page 35.
- You have created scheduling groups (a primary zone with linked zones) that combine areas with similar watering needs (hydrozones). For example, the zones that water the softball field would be in one scheduling group and the zones that water the north lawn between the sidewalk and the building would be in another scheduling group. Refer to Linking Zones (Creating a Scheduling Group) on page 45.

Assigning biSensor Soil Moisture Sensors to Primary Zones

If you want to use soil moisture sensors (biSensors) to monitor your zones, you need to assign a biSensor to a primary zone. If you have not configured any primary zones, you will not be able to complete the following procedure. Refer to Setting Up a Primary Zone on page 44.

Keep in mind that a zone can be a primary zone in more than one program. When you are assigning a biSensor, make sure to select the correct zone and program.

Note: The BaseStation 3200 supports 25 biSensors.

1. If you have not searched for and assigned the biSensor to an address in the controller, do that first. Refer to Searching for and Assigning Devices on page 35.
2. Turn the dial to the **Smart Watering** position.
3. The **Moisture biSensor Assignments** option should be highlighted. If it is not highlighted, press the + or – button to select it.
4. Press the **Enter** button. The Assign biSensor screen displays.
5. Press the + or – button to select the number of the biSensor that you want to assign, and then press the **Enter** button. The number moves from the list on the left to zone address/program list on the right.
6. When you have finished making changes, turn the dial to the **RUN** position.

Assign biSensor		Smart Watering		
biSensors [minus plus]		Assign Zone/Prg to biSensor		
		Zone	Prg	biSensor
Help		-	-	-
Unassign		-	-	-
MS 1	Enter to	1	1	MS 1
-	----->	-	-	-
-	Assign	-	-	-
-		-	-	-
biSensor: {Moisture biSensor 1/5B08685}				
Zone: {Zone 1}				

Unassigning a biSensor Soil Moisture Sensor

You can remove a moisture sensor from its zone and program assignment.

Note: You can also change how biSensors are assigned to addresses in the controller. For more information about this procedure, refer to Changing Device Assignments on page 40.

1. Turn the dial to the **Smart Watering** position.
2. The **Moisture biSensor Assignments** option should be highlighted. If it is not highlighted, press the + or – button to select it.
3. Press the **Enter** button. The Assign biSensor screen displays.
4. Press the **Next** button to move to the Assign Zone/Prg to biSensor grid.
5. Press the **Next** or **Previous** button to select the row for the biSensor that you want to unassign.
6. Press the + or – button to move to the biSensor list and select **Unassign**.
7. Press the **Enter** button. The moisture sensor is removed from the zone/program assignment.

Assign biSensor		Smart Watering		
biSensors [minus plus]		Assign Zone/Prg to biSensor		
		Zone	Prg	biSensor
-		-	-	-
Help		1	1	MS 1
Unassign	Enter to	1	4	MS 1
MS 1	<-----	-	-	-
-	Clear	-	-	-
-		-	-	-
biSensor:				
Zone: {Zone 1}				

Note: When you unassign a biSensor, the zone will no longer operate using a soil moisture sensor based watering strategy. Go to the zone settings in the program and make sure they are correct for ongoing watering. Refer to Configuring Zone Settings on page 37.

Configuring the biSensor Settings

1. Turn the dial to the **Smart Watering** position.
2. Press the **Next** button to select **Moisture biSensor Setup**, and then press the **Enter** button. The biSensor Setup screen displays.

biSensor Setup	Smart Watering
Primary Zone/Prog	ZN 1 / PG 1
Water Strategy	Lower Limit
Lower Limit (turn on)	26.0%
Limit Adjustment	0.0 %
Calibration Cycle	One Time
biSensor: {Moisture biSensor 1/5B08685}	
Zone: {Zone 1}	
Help	

3. If you have more than one biSensor installed and assigned to a primary zone in more than one program, verify that the correct primary zone and program displays in the **Primary Zone/Prg** field (the serial number of the assigned biSensor displays below the field). If the biSensor that you want to configure is not displayed below the field, press the + or – button to select the correct primary zone and program.
4. Press the **Next** button to move to the **Water Strategy** field, and then press the + or – button to select the water strategy that you want to use.

IMPORTANT NOTE! If you select the Upper or Lower Limit strategies, be sure to read the information below for a complete explanation of these strategies.

5. Press the **Next** button to move to the **Upper/Lower Limit** field (the field that displays depends on the water strategy that you selected). Press the + or – button to change the number in the field.
 6. Press the **Next** button to move to the **Limit Adjustment** field.
- Note:** This field is typically used to offset the limit set by a calibration cycle. If you think that you might need to use this field, contact Baseline Support for help.
7. Press the **Next** button to move to the **Calibration Cycle** field.

- **Never** – No calibration cycle will be performed
- **One Time** – A single calibration cycle will be performed at the next start time
- **Monthly** – A calibration cycle will be performed each month at the first start time

Note: Calibration cycles require that soak cycles be enabled. When you set these watering strategies, soak cycles will be automatically enabled. You may change the settings to meet your specific needs, but if you disable the soak cycles, the calibration cycle will fail.

8. When you have finished making changes, turn the dial to the **RUN** position.

Note: If for any reason the biSensor becomes damaged or fails (12 hours of failed data or communication) the corresponding primary zone and linked zones will water based on a timed operating mode which is based on set water times and program schedule.

Understanding Lower & Upper Limit Watering Strategies

Lower Limit

This water strategy provides an excellent way to achieve healthy, deep-rooted grass. You can either set the lower limit manually or you can have the controller perform a calibration cycle in order to calculate the limit. Set the lower limit at the maximum allowable depletion moisture level, just before the lawn begins to stress or wilt.

When you choose the lower limit watering strategy, you must set and then manage the lower watering limit. This watering strategy works well when you are not constrained by specific water days. Schedule the program to water every day, and then let the biSensor determine which days to skip by monitoring the moisture level. The controller only waters when the moisture level has dropped below the lower limit, and then a full watering cycle runs.

The best way to set the lower limit is to have the controller do an initial calibration cycle. Set the Calibrate field to One Time. The calibration cycle will run during the first normally scheduled water time that is at least 2 days after the biSensor installation. The system sets an initial lower limit based on the calibration.

You have the option to adjust the auto limit by entering a value in the Limit Adjustment field. This adjustment is added to the limit to make the soil a little wetter or a little drier than the controller set limit.

Lower Limit Programming Requirements

- Set zone runtimes to apply ½ - ¾ inch of water
- Set program to start every day of the week as allowed by local watering restrictions (the biSensor will block watering until it is needed)
- Enable soak cycles
- Use the default lower limit water strategy to begin with
 - The first calibration cycle occurs on the first start time after a biSensor has been installed for at least 48 hours.
 - A calibration cycle will calculate limits 12 to 15 hours after watering is complete on the primary zone.
 - A calibration cycle will extend the programmed zone water time if needed to determine the soil saturation point - if the ground is very dry (or if the water time is too short), the water time could extend to twice the programmed time.
 - If a calibration cycle cannot determine the soil saturation point, the calibration cycle will fail – posting an alert and setting a default limit.

Lower Limit Watering Behaviors

- It is uncertain which days of the week when watering will occur – use water windows or block a day to specify a mow day.
- The runtime for a zone is fixed, so the end time is predictable to the extent that multiple programs may all be trying to water on the same day.

Upper Limit

This watering strategy varies the zone's runtime each time the program runs in order to apply enough water to raise the moisture level to field capacity. Soak cycles are critical for this mode because the controller monitors the moisture level as water is applied. At the end of each soak cycle, the controller determines whether an additional water cycle is needed. After the upper limit has been reached, the controller will water for an additional 10% of the runtime to increase deep watering.

When you choose the upper limit watering strategy, you must set and manage the upper watering limit. You can have the controller perform an initial calibration cycle to establish the starting limit value. This calibration cycle will be run on the first start time, 2 days after the biSensor installation date. After the initial calibration cycle has been run, you must monitor the moisture levels and plant health so you can make adjustments as needed.

Upper limit watering starts a watering cycle on each start time for the primary zone and adjusts the zone's runtime to raise the moisture level back up to the upper limit (field capacity). The controller increases or decreases the runtime, but it never adjusts more than twice your initial runtime.

Upper Limit Programming Requirements

- Set the zone runtime to apply $\frac{1}{2}$ inch to $\frac{3}{4}$ inch of water
- Set the program to use Historical Calendar day intervals (or alternately, specific days of the week or fixed intervals)
- Enable soak cycles

Upper Limit Watering Behaviors

- The water schedule is known as far as what days watering will occur – use water windows to specify a mow day.
- The runtime for the zones in a program is variable, so the program's end time is not predictable – if there are completion time constraints, this may not be a good water strategy.

Complying with Water Restrictions

There are times and seasons when water restrictions are placed on areas. Keeping a green and healthy landscape during these restrictions is best achieved with deep rooted turf! Train your grass before the crisis to grow deep roots by watering deeply and only when the grass needs it.

Note: If you are in an area that is under severe water restrictions, do not try to water using biSensors – set the water strategies to Timed and apply permitted water. You can use the moisture graphs to track the moisture depletion rate.

The first step in understanding how to keep the controller from watering when it should not is to identify under what conditions it will allow watering. The BaseStation 3200 controller will start a program when all of the following conditions have been met:

- Program start time
- Valid water day
- If the lower limit watering strategy is used with a moisture biSensor, then the moisture level at the program start time is less than the limit
- There isn't a scheduled event date
- There isn't a rain sensor stop condition
- There isn't another controller stop condition (such as a high flow shutdown)

The program will run to completion, spanning days if needed. The running program may be paused for some period of time by one of the following conditions, after which it will resume until it has completed:

- Closed water window (white square)
- Pause switch or pause biCoder
- Turning the dial to make a programming change – when the dial is left in a programming position, the controller will return to run mode in 2 hours just as if the dial had been turned back to Auto/Run.

If there are specific days that cannot be used for watering, use one of the following methods to meet those requirements:

- Start programs after midnight and provide enough time for them to complete during a single day so they do not span into the next day.
- Use water windows to block out specific days.

Setting Up Start, Stop, and Pause Conditions

The BaseStation 3200 enables you to set up conditions based on the status of devices that will start, stop, or pause specific programs and stop or pause the entire controller. You can use the following devices to monitor these conditions:

- **Event biCoder** – Set up a switch, such as a coach’s button, to start, stop, or pause watering for a program. You can also configure the switch to stop or pause watering for the entire controller.
- **Soil Moisture biSensor** – Set up a soil moisture sensor to start, stop, or pause watering based on a specific reading. You can also configure the soil moisture sensor to stop or pause watering for the entire controller.
- **Air Temperature biSensor** – Set up an air temperature sensor to start, stop, or pause watering based on a specific reading. You can also configure the air temperature sensor to stop or pause watering for the entire controller.
- **Pressure Sensor** – Set up a pressure sensor to start, stop, or pause watering based on a specific reading. You can also configure the pressure sensor to stop or pause watering for the entire controller.

To set up a start condition for a program

1. If you have not searched for and assigned the start device to an address in the controller, do that first. Refer to Searching for and Assigning Devices on page 35.
2. Turn the dial to the **Start, Stop, Pause** position.
3. Press the **Next** or **Previous** button to select the **Device Start Conditions** option.
4. Press the **Enter** button. The Device Start screen displays, and the Program column is active.

5. In the **Program** column, press the + button to select the program that you want to set up the start condition for.
6. Press the **Next** button to move to the **Devices** column. The event switches, moisture sensors, temperature sensors, and pressure sensors assigned in the controller display in the Devices column. The devices are labeled with the following abbreviations:

- EV for event switch
- MS for moisture sensor
- TS for temperature sensor
- PR for pressure sensor

7. Find the abbreviation and number of the device that you want to use for the start condition in the **Devices** column. Press the + button to select the device, and then press the **Enter** button.

Note: When you assign a device on one of the Start, Stop, and Pause Condition screens in the BaseStation 3200, that device is available in the Devices column on each of these screens.

Device Start		Start, Stop, Pause
		Currently Closed
Pgm	Devices	1 of 8
99	-	-
-	-	-
1	EV 1	Y
2	EV 2	
3	EV 3	
4	EV 4	
{Turf Sprays North}		
{Event biCoder RP00359}		
		Limit
		Open
		Trigger
		Equals
		Help

Because the devices are available on multiple screens, you can use one device to handle more than one condition. You can also search and assign a start/stop/pause device on any of these screens regardless of the condition the device will handle. While the controller allows you to enable up to 8 devices for start conditions on a single program, it is best to use just one device per program.

8. Press the **Next** button to move to the **Limit** field. Press the **+** button to choose the setting based on the type of device you are configuring:
 - **Event Switch** – The setting can be Open or Closed.
 - **Moisture Sensor** – The setting is a moisture percentage.
 - **Temperature Sensor** – The setting is a temperature in degrees Fahrenheit.
 - **Pressure Sensor** – The setting is an amount in psi (pounds per square inch).
9. Press the **Next** button to move to the **Trigger** field. Press the **+** button to choose the setting based on the type of device you are configuring:
 - **Event Switch** – The setting can be Equals or Off.
 - **Moisture Sensor** – The setting can be Above, Below, or Off.
 - **Temperature Sensor** – The setting can be Above, Below, or Off.
 - **Pressure Sensor** – The setting can be Above, Below, or Off.
10. When you have finished making changes, turn the dial to the **RUN** position.

When the configured device detects the start condition and no other inhibitors are present, such as a closed water window, flow limit settings, or a rain delay, the program will start.

This start condition is associated with a program, which, in turn, might have one or more start times set. If you don't want the program to start based on the time as well as the condition, be sure to remove the start time from the program. Refer to Setting Up Programs on page 48.

To set up a pause condition for a program or for the entire controller

Note: If you have a program that operates locks or lights, you can set it to run even when a controller-wide pause condition is active. Refer to the topic about having a program ignore global settings on page 57.

1. If you have not searched for and assigned the pause device to an address in the controller, do that first. Refer to Searching for and Assigning Devices on page 35.
2. Turn the dial to the **Start, Stop, Pause** position.
3. Press the **Next** or **Previous** button to select the **Device Pause Conditions** option.
4. Press the **Enter** button. The Device Pause screen displays, and the Program column is active.

5. In the **Program** column, perform one of the following options:

- To set up a pause condition that applies to the entire controller, select **All** in the **Program** column.
- To set up a pause condition that applies to a specific program, press the + button to select the program number in the **Program** column.

Device Pause		Start, Stop, Pause	
			Currently 93.1F
Pgm	Devices	1 of 8	Limit
All	EV 3		65.0F
1	EV 4		Trigger
2	TS 1	Y	Above
3	-	-	Pause Time
4	-	-	1:00
5	-	-	
{Shrub Beds}			
{Temperature biSensor AT01130}			
			Help

6. Press the **Next** button to move to the **Devices** column. The event switches,

moisture sensors, temperature sensors, and pressure sensors assigned in the controller display in the Devices column. The devices are labeled with the following abbreviations:

- EV for event switch
- MS for moisture sensor
- TS for temperature sensor
- PR for pressure sensor

7. Find the abbreviation and number of the device that you want to use for the pause condition in the **Devices** column. Press the + button to select the device, and then press the **Enter** button.

Note: When you assign a device on one of the Start, Stop, and Pause Condition screens in the BaseStation 3200, that device is available in the Devices column on each of these screens. Because the devices are available on multiple screens, you can use one device to handle more than one condition. You can also search and assign a start/stop/pause device on any of these screens regardless of the condition the device will handle. You can assign up to 8 devices.

8. Press the **Next** button to move to the **Limit** field. Press the + button to choose the setting based on the type of device you are configuring:

- **Event Switch** – The setting can be Open or Closed.
- **Moisture Sensor** – The setting is a moisture percentage.
- **Temperature Sensor** – The setting is a temperature in degrees Fahrenheit.
- **Pressure Sensor** – The setting is an amount in psi (pounds per square inch).

9. Press the **Next** button to move to the **Trigger** field. Press the + button to choose the setting based on the type of device you are configuring:

- **Event Switch** – The setting can be Equals or Off.
- **Moisture Sensor** – The setting can be Above, Below, or Off.
- **Temperature Sensor** – The setting can be Above, Below, or Off.
- **Pressure Sensor** – The setting can be Above, Below, or Off.

10. Press the **Next** button to move to the **Pause Time** field. Press the + button to set the amount of time for the pause in hours. The allowable range is from 1 to 72 hours.

11. When you have finished making changes, turn the dial to the **RUN** position.

When the configured device detects the pause condition, it will pause either the program or the entire controller (if it was set up for All). All watering zones will be put into a soaking state and no new zones will be started while the pause is in effect. If a program starts when a pause condition is in effect, the program will be put into a pause state after the first minute. When the pause time expires, programs will resume from where they were when the pause went into effect.

When a pause condition is in effect, the controller displays a message. If a user clears that message, the pause condition will also be cleared.

To set up a stop condition for a program or for the entire controller

Note: If you have a program that operates locks or lights, you can set it to run even when a controller-wide stop condition is active. Refer to the topic about having a program ignore global settings on page 57.

1. If you have not searched for and assigned the stop device to an address in the controller, do that first. Refer to Searching for and Assigning Devices on page 35.
2. Turn the dial to the **Start, Stop, Pause** position.
3. Press the **Next** or **Previous** button to select the **Device Stop Conditions** option.

4. Press the **Enter** button. The Device Stop screen displays, and the Program column is active.

5. In the **Program** column, perform one of the following options:

- To set up a stop condition that applies to the entire controller, select **All** in the **Program** column.
- To set up a stop condition that applies to a specific program, press the + button to select the program number in the **Program** column.

Device Stop			Start, Stop, Pause
			Currently 93.1 F
Pgm	Devices	1 of 8	Limit
1	EV 3		65.0 F
2	EV 4		Trigger
3	TS 1	Y	Above
4	-	-	
5	-	-	
6	-	-	
{Overseed}			
{Temperature biSensor AT01130}			
			Help

6. Press the **Next** button to move to the **Devices** column. The event switches, moisture sensors, and temperature sensors assigned in the controller display in the Devices column. The devices are labeled with the following abbreviations:

- EV for event switch
- MS for moisture sensor
- TS for temperature sensor
- PR for pressure sensor

7. Find the abbreviation and number of the device that you want to use for the stop condition in the **Devices** column. Press the + button to select the device, and then press the **Enter** button.

Note: When you assign a device on one of the Start, Stop, and Pause Condition screens in the BaseStation 3200, that device is available in the Devices column on each of these screens. Because the devices are available on multiple screens, you can use one device to handle more than one condition. You can also search and assign a start/stop/pause device on any of these screens regardless of the condition the device will handle. You can assign up to 8 devices.

8. Press the **Next** button to move to the **Limit** field. Press the + button to choose the setting based on the type of device you are configuring:
 - **Event Switch** – The setting can be Open or Closed.
 - **Moisture Sensor** – The setting is a moisture percentage.
 - **Temperature Sensor** – The setting is a temperature in degrees Fahrenheit.
 - **Pressure Sensor** – The setting is an amount in psi (pounds per square inch).
9. Press the **Next** button to move to the **Trigger** field. Press the + button to choose the setting based on the type of device you are configuring:
 - **Event Switch** – The setting can be Equals or Off.
 - **Moisture Sensor** – The setting can be Above, Below, or Off.
 - **Temperature Sensor** – The setting can be Above, Below, or Off.
 - **Pressure Sensor** – The setting can be Above, Below, or Off.
10. When you have finished making changes, turn the dial to the **RUN** position.

When the configured device detects the stop condition, it will stop either the program or the entire controller (if it was set up for All).

Setting Up Event Dates

The BaseStation 3200 supports 8 event dates. An event date stops watering and keeps programs from starting on that date. You can set up an event date for a specific program or for the entire controller. You can schedule an event date up to a year in advance.

Note: If you have a program that operates locks or lights, you can set it to run even when a controller-wide event date is scheduled. Refer to the topic about having a program ignore global settings on page 57.

An event date is from 12:00am – 11:59pm.

1. Turn the dial to the **Start, Stop, Pause** position.
2. Press the **Next** button to select the **Event Dates** option.
3. Press the **Enter** button. The Event Date/Time screen displays.
4. In the **Program** column, perform one of the following options:
 - To set up an event date that applies to the entire controller, select **All** in the **Program** column.
 - To set up an event date that applies to a specific program, press the + button to select the program number in the **Program** column.
5. Press the **Next** button to move to the **Stop Watering Date** column.

Event Date/Time	Start, Stop, Pause
Pgm	Stop Watering Date
99	1 12/16/17
All	2 -
1	3 -
2	4 -
3	5 -
4	6 -
{Turf Sprays North}	7 -
	8 -

Help

6. Press the **+** button to set the desired date.
7. If you want to set up another event date, press the **Enter** button to move to the next line, and then repeat step 6.
8. If you want to set up an event date for another program, press the **Previous** button to return to the **Program** column, and then press the **+** button to select the program that you want to set up event dates for.
9. Repeat steps 5 and 6 to set up the date.
10. When you have finished making changes, turn the dial to the **RUN** position.

Setting Up Rain Delay Days

You can delay watering for up to 180 days with the Rain Delay setting. A rain delay stops all watering and prevents all programs from starting for the set number of days starting on the current day.

The rain delay begins as soon as the command is submitted and ends at 11:59pm on the last scheduled day.

Note: If you have a program that operates locks or lights, you can set it to run even when a rain delay is active. Refer to the topic about having a program ignore global settings on page 57.

1. Turn the dial to the **Start, Stop, Pause** position.
2. Press the **Next** button to select the **Rain Delay Days** option.
3. Press the **Enter** button. The Start, Stop, Pause screen displays.
4. In the **Rain Delay Days** field, press the **+** button to set the number of days for the delay.

Note: Press and hold the **+** button or the **-** button to rapidly increase or decrease the number in the field.

5. When you have finished making changes, turn the dial to the **RUN** position.

At the end of the scheduled rain delay, the controller will begin running normally. If you need to cancel a rain delay before it is scheduled to end, return to the rain delay screen and change the setting in the field to 0 (zero).

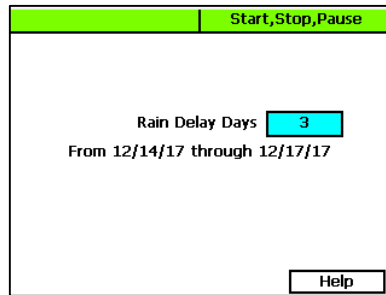

7 – Flow Management & Monitoring

The BaseStation 3200 provides an extensive set of flow management and monitoring capabilities to help identify where water is coming from, to understand how water is being used, and to reduce the effects of pipeline breaks and sprinkler malfunctions. It can monitor actual water flow rates and compare them against the expected or design flow rates. It can generate alerts and perform actions when limits or boundaries are exceeded. The system can reduce the overall completion time of a watering cycle by running the number of zones that best use the available water at each minute of the watering cycle.

Using a flow device to monitor water flow rates and water used is the best way to manage this precious resource, but even without a flow device, the BaseStation 3200 has many capabilities that can improve the efficiency of your system.

The BaseStation 3200 has the following flow components that enable you to model your hydraulic system within the controller.

- Water source (WS)
- Control Point (CP)
- Mainline (ML)

From the factory, the controller has water source 1 (WS1) enabled and assigned to control point 1 (CP1). CP1 is enabled and assigned to mainline 1 (ML1). No other water sources are assigned or enabled. On the controller, this default configuration is represented as:

[WS1] → [CP1] → [ML1]

Before you begin setting up the flow components and building your hydraulic system model in the BaseStation 3200, make sure you understand the terminology and the requirements:

Water Source

- A water source identifies where water is coming from.
- A BaseStation 3200 supports up to 8 water sources.
- Each water source can be connected to a single control point.
- If you have a FlowStation, you can designate how a water source is managed:
 - A “local” water source is managed by the BaseStation 3200 irrigation controller.
 - A “shared” water source is managed by the FlowStation.

Control Point

- A control point is a hydraulic component in Baseline controllers that collects data from assigned devices, and then enables the irrigation system to act on that data.
- A BaseStation 3200 supports up to 8 control points.
- Each control point can have a:
 - Flow sensor/meter with an appropriate k-value to read and record both the flow usage and rate.
 - Pump that can be used to control the flow of water through the control point.
 - The main difference between a pump and a master valve is that a master valve supplies 24VAC to a solenoid to open a valve and a pump uses a pump start relay to start a pump.
 - The master valve will report open or shorted solenoids where the pump will not.
 - Master valve (either normally open or normally closed) that can be used to control the flow of water through the control point.
 - Pressure sensor with appropriate 4-20 mA range to read and record the pressure at the control point.
- A control point can be connected to a water source. On the FlowStation, you can also create a “mainline in” and a “mainline out” connection for a single control point.
- If you have a FlowStation, you can designate how a control point is managed:
 - A “local” control point is managed by the BaseStation 3200 irrigation controller.
 - A “shared” control point is managed by the FlowStation.

Mainline

- The mainline is the section of pressurized pipe from the control point to the valve that operates water flow to a zone.
- A BaseStation 3200 supports up to 8 mainlines.
- On the FlowStation, you can create a “mainline to mainline” connection, which enables you to represent a small mainline branching off a larger mainline.
- A zone is assigned to a mainline.
- If you have a FlowStation, you can designate how a mainline is managed:
 - A “local” mainline is managed by the BaseStation 3200 irrigation controller.
 - A “shared” mainline is managed by the FlowStation.

Setting Up the Flow Components

To get the most out of the flow management features in your BaseStation 3200 controller, Baseline recommends that you set up the properties of the flow components in the controller to match their corresponding components in the hydraulic system at your site.

Setting Up a Water Source

The BaseStation 3200 supports 8 separate water sources. From the factory, the controller has water source 1 (WS1) enabled and connected to control point 1 (CP1). CP1 is enabled and connected to mainline 1 (ML1). No other water sources are connected or enabled.

1. Turn the dial to the **Water Sources** position.
2. If the **Water Sources Setup** option is not highlighted, press the **Next** or **Previous** button to select it.
3. Press the **Enter** button. The WS Settings screen displays.
4. In the **Water Source** field, press the + or – button to designate a number for the water source that you want to set up.
5. Press the **Next** button to move to the **Use this WS** field. Press the + or – button to toggle the setting between **YES** and **NO** as needed.

WS Settings	Water Sources
Water Source {Well}	<input type="text" value="WS1"/>
Use this WS	<input type="text" value="YES"/>
Priority (1=High)	<input type="text" value="1"/>
Monthly Budget GAL	<input type="text" value="100.0"/>
Daily Water Rationing	<input type="text" value="NO"/>
	Shut Down <input type="text" value="YES"/>
[WS1] --> [CP1] --> [ML1]	
<input type="button" value="Help"/>	

6. Press the **Next** button to move to the **Priority** field. Press the + or – button to change the value in the field to a number between 1 and 10 where 1 is the highest priority. When an irrigation system has more than one water source with different priorities, water from the source with the highest priority is used first until the monthly budget limit is reached. Then the system switches to the water source with the next highest priority.
7. Press the **Next** button to move to the **Monthly Budget GAL** field. Press the + or – button to change the value in the field to show the number of gallons that can be used from this water source during a month. The value increases in increments of 250 gallons.

Note: When the value in the Monthly Budget field is greater than zero, the system monitors the total water used during a single month. If the monthly water used exceeds this number, an alert is generated. If you set the Shut Down field to YES, then the water is stopped until the first of the next month.

8. Press the **Next** button to move to the **Shut Down** field. Press the + or – button to toggle the value in the field between **YES** and **NO**. This setting indicates whether the water source will shut down when the monthly budget amount has been exceeded.
9. Press the **Next** button to move to the **Daily Water Rationing** field. Press the + or – button to toggle the value in the field between **YES** and **NO**. When you enable water rationing, the system determines the daily water ration by dividing the number of gallons in the Monthly Budget field by the number of days in the month. The system will use only the ration amount for daily watering. If a day is skipped, that water ration is available the next day.

Setting Up a Control Point

A control point is a hydraulic component in Baseline controllers that collects data from assigned devices, and then enables the irrigation system to act on that data.

Note: The step-by-step procedure for setting up the control point is on page 78.

The BaseStation 3200 supports 8 separate control points.

You can set the following values for each control point on the CP Settings screen:

- **Design Flow** – In this field, you can enter the specified gallons per minute (GPM) for the water running through the flow device to the connected mainline. The BaseStation 3200 uses this value to manage the number of concurrent zones so that the water is used as efficiently as possible. If you set this value to zero, you cannot use this GPM amount to control zone concurrency.
- **High Flow Limit** – The system uses the GPM value in this field as a critical limit. When this value is greater than zero, the system compares the limit against the measured reading from the flow device every minute. If the flow rate reading exceeds the limit for 3 or 4 minutes in a row, the system generates an alert.

If you set the Shut Down field to Y (yes), then zones (valves) assigned to this control point's mainline will be stopped and corresponding master valves (MVs) will be shut off when the flow rate exceeds the limit.

If the flow device is a Flow+NOMV (normally open master valve) type, the flow limit is programmed into the flow device. The system monitors the high flow limit and the NOMV shuts off when the flow limit is exceeded. When a flow device is connected to external power, the NOMV will shut off even when the controller off or powered down.

- **Unscheduled Flow Limit** – When this limit is set to greater than zero, the system monitors the flow 24x7 for any flow that does not correspond to running programs.

When you have a NOMV, you can set this limit to allow some flow that is off schedule, such as from manual taps or hose bibs.

If the flow exceeds the limit for several minutes, the system generates an alert. If you set the Shut Down field to Y (yes), then the associated MVs will turn off.

- **Pressure Limits** – If you have a pressure sensor and pressure biCoder associated with this control point, you can set operating limits based on pressure readings.

To set up a control point

1. Turn the dial to the **Water Sources** position.
2. Press the **Next** or **Previous** button to select the **Control Point Setup** option.
3. Press the **Enter** button. The CP Settings screen displays.

4. In the **Control Point** field, press the + or – button to designate a number for the control point that you want to set up.
5. Press the **Next** button to move to the **Use this CP** field. Press the + or – button to toggle between **YES** and **NO** as needed.
6. Press the **Next** button to move to the **Design Flow GPM** field, and then press the + or – button to enter the amount of flow in gallons per minute (GPM) that is allowed through this control point for the irrigation system.

CP Settings	Water Sources	
Control Point {Control Point 1}	CP1	
Use this CP	YES	
Design Flow GPM	20.0	Shut Down
High Flow Limit GPM	0.0	-
Unscheduled Flow GPM	0.0	-
High Pressure Limit PSI	0.00	-
Low Pressure Limit PSI	1.00	NO
[WS1] --> [CP1] --> [ML1]		
		Help

7. Press the **Next** button to move to the **High Flow Limit GPM** field, and then press the + or – button to enter the maximum amount of flow in gallons per minute.
8. Press the **Next** button to move to the **Shut Down** field. If you want zones (valves) assigned to this control point’s mainline to be stopped and corresponding MVs shut off when the flow rate exceeds the limit, press the + button to enter a **Y** (yes) in the field. If you do not want excessive flow to shut down the system, enter an **N** (no) in the field.
9. Press the **Next** button to move to the **Unscheduled Flow Limit GPM** field, and then press the + or – button to enter the maximum amount of unscheduled flow in gallons per minute.
10. Press the **Next** button to move to the **Shut Down** field. If you want the associated MVs to turn off when an unscheduled flow exceeds this limit, press the + button to enter a **Y** (yes) in the field. If you do not want excessive flow to shut down the system, enter an **N** (no) in the field.
11. Press the **Next** button to move to the **High Pressure Limit PSI** field, and then press the + or – button to enter the maximum amount of pressure in PSI.
12. Press the **Next** button to move to the **Shut Down** field. If you want the associated MVs to turn off when the pressure exceeds this limit, press the + button to enter a **Y** (yes) in the field. If you do not want excessive pressure to shut down the system, enter an **N** (no) in the field.
13. Press the **Next** button to move to the **Low Pressure Limit PSI** field, and then press the + or – button to enter the minimum amount of pressure in PSI.
14. Press the **Next** button to move to the **Shut Down** field. If you want the associated MVs to turn off when the pressure drops below this limit, press the + button to enter a **Y** (yes) in the field. If you do not want low pressure to shut down the system, enter an **N** (no) in the field.

Setting Up a Mainline

1. Turn the dial to the **Flow** position.
2. Press the **Next** button to select the **Mainline Setup** option.
3. Press the **Enter** button. The Setup Mainline screen displays.
4. In the **Mainline** field, press the + button to select the Mainline that you want to set up.
5. Press the **Next** button to move to the **Use This Mainline** field, and then press the + or – button to toggle the setting between **YES** and **NO**.
6. Press the **Next** button to move to the **Design Flow** field, and then perform one of the following:
 - To enter a value in this field, press the + or – button to set the design flow GPM.
 - To have the value set through a learn flow operation, refer to Learning Flow by Zone on page 85.
7. Press the **Next** button to move to the **Managed by Flow** field. When you set up the design flow for the mainline and then set this field to YES, the controller will use the design flow of the individual zones (or learned flow) and will turn on zones that are waiting to water until their design flow is equal to or less than the available flow on the mainline. Press the + button to display **YES** in the field.
8. Press the **Next** button to move to the **Flow Variance Zone Detect** field. Flow variance is the actual flow compared to the expected flow. Both above and below expected flow conditions can be detected and then acted upon. Press the + button to display a percentage in the field.
9. Press the **Next** button to move to the **Shut down** field. If you want the mainline to turn off when the flow variance exceeds this limit, press the + button to enter a **Y** (yes) in the field. If you do not want the flow variance to shut down the system, enter an **N** (no) in the field.
10. When you have finished making changes, turn the dial to the **RUN** position.

Setup Mainline	Flow
Mainline {Mainline 1}	<input type="text" value="1"/>
Use this Mainline	<input type="text" value="YES"/>
Design Flow (GPM)	<input type="text" value="20.0"/>
Manage by Flow	<input type="text" value="NO"/>
Flow Variance Zone Detect	<input type="text" value="10 %"/> <input type="text" value="N"/>
[WS1] --> [CP1] --> [ML1]	
<input type="button" value="Help"/>	

Setting Up the Hydraulic Layout

To get the most out of the flow management and monitoring capabilities in the BaseStation 3200, it's useful to build a reasonably accurate model of your actual hydraulic system in the BaseStation 3200.

It's useful to refer to an as built drawing or a map of your hydraulic system when you are setting up the layout in the BaseStation 3200. In particular, it's important to know which mainlines your zones are connected to so you can represent your actual system in the BaseStation 3200.

Connecting a Water Source to a Control Point

Each water source must be connected to at least one control point.

1. Turn the dial to the **Water Sources** position.
2. Press the **Next** button to select the **Assign Water Sources to Control Points** option.
3. Press the **Enter** button. The WS→CP screen displays.

4. Press the + or – button to select any available water source in the left column.

Note: If you don't see any water sources in the left column, press the + button to move down in the list.

5. Press the **Next** or **Previous** button to move to the **Control Points** column and select an available control point.

6. Press the **Enter** button to connect the water source to that control point.

7. Perform one of the following options:

- If you want to connect another water source to a control point, repeat steps 4 – 6.
- If you have finished making changes, turn the dial to the **RUN** position.

WS→CP		Water Sources	
Water Sources		Control Points	
-		CP1	WS1
-		CP2	WS2
-	Press Enter	CP3	WS3
WS4	<----->	CP4	-
WS5		CP5	-
WS6		CP6	-
- or + Key		Previous or Next Key	

Connecting a Control Point to a Mainline

1. Turn the dial to the **Water Sources** or **Flow** position.
2. Press the **Next** or **Previous** button to select the **Assign Control Points to Mainlines** option.
3. Press the **Enter** button. The CP →ML screen displays.

4. Press the + or – button to select any control point in the left column.

5. Press the **Next** or **Previous** button to move to the **Mainline Assignment** column.

6. Press the + or – button to select the mainline that you want the control point to be connected to.

7. Perform one of the following options:

- If you want to connect another control point to a mainline, press the **Previous** button to return to the left column, and then repeat steps 4 – 6.
- If you have finished making changes, turn the dial to the **RUN** position.

CP→ML		Water Sources	
Control Point		Mainline Assignment	
CP1		ML-1	
CP2		ML-2	
CP3		ML-3	
CP4		None	
CP5		None	
CP6		None	
[WS3] --> [CP3] --> [ML3]			
			Help

Assigning Zones to Mainlines

1. Turn the dial to the **Flow** position.
2. Press the **Next** or **Previous** button to select the **Assign Zones to Mainlines** option.
3. Press the **Enter** button. The Zones → ML screen displays.
4. Press the + or – button to select any zone in the left column.
5. Press the **Next** button to move to the **Mainline** column.
6. Press the + or – button to select the mainline that you want the zone to be assigned to.
7. Press the **Next** button to move to the **Zone Flow** column.
8. Press the + or – button to set the value of the GPM flow for this zone.
9. Perform one of the following options:
 - If you want to assign another zone to a mainline, press the **Previous** button to return to the left column, and then repeat steps 4 – 8.
 - If you have finished making changes, turn the dial to the **RUN** position.

Zones --> ML		Flow	
Zones	Mainline	Zone Flow	
-	-	-	
-	-	-	
ZN 1	ML1	20.5	
ZN 2	ML2	20.5	
ZN 3	ML3	20.5	
-	-	-	

{Zone 1}
{Mainline 1}

Help

Assigning Devices to a Control Point

The BaseStation 3200 supports 8 control points (CPs). You can assign master valves, pumps, flow biCoders, and pressure sensors to the control points.

Note: You must have the individual devices assigned to an address in the controller before you can assign them to a control point. Refer to Searching for and Assigning Devices on page 35.

1. Turn the dial to the **Water Sources** position.
 2. Press the **Next** button to select the **Assign Devices to Control Points** option.
 3. Press the **Enter** button. The Devices→CP screen displays.
 4. In the **Control Point** field, press the + or – button to select the control point that you want to assign devices to.
- IMPORTANT NOTE!** A device can only be assigned to one control point.
5. Press the **Next** button to move to the **Master Valve** field, and then press the + button to find the device that you want to assign.
 6. Press the **Next** button to move to the **Enabled** field. By default, the master valve is enabled. Press the + or – button to change the setting to disabled as needed.

Devices-->CP		Water Sources	
		Control Point {Control Point 1}	CP1
Master Valve	Enabled	Normally Open	
MV 2	<input checked="" type="checkbox"/>	NO	
Pump	Enabled		
-	<input type="checkbox"/>		
Flow biCoder	Enabled	K-Value	Pulses/Gal
FM 2	<input checked="" type="checkbox"/>	0.311	193
Pressure	Enabled	4 ma value	20 ma value
PR 1	<input checked="" type="checkbox"/>	0.00	150.00

Help

7. Press the **Next** button to move to the **Normally Open** field, and then press the + or – button to toggle the value in the field between **YES** and **NO**.
8. Press the **Next** button to move to the **Pump** field, and then press the + button to find the device that you want to assign.
9. Press the **Next** button to move to the **Enabled** field. By default, the pump is enabled. Press the + or – button to change the setting to disabled as needed.
10. Press the **Next** button to move to the **Flow biCoder** field, and then press the + button to find the device that you want to assign.
11. Press the **Next** button to move to the **Enabled** field. By default, the flow biCoder is enabled. Press the + or – button to change the setting to disabled as needed.
12. Press the **Next** button to move to the **K-Value** field. Press the + or – button to enter the calibration factor for the flow device that this flow biCoder is connected to.
13. Press the **Next** button to move to the **Pulses/Gal** field. Press the + or – button to enter the calibration factor for the flow device that this flow biCoder is connected to.
14. Press the **Next** button to move to the **Pressure** field, and then press the + button to find the device that you want to assign.
15. Press the **Next** button to move to the **Enabled** field. By default, the pressure biCoder is enabled. Press the + or – button to change the setting to disabled as needed.
16. Press the **Next** button to move to the **4 ma value** field. Press the + or – button to set the value in this field to the minimum reading when the sensor is at 4mA.
17. Press the **Next** button to move to the **20 ma value** field. Press the + or – button to set the value in this field to the maximum reading when the sensor is at 20mA.
18. When you have finished making changes, turn the dial to the **RUN** position.

Setting Up Conditions for Water Management

Setting Up an Empty Condition for a Water Source

If one of your water sources is a cistern or reservoir, you can install a moisture sensor, an event switch (float), or a pressure sensor to monitor the water level and stop using that water source when the water drops below a specified level.

1. Turn the dial to the **Water Sources** position.
2. Press the **Next** or **Previous** button to select the **Water Source Conditions** option, and then press the **Enter** button. The WS Conditions submenu displays and the Empty Conditions option is highlighted.
3. Press the **Enter** button. The WS Empty screen displays.

4. In the **Water Source** field, press the + or – button to select the water source that you want to create an empty condition for.
5. Press the **Next** button to move to the Devices column on the left.
6. Press the + or – button to select the device that you want to assign to this empty condition.
7. Press the **Enter** button. The column beside the device shows a Y to indicate that it is selected.
8. If you want the condition to be active, make sure to set the **Enabled** field to **YES**.
9. Press the **Next** button to move to the condition fields. These fields vary depending on the type of device selected in the Devices column. Complete all the fields to set up the condition.
10. In the **Wait Time** field, press the + or – button to set the minimum duration for the empty condition. When this time is up, the controller evaluates the water source to determine whether water is available again. If so, the empty condition is cleared. If not, the wait time starts over again.
11. When you have finished making changes, turn the dial to the **RUN** position.

WS Empty		Water Sources	
		Water Source {Well}	<input type="text" value="WS1"/>
		Enabled	<input type="text" value="YES"/>
Devices		Limit	<input type="text" value="15.0%"/>
<input type="text" value="-"/>	<input type="text" value="-"/>	Wait Time	<input type="text" value="0:10"/>
<input type="text" value="-"/>	<input type="text" value="-"/>		
<input type="text" value="MS 1"/>	<input type="text" value="Y"/>		
<input type="text" value="EV 1"/>	<input type="text" value=""/>		
<input type="text" value="EV 2"/>	<input type="text" value=""/>		
[WS1] --> [CP1] --> [ML1]			
<input type="button" value="Help"/>			

Setting Up Control Point Conditions

These features will be implemented in a future release.

Setting Up Mainline Conditions

Delaying a Zone Start Based on Time

1. Turn the dial to the **Flow** position.
2. Press the **Next** or **Previous** button to select the **Mainline Conditions** option, and then press the **Enter** button. The ML Conditions submenu displays and the Delay Zone Starts option is highlighted.
3. Press the **Enter** button. The Zone Delay screen displays.
4. In the **Mainline Number** field, press the + or – button to select the mainline that you want to create a delayed start for.
5. Press the **Next** button to move to the **Pipe Fill/Stabilize Type** field. Press the + or – button to toggle the setting between Time and Pressure. Depending on which option you select, the next field displays for the corresponding value – either minutes or PSI.

Zone Delay		Flow	
Mainline Number {Mainline 1}	<input type="text" value="1"/>		
Pipe Fill/Stabilize Type	<input type="text" value="Time"/>		
Pipe Fill/Stabilize	<input type="text" value="2"/>	min	
Delay Type	<input type="text" value="Time"/>		
Delay before first zone	<input type="text" value="3"/>	min	
Delay before next turn on	<input type="text" value="3"/>	min	
Delay after last zone	<input type="text" value="3"/>	min	
Number of zones	<input type="text" value="10"/>		
<input type="button" value="Help"/>			

6. Press the **Next** button to move to the **Pipe Fill/Stabilize** field, and then press the + or – button to enter the amount of time or pressure that it takes to fill the pipe and achieve a steady flow rate after a valve change.
7. Press the **Next** button to move to the **Delay Type** field. Press the + or – button until **Time** displays in the field.
8. Press the **Next** button to move through the next 3 fields, and press the + or – button to set the number of minutes as needed.
9. Press the **Next** button to move to the **Number of zones** field, and then press the + or – button to set the maximum number of zones to be turned on at a time when the delay is active.
10. When you have finished making changes, turn the dial to the **RUN** position.

Delaying a Zone Start Based on Pressure

If your irrigation system has a pump that needs to build pressure before the first zone on a mainline turns on, you can delay the start of a zone based on a specific pressure reading.

Note: In order to operate the zone delay based on pressure, a pressure sensor must be assigned to the control point that this mainline is connected to. Refer to Assigning Devices to a Control Point on page 80.

1. Turn the dial to the **Flow** position.
2. Press the **Next** or **Previous** button to select the **Mainline Conditions** option, and then press the **Enter** button. The ML Conditions submenu displays and the Delay Zone Starts option is highlighted.
3. Press the **Enter** button. The Zone Delay screen displays.
4. In the **Mainline Number** field, press the + or – button to select the mainline that you want to create a delayed start for.
5. Press the **Next** button to move to the **Pipe Fill/Stabilize Type** field. Press the + or – button to toggle the setting between Time and Pressure. Depending on which option you select, the next field displays for the corresponding value – either minutes or PSI.

Zone Delay	Flow
Mainline Number (Mainline 1)	<input type="text" value="1"/>
Pipe Fill/Stabilize Type Pipe Fill/Stabilize	<input type="text" value="Time"/> <input type="text" value="2"/> min
Delay Type	<input type="text" value="Pressure"/>
Delay before first zone	<input type="text" value="40.00"/> psi
Delay before next turn on	<input type="text" value="40.00"/> psi
Delay after last zone	<input type="text" value="0.00"/> psi
Number of zones	<input type="text" value="10"/>
<input type="button" value="Help"/>	

6. Press the **Next** button to move to the **Pipe Fill/Stabilize** field, and then press the + or – button to enter the amount of time or pressure that it takes to fill the pipe and achieve a steady flow rate after a valve change.
7. Press the **Next** button to move to the **Delay Type** field. Press the + or – button until **Pressure** displays in the field.
8. Press the **Next** button to move through the next 3 fields, and press the + or – button to set the PSI values as needed.
9. Press the **Next** button to move to the **Number of zones** field, and then press the + or – button to set the maximum number of zones to be turned on at a time when the delay is active.
10. When you have finished making changes, turn the dial to the **RUN** position.

Setting Up Advanced Flow Variance

The BaseStation 3200 controller gives you powerful tools for managing flow variance on your irrigation system mainlines. If a variance is detected, the controller will first shut down any operating zones and monitor the mainline to determine whether there is a fault. If not, the controller will then proceed to identify the zone that is above variance and shut it down.

You can set above and below variance percentages for GPM ranges. Depending on your settings, the controller monitors the flow within the range and shuts down the mainline if the measured variance is above/below the set percentage limit.

1. Turn the dial to the **Flow** position.
2. Press the **Next** or **Previous** button to select the **Mainline Conditions** option, and then press the **Enter** button. The ML Conditions submenu displays.
3. Press the **Next** button to move to the **Advanced Flow Variance** option, and then press the **Enter** button. The Advanced Variance screen displays.
4. In the **Mainline Number** field, press the + or – button to select the mainline that you want to set up advanced flow variance for.
5. Press the **Next** button to move to the **Enabled** field. Press the + or – button to toggle the setting between YES and NO. If you want advanced flow variance to be active on this mainline, make sure the field is set to YES.
6. Press the **Next** button to move to the first GPM range field.
7. Press the **Next** button to move through the fields, and press the + or – button to set the variance percentages as needed.
8. Press the **Next** button to move to the **Enable Shutdowns** field, and perform one or both of the following options:
 - To enable a shutdown when the measured variance is **above** the set percentage limit, press the + or – button to show **YES** in the field.
 - To enable a shutdown when the measured variance is **below** the set percentage limit, press the + or – button to show **YES** in the field.
9. When you have finished making changes, turn the dial to the **RUN** position.

Advanced Variance	Flow	
Mainline {Mainline 1}	1	
Enabled	YES	
	Above	Below
Flow below 25 GPM	10 %	10 %
Flow from 25 to 100 GPM	10 %	10 %
Flow from 100 to 300 GPM	5 %	5 %
Flow above 300 GPM	5 %	5 %
Enable Shutdowns	YES	YES
Help		

Setting Up Advanced Dynamic Flow Allocation

If you enable Advanced Dynamic Flow Allocation on a mainline, the controller evaluates the required GPM when a zone requests water. Then the water is routed through the smallest flow meter that can accommodate that flow. In this way, the system is able to report more accurate flow readings.

1. Turn the dial to the **Flow** position.
2. Press the **Next** or **Previous** button to select the **Mainline Conditions** option, and then press the **Enter** button. The ML Conditions submenu displays.
3. Press the **Next** button to move to the **Advanced Dynamic Flow Allocation** option, and then press the **Enter** button. The Adv Allocation screen displays.
4. In the **Mainline Number** field, press the + or – button to select the mainline that you want to set up Advanced Dynamic Flow Allocation for.
5. Press the **Next** button to move to the **Dynamic Allocation Enabled** field, and then press the + or – button to show **YES** in the field.
6. When you have finished making changes, turn the dial to the **RUN** position.

Adv Allocation	Flow
Mainline {Mainline 1}	<input type="text" value="1"/>
Dynamic Allocation Enabled	<input type="text" value="YES"/>
<input type="button" value="Help"/>	

Learning Flow

With one or more flow devices, the BaseStation 3200 has the ability to do a learn flow cycle to determine the flow for zones. You can run the learn flow cycle either for individual zones or by program. You can set up the learn flow cycle to be delayed from 15 minutes to 23 hours and 45 minutes. You can set multiple programs to learn the flow, each at a different time, or the same time. When you schedule a learn flow cycle, it only runs one time.

Learning Flow by Zone

For each zone, you can either set the design flow manually, or you can configure it to run through a learn flow cycle and have its design flow set automatically. You should reconfigure the design flow for a zone whenever you change out a sprinkler or emitter on a zone or whenever the learn flow cycle fails for a zone.

Note: The zone must be assigned to a mainline in order to run a zone learn flow operation.

1. Turn the dial to the **Flow** position.
2. Press the **Next** button to select the **Zone Learn Flow Operations** option.

- Press the **Enter** button. The Zone Learn Flow screen displays.
- In the **Zone** field, press the + button to select the zone that you want to schedule a learn flow cycle for.
- Press the **Next** button to go to the **Status** field. If the system already ran a learn flow cycle for this zone, the status of that cycle (complete or failed) displays in the field. To schedule a learn flow cycle, press the + button to advance the delay time by 5 minutes.
- When you have finished scheduling the learn flow cycle, turn the dial to the **RUN** position.

Zone Learn Flow		Flow
Zone	Status	Date
-	-	-
-	-	-
1	Scheduled	10/14/14 12:28PM
2	Not Yet	-
3	Not Yet	-
-	-	-

{Zone 1}

Help

IMPORTANT NOTE! The learn flow cycle does not start until you turn the dial to the RUN position.

When the learn flow cycle completes, the value is displayed in the Flow field on the Zone Setup screen for the specific zone.

Learning Flow by Program

- Turn the dial to the **Flow** position.
- Press the **Next** button to select the **Program Learn Flow Operations** option.
- Press the **Enter** button. The Prog Learn Flow screen displays.
- In the **Program** column, press the + button to move to the program that you want to schedule a learn flow cycle for.
- Press the **Next** button to move to the **Status** column, and then press the + button to toggle the setting between Pending and Not Yet.
- Press the **Next** button to move to the **Date** column, and then press the + button set the learn time in 5 minute increments in the future, up to about 24 hours.

Prog Learn Flow		Flow
Program	Status	Date
-	-	-
-	-	-
PG-1	Pending	6/6/12 1:34PM
PG-2	Not Yet	Not Yet
PG-3	na	Not Yet
PG-4	na	Not Yet

Prog Zones: 1,2,3,4,5...

Help

Note: At the 24 hour point the status will return to Not Yet.

- When you have finished setting up the learn flow cycle, turn the dial to the **RUN** position.

IMPORTANT NOTE! The learn flow cycle does not start until you turn the dial to the RUN position. Depending on how many zones a program has, the learn flow cycle could take more than an hour to complete.

When the learn flow cycle begins, it will pause any running programs (on that mainline), and it will run one zone at a time to learn its flow. The controller takes an average of multiple readings. If the readings vary too much, the learn flow process will fail. When the learn flow cycle completes, the value is displayed in the Flow field on the Zone Setup screen for each zone.

8 – Manual Operations

The BaseStation 3200 has several options that enable you to manually control your irrigation system. You can force a program to start, stop a program that is actively watering, or set the next start date for a program.

You can also manually water a single zone, all zones, or the zones of a program, and you can manually run a pump, a master valve, or zones that are used to operate lights or locks. The manual run options are useful for doing a walk-around test, or for applying additional water for a short period of time to a specific zone.

Forcing a Program to Start

When you use this option to start a program, the zones water according to the program including water times, soak times, and sensor conditions.

If you want to manually run the zones in a program for a specified amount of time, refer to Manually Running Programs for a Fixed Time on page 90.

1. Turn the dial to the **Manual** position.
2. Press the **Next** button to select the **Start or Stop Program(s)** option.
3. Press the **Enter** button. The Prog Start/Stop screen displays.
4. In the **Program/Status** column, press the **+** button to select an idle or paused program that you want to start.

Note: The zones in the selected program display under the Program/Status column and any conditions that affect the manual run also display.

5. Press the **Next** button to move to the **Start/Stop** column. The field in this column displays **Start**.
6. Press the **+** button. The field in the Start/Stop column displays **Stop**, and the program's status changes to **Watering**.
7. To start the manual run, turn the dial to the **RUN** position.

Prog Start/Stop		Manual
Program/Status		Start/Stop
-	-	-
1	Watering	Stop
2	Idle	Start
3	Idle	Start
4	Idle	Start
5	Idle	Start
Prog 2 Zones: 5,6,7,8		
*** Active Pause: Water Window ***		
Turn Dial to RUN to Start		<input type="button" value="Help"/>

Stopping an Active Program

1. Turn the dial to the **Manual** position.
2. Press the **Next** button to select the **Start or Stop Program(s)** option.
3. Press the **Enter** button. The Prog Start/Stop screen displays.
4. In the **Program/Status** column, press the + button to select a watering program that you want to stop.
5. Press the **Next** button to move to the **Start/Stop** column. The field in this column displays **Stop**.
6. Press the + button. The field in the Start/Stop column displays **Start**, and the program's status changes to **Idle**.
7. Turn the dial to the **RUN** position.

Prog Start/Stop		Manual
Program/Status		Start/Stop
-	-	-
-	-	-
1	Watering	Stop
2	Idle	Start
3	Idle	Start
4	Idle	Start
Prog 1 Zones: 1,2,3,4,5...		
Turn Dial to RUN to Start		Help

Manually Starting/Stopping the Zones of a Program

You can manually run one or more zones of a program for their programmed water times. You can also use this option to stop one or more zones of a program that is currently running.

Example: After zones 1 – 3 of program 1 ran, you had to stop watering. Later, you manually start program 1 again, and you can use this option to set zones 1 – 3 to done because they ran earlier.

1. Turn the dial to the **Manual** position.
2. Press the **Next** button to select the **Start or Stop Program Zone(s)** option.
3. Press the **Enter** button. The Zone Start/Stop screen displays.
4. In the **Prog** column, press the + button to select the program that has the zones that you want to run.
5. Press the **Next** button to move to the **Zone/Status** column.
6. Press the + button to select the zone that you want to run.
7. Press the **Next** button to move to the **Start/Stop** column. The field in this column displays **Start**.
8. Press the + button. The field in the Start/Stop column displays **Stop**, and the program's status changes to **Watering**.

Zone Start/Stop		Manual
Prog	Zone/Status	Start/Stop
-	-	-
-	-	-
1	1 Sprinkling	Stop
2	2 Done	Start
3	3 Done	Start
4	4 Done	Start
Prog 1 Zones: 1,2,3,4,5...		
Turn Dial to RUN to Start		Help

9. If you want to manually run another zone in the program, press the **Previous** button to return to the **Zone/Status** column. Repeat steps 6 – 8 to start another zone.
10. To start the manual run, turn the dial to the **RUN** position.

Manually Running One or All Zones for a Fixed Time

If you want to manually run a zone on a shared mainline (one that has been turned over to the FlowStation), you must use the Run One or All Zones for Fixed Time option. This option can also be used to manually run zones on local mainlines.

1. Turn the dial to the **Manual** position.
2. If the **Run One or All Zones for Fixed Time** option is highlighted, press the **Enter** button. If the option is not highlighted, press the **Next** or **Previous** button to select it, and then press the **Enter** button. The Manual One/All screen displays.
3. In the **Zone** column, press the **+** button to select **ALL** or the zone that you want to run.
4. Press the **Next** button to move to the **Run Time** field, and then press the **+** or **-** button to set the amount of time for the manual run.
5. Press the **Next** button to move to the **Initial Delay** field. If you want the controller to delay the start of the manual run to give you time to walk to the zone location, press the **+** or **-** button to set the amount of time for the delay.
6. Press the **Next** button to move to the **Between Zone Delay** field. If you chose **ALL** in the Zone column, you can use this field to set a delay between each zone. Press the **+** or **-** button to set the amount of time for the delay.
7. When you have finished making changes, turn the dial to the **RUN** position. When the manual run starts, the main screen shows the details.
8. If you want to stop the manual run while it is active, press the **Back** button.

Manual One/All	Manual
Zone	h:mm:ss
None	Run Time <input type="text" value="0:01:00"/>
All	Initial Delay <input type="text" value="0:00:00"/>
1	Between Zone Delay <input type="text" value="0:00:00"/>
2	ML 1 + POC(s)
3	
-	
{Zone 1}	
Turn Dial to RUN to Start <input type="button" value="Help"/>	

7 Message(s)	RUN
{Aspen Park}	
3:58:27 PM	BaseMgr: Connected
Fri - 1/19/2018	Two-wire: 0.84 Amps
	WF00884: 0.00 GPM
Manual Run - Zone(s)	
Zone 1 {Zone 1}	
Time Left = 0:00:49	
Valve Current/Voltage = 0.23 / 28.7	
Mainline 1 = 0.00 GPM	
<i>Press BACK to Stop</i>	

Manually Running Zones for a Fixed Time

1. Turn the dial to the **Manual** position.
2. If the **Run Zone(s) for Fixed Time** option is highlighted, press the **Enter** button. If the option is not highlighted, press the **Next** or **Previous** button to select it, and then press the **Enter** button. The Manual Zones screen displays.
3. In the **Zone** column, press the **+** button to select the zone that you want to run.
4. Press the **Next** button to move to the **Run Time** column, and then press the **+** or **-** button to set the amount of time for the manual run.
5. If you want to add another zone to the manual run, press the **Previous** button to return to the **Zone** column, and then repeat steps 3 – 4 to set the time for the next zone.
6. Press the **Next** button to move to the **Concurrent Zones** field. If you want more than one zone to run at one time during the manual run, press the **+** button to change the number in this field.
7. When you have finished making changes, turn the dial to the **RUN** position. When the manual run starts, the main screen shows the details.
8. If you want to stop the manual run while it is active, press the **Back** button.

Note: When the manual run is complete, the controller changes the Run Zone(s) for Fixed Time settings to Off.

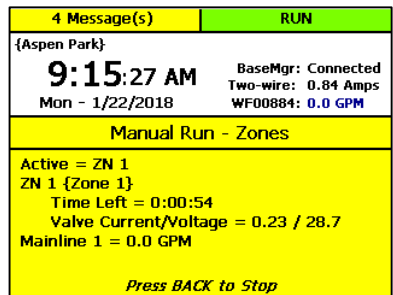
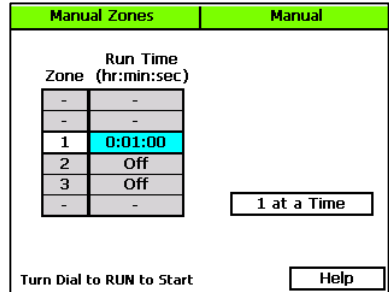

Manually Running Programs for a Fixed Time

1. Turn the dial to the **Manual** position.
2. Press the **Next** button to select the **Run Program(s) for Fixed Time** option.
3. Press the **Enter** button. The Manual Prog Zones screen displays.

- In the **Pgm** column, press the + button to select the program that you want to run.
- Press the **Next** button to move to the **Zone Time** column, and then press the + or – button to set the amount of time for the manual run.
- If you want to add another program to the manual run, press the **Previous** button to return to the **Pgm** column, and then repeat steps 4 – 5 to set the time for the next zone.

Manual Prog Zones		Manual
Pgm	Zone Time (hr:min:sec)	Concurrent Zones
-	-	-
-	-	-
1	0:01:00	2
2	Off	-
3	Off	-
4	Off	-

Programs to Run: 1
Turn Dial to RUN to Start Help

- Press the **Next** button to move to the **Concurrent Zones** column. If you want more than one zone to run at one time during the manual run, press the + button to change the number in this field.
- When you have finished making changes, turn the dial to the **RUN** position. When the manual run starts, the main screen shows the details.
- If you want to stop the manual run while it is active, press the **Back** button.

4 Message(s)	RUN
{Aspen Park}	
9:36:56 AM	BaseMgr: Connected
Mon - 1/22/2018	Two-wire: 0.84 Amps
	WF00884: 0.0 GPM
Manual Run - Program Zones	
Active = ZN 1	
ZN 1 {Zone 1}	
Time Left = 0:00:55	
Valve Current/Voltage = 0.23 / 28.7	
Mainline 1 = 0.0 GPM	
<i>Press BACK to Stop</i>	

Note: When the manual run is complete, the controller changes the Run Program(s) for Fixed Time settings to Off.

Manually Running a Pump or MV for a Fixed Time

If you want to get water to a hose bib that is attached to a master valve, you can use this option to manually turn on the MV for a specified amount of time. You can also use this option when you want to test all your lines.

This manual run operation pauses watering on the entire controller.

Note: You cannot manually run master valves and pumps that are assigned to a control point that is, in turn, assigned to a FlowStation.

- Turn the dial to the **Manual** position.
- Press the Next button to select the **Run Pump or MV for Fixed Time** option.
- Press the **Enter** button. The Manual Pump/MV screen displays.
- In the **Pump/MV** column, press the + button to select the pump or master valve that you want to run.
- Press the **Next** button to move to the **Run Time** column, and then press the + or – button to set the amount of time for the manual run.

Manual Pump/MVs		Manual
Pump /MV	Run Time (hr:min:sec)	Concurrent Pump/MVs
-	-	-
-	-	-
MV1	0:01:00	1 at a Time
-	-	-
-	-	-
-	-	-

Pump/MVs to Run: MV1
Turn Dial to RUN to Start Help

6. If you want to add another pump or master valve to the manual run, press the **Previous** button to return to the **Pump/MV** column, and then repeat steps 4 – 5 to set the time for the next pump or master valve.
7. Press the **Next** button to move to the **Concurrent Pump/MVs** field. If you want more than one pump or master valve to run at one time during the manual run, press the + button to change the number in this field.
8. When you have finished making changes, turn the dial to the **RUN** position. When the manual run starts, the main screen shows the details.
9. If you want to stop the manual run while it is active, press the **Back** button.

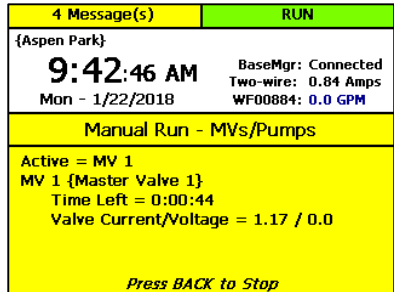

Note: When the manual run is complete, the controller changes the Run Pump or MV for Fixed Time settings to Off.

Setting the System to OFF

Turn the dial to the OFF position when you want to halt all watering for an indefinite period of time. No watering cycles will be started. Use this dial position for seasonal shutdown. DO NOT power down the BaseStation.

When set to OFF, the controller enforces the following conditions:

- All current watering cycles will be stopped and all zones will be set to Done.
- All booster pumps will be shut down.
- All local control points will be shut down.
- All learn flow processes and sensor calibration processes will be stopped.
- All manual run and manual test operations will be stopped.
- If the two-wire is set to always on (the default condition), it will remain powered on and readings will be taken from the following devices:
 - Flow biCoders
 - Moisture sensors
 - Pressure sensors
 - Temperature sensors
- If the two-wire is not set to always on, it will power down. However, the two-wire will power up every 10 minutes in order to take device readings.

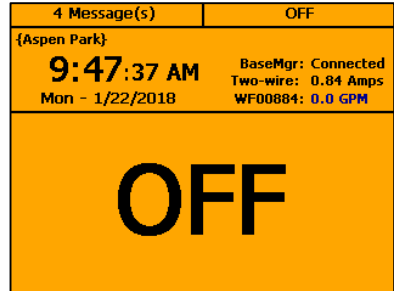

9 – System Management

The BaseStation 3200 has a number of features that enable you to manage the controller. You can select the language for the online help, set up personal identification numbers (PINs) to grant various levels of remote access to the controller. You can back up your system to a USB drive or to BaseManager, and then you can use those backup files to restore your system if it ever goes down. You can also ensure that your controller has the most current firmware with a download from the Baseline website.

Selecting the Language for Online Help

1. Turn the dial to the **Advanced** position.
2. If the **Select Language for Help Displays** option is highlighted, press the **Enter** button. If the option is not highlighted, press the **Next** or **Previous** button to select it, and then press the **Enter** button. The Help Language screen displays.
3. In the **Help Language** field, press the + button to toggle the setting between English and Spanish.
4. If you make a change to the language setting and you want to test the Online Help, press the **Next** button to select the **Help** field and then press the **Enter** button. The Online Help displays in the selected language. To return to the Help Language screen, press the **Back** button.

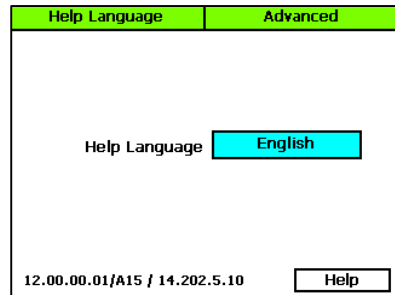

Setting Up Security for the Controller

In the BaseStation 3200, you can set up the following levels of security access:

- **Administrator:** Grants access to all controller functions
- **Programmer:** Grants access to most controller functions. On the Advanced menu, the programmer can access only the Data Management, Update Firmware, and System Settings options.
- **Operator:** Grants access to the Event Dates and Rain Delay Days in the Start, Stop, Pause menu, the Run menu, the Manual Run menu, and the Test menu. The operator can also view reports and messages.

After you enable the security and set up the PINs, restart the controller. Users will be prompted to enter their PIN when they press one of the menu buttons on the controller. If the user does not have access to the menu, he/she will see the message “Invalid PIN.”

IMPORTANT NOTE! When a user accesses the controller with a PIN, the controller will maintain that level of access until the dial is turned to RUN.

1. Turn the dial to the **Advanced** position.
2. Press the **Next** button to select the **Security Setup** option, and then press the **Enter** button. The Security screen displays.
3. In the **Enable Security Levels** field, press the + button to toggle between Enabled and Disabled.
4. Press the **Next** button to select the first digit of the Administrator PIN, and then press the + or – button to change the number.
5. Press the **Next** button to move to the next digit, and then press the + or – button to change the number. Repeat this step until you have configured all digits of the PIN.
6. Press the **Next** button to select the next PIN, and then repeat steps 4 and 5 until you have configured all of the PINs.

Note: Be sure to remember which PIN is associated with which access level so you are certain to give the correct PIN to the correct users.

7. When you have finished making changes, return the dial to the **RUN** position.

Changing the Two-Wire Always On Setting

In its default condition, the controller always supplies power to the two-wire even when the dial is turned to OFF. However, you can change this setting so that after 1 minute of idle time, the controller will power down the two-wire. Keep in mind if you have a normally open master valve that is not connected to a separate power source or you have a coach's button that can be used at any time, you should set the two-wire to be always on.

Additionally, if you are using a testing device to troubleshoot an issue with the two-wire, you should set the two-wire to be always on.

Note: If you need to power down the two-wire immediately, you can disconnect the wire from the controller, or you can power down the controller.

1. Turn the dial to the **Advanced** position.
2. Press the **Next** button to select the **Two-wire Settings** option, and then press the **Enter** button. The Two-wire Settings screen displays.
3. In the **Two-wire Always On** field, press the + or – button to toggle between **YES** and **NO**.

Changing the Serial Number of Your Controller

The System Settings option under the Advanced dial position allows you to change the serial number of your controller. It also provides a set of system functions that you should only perform under direction from Baseline Support.

CAUTION! Only change the serial number of your controller when directed to do so by Baseline Support. If you change the serial number, you will disable your ability to restore your system from a previous backup.

Also be aware that it is easy to inadvertently change the serial number when you are in this screen. We recommend that you avoid accessing this screen unless you are directed to do so by Baseline Support.

1. Turn the dial to the **Advanced** position.
2. Press the **Next** button to select the **System Settings** option, and then press the **Enter** button. The System Settings screen displays.
3. Press the + or – button to change the number in the first digit of the serial number.
4. Press **Next** button to select the next digit of the serial number, and then press the + or – button to change the number. Repeat this step to change the numbers in all digits.
5. Perform one of the following options:
 - To save the changes to the serial number, press the **Enter** button.
 - To exit the screen without making a change, press the **Back** button.

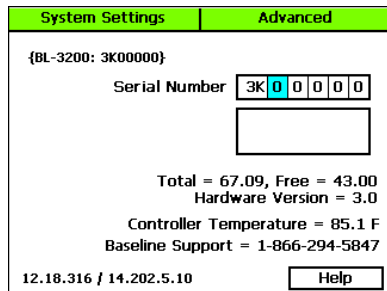

Backing Up Your Controller to a USB Drive

After you have created a stable program on your controller, you should create a backup of your program data. Likewise, if you make any programming changes, be sure to create a new backup to capture those changes. You should also create a backup before you do a firmware update on your controller. The backup will allow you to restore to the previous programming if anything goes wrong.

Note: Use a standard USB drive for these functions. A multi-function USB memory device, such as an MP3 player, is not compatible with these functions.

1. Turn the dial to the **Advanced** position.
2. Plug a USB drive into the USB port on the faceplate of the controller.
CAUTION! To avoid damaging the connector pins, gently push the drive into the port.
3. Press the **Next** button to move to the **Data Management** option, and then press the **Enter** button. The Data Mgmt screen displays.

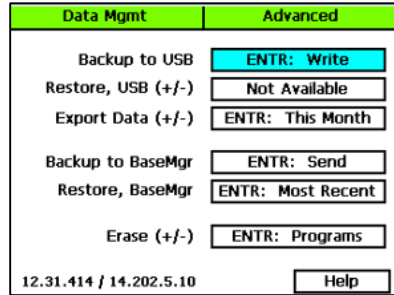

4. In the **Backup to USB** field, the **Write** option is highlighted. Press the **Enter** button. The controller writes a copy of the current programming to the USB drive. The data is saved in a folder that is the same as the serial number of the controller (such as 3K0001). The file is named Backup2_YYMMdd.zip. The controller can write up to 10 backup files, each from a different date.

Note: The controller does not notify you when the backup is complete. Leave the USB drive in the port for at least a minute before proceeding to step 5.

5. Unplug the USB drive from the port, and then turn the dial back to the **RUN** position.

Note: You can leave the backup data on the USB drive until you need it for a restore. However, if you need the USB drive for another purpose, you can also copy the data to a computer. Just make sure that you maintain the same folder structure, folder names, and file names, so you can copy it back to the USB drive if you need to use it to restore your data.

Backing Up Your Controller to BaseManager

If your controller is connected to BaseManager, you can save a backup file.

1. Turn the dial to the **Advanced** position.
2. Press the **Next** button to move to the **Data Management** option, and then press the **Enter** button. The Data Mgmt screen displays.
3. Press the **Next** button to move to the **Backup to BaseMgr** option.
4. Press the **Enter** button.

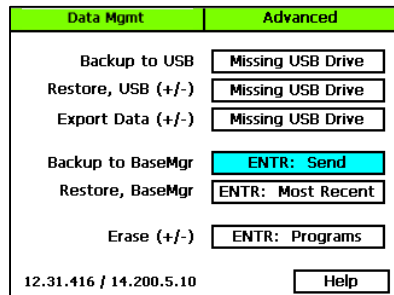

Note: The controller does not notify you when the backup is complete. Wait for at least a minute before proceeding to step 5.

5. Turn the dial back to the **RUN** position

Restoring Your Controller from a USB Drive

If your controller has lost its programming data or if you want to revert to a previous configuration, you can restore from a backup that you previously saved on a USB drive.

1. Plug the USB drive that has the backup data on it into the USB port on the faceplate of the controller.
2. Turn the dial to the **Advanced** position.
3. Press the **Next** button to move to the **Data Management** option, and then press the **Enter** button. The Data Mgt screen displays. When the controller finds the backup data on the USB drive, the backup date is listed as an available restore point within the Restore option box.
4. Press the **Next** button to select the **Restore, USB** option, and then perform one of the following options:
 - If the restore point that you want to use is listed in the Restore option box, press the **Enter** button. The controller replaces the current programming with the copy from the USB drive.
 - If a USB drive has multiple backup files for this controller, you can cycle through them by pressing the + or – button to display the dates of the available restore points. When the one that you want to use displays, press the **Enter** button.

While the data is being written to the controller, you might notice the word “Busy” displayed in the status bar at the top left of the controller screen. When the Restore procedure is complete, the controller displays a message.

5. When the controller finishes copying the data from the USB drive, unplug the drive from the port, and then turn the dial back to the **RUN** position.

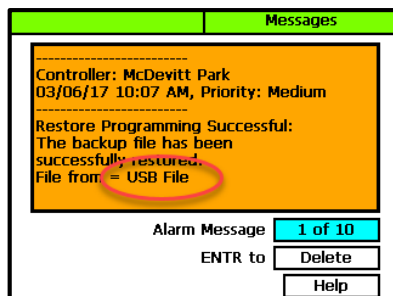

Restoring Your Controller from BaseManager

If your controller has lost its programming data or if you want to revert to a previous configuration, you can restore from a backup that you previously saved to BaseManager (if your controller is connected).

1. Turn the dial to the **Advanced** position.
2. Press the **Next** button to move to the **Data Management** option, and then press the **Enter** button. The Data Mgt screen displays.

3. Press the **Next** button to select the **Restore, BaseMgr** option, and then press the **Enter** button.

While the data is being written to the controller, you might notice the word “Busy” displayed in the status bar at the top left of the controller screen. When the Restore procedure is complete, the controller displays a message.

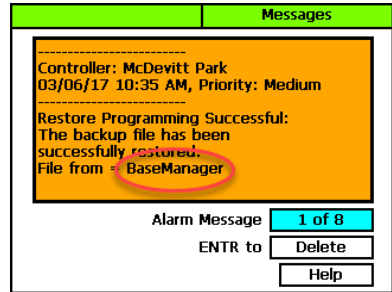

4. Turn the dial back to the **RUN** position.

Exporting Controller Data

The BaseStation 3200 saves up to 2 years of log files. The controller records all programming changes, water times, moisture levels, and other internal information in these files. The daily files are saved in folders by month. When you perform an export, all of the files are copied to the USB drive in the controller serial number folder, and in a subfolder called Export.

Note: These files may be requested by Baseline Support.

1. Plug a USB drive into the USB port on the faceplate of the controller.
 - CAUTION!** To avoid damaging the connector pins, gently push the drive into the port.
2. Turn the dial to the **Advanced** position.
3. Press the **Next** button to move to the **Data Management** option, and then press the **Enter** button. The Data Mgmt screen displays.
4. Press the **Next** button to move to the **Export Data** option.
5. Press the **+ or –** button to select the range of data that you want to export:
 - This Month
 - Last Month
 - Everything

6. Press the **Enter** button. The controller exports the internal log files to the USB drive.

Note: The controller does not notify you when the export is complete. Wait for at least a minute before proceeding to step 7.

7. After the controller has finished copying the log files to the USB drive, unplug the drive from the port, and then turn the dial back to the **RUN** position.

Erasing All Programming from the Controller

This function will clear or erase all programming information in the controller. We recommend that you use this function only when directed by Baseline Support.

IMPORTANT NOTE! Never erase your programming data without having a current backup available for a restore. Refer to Backing Up Your Controller to a USB Drive on page 95 or Backing Up Your Controller to BaseManager on page 96.

1. Turn the dial to the **Advanced** position.
2. Press the **Next** button to move to the **Data Management** option, and then press the **Enter** button. The Data Mgmt screen displays.
3. Press the **Next** button to select the **Erase** option box.
4. Press the + or – button to set the option in the box to **Programs**.

Note: The other option in this box is Files. Select Files if you want to erase just the log files from the controller, but leave the programming.

CAUTION! Do not perform the next step unless you are certain that you want to erase your programming data – this option DOES NOT allow you to cancel the procedure after you press the Enter button.

5. Press the **Enter** button to erase the programs.

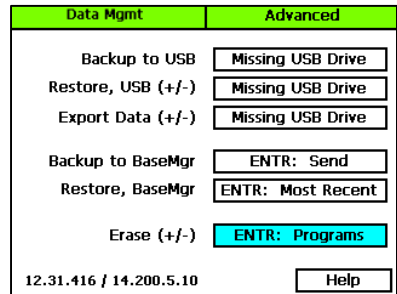

Erasing All Files from the Controller

This function will clear or erase all log files from the controller. We recommend that you use this function only when directed by Baseline Support.

1. Turn the dial to the **Advanced** position.
2. Press the **Next** button to move to the **Data Management** option, and then press the **Enter** button. The Data Mgmt screen displays.
3. Press the **Next** button to select the **Erase** option box.
4. Press the + or – button to set the option in the box to **Files**.

Note: The other option in this box is Programs. Select Programs if you want to erase all programming from the controller.

CAUTION! Do not perform the next step unless you are certain that you want to erase your files – this option DOES NOT allow you to cancel the procedure after you press the Enter button.

5. Press the **Enter** button to erase the files.

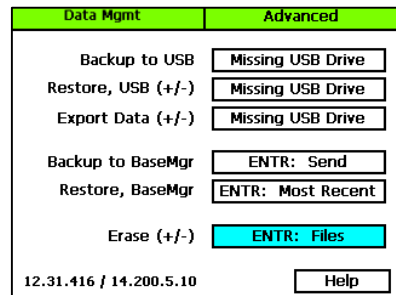

Updating the Controller Firmware

Firmware updates are free for the life of any Baseline controller as long as the hardware is compatible. Baseline will periodically release firmware updates that enhance the usefulness of our products or fix the occasional bug.

You will need a computer with a USB port. This computer must have access to the Internet. You also need a USB drive. You download the firmware from the Baseline website to the USB drive. Then, you take the USB drive to the controller and install the update.

We recommend that you back up your current configuration before starting this process in case you need to restore your system. Refer to *Backing Up Your System* on page 95.

Copying the Firmware Update from the Baseline Website onto a USB Drive

Note: The following procedure assumes that your computer is running Microsoft Windows.

1. On a computer that is connected to the Internet, go to the Baseline website at the following URL:
www.baselinesystems.com
2. On the home page, click **Support**.
3. In the left navigation bar, click **Firmware Updates**.
4. Click the **BaseStation 3200** tab.
5. Find the **V17 Firmware Update**, and then click the button to download the firmware.
6. When prompted, choose the **Save File** option, and then click **OK**. The file is automatically saved into the web browser's Download directory.
7. Plug a USB drive into a USB port on your computer.
8. When prompted in Windows, click the option to open the folder and view the files. A Windows File Explorer window opens and displays the contents of the USB drive.
9. In another Windows File Explorer window, find the **Update_XXX.bin** file in the Download directory.
10. Right-click on the **Update_XXX.bin** file, and then click **Copy**.
11. Go to the Windows File Explorer window for the USB drive.
12. Right-click in the file pane, and then click **Paste**. Ensure that the file is not copied into a folder on the USB drive.
13. Close the Windows File Explorer window for the USB drive.
14. In the System Tray area of your Windows Desktop, click the option to **Safely Remove Hardware and Eject Media**.
15. When the **Safe to Remove Hardware** message displays, unplug the USB drive from the computer.

Updating the Firmware on the Controller

1. On the BaseStation 3200 controller, plug the USB drive that has the Update files on it into the USB port.
2. Turn the dial to the **Advanced** position.
3. Press the **Next** button to move to the **Update Firmware** option, and then press the **Enter** button. The Update Firmware screen displays.
4. In the **Source of Update** field, verify that **USB** displays. The upper-left corner of the screen displays the progress. After the firmware update has been extracted, the new version number displays, and you can apply the update.
5. Press the **Next** button to move to the **ENTR: Update** field.
6. Press the **Enter** button to apply the firmware update.
7. After the controller has restarted, unplug the USB drive from the port.

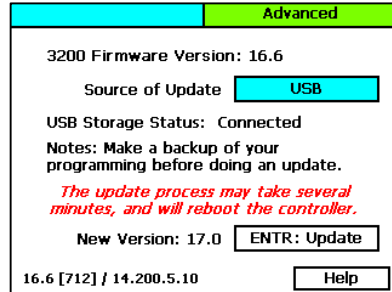

Note: If the firmware did not update as expected, please call Baseline Support at 866.294.5847.

Connecting to BaseManager – Overview

BaseManager is Baseline’s central control application available from the AppManager framework. BaseManager gives you remote access to your BaseStation 3200. In order to use BaseManager, your controller needs to be connected to a network with a supported communication module such as built-in Ethernet, Wi-Fi, Ethernet radio, or cell modem. You also need access to a BaseManager server – either Baseline’s server or your organization’s server.

- **Connecting to Baseline’s BaseManager Server:** The BaseStation 3200 is preconfigured to connect to Baseline’s BaseManager server. After you connect your controller to the network using a supported communication module, you can check the status of your connection on the RUN screen.
- **Connecting to Your Organization’s BaseManager Server:** Get the IP address of that server from your network administrator, and then configure the BaseStation 3200 to connect to that server with a static IP address. Refer to Connecting Your Controller to a Self-hosted BaseManager Server in the BaseManager Quick Start Guide.

Enabling the BaseManager Connection on the Controller

1. Turn the dial to the **Network** position.
2. Press the **Next** button to select the **BaseManager Server Setup** option, and then press **Enter**. The BaseManager screen displays.
3. Press the **Next** button to select the **Connect/Disconnect** field, and then press **Enter** to either connect or disconnect BaseManager.

BaseManager	Network
BaseMgr Status:	Connected
Press Enter to	Disconnect
Server URL Mode	DNS Lookup
IP Address	10 10 10 10
Physical (MAC) Address:	0008EE403A02
	p2.basemanager.net
	Help

Checking the Status of the BaseManager Connection

When your controller connects to the BaseManager server for the first time, the server detects the connection and checks for an associated BaseManager account. If no account is found, the server sends a registration code to your controller. The PIN briefly displays in a pop-up message as shown in the illustration. You need the PIN when you call Baseline to set up your BaseManager account. You also need the PIN to add a controller to an existing BaseManager account.

BUSY...	RUN
	{BL-3200: 3K00000}
3:22:00 PM	BaseMgr: Register
Tue	BaseManager Message
Pump	Authorization PIN is:
Prog 1	HGW69M
1	To authorize, login to:
11	p1.basemanager.net
21	12/11/12 15:32:00
31	BACK = Cancel / ENTER = Accept
41 - 50	
	Use +/- to view other zones
	ENTR for Help

After the message is dismissed from the display, you can find the PIN on the BaseManager screen.

1. Turn the dial on the BaseStation 3200 controller to **Network**.
2. Press the **Next** button to select the **BaseManager Server Setup** option and then, press the **Enter** button. The BaseManager screen displays.
3. Write down the PIN found in the **Registration Code** field on this screen.
4. Write down the MAC address of the BaseStation 3200 controller found in the **Physical (MAC) Address** field on this screen.

BaseManager	Network
BaseMgr Status:	Connected
Press Enter to	Disconnect
Server URL Mode	DNS Lookup
IP Address	10 10 10 10
Physical (MAC) Address:	0008EE403A02
	p2.basemanager.net
	Registration Code: eWMuax
	Help

Activating Your BaseManager Subscription

When you are ready to activate your BaseManager subscription, call Baseline Support at 866-294-5847.

Baseline Support will assign the company admin username and password. The admin can change this password after logging in for the first time.

If you already have a BaseManager subscription and you are just connecting a new controller to BaseManager, you don't need to create another subscription. Just be sure to write down the authorization PIN that displays on your controller when it's connected. Then you will use that PIN to add the controller to your existing BaseManager subscription. Refer to the Adding Controllers topic in the BaseManager Help.

Setting Up the Default Network Connection

By default the controller uses the Dynamic Host Configuration Protocol (DHCP) to have the IP address automatically set by the network.

1. Connect and configure the communication module. Check the status lights and indicators on your communication equipment to ensure that it is powered up and appears to be sending and receiving data.
2. On the controller, turn the dial to the **Network** position.
3. Press the **Next** button to select the **Ethernet Setup** option, and then press **Enter**. The Ethernet screen displays.
4. Make sure that **DHCP** displays in the **IP Address Mode** field. If it does not, press the + or – button to change the value to **DHCP**.

Ethernet	Network
IP Address Mode	DHCP
IP Address	<input type="text"/> <input type="text"/> <input type="text"/> <input type="text"/>
Subnet Mask	255 255 255 0
Default Gateway	<input type="text"/> <input type="text"/> <input type="text"/> <input type="text"/>
Preferred DNS Server	<input type="text"/> <input type="text"/> <input type="text"/> <input type="text"/>
Preferred DNS Server	<input type="text"/> <input type="text"/> <input type="text"/> <input type="text"/>
<input type="button" value="Help"/>	

Note: For a definition of the fields on the Setup Ethernet screen, refer to Understanding the Ethernet Settings on page 104.

Setting Up a Static IP Address

While DHCP (Dynamic Host Configuration Protocol) is the default network configuration for the BaseStation 3200 network connection, some situations, such as private network configurations or network security issues might require that you configure a static IP address for your controller.

1. Connect and configure the communication module. Check the status lights and indicators on your communication equipment to ensure that it is powered up and appears to be sending and receiving data.
2. Turn the dial to the **Network** position.
3. Press the **Next** button to select the **Ethernet Setup** option, and then press **Enter**. The Ethernet screen displays.

- In the **IP Address Mode** field, press the + or – button to change the value to **Static IP**.

Note: Ask your network administrator for the settings. For a definition of the fields on the Ethernet screen, refer to Understanding the Ethernet Settings on page 104.

- Press the **Next** button to select the first digits in the **IP Addr** field.
 - Press the **Previous** or **Next** button to move to the digits that you want to change.
 - Press the + or – button to change the value in the field.

Note: To rapidly increase or decrease the value, press and hold the + button or the – button.

- Press the **Next** button to move to the other fields that you need to change. Use the procedure described in step 5 to move within the digits and change the values.
- To view the status of your network connection, turn the dial to the **RUN** position, and view the status in the **BaseMgr** field.

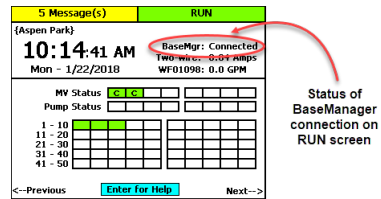
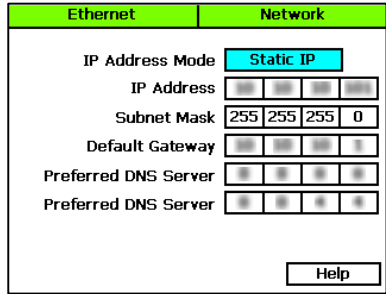

Understanding the Ethernet Settings

When your controller is connected to a network with a supported communication module, the system automatically assigns the networking addresses that enable the connection. You might need to refer to this information in order to complete your connection or to troubleshoot it.

- Connect and configure the communication module. Check the status lights and indicators on your communication equipment to ensure that it is powered up and appears to be sending and receiving data.
- Turn the dial to the **Network** position.
- Press the **Next** button to select the **Ethernet Setup** option, and then press **Enter**. The Ethernet screen displays the following information:
 - DHCP** (Dynamic Host Configuration Protocol) – The default network configuration for the BaseStation 3200. This protocol allows your controller to automatically obtain an IP address which enables the connection to the Internet. Every time you restart your controller, it retrieves a new IP address.
 - Static IP** – An IP address that is permanently assigned

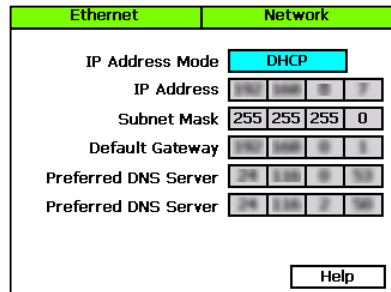

- **IP Address** – An Internet Protocol address (IP address) is a number assigned to a device (such as the controller) that is connected to a computer network and uses the Internet Protocol to communicate on the network.
- **Subnet Mask** – The subnet mask is used with an IP address to indicate what network traffic should be permitted or denied.
- **Default Gateway** – An IP address that enables the network traffic from your controller to pass through to a larger network
- **Preferred DNS Server 1** – A naming system (Domain Name System) for devices, such as your controller, that are connected to the Internet
- **Preferred DNS Server 2** – An additional domain name that is assigned to your controller

Enabling a Cell Modem Connection

If you have a cell modem installed and connected to the BaseStation 3200 controller, the Cellular Modem Setup option on the Advanced menu shows the status of the connection.

Refer to the Baseline 3G Cell Modem Installation and User Guide. You should have received a copy of this document with your equipment, but you can also find it on the Baseline website (www.baselinesystems.com).

Connecting to a FlowStation or SubStation

Baseline's FlowStation is a powerful shared flow controller that allows multiple BaseStation 3200 controllers to share water resources, including master valves, pumps, and flow meters.

Baseline's SubStation™ is a wireless extension of a BaseStation 3200™ irrigation controller that allows the controller to remotely operate devices in the field.

Both the SubStation and FlowStation communicate to the BaseStation 3200 using a local area network (LAN) or a cloud-based connection.

The LAN option utilizes a local area network at the site, or one can be created using a Cell Modem Gateway with Ethernet Radios. In this configuration all communication between a BaseStation 3200 and SubStation or FlowStation remains local to the site.

The cloud-based option utilizes the cloud to allow the BaseStation 3200 and the SubStation to pass information to one another. This configuration can be supported using a local area network or it can be set up using cellular modems connected to the BaseStation 3200 and to each SubStation or FlowStation.

The BaseStation 3200 can support a SubStation or Flow Station using the LAN while simultaneously supporting an additional SubStation using the cloud.

The BaseStation 3200 has 8 available addresses for TCP/IP-based performance components. Each SubStation or FlowStation connection uses one of these addresses. The connections can be a combination of wired Ethernet, Wi-Fi, Cell Modem and Ethernet radios.

Each BaseStation 3200 is assigned to a FlowStation or SubStation from the controller interface or from AppManager by programming the IP address of the FlowStation or SubStation into the controller.

For more information, visit the Baseline website at www.baselinesystems.com to download a copy of the SubStation User Manual or the Flow Station User Manual.

Connecting to a Munro Pump Station

A BaseStation 3200 irrigation controller can communicate with as many as 8 Munro pump stations over a network. The connections can be a combination of wired Ethernet, cell modem, and Ethernet radios.

When the BaseStation 3200 irrigation controller is connected to the pump stations, the irrigation controller gathers and logs data from the pump stations. The irrigation controller also reports any active fault that occurs on the pump stations.

The BaseStation 3200 has 8 available addresses for TCP/IP-based performance components. Each Pump Station connection uses one of these addresses. Baseline's SubStation and FlowStation also use these addresses.

For more information, visit the Baseline website at www.baselinesystems.com to download a copy of the following document:

Connecting a BaseStation 3200 Irrigation Controller to a Munro Pump Station

10 – Reports, Messages, & Logs

The main screen shows basic information about the operating state of the BaseStation controller, but additional reports and messages are available from the Reports dial position and the Messages dial position. The controller provides the following categories of reports and each category can have multiple reports.

- Zone Status
- Test All
- Moisture Sensor Data
- Water Times
- Water Used and Flow
- Operator Messages

Some reports, messages, and alerts are only available when specific conditions cause them to be generated. For example, if the main screen indicates that a pause condition has occurred, you can access the Pause message by turning the dial to the Messages position.

Zone Status

When the controller dial is in the **RUN** position, the main screen displays the **Zone Status** report.

The screenshot shows the Zone Status screen with the following callouts:

- Messages are indicated here.** (Points to the top left corner showing '2 Message(s)')
- BUSY displays to indicate that the controller is performing watering calculations and communicating with devices.** (Points to the top right corner showing 'RUN')
- The controller's current state** (Points to the 'RUN' indicator)
- Indicates the status of the BaseManager connection.** (Points to 'BaseMgr: Connected')
- Indicates the status of the two-wire.** (Points to 'Two-wire: 0.14 Amps')
- Indicates the total flow measured by the reporting device.** (Points to 'QW0268: 0.00 GPM')
- The controller's time and date** (Points to '11:45:02 AM Thu - 12/18/2014')
- Status overview of master valves and programs in groups of 50 zones.** (Points to the 'Pump/MV Status' table)
- Press the Enter button to display the online help.** (Points to the 'ENTR For Help' button)

The 'Pump/MV Status' table shows a grid of 50 zones (1-50) with columns for status indicators (blue, green, yellow, red).

When “BUSY” displays on the top line, the dial and buttons are locked out and will not work for a time. The busy time can be several seconds, depending on the number of devices on the two-wire and the number of calculations being done.

Next to the time and date, you see the status or state of the following items:

- **BaseMgr** – Indicates the status of the controller’s connection to BaseManager.
- **Two-wire** – Indicates the approximate current being supplied to the two-wire path. The value will vary with the size of the installation and the number of active valves.
- **Flow Device** – If there is no flow meter installed, the controller shows the estimated flow (in brackets) based on the flow values that have been set for each zone. With one or more flow meters, the controller indicates the total flow measured. This value is updated once each minute, and is shown without brackets. More detail is available on the Water Used report.
- **Pump/MV Status** – Shows the status of each master valve.
- **Zone Status** – The lower section shows the current status of the zones in groups of 50 zones. Press the + or – button to move between the groups 50 zones.

Detailed Status by Program

Press the **Next** or **Previous** button on the main screen to display the detailed status by program.

Press the + or – button to cycle through the controller’s programs.

Press the **Next** or **Previous** button to return to the main screen.

The colored box on the left indicates the program status. Refer to the Status Colors topic for an explanation of the colors.

The following information is available in the fields:

5 Message(s)	RUN
{Aspen Park}	
12:30:14 PM	BaseMgr: Connected
Mon - 1/22/2018	Two-wire: 0.84 Amps
	WFD1098: 0.0 GPM
■	Program 1: {10 o'clock program}
	Last Start: 01/22/18 10:00 - Schedule
	Last Pause:
	Last Stop: 01/22/18 10:13 - Schedule
	Next Start: 01/23/18 10:00 - Schedule
	Avg Time: 0:13 (last three)
	Avg Water: 0.0 gallons (last three)
<--Previous	Enter for Help
	Next-->

Last Start: The date and time when the program was started for any condition including manual starts.

Last Pause: The date and time of the most recent pause. The pause information only shows while the pause is active; otherwise, the field is blank.

Last Stop: The date and time when the program last completed watering. When a program is watering, this field is blank.











Next Start: The estimated next start date and time for the program. In some cases, the start condition for a program makes it difficult to accurately estimate when the next start will occur. Consider the information in this field as helpful, but remember that it might not be perfectly accurate depending on the program settings.

Avg Time: An average of the last 3 runtimes.

Avg Water: An average of the amount of water used during the last 3 runtimes.

Status Colors

The following colors display on the RUN screen to indicate the status of programs, master valves, flow meters, and zones.

	Idle (watering done)		Disabled
	Active (watering)		Paused
	Waiting to water		Error, Over Budget, Flow/Pressure Faults
	Soaking		Unassigned
	Learn Flow		Off, Rain Delay, Rain jumper activated

Test All Report

The Test All report displays when you turn the dial to the Reports position. This report shows the status of all devices that are connected to your controller.

To scroll through the report, press the **Next** button so **Scroll** is highlighted, and then press the + button.

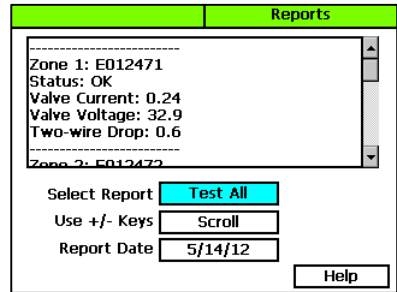

Moisture Sensor Data

The Soil Moisture Sensor Data report shows a moisture graph for each of the moisture sensors connected to the controller.

- Turn the dial to the **Reports** position.
- In the **Select Report** field, press the + button until **Moisture** displays in the box.
- Perform any of the following options:
 - To view the report for a different sensor, press the **Next** button to select the soil moisture sensor serial number, and then press the + or – button.
 - To view the report for a different date, press the **Next** button to select the **Report Date** field, and then press the + or – button.

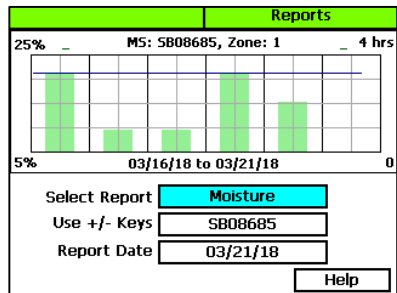

Program Run Time Report

Each program has a run time report.

Above the graph, you will see the program number that the report is generated for. Below the graph, you will see the date range for the report.

1. Turn the dial to the **Reports** position.
2. In the **Select Report** field, press the + button until **Run Time** displays in the box. The report displays for Program 1.
3. Perform any of the following options:
 - To view the report for a different program, press the **Next** button to select the program number field, and then press the + or – button to change the program number.
 - To view the report for a different date, press the **Next** button to select the Report Date field, and then press the – button to change the date.

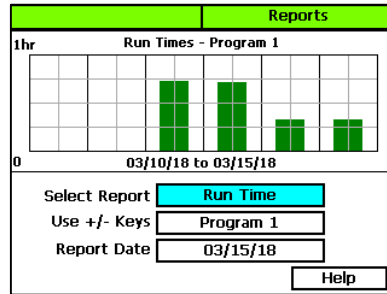

Water Used Report

1. Turn the dial to the **Reports** position.
2. In the **Select Report** field, press the + button until **Water Used** displays in the box. If you have flow sensors and/or flow meters installed, the report displays for one of those devices.
3. Perform any of the following options:
 - To view the report for a different flow sensor/meter, press the **Next** button to move to the next field, and then press the + or – button to change the low sensor/meter serial number.
 - To view the report for a different date, press the **Next** button to select the **Report Date** field, and then press the – button to change the date.

Pressure Report

1. Turn the dial to the **Reports** position.
2. In the **Select Report** field, press the + button until **Pressure** displays in the box. If you have pressure sensors installed, the report displays for pressure sensor 1.
3. Perform any of the following options:
 - To view the report for a different pressure sensor, press the **Next** button to move to the next field, and then press the + or – button to change the pressure sensor number.
 - To view the report for a different date, press the **Next** button to select the **Report Date** field, and then press the – button to change the date.

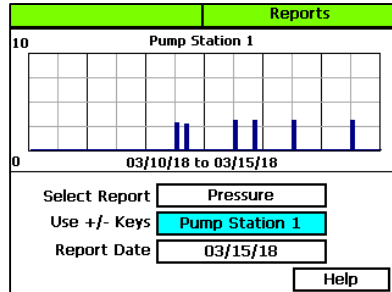

Pump Station Status

1. Turn the dial to the **Reports** position.
2. In the **Select Report** field, press the + button until **Pump Station Status** displays in the box. If you have pump stations installed, the report displays for pump station 1.
3. Perform any of the following options:
 - To view the report for a different pump station, press the **Next** button to move to the next field, and then press the + or – button to change the pump station number.
 - To view the report for a different date, press the **Next** button to select the **Report Date** field, and then press the – button to change the date.

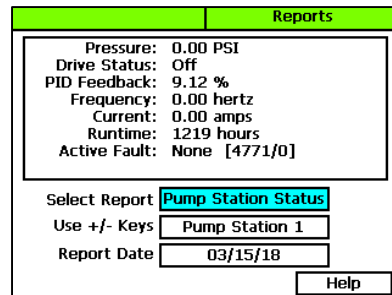

Operator Messages

Operator messages are used to indicate programming errors and to provide assistance in fixing common installation and operation problems. Messages can include status or warning messages, or serious controller alarms. The message shows the time and date of the alert. The message also includes suggestions for correcting the issue.

Messages related to shutdown conditions are not automatically cleared when the condition is eliminated.

If the message is not cleared, the affected items will return to a shutdown state.

To display the messages

1. When the main screen indicates that messages exist, turn the dial to the **Messages** position.
2. If there are multiple messages, press the + or – button while the **Alarm Message** field is highlighted to scroll through the messages.
3. To clear the message, press the **Next** button to select the **Delete** field, and then press the **Enter** button.

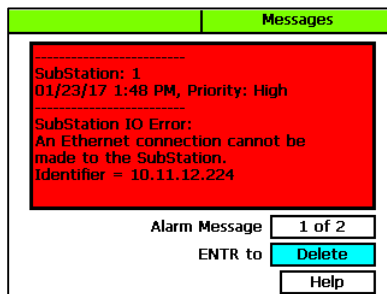

The background color of the message pane represents the priority of the message:

Red	=	High
Orange	=	Medium
Yellow	=	Low

Pause and Shutdown Messages

A variety of conditions will cause the controller to pause or shut down watering, either by specific devices, programs, or the entire controller. When one or more pause or shutdown conditions occur, the messages describe the reasons for the conditions.

The following pause and shutdown conditions can occur on the BaseStation 3200.

- | | |
|--------------|--|
| Event Date | <ul style="list-style-type: none"> • An event date stops watering and keeps programs from starting. • To clear the message, press Next to move to the Delete option, and then press Enter. • Automatically cleared when the event date ends. |
| Flow Devices | <ul style="list-style-type: none"> • Any of the following flow conditions will stop the system from using the specific flow device: <ul style="list-style-type: none"> ▪ High flow ▪ High or low flow variance ▪ Unexpected flow ▪ Over budget • To clear the message, press Next to move to the Delete option, and then press Enter. • Clearing the message does not clear a flow condition. Change the settings, fix leaks, or in the case of an over-budget shutdown, wait until the budget resets at the beginning of the next month. |

	<ul style="list-style-type: none">• Not automatically cleared – the user must clear this shutdown condition.
Flow Switch	<ul style="list-style-type: none">• An open jumper or flow switch stops all watering and keeps all programs from starting.• To clear the message, press Next to move to the Delete option, and then press Enter.• Clearing the message does not reset this condition. Replace the jumper or reset the flow switch hardware.• Not automatically cleared – the user must clear this pause condition.
Pressure Sensor	<ul style="list-style-type: none">• A high-pressure or low-pressure shutdown stops the system from using the specific control point.• To clear the message, press Next to move to the Delete option, and then press Enter.• Clearing the message does not clear a high- or low-pressure condition. Change the pressure settings or wait until the pressure increases or decreases.• Not automatically cleared – the user must clear this shutdown condition.
Low Temperature	<ul style="list-style-type: none">• When the temperature drops below 38° F, the system will pause all watering.• To clear the message, press Next to move to the Delete option, and then press Enter.• Clearing the message does not reset this condition. You must wait until the temperature rises.• Automatically cleared with higher temperatures.
Pause biCoder	<ul style="list-style-type: none">• A pause biCoder will pause watering on specific programs.• To clear the message, press Next to move to the Delete option, and then press Enter.• Clearing the message resets the pause condition before the delay time has elapsed.• Automatically cleared at end of the delay time.
Pause Switch	<ul style="list-style-type: none">• An open jumper or wired switch pauses all watering on the controller.• To clear the message, press Next to move to the Delete option, and then press Enter.• Clearing the message does not reset the pause condition until the jumper or switch has closed the circuit. Then when you delete the

message, the controller resets the pause condition before the delay time has elapsed.

- Automatically cleared at end of the delay time.

Rain Switch

- An open jumper or wired rain sensor that is wet (open) stops all watering and keeps all programs from starting.
- To clear the message, press **Next** to move to the **Delete** option, and then press **Enter**.
- Clearing the message does not reset the pause condition until the jumper or rain sensor has closed (dried out).
- Automatically cleared when the switch or rain sensor closes.

Rain/OFF days

- Setting a rain/off value for the number of days stops all watering for that period of time.
- To clear the message, press **Next** to move to the **Delete** option, and then press **Enter**.
- Clearing the message resets the delay days to zero and clears the pause condition.
- Automatically cleared when delay days are over.

Water Window

- A water window (white squares) will pause a program.
- To clear the message, press **Next** to move to the **Delete** option, and then press **Enter**.
- Clearing the message does not reset the water window pause condition – you must wait or change the water window programming.
- Automatically cleared when the water window expires (time advances to a blue square).

11 – Troubleshooting

The BaseStation 3200 has built-in features for testing zones, valves, biCoders and biSensors. These tests help you isolate and identify components and devices that are not working properly so you know what needs to be repaired.

Testing a Specific Two-Wire Device

When you test a two-wire device, the controller verifies the communication between the controller and the device. The controller activates the device and measures the current and voltage. It deactivates the device, and measures the voltage drop between the controller and the device.

1. Turn the dial to the **Self Test** position.
2. Press the **Next** or **Previous** button to select **Test Single Two-wire Device**, and then press the **Enter** button.
3. In the **Device to Test** column, press the + or – button to select the device that you want to test.
4. Press the **Enter** button to test the device.

The device will activate for less than a second to measure the voltage and current through the device. This test will return information related to the type of device that was tested.

5. When you have finished viewing the test results, turn the dial to the **RUN** position.

Self Test	
Device to Test	Test Results
MV 1	MS 1: SB08685 01/22/18 14:18 ----- Moisture: 21.3% Soil Temperature: 71.5 Two-wire Drop: 1.8
MV 2	
MS 1	
FM 1	
FM 3	
FM 2	
{Moisture biSensor 1/SB08685}	<input type="button" value="Help"/>

Possible Statuses for Valve biCoders

Refer to the following table for possible self-test statuses along with causes and suggestions for resolving the issues.

Self-test Status	Cause/Action
Open circuit	<ul style="list-style-type: none"> • Wire connection between the valve biCoder and the valve solenoid is broken – repair wire connections. • Valve solenoid is broken – replace solenoid.

Short circuit	<ul style="list-style-type: none"> • Wire connection between the valve biCoder and the valve solenoid is shorted together – repair wire connections. • Valve solenoid is broken – replace solenoid.
No response	<ul style="list-style-type: none"> • Two-wire connection to the valve biCoder is broken – repair wire and connections to the valve biCoder. • Two-wire voltage loss is too high – check other devices in same vicinity for high two-wire voltage loss – repair high resistance connections between controller and devices. • Valve biCoder is damaged – remove biCoder and move it directly to the controller to test its ability to communicate.

Possible Statuses for Soil Moisture Sensors (biSensors)

Refer to the following table for possible self-test statuses along with causes and suggestions for resolving the issues.

Self-test Status	Cause/Action
No response	<ul style="list-style-type: none"> • Two-wire connection to the biSensor is broken – repair the wire and connections to the biSensor. • Two-wire voltage loss is too high – check other devices in same vicinity for high two-wire voltage loss – repair high resistance connections between the controller and devices. • The biSensor is damaged – remove the biSensor and connect it directly to the controller to test its ability to communicate.
Zero Reading	<ul style="list-style-type: none"> • The biSensor detection blade is damaged – if the soil temperature reading is valid, replace the biSensor.

If the following conditions occur in the area where the biSensor is buried, you might get unusual or inaccurate readings from the biSensor. Review these conditions along with causes and suggestions for resolving the issues.

Condition	Causes/Action
Ground is too dry with low biSensor moisture reading	<ul style="list-style-type: none"> • Not enough zone water time – increase water time to apply at least ½ inch of water • biSensor not being watered by its primary zone – change the assignment or move the biSensor to the correct location • Program start times are too infrequent – increase the program start time frequency • biSensor limit is too low – raise limit or run a biSensor calibration cycle (refer to page 63)

Ground is too dry with high biSensor moisture reading	<ul style="list-style-type: none"> • biSensor not being watered by its primary zone – change the assignment or move the biSensor to the correct location • biSensor is buried too deep – rebury the biSensor to be only 3 inches deep
Ground is too wet with high biSensor moisture reading	<ul style="list-style-type: none"> • biSensor is buried in a low area where water collects – move the biSensor from the low area • biSensor is not being watered by its primary zone – change the assignment or move the biSensor to the correct location • Program start times are too frequent – increase the interval between start times • biSensor limit is too high – lower the limit or run a biSensor calibration cycle
Ground is too wet with low biSensor moisture reading	<ul style="list-style-type: none"> • biSensor is not being watered by its primary zone – change the assignment or move the biSensor to the correct location • biSensor is buried too deep – rebury the biSensor to be only 3 inches deep

Checking and Repairing Two-Wire Device Assignments and Addresses

This process searches for and verifies communication with each of the devices on the two-wire.

Note: Baseline recommends that you back up your controller data before you run this process. Refer to Backing Up Your Controller on page 95.

The Verify and Repair ALL process does not check the valve current or biSensor readings, and it does not repair any faulty wiring or electrical connections. However, if it finds discrepancies in assignments or addressing between the controller and the devices, it will attempt to repair those discrepancies in the following order:

- Repair valve biCoder to zone number assignments
- Repair biSensor addressing
- Repair pause device addressing
- Repair air temperature sensor addressing

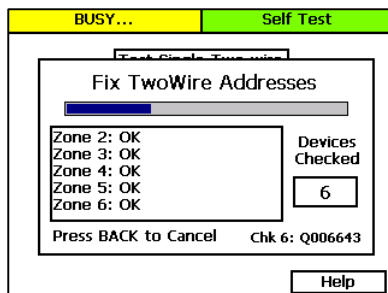

1. Turn the dial to the **Self Test** position.
2. Press the **Next** or **Previous** button to select **Check Two-wire Addresses**, and then press the **Enter** button. The two-wire tests starts immediately. While the test is in progress, the statuses and results display on the screen.

Testing All Devices

Before you begin troubleshooting a problem, run a Test ALL from the Self-Test dial position. This test checks all the devices on the two-wire and displays a summary screen of the results.

If the test finds errors with the devices, the error count is listed for each device type. The quantity of each device type is also given in parenthesis. This test verifies communication and valve currents, biSensor readings, and other device readings, but it does not make any repairs.

1. Turn the dial to the **Self Test** position.
2. Press the **Next** or **Previous** button to select **Test All Two-wire Devices**, and then press the **Enter** button. The test begins immediately.
3. When the test is finished, turn the dial to the **Reports** position.
 - a. Make sure that **Test All** displays in the **Select Report** field.
 - b. To scroll through the report, press the **Next** button to select the **Scroll** field, and then press the **+** button.

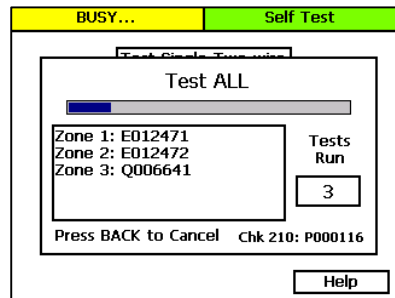

4. When you have finished viewing the test results, return the dial to the **RUN** position.

Performing a Two-wire Blink Test

Use the Two-wire Blink Test to find bad electrical connections, broken wires, or device failures. Running this test activates the two-wire path and should cause the communication LED on each device to blink. If an LED is not blinking, check the electrical connections.

Note: It is usually best to perform this test when one person is working at the controller and another person is verifying the blinking LEDs in the field.

1. Turn the dial to the **Self Test** position.
2. Press the **Next** or **Previous** button to select **Two-wire Blink Test**, and then press the **Enter** button. The Self Test screen displays.

3. In the **Blink Interval** field, press the **+** or **-** button to indicate the number of seconds between blinks.
4. Press the **Enter** button to start the test.

While the blink test is in progress, the Blink Interval field displays "Running" and the Status box displays the results.
5. To stop the test, press the **Back** button.

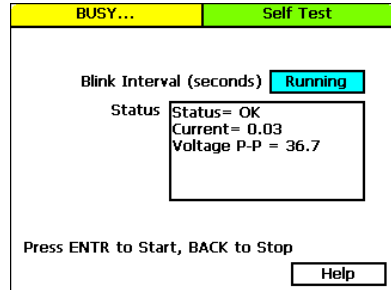

Troubleshooting the Two-Wire: High Current or Shorted

The first step in troubleshooting the two-wire is to isolate what works from what does not work. A complex system with many branches in the two-wire path can be difficult to troubleshoot while everything is interconnected. When a short can be isolated to a single segment of the two-wire system, or to a single component, it becomes much easier to fix the problem.

As you approach problem solving situations, separate problems into the following categories:

- It has never worked.
- It worked before and now it does not.

For problems that fall into the second category, find out what has changed because these factors might provide some insight or a place to start looking for solutions.

In order to isolate the short, you must physically disconnect two-wire segments and components from the system in a logical manner. Then you can add the two-wire segments and components one at a time in order to isolate the problem.

- Begin by disconnecting half of the two-wire.
- Next, determine whether the system is running properly with just half of the two-wire connected. If it is, you know that the short is in the other half of the two-wire. If the system does not run properly, you know that the problem is in the half of the two-wire that is connected.
- After you have isolated the short to a half of the two-wire, you can start breaking connections, one at a time, in order to isolate exactly where the problem is.
- After you isolate the short, you need to find out what changed recently that may have caused the problem.
 - Is there the possibility of lightning damage?
 - Any recent work done on the site that could have damaged the buried wire?
- If there is no apparent damage to the two-wire, start disconnecting devices, one at a time, from the shorted segment until the problem goes away.

- After the short has been diagnosed as either damage to the wire or a faulty device, repair or replace it.
- Reconnect components on the repaired two-wire segment. Verify that adding these components does not cause additional failures.
- Connect other two-wire segments, verifying correct operation as each is connected.

Diagnosing a Circuit Board Issue

1. Disconnect the two-wire from the controller.
2. Check the controller to determine whether the Over Current message redispays.
3. If the message redispays, you have confirmed a circuit board issue. Contact Baseline Support at 866-294-5847.

Troubleshooting with a Milliamp Clamp Meter

1. Wire a solenoid in line with the red wire of the two-wire path right after the controller as illustrated here.
2. Verify that the two-wire is set to always on. Refer to Changing the Two-Wire Always On Setting on page 94.
3. Use the milliamp clamp meter to take a milliamps ac reading on the red wire (two-wire) that is connected to the controller. Write down this reading, which will be referred to as the “over-current reading.”
4. Go to the first wire splice and use the milliamp clamp meter to take a reading on all red wires (two-wire). As you take the readings, look for a number that is close to the over-current reading.

Note: The reading does not have to be identical.

5. Continue testing all red wires on the two-wire path, looking for the over-current reading until you isolate a wire segment or device that is generating that number.
6. Remove the suspected device from the two-wire path, and then check the controller again.
7. Perform one of the following actions:
 - If the Over Current message persists, check the two-wire in that stretch for damage.
 - If the Over Current message goes away, remove the two-wire path and connect the device directly to the controller. If the Over Current message returns, the device is faulty and will need to be replaced.

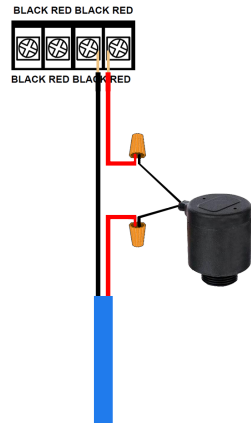

Troubleshooting Manually

If you do not have a milliamp clamp meter, you can manually break the two-wire connections in a systematic manner to isolate a wire segment or device that is generating the Over Current message.

1. Determine the approximate halfway point of the two-wire path, and then break the connection at that valve box.
2. Check the controller again. Perform one of the following actions:
 - If the Over Current message persists, the problem is in the half of the two-wire that is still connected to the controller. Find the halfway point of that segment and start at step 1 again.
 - If the Over Current message goes away, the problem is in the disconnected half of the two-wire path. Reconnect the two-wire path, and then disconnect at the halfway point of the problem section. Start at step 1 again.
3. When you have isolated the device or the stretch of two-wire where the problem seems to be originating, remove the two-wire path and connect the device directly to the controller. If the Over Current message returns, the device is faulty and will need to be replaced.

Troubleshooting: Lost Devices | No Response

Begin by walking the two-wire and checking for what has changed that may have caused the communication errors.

- Is there just one communication error or is there a group of them?
 - If there is more than one, are they all on the same wire? The same physical area?
 - If this is the case, check the connections and wiring in that area of the two-wire.
- Repeat as necessary

12 – Appendix

Warranty

Baseline warrants to the original consumer purchaser that new BaseStation 3200 Series controller as well as the 12 and 24 valve biCoders will be free from defects in material and workmanship for the Standard One Year Warranty Period. The Baseline biSensor™ as well as 1, 2 and 4 valve biCoders will be free of defects in material and workmanship for a 5-Year Warranty Period. The start of the warranty period is the date of installation of the system or component. For replacement irrigation components, the warranty on the replacement component is the remainder of the warranty on the original component, or 90 days, whichever is longer.

If you discover a defect, contact your Baseline product installer, or Baseline Inc.

Baseline will, at its option, repair or replace the component at no charge to the customer, provided it is returned during the warranty period, with transportation charges prepaid, to Baseline Inc. in Boise, Idaho. Baseline will pay return shipping of its choice. BaseStation controllers and displays must be properly packaged in the original packaging or in Baseline approved packaging to obtain warranty service.

For warranty service, contact Baseline at 1-866-294-5847 to obtain a "Return Material Authorization" (RMA) number. A copy of the receipt or a bill of sale bearing the appropriate Baseline serial number and model number may be required for warranty service. Warranty Exclusions: normal wear and tear, abuse, unreasonable use, mistreatment, or neglect. Damage caused during installation or incorrect installation, damage caused by modification or repair not made or authorized by Baseline whose Manufacturer's Serial Number and/or Material Number label have been removed, torn or defaced, damage caused by use of non-Baseline packaging, damage caused by improper or improperly used packaging.

THIS WARRANTY AND REMEDIES SET FORTH ABOVE ARE EXCLUSIVE AND IN LIEU OF ALL OTHERS, WHETHER ORAL OR WRITTEN, EXPRESSED OR IMPLIED. BASELINE SPECIFICALLY DISCLAIMS ANY AND ALL IMPLIED WARRANTIES, INCLUDING, WITHOUT LIMITATION, WARRANTIES OF MERCHANTABILITY AND FITNESS FOR A PARTICULAR LIMITATION, WARRANTIES OF MERCHANTABILITY AND FITNESS FOR A PARTICULAR PURPOSE AND AGAINST INFRINGEMENT. No Baseline dealer, agent or employee is authorized to make any modification, extension or addition to this warranty.

BASELINE IS NOT RESPONSIBLE FOR SPECIAL, INCIDENTAL, INDIRECT OR CONSEQUENTIAL DAMAGES RESULTING FROM ANY BREACH OF WARRANTY, OR UNDER ANY OTHER LEGAL THEORY, INCLUDING BUT NOT LIMITED TO LOSS OF DATA, LOSS OF PROFITS, DOWNTIME, GOODWILL, DAMAGE OR REPLACEMENT OF EQUIPMENT AND PROPERTY.

Some states do not allow the exclusion or limitation of incidental or consequential damages or exclusions of implied warranties, so the above limitations or exclusions may not apply to you. This warranty gives you specific legal rights, and you may have other rights that vary from state to state. A 5-year Extended Warranty will be available on the controller pending submission and approval of Baseline's Extended Warranty Application.

Tips for Setting Up Common Configurations

Lower Threshold Moisture Sensor Based Watering

Baseline recommends this configuration as a general watering strategy.

1. Install the soil moisture sensor in the landscaping according to the instructions that came with the device.
2. In the BaseStation 3200, search for and assign the sensor. Refer to Searching For and Assigning Devices on page 35. **Error! Bookmark not defined.**
3. Set up the soil moisture sensor and assign that sensor to the primary zone that will water it. Refer to Setting Up Soil Moisture Sensor Based Watering on page 61.
4. Assign the primary zone to a program by giving the zone a water time. Make sure the water time for the primary zone is sufficient to lay down $\frac{1}{2}$ " to $\frac{3}{4}$ " water. Refer to Configuring Zone Settings on page 37.
5. Link the other zones in the area that is monitored by the sensor to the primary zone. Refer to Linking Zones on page 45.
6. Set the **Lower Limit** watering strategy for the primary zone. Refer to the topic on configuring your biSensors and setting up watering strategies on page 61.
 - a. Set the **Lower Limit** halfway between field capacity and maximum allowed depletion so there is no stress to the plant material when a day is skipped.
7. Set up the start days and times.
 - a. Start every day if possible.
 - b. Set start time as desired.
8. Set up the **Soak Cycles** for the program. Refer to Using Soak Cycles on page 46.
 - a. Set up at least 3 cycles.
 - b. The soak time should be at least 2X the cycle time for normal soils.

Upper Threshold Moisture Sensor Based Watering

This watering strategy is particularly useful for landscapes that need to reach a desired moisture level on a regular schedule, such as sports fields or heavy use parks. On these types of properties, damage to turf takes place when the soil is either too wet or too dry.

This strategy is also useful for landscapes that are under municipal watering restrictions.

1. Install the soil moisture sensor in the landscaping according to the instructions that came with the device.
2. In the BaseStation 3200, search for and assign the sensor. Refer to Searching For and Assigning Devices on page 35.
3. Set up the soil moisture sensor and assign that sensor to the primary zone that will water it. Refer to Setting Up Soil Moisture Sensor Based Watering on page 61.

4. Assign the primary zone to a program by giving the zone a water time. Make sure the water time is sufficient to get through the longest day interval during the hottest time of the year (typically $\frac{3}{4}$ " water). Refer to Configuring Zone Settings on page 37.
5. Link the other zones in the area that is monitored by the sensor to the primary zone. Refer to Linking Zones on page 45.
6. Set up a **Day & Time** start condition for the program. Refer to Setting Up Programs on page 48.
 - a. Start on desired days.
 - b. Start at desired time.
 - The controller will run every time it is programmed.
7. Set the **Upper Limit** watering strategy for the primary zone. Refer to the topic on configuring your biSensors and setting up watering strategies on page 61.
 - a. Set the **Upper Limit** at field capacity.
8. Set up the **Soak Cycles** for the program. Refer to Using Soak Cycles on page 46.
 - a. Set up at least 3 cycles.

BL-3200 Hydrozone Worksheet

1. Record your programming information from your old irrigation controller. Use the table below to make this process easier.
2. Identify the hydrozones in your landscape. A hydrozone is a grouping of zones that can be watered similarly, such as zones that share the same slope, sun exposure, and plant type. Areas that require dissimilar water or scheduling requirements are considered to be separate hydrozones. Make up a descriptive name for each hydrozone, such as "turf," "shrub border," "perennial bed," and so on. On the worksheet, record the hydrozone for each zone.

Existing Irrigation Controller Information

Zone#	Program	Run Time	Hydrozone	Zone Description
1.				
2.				
3.				
4.				
5.				
6.				
7.				
8.				
9.				
10.				
11.				
12.				
13.				
14.				
15.				
16.				
17.				
18.				
19.				

20.				
21.				
22.				
23.				
24.				
25.				
26.				

Additional Information for Existing Programs

Program	Watering Days	Start Times

Programming Information for the BaseStation 3200 Controller

1. Use the table below to plan connections and programming before physically programming the controller.
2. Determine which zone within each hydrozone will be the “primary” zone. If you are using a biSensor, the primary zone is the zone where the sensor is located. You will set up the watering strategy for the scheduling group based on the readings from that sensor. In the BaseStation 3200 controller, you will designate this zone as the primary zone. Refer to Setting up a Primary Zone on page 44.
3. Determine how the irrigation zones for each hydrozone will be put into a scheduling group. Link the other zones in the scheduling group to the primary zone so they will be watered more or less relative to it. In the BaseStation 3200 controller, you will link the zones in the scheduling group to the primary zone. Refer to Linking Zones (Creating a Scheduling Group) on page 45.

Note: When you are connecting biSensors, wire them across the valve wires that are on terminals A-1, A-2, B-1 or B-2 because only these terminals support biSensors that are wired across valve connections. You can only connect one biSensor per terminal. If you have more than 4 biSensors, you will need to run two-wire for the additional biSensor connections.

BaseStation 3200 Advanced Irrigation Controller Manual

Connector	biCoder S/N	biSensor S/N	Zone # on BaseStation	Old Zone #	Hydrozone	Program	Run Time
A-1	VA00001						
A-2	VA00002						
A-3	VA00003						
A-4	VA00004						
A-5	VA00005						
A-6	VA00006						
A-7	VA00007						
A-8	VA00008						
A-9	VA00009						
A-10	VA000010						
A-11	VA000011						
A-12	VA000012						
B-1	VB00001						
B-2	VB00002						
B-3	VB00003						
B-4	VB00004						
B-5	VB00005						
B-6	VB00006						
B-7	VB00007						
B-8	VB00008						
B-9	VB00009						
B-10	VB000010						
B-11	VB000011						
B-12	VB000012						
E-1	VE00001						
E-2	VE00002						

Additional Information for New Programs

Program	Watering Days	Start Times

Glossary of Terms

address	When a device is connected to the two-wire, the device is given an address that identifies it to the BaseStation 3200 controller.
air temperature sensor	A sensor that functions like thermometer to measure the temperature of the air and report this measurement to the controller by way of a biCoder
application rate	The rate at which water is applied to an area within the landscape by an irrigation system. In order to determine proper duration of watering, it is essential that you know the application rate for each watering zone.
auto-calibration	The controller is able to determine the water holding capacity (field capacity) of soil when using biSensor based watering strategies. A single calibration cycle, or automatic monthly calibration cycles can be scheduled.
biCoder™	This is Baseline's term for several types of two-wire devices. A Baseline valve decoder is referred to as a valve biCoder. Baseline decoders are called biCoders because they are capable of full, bidirectional communications, which enables biCoders to report back to the controller with specific information, including valve solenoid current and voltage, two-wire communications health and voltage, and other rich diagnostics information.
biLine™ protocol	Baseline's proprietary two-way communication standard that operates over two-wire irrigation wiring
biSensor™	Baseline's patented digital Time Domain Transmission (TDT) soil moisture sensor
concurrent zones	The number of zones (valves) that can be operated at the same time – typically limited by the electrical and hydraulic capacity of the system
control point	A control point is a hydraulic component in Baseline controllers that collects data from assigned devices, and then enables the irrigation system to act on that data.
decoder	An industry term for a two-wire device that can actuate a valve when the controller sends a message to do so. Baseline decoders are called biCoders because they are capable of full, bidirectional communications.
design flow	The GPM that is expected for a zone or the capacity of a mainline, based on the physical components and topology used in construction
distribution	The precipitation rate for different areas of the landscape based on head types, spacing, layout topology, pressure, etc. Having a uniform distribution is very important.
distribution uniformity (DU)	A measure of how evenly a sprinkler system applies water to any specific zone or area. High distribution uniformity means that the measured precipitation rate at any point in a zone will be roughly the same. Low distribution uniformity means that some areas get much more water per minute of water time than others.

ET-based watering	A watering methodology that uses the principles of evapotranspiration to water when needed rather than on an established schedule
evaporation	Loss of water as vapor from the soil surface or from moisture on the surface of a leaf. Differs from transpiration in that the water does not pass through the plant parts.
evapotranspiration (ET)	The process of transferring moisture from the earth to the atmosphere by evaporation of water and transpiration from plants.
field capacity	This is the maximum water holding capacity of the soil, in other words, the level of soil moisture left in the soil after drainage of the gravitational water. Irrigation to levels above field capacity will result in runoff or drainage as gravitational water.
flow device	A device that is capable of measuring water flow and water used
GPH	The abbreviation for gallons per hour
GPM	The abbreviation for gallons per minute
hydrozone	A grouping of plants that have similar water requirements and can be watered the same
infiltration	The process by which water passes through soil – the liquid permeates the soil by passing through the pores in the soil
k-value	(also known as k-factor) A calibration factor for a flow device expressed in pulses per unit volume. The k-value is used to calibrate the volumetric throughput of a flow device. Manufacturers give the k-value (or k-factor) of their flow device in the device specification.
linked zone	Within a zone group, there is one primary zone and all other zones are then “linked” to the primary and will get their programming information from the primary (water time, program, schedule, etc.)
lower limit (lower threshold)	This water strategy is programmed by setting the schedule to water every day and then setting the biSensor to allow watering when the moisture level drops below this limit – the controller can automatically set this lower limit after a calibration cycle, or it can be set manually.
mainline	The mainline is the section of pressurized pipe from the control point to the valve that operates water flow to a zone.
master valve (MV)	An automatic or manual valve installed on the mainline piping
maximum allowed depletion (MAD)	When the soil moisture content reaches this level, irrigation needs to start. In most cases, the maximum allowed depletion level is just before the plants begin to show visible signs of stress.
microclimate	The climate of a specific location within a landscape. Variations in climate are influenced by subtle differences in temperature, humidity, and wind exposure. Microclimates can have a significant impact on plant water needs.

NCMV	Normally closed master valve
NOMV	Normally open master valve – It can monitor high flow and shut down independently from the controller.
offset value	A calibration factor for a flow device that compensates for limitations in the device’s ability to measure small signals adequately. Manufacturers give the maximum amount of offset associated with their flow device in the device specification.
permanent wilting point	When soil moisture content reaches this level, plants can no longer get water from the soil, and they will wilt and die
powered decoder	A decoder device that interprets the signals that it receives from the controller and tells the valve to turn on or off. A powered decoder is designed to retrofit into existing systems and requires 120 VAC service at installation location.
primary zone	The zone within a scheduling group that all other linked zones are linked to. Changing the programming on this zone will adjust the programming on all linked zones, resulting in saved time and consistency. If you are using a biSensor, the primary zone is the zone that the sensor is connected to.
program	A program is a controller schedule used to organize watering events. Each program can have different start times, water days, water windows, and watering strategies.
pump start	A relay or relay-type device that initiates turn on of a pump, typically a high horsepower electrical or motor driven pump.
runoff	When the soil moisture content is at the saturation level, any excess water from rain, snow melt, or irrigation drains to a low point in the landscape
saturation	When the soil moisture content is at this level, nearly all of the spaces between soil particles are filled with water. After a soil has reached saturation, it does not become more saturated; although, in some situations where water is trapped, it can become flooded.

scheduling group	A group of one or more zones that have been linked together for irrigation scheduling. A scheduling group must have one primary zone, and may have one or more linked zones. Irrigation for all zones in a scheduling group will follow the watering strategy of the primary zone, but actual water times and soak/cycle behavior will scale as programmed relative to the primary zone.
soak cycle	When a zone waters using soak cycles, the total water time includes periods of watering interspersed with periods of non-watering times (soak times).
soil-moisture content	The ratio of the volume of contained water in a soil compared with the entire soil volume
soil-moisture deficit	When soil dries (for example, by evaporation), the measurable shortage of water in the soil is known as the soil-moisture deficit. It also refers to the amount of water needed to return to field-capacity moisture content.
time domain transmission (TDT)	A measurement of how much the electrical signals in the soil are slowed down by the presence of water
timed zone	Any zone programmed to water on a time/day schedule, rather than on a smart irrigation schedule
transpiration	The loss of water vapor from parts of plants. Water is lost primarily from the pores on the leaves but also from stems, flowers, and roots
two-wire	This site wiring technique consists of a cable with an outer insulation, around 2 internal insulated wires, being used to provide communication and power for all valves and other devices throughout the site. It provides full two-way communication much like a computer network.
upper limit (upper threshold)	This water strategy varies the zone water time each time the program runs in order to apply enough water to raise the moisture level to field capacity.
valve	A device that opens to allow water to flow to the sprinkler heads or emitters in a zone. It closes to halt watering for that zone.
water budget	In the BaseStation 3200 controller, the water budget functionality enables you to define and track the total flow for each Flow biCoder per month. You can configure the target flow value in GPM for the Flow biCoder and how the system will react when this number is reached.
water source	A water source specifies where water is coming from.
water window	The time available for watering through an irrigation system. Typically, all days and times would be available for watering unless there are watering restrictions or you need to set aside a time for mowing.
zone	A designated area of landscaping that is watered by a specific valve