

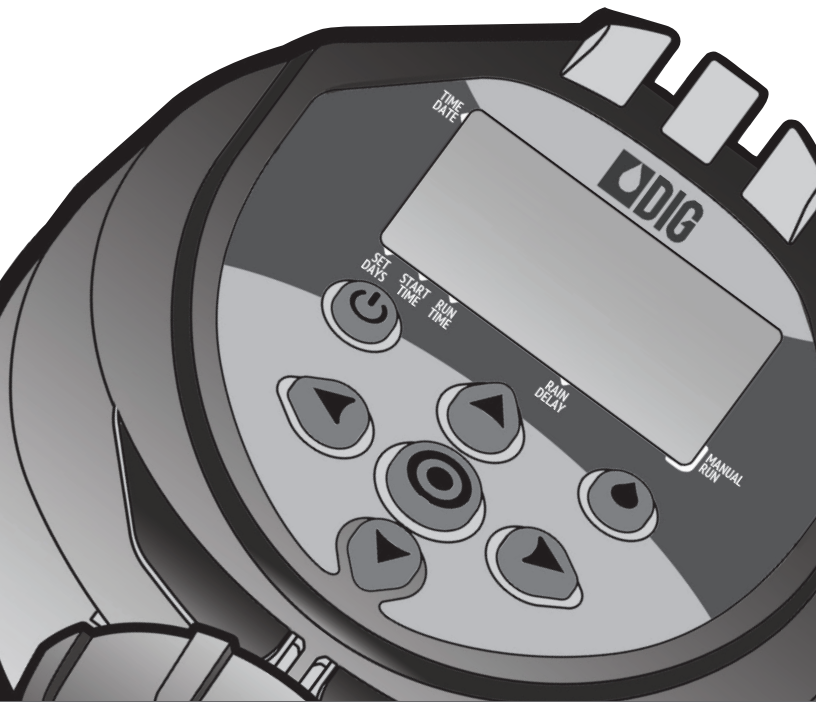

Battery Powered
Anti-Siphon Valve
Irrigation Controller
400A



I N S T R U C T I O N M A N U A L

TABLE OF CONTENTS

1. Introduction.....	1
2. About the 400A Irrigation Controller	1
3. Component identification	1
4. LCD display and controls	2
5. Installing the batteries	3
6. Anti-siphon valve installation	4
7. Programming	5
8. Setting current time and date	5
9. Setting watering day schedules	7
10. Setting watering start times.....	11
11. Setting watering run times (program(s) duration)	12
12. Setting rain delay – optional feature	14
13. Manual watering	15
14. Connecting a rain sensor	17
15. Changing the batteries	18
16. Maintenance, troubleshooting and repairs.....	19
17. Warranty	21
18. Technical assistance	22
19. To order replacement or spare parts.....	23

1. INTRODUCTION

Thank you for purchasing DIG's 400A Single Station Battery Operated Controller. This manual describes how to get the 400A series up and running quickly. After reading this manual and becoming familiar with the basic functionality of the controller, use the manual as a reference for less common tasks in the future.

2. ABOUT THE 400A BATTERY OPERATED CONTROLLER

The 400A irrigation controller employs the latest irrigation programming features to allow for complete control of any irrigation system. The 400A is available in a single station model which includes a 3/4 in. anti-siphon valve, with a rain sensor connection, and is powered by two AA batteries that can last up to 3 years [using name brand alkaline batteries]. The controller is enclosed in a compact, waterproof housing to protect it from the elements.

3. COMPONENT IDENTIFICATION

1. Controller cover
2. Quick reference label
3. LCD Display displays the icon-based applications/ programs
4. 7 button programming keypad: Use for programming, system on/off, manual run and reviewing program
5. Battery compartment cap for two AA alkaline batteries (not included)
6. Rain sensor yellow wire connection
7. Collapsible 36 in. solenoid wire
8. DC solenoid
9. Anti-siphon air vent
10. 3/4 in. pipe thread outlet (FNPT)
11. Manual flow control
12. External bleed screw
13. 3/4 in. pipe thread inlet (FNPT)
14. Anti-siphon valve

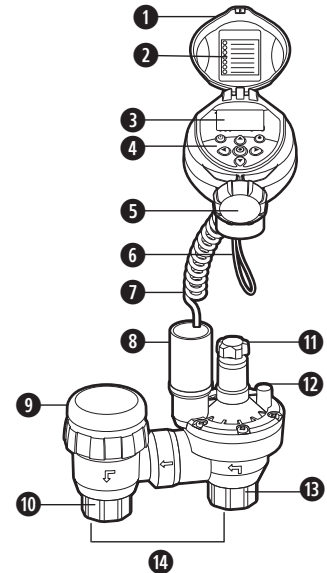



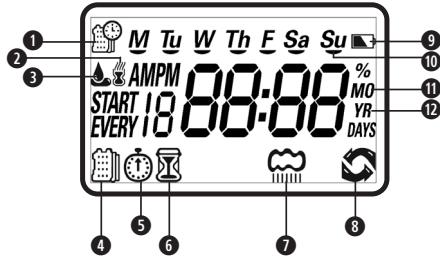

4. LCD DISPLAY AND CONTROLS



LCD Display

1. **Time and Date Icon** – Indicates current time and day is displayed
2. **Sensor Icon** – Appears when a rain sensor is active or when yellow wire loop has been cut and watering is halted
3. **Watering Icon** – Appears when valve is open
4. **Set Watering Days Icon** – Choose either specific days, odd/even days, every X hours, or up to once every 30 days
5. **Start Time Icon** – Up to 4 start times per day available
6. **Run Time Icon** – Watering duration from 1 minute to 5 hours and 59 minutes
7. **Rain Delay Icon** – Delay irrigation setting from 1 to 99 days with automatic restart
8. **Manual Run Icon** – Appears when manual button is pushed
9. **Battery Level Indicator** – Flashes when batteries are low and need to be replaced
10. **Day of the Week Underscore** – Shows which day of the week the timer will operate
11. **Represents Month**
12. **Represents Year**

Control Buttons

-  Select programming mode
-  Turn ON/OFF program
-  Start/stop a manual cycle
-  Move left/right to select a value
-  Raise/lower the selected value

5. INSTALLING THE BATTERIES

1. Open the battery compartment cap by turning it counter-clockwise.
2. Install two, fresh, brand name, AA alkaline batteries (not included) and note the proper direction of the positive and negative orientation on the underside of the timer.
3. Insert and screw the battery cap clockwise. Make sure to securely tighten the cover firmly by hand only. The timer display appears with a day, PM, and the hour digit flashing. The controller is ready to be installed and programmed.

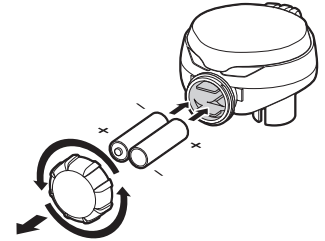

6. ANTI-SIPHON VALVE INSTALLATION

The 400A can be installed directly to PVC pipe with two PVC male adapters (not included). Inlet 3/4 in. FNPT, outlet 3/4 in. FNPT.

Rated operating pressure: 10 to 125 PSI

Recommended operating pressure: 10 to 80 PSI





NOTE: The 400A must be installed at least 6 in. higher than the highest sprinkler head on the system or back-drainage may occur. Additional control valves must not be installed downstream of the anti-siphon valve. The valve must not be operated continuously for more than 12 hours in any 24-hour period.

Consult local codes for specific details.

1. Flush main line until water runs clear before installation.
2. Shut off main water supply.
3. Install the anti-siphon valve directly to PVC pipe using 3/4 in. PVC male adapters (Figure A1 and A2) or use 3/4 in. schedule 80 nipple. The arrow on valve body indicates direction of water flow.

NOTE: Wrap all fittings with Teflon tape. Do not use pipe cement on the valve as this will damage the valve and void the warranty.

Make sure when wrapping fittings with Teflon tape that no excess gets into the internal assembly. Tighten the fittings with a wrench, but do not over tighten.

4. Turn the main water supply on and pressurize the system.
5. To test the 400A, press the  button. A click will be heard, indicating the valve is open. A droplet icon  on the upper left of the screen and the run time remaining will appear on the display in 5 seconds. Check that the system is operating correctly and press the button again to turn it off. A second click will be heard indicating that the valve closed. The droplet icon  and the manual icon  will disappear from the display and OFF will appear momentarily; then the display will revert to the time of day.
6. The unit is now ready to be programmed.

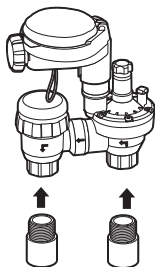

Figure A1

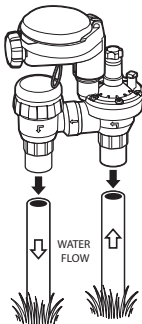





Figure A2

7. PROGRAMMING

The 400A controller can be programmed to operate on any day(s) of the week, odd days or even days. In cyclical mode the 400A can also operate from every 1 hour up to every 12 hours or from once a day up to every 30 days. The 400A has four start times per day and durations from 1 minute up to 5 hours and 59 minutes.

This section explains the programming features, and the steps necessary to assign irrigation schedules. To program the timer use the  to select the desired programming mode, the  to make the entry flash and the   buttons to change the value.



NOTE: Only a flashing value can be changed.

NOTE: If the last data entered stops flashing, press  again to resume programming and repeat the steps.

8. SETTING CURRENT TIME AND DATE

The timer can display the time in either a 12 or 24 hour format.



To change the time format, from the home screen:

1. Press the  button for three seconds until the  display switches format (AM/PM disappears).



SETTING THE CURRENT TIME AND DATE

To enable the timer to operate properly, the current time and date must be set.

1. Press the  button, until the  icon appears along with the time and the day of the week.



- If the current time has not been set or needs to be updated press and the hour digit starts flashing.
- To set the current hour, press or (note AM and PM designations).
- To set the minutes, press again and the minute digit starts flashing. Press the or to set the current time in minutes.



- Repeat the steps to set the current date including, month, day and year. When the date is selected and updated, the day of the week will be update at the same time to correspond with the date.

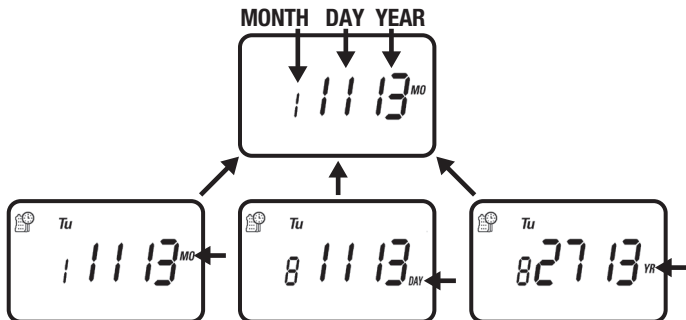

Press to move backward. Press , to proceed to the next step,

SET DAYS or to review the program.

9. SETTING WATERING DAY SCHEDULES

Option 1 – Setting Specific Days of the Week:

This setting determines which days the 400A controller will operate. Choose either watering on specific days of the week, EVEN/ODD days or cyclical from daily up to once every 30 days. The timer's default setting is to water on all specific days of the week.

For example, if you want to water every Tuesday, Thursday and Sunday:

- Press the button until the icon and the days of the week appear on the screen.

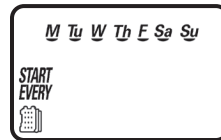

- Press once and **M** (for Monday) starts flashing.
- Press, and underscore under **M** (Monday) disappears. Monday is de-selected.
- Press twice and **W** (for Wednesday) starts flashing.
- Press and the underscore under **W** (Wednesday) disappears. Wednesday is de-selected.
- Press twice and **F** (Friday) starts flashing.
- Press and the underscore under **F** (Friday) disappears. Friday is de-selected.

- Press and the underscore under **Sa** (Saturday) starts flashing.
- Press and the underscore under **Sa** disappears. Saturday is de-selected.

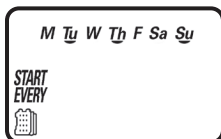

- Press the button to proceed to the next step START TIME or to review the program.

Option 2 – Setting Even or Odd Days:

To select **EVEN** days, **ODD** days refer to the example.

Example: setting the timer to water on ODD days

- Press the button until the icon and the days of the week appear.
- Press and to skip all the days of the week (underscore must be removed beneath all days).
- Press and EVEN appears flashing.



- Press and ODD appears flashing.



- Press the button to proceed to the next step START TIME or to review the program.

Option 3 – Setting every X hours:

Example: setting the timer to water every 7 hours









- Press the button until the icon and the days of the week appear.
- Press and to skip all the days of the week (underscore must be removed beneath all days).
- Press and EVEN appears flashing.
- Press again and 1:00 hour appears flashing. To select the number of hours between watering to 7 hours, press until 7:00 appears on the display.



- Press the button to proceed to the next step START TIME or to review the program.



Option 4 – Setting every X days:

Example: setting the timer to water every 10 days:

1. Press the  button until the  icon and the days of the week appear.
2. Press  and  to skip all the days of the week (underscore must be removed beneath all days).
3. Press  and EVEN appears flashing.
4. Press  again and 1 hour appears flashing.
5. Press  again and 1 DAY appears flashing. To select the number of days between watering to 10 days, press  until 10 appears on the display.



To set the timer back to specific days mode:

1. Push the  button until – *START EVERY* and the  icon appear at the bottom left of the screen.
2. Push the  until the days of the week appear at the top of the screen.

Press the  button to proceed to the next step START TIME  or to review the program.







10. SETTING WATERING START TIMES

The 400A controller can have up to four separate irrigation start times per day. (Note: if the timer is set to water every X hours, only one start time is available to be programmed.)

To set a start time,

1. Press the  button until the  icon appears. START 1, displays OFF or the last start time programmed in START 1 appears.



2. Press  and OFF (or the first start time programmed) begins flashing.
3. To set the desired first start time hour (note AM and PM designations), press  or .
4. Press  and the minutes start flashing.
5. Press  or  and set the desired start time minutes.

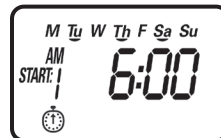

6. Press  again, the second start time and OFF or the last start time programmed appear flashing. Repeat the steps to set the second, third, and if needed, the fourth start time. During programming, if you are set to water on specific days of the week, the screen also shows which days the timer will operate with an underline.

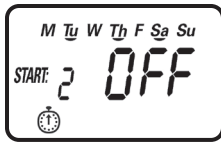

To delete a start time:

1. Press until START 1 appears.
2. Press until the start time appears that you want to delete.
3. Press until the word OFF appears.

Press the to proceed to the next step RUN TIME or to review the program.

11. SETTING WATERING RUN TIMES (DURATION)

This setting determines the length of time the 400A controller will allow the valve to remain open (duration is from 1 minute up to 5 hours and 59 minutes). For example, setting watering run time to 10 minutes on certain days of the week will program the controller to turn the water on for 10 minutes on each of the days chosen and at every start time selected. (Note: if the timer is set to water every X hours, the maximum duration is 59 minutes)

To set the watering run time :

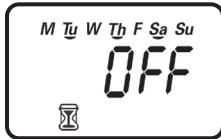

1. Press the button until the icon appears and OFF or the last run time setting appears. (OFF will appear if duration is set to 0)
2. Press the button, and 0:00 (or the last run time programmed) appears with hours flashing.

3. To set a desired watering run time in hours, press or and select the number of hours.

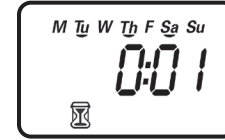

4. If only watering duration in minutes is required, press to skip the hour digit, and the minutes will start flashing.

5. To set the desired watering duration in minutes (example of 10 minutes), press or to select minutes. When programming the watering duration, if you are set to water on specific days of the week, the screen will also show the days the timer will operate with an underline.

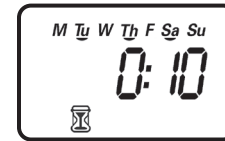

At this point the controller's normal programming is concluded.

Press the button to proceed to the next step RAIN DELAY or to review the program or to exit.

12. SETTING RAIN DELAY – OPTIONAL FEATURE



The Rain Delay setting is used to temporarily suspend all irrigation for a defined number of days. For example, during rainy weather regularly scheduled programs can be turned off from 1-99 days. At the end of the designated period, regularly scheduled programming will resume automatically.

To set a temporary suspension of the program:



1. Press the  button until the  icon and OFF appear.



2. Press the  button and OFF starts flashing.

3. To set the desired temporary suspension of the program (1-99 days), press  or .







4. The temporary suspension of the program can be cancelled at any time by re-entering Rain Delay screen and changing the setting to OFF. (Press  or  until OFF appears.)

Note: OFF appears in between numeric value of 99 and 1. Press the  button to review the program or to exit.

13. MANUAL WATERING

The manual mode allows the user to test the system and water for a specified run time set in watering duration. The timer will automatically stop watering at the end of the defined irrigation period. The originally programmed irrigation schedule continues to function at the times assigned. The sensor condition is disregarded in this mode.

To start a manual run,

1. Press the  button, and the  icon and  icon appears. ON appears momentarily and then the last watering duration is displayed with  . The timer will open the valve and in 5 seconds a count down of the remaining irrigation duration appears, showing when the timer will close the valve.

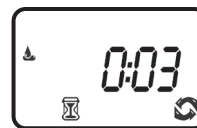

2. Press the  button to end manual run.
3. After 5 seconds the display will revert to the current time screen.

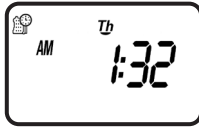

To activate a manual watering without the use of the timer – turn the solenoid a 1/4 turn counterclockwise. To stop, tighten the solenoid clockwise by hand only – do not over tighten (figure 8a). Manual watering can also be achieved by turning the external bleed screen counterclockwise to start and clockwise to stop (figure 8b).

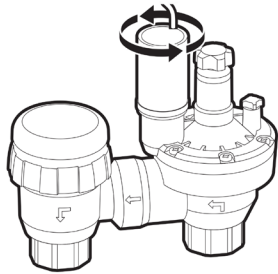

FIGURE 8A

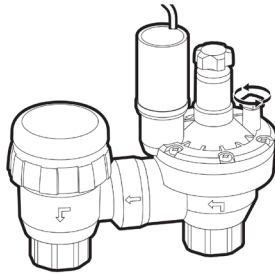



FIGURE 8B

14. CONNECTING A RAIN SENSOR

Most “normally closed” rain sensors can be connected to the 400A controller. The function of the sensor is to prevent automatic watering by the set program due to excessive rainfall.

To connect the sensor to the controller, please follow these steps:

1. Cut the yellow wire loop that exits the controller in the middle of the loop.
2. Strip approximately 1/2 in. of insulation from the end of each wire.
3. Splice one yellow wire to each of the wires coming from the sensor. Use waterproof wire connectors to secure the connections.
4. When the sensor is active and preventing automatic operation, the  icon will appear on the display.



The  icon will only appear when sensor is active or if the wire has been cut.

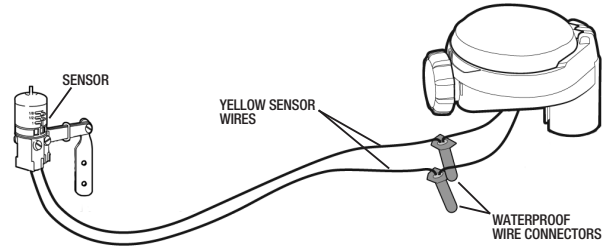

Recommended rain sensors are the Rain Bird RSD and Hunter Mini-Clik

15. CHANGING THE BATTERIES

The 400A controller batteries can last up to 3 years when using name-brand AA alkaline batteries. Actual battery life will depend on the sensitivity of the installed batteries to temperature ranges experienced by the controller as well as the number of valve operations programmed per day. To ensure proper operation, it is recommended that the 400A controller be checked regularly and the batteries replaced once the low battery indication starts flashing.



The 400A controller is designed to maintain the current time settings for up to 60 seconds with the batteries removed.

To change the batteries, see section 5.

Note: If the batteries are dead or drained, manual operation can also be accomplished by turning the solenoid counterclockwise, or by turning the external bleed screw counterclockwise. This will cause the valve to open. Both must be turned clockwise to close the valve.

16. MAINTENANCE, TROUBLESHOOTING AND REPAIRS

To restore the timer to the **default** settings

1. Press the  button until the **START EVERY** is displayed and the  icon appears on the bottom left of the screen.
2. Press and hold down the  for three seconds.
3. The screen returns to the home screen (clock) and all the default settings are restored. The current time and date is retained.

PROBLEM: Timer fails to open automatically or manually

CAUSE: No water pressure

SOLUTION: Open main water supply valve

CAUSE: Flow control knob is turned down

SOLUTION: Turn flow control knob counter clockwise to open

PROBLEM: Timer functions via the manual mode only but not automatically

CAUSE: Timer is set to OFF mode

SOLUTION: Verify that the timer does not show OFF in current time mode

CAUSE: AM/PM not set correctly in current time mode

SOLUTION: Check current time, change AM/PM if necessary

CAUSE: AM/PM not set correctly in start time mode

SOLUTION: Check start time(s), change AM/PM if necessary

CAUSE: Rain delay is preventing watering

SOLUTION: Set rain delay to off

CAUSE: Yellow sensor wires have been cut

SOLUTION: Re-connect sensor wires together with waterproof connector

CAUSE: Sensor is installed and is in a state that prevents watering

SOLUTION: Check sensor and wire splices and verify sensor is normally closed

PROBLEM: The display is blank

CAUSE: No buttons have been pushed in the previous 15 minutes

SOLUTION: Push any button

PROBLEM: Valve fails to close

CAUSE: Solenoid is loose

SOLUTION: Tighten solenoid by turning it clockwise to the right

CAUSE: Valve is installed backwards

SOLUTION: Check flow arrow and verify arrows points away from water source – reverse valve if necessary

CAUSE: Debris is blocking solenoid port

SOLUTION: Shut off water supply, unscrew and remove solenoid, then open water supply and flush out solenoid port, re-install solenoid

CAUSE: Flow control knob is too far open

SOLUTION: Turn flow control knob clockwise and retest

CAUSE: Drip System flow rate is below minimum flow rate

SOLUTION: Increase system flow rate by adding or changing drippers

PROBLEM: Rain sensor does not prevent watering

CAUSE: Rain sensor is normally open, malfunctioning, or not wired correctly

SOLUTION: Verify that sensor icon appears on display when pin is pushed down & check all wire splices

PROBLEM: Timer waters more than once per day

CAUSE: More than one start time has been programmed

SOLUTION: Change start time 2, 3, and 4 to OFF

PROBLEM: Water fails to stop discharging from Air Vent.

CAUSE: Poppet is out of alignment or missing

SOLUTION: Unscrew air vent cap and re-align poppet or replace air vent/poppet assembly

17. WARRANTY

DIG CORPORATION warrants these products to be free from defects in material and workmanship for a period of three years from date of purchase. This warranty does not cover damage resulting from accident, misuse, neglect, modification, improper installation or subjection to line pressure in excess of 125 lbs. per square inch for anti-siphon valves, in-line valves and for actuators. This warranty shall extend only to the original purchaser of the product for use by the purchaser.

The obligation of DIG CORPORATION under this warranty is limited to repairing or replacing at its factory this product which shall be returned to the factory within three years after the original purchase and which on examination is found to contain defects in material and workmanship. **DIG CORPORATION SHALL IN NO EVENT BE LIABLE FOR ANY INCIDENTAL OR CONSEQUENTIAL DAMAGES OF ANY KIND; THE SOLE OBLIGATION OF DIG BEING LIMITED TO REPAIR OR REPLACEMENT OF DEFECTIVE PRODUCTS. SOME STATES DO NOT ALLOW THE EXCLUSION OR LIMITATION OF INCIDENTAL OR CONSEQUENTIAL DAMAGES, SO THE ABOVE LIMITATION OR EXCLUSION MAY NOT APPLY TO YOU.**

Unattended use for prolonged periods without inspection to verify proper operation is beyond the intended use of this product, and any damage resulting from such use shall not be the responsibility of DIG CORPORATION. There are no warranties, which extend beyond the description on the face hereof. In the case of purchase of the product for use other than, for irrigation purposes, DIG CORPORATION hereby disclaims any implied warranties including any warranties of merchantability and fitness for a particular purpose. In the case of the purchase of the product for personal, family or household purposes, DIG CORPORATION disclaims any such warranties to the extent permitted by law. To the extent that any such disclaimer or implied warranties shall be ineffectual, then any implied warranties shall be limited in duration to a period of three years from the date of the original purchase for use by the purchaser. Some states do not allow limitation on how long an implied warranty lasts, so the above limitation may not apply to you.

In order to obtain performance under this warranty, the unit must be returned to the factory, along with proof of purchase indicating original date of purchase, shipping prepaid, addressed as follows:

DIG CORPORATION, 1210 Activity Drive, Vista, CA 92081. Repaired or replaced units will be shipped prepaid to the name and address supplied with the unit returned under warranty. Allow four weeks for repairs and shipping time. Repair of damaged units not otherwise within warranty may be refused or done at a reasonable cost or charge at the option of DIG CORPORATION.

This warranty gives you specific legal rights, and you may also have other rights, which vary from state to state.

18. TECHNICAL ASSISTANCE

Should you encounter any problem(s) with this product or if you do not understand its many features, please refer to this operating manual first. If further assistance is required DIG offers the following customer support:

DIGPRO™ Technical Service USA

DIG's Technical Service Team is available to answer questions in English and Spanish from 8:00 AM to 5:00 PM (PST) Monday-Friday (except holidays) at 800-344-2281.

Questions can be e-mailed to questions@digcorp.com or faxed to 760-727-0282.

Specification documents and manuals are available for download at www.digcorp.com.

Customer Assistance Outside the USA

Contact your local distributor.

19. TO ORDER REPLACEMENT OR SPARE PARTS: PLEASE ORDER ONLINE AT WWW.DIGCORP.COM

We at DIG Corporation understand that most dealers do not carry spare parts. For your convenience, if you need one of these parts, please order online at www.digcorp.com.

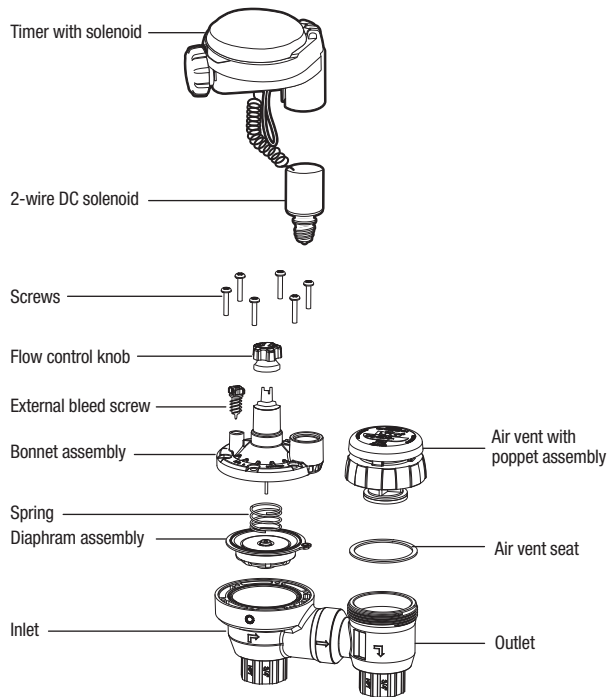



1210 Activity Drive
Vista, CA 92081-8510, USA

www.digcorp.com
e-mail: dig@digcorp.com

26-231 REVA 041221

Printed in the USA

DIG is a Registered Service Mark of DIG Corp.

