

### PARTS LIST:

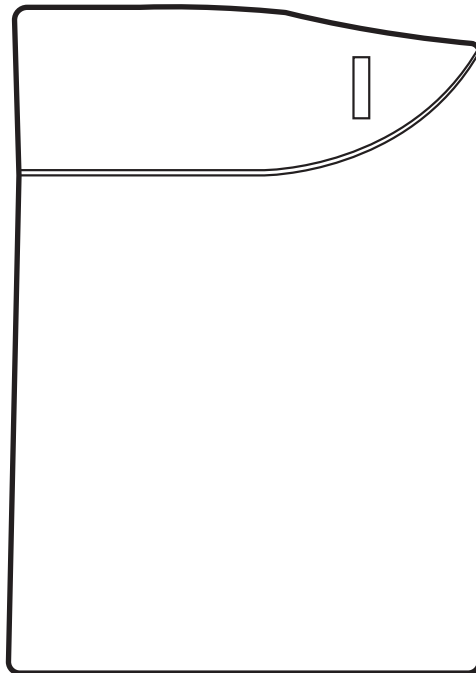

- 1 Magne-Lok Cab Shade
- 4 Metal D-Clips
- 2 Short A. Straps
- 2 Long B. Straps
- 1 Instruction Sheet
- Torx L Key

### SCAN FOR INSTRUCTIONAL VIDEO:

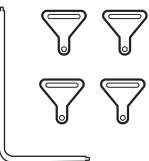
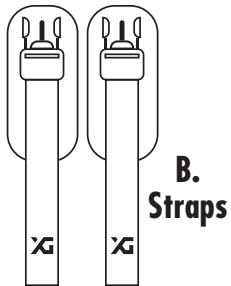
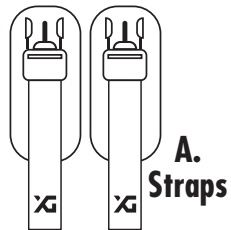
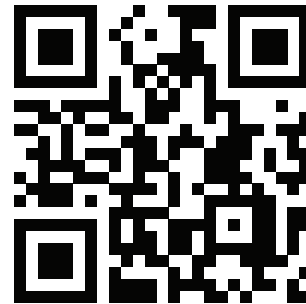

Scan the QR code with your smartphone and it will take you to the link below:

<https://qrgo.page.link/yYQYH>

### TOOLS NEEDED:

Torx L Key (included)

### INSTALLATION TIME & SKILL LEVEL:



5-10 minutes, Skill Level 01

### WARNING!

Magne-Lok Mesh Sun Shades are not intended to be used as a hammock or to store cargo. Magne-Lok is not a safety net and should not be considered a safety device in any manner. Do not over tighten straps as fatigue to straps, buckles and the sewing integrity of the product may be compromised. It is the end users responsibility to secure Magne-Lok prior to operating vehicle. Obey all traffic laws. Magne-Lok is weather resistant but should not be exposed to the sun for extended periods of time as all soft goods will degrade over time. Magne-Lok is warrantied for one year from the date of purchase. XG warrants all products for workmanship only and cannot assume responsibility for product abuse by the end user.

**STEP 01:**



Remove Magne-Lok Mesh Cab Shade, hardware kit and straps from box and lay Mesh Shade in sun for 5-10 minutes to soften before installation.

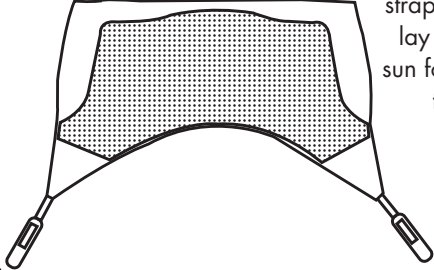

**STEP 02:**

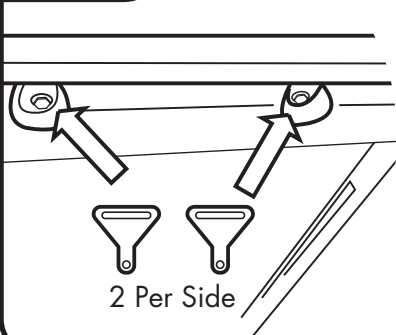

Install four (4) side buckle D clips and straps on each side as shown using the provided Torx driver. Align and tighten clips securely. **(A. straps in front)**

2 Per Side

**STEP 03:**

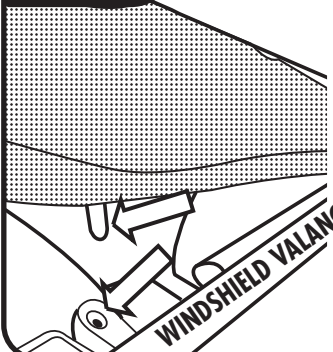

After 5-10 minutes in the sun, spread Magne-Lok across front of windshield as shown. Push both plastic locator pins into existing freedom panel locator holes and attach magnetic leading edge to windshield valance.

WINDSHIELD VALANCE

**STEP 04:**

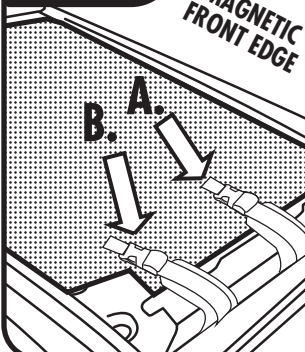

Attach all four side straps to Magne-Lok as shown with foam protectors facing sports bar. Tighten front strap A. evenly from side to side. Be sure Magne-Lok is centered between sport bars. **The B. straps are angled slightly to prevent locator pins from being pulled from their location after rear corner straps are tightened.**

MAGNETIC FRONT EDGE

**STEP 05:**

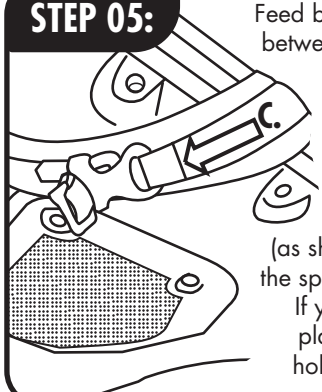

Feed back corner straps & buckles between hard top and sport bars. Yes, they fit! If it is easier to remove hard top for this installation, do so, but it is not necessary. Be sure the foam protector is between the buckle and sport bar (as shown) to prevent damage to the sport bar. Do not over tighten. If you over tighten and pull the plastic locator pins out of their holes, loosen C. straps slightly.

**STEP 06:**

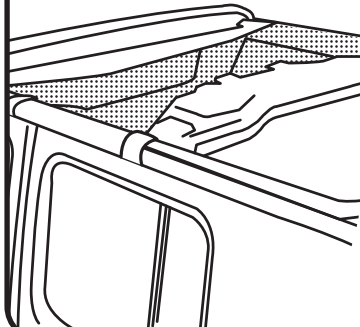

Moving from strap to strap, tighten as needed until Magne-Lok Mesh Cab Shade is tight and smooth while making sure the locator pins are intact. Flip Magne-Lok leading edge back and forth a few times to be sure pins are aligned and operational.