

Model No. MJ-C10

Two Post Lift,

Manual Release

Installation, Operation
and Parts Manual

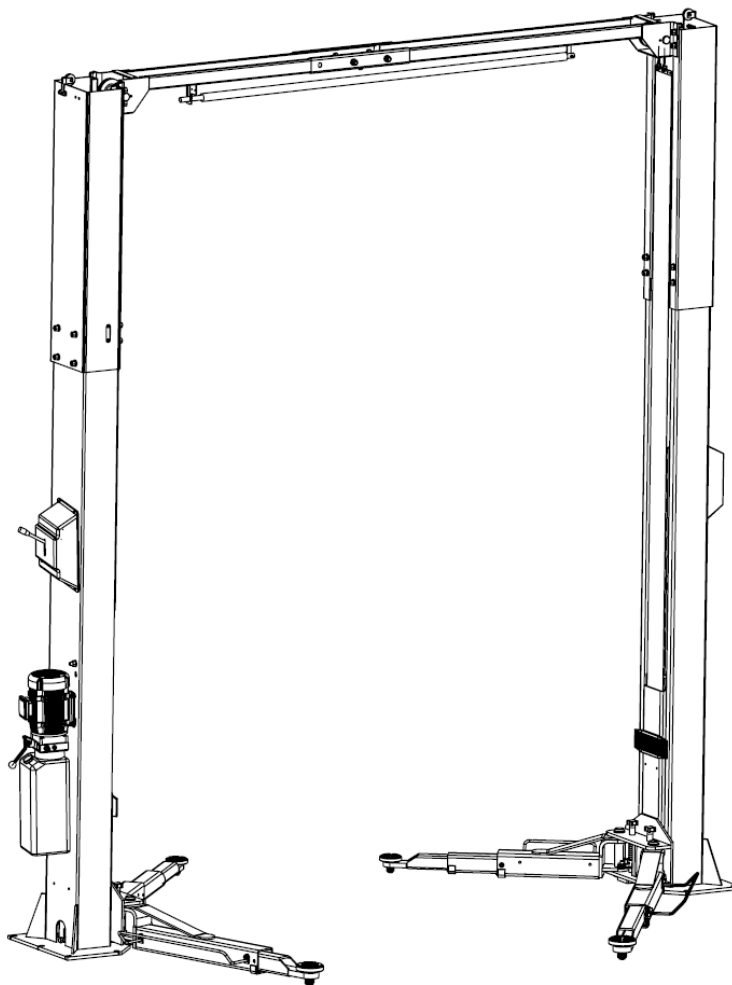

Distributed by

Please read this entire manual carefully and completely before installation or operation of the lift.

1-877-331-2222

IMPORTANT NOTES

Before start up, connecting and operating MAJOR products, it is absolutely essential that the operating instructions/owner's manual and, in particular the safety instructions are studied carefully. By doing so you can eliminate any uncertainties in handling MAJOR products and thus associated safety risks up front; something which is in the interest of you own safety and will ultimately help avoid damage to the device, When an MAJOR product is handed over to another person, not only the operating instructions but also the safety instructions and information on its designated use must be handed over to the person.

By using the product you agree the following conditions:

Copy right

The enclosed instructions are the property of MAJOR or its supplier, and are protected against duplication and reproduction by copyright laws, international agreements, and other domestic legislation. The reproduction or disclosure of instructions or an extract thereof is prohibited and offenders are liable to prosecution; MAJOR reserves the right or initiates criminal proceedings and asserts claims for damages in the event of infringements.

Warranty

The use of non-approved hardware will result in a modification of our products and thus to the exclusion of any liability or warranty, even if such hardware has been removed again in the interim.

It is not permissible to make any changes to our products and these are not only to be used together with genuine accessories and genuine replacement parts. Otherwise any warranty claims will be invalid.

Liability

The liability of MAJOR is limit to the amount that the customer has actually paid for this product. This exclusion of liability does not apply to damages caused through willful misconduct or gross negligence on the part of MAJOR.

All information in this manual is believed to be correct at time of publication.

MAJOR reserves the right to amend and alter technical data and composition without prior notice.

Please confirm at time of ordering.

IMPORTANT NOTES.....	2
SAFETY NOTES.....	4
1.1 Operation of lifting platforms	4
1.2 Checking of the lifting platforms.....	4
1.3 Important safety notices	5
1.4 Warning labels	6
1.5 Potential safety risks	7
1.6 Noise level	7
PACKING, STORAGE AND TRANSPORTATION	8
2.1 The lift was dismantled into the following 3 parts for transportation.....	8
2.2 Storage.....	8
2.3 Opening the packs.....	8
PRODUCTS DESCRIPTIONS.....	9
3.1 General descriptions.....	9
3.2 Construction of the lift	9
3.3 Technical data	10
3.4 Dimensions.....	11
3.5 Safety devices descriptions.....	12
INSTALLATION INSTRUCTIONS.....	13
4.1 Preparations before installation	13
4.2 Installation attentions.....	13
4.3 General installation steps.....	14
4.4 Items to be checked after installation.....	16
OPERATION INSTRUCTIONS.....	24
5.1 Precautions.....	24
5.2 Operation instructions	24
TROUBLE SHOOTING	26
INSPECTION AND MAINTENANCE	27
Annex 1, Floor plan	29
Annex 2, Electrical schemes and parts list	30
Annex 3, Hydraulic schemes and parts list.....	30
Annex 4, Mechanical exploded drawings and parts list.....	36

SAFETY NOTES

1.1 Operation of lifting platforms

This lift is specially designed for lifting motor vehicles. Users are not allowed to use it for any other purposes. The applicable national regulations, laws and directives must be observed.

Only users aged 18 or above who have been instructed on how to operate the lifting platform and have proven their ability to do so to the owner are to be entrusted with unsupervised operation of lifting platforms. The task of operating the lifting platforms must be granted in writing.

Before loading a vehicle onto the lift, users should study the original operation instructions and familiarize themselves with the operating procedures in several trial runs.

Lift vehicle within the rated load. Don't attempt to raise vehicles with excessive weight.

1.2 Checking of the lifting platforms

Checks are to be based on the following directives and regulations:

- Basic principles for testing lifting platforms
- The basic health and safety requirement
- The applicable accident prevention regulations

The checks are to be organized by the user of the lifting platform. The user is responsible for appointing an expert or qualified person to perform checking. It must be ensure that the person chosen satisfies the requirements.

The user bears special responsibility if employees of the company are appointed as experts or qualified persons.

1.2.1 Scope of checking

Regular checking essentially involves performing a visual inspection and a functional test. This includes checking the condition of the components and equipment, checking that the safety systems are complete and functioning properly and that the inspection log book is completely filled in. The scope of exceptional checking depends on the nature and extent of any structural modification or repair work.

1.2.2 Regular checking

After initial commissioning, lifting platforms are to be checked by a qualified person at intervals of not longer than one year.

A qualified person is somebody with the training and experience required to possess sufficient knowledge of lifting platforms and who is sufficiently familiar with the pertinent national regulations, accident prevention regulations and generally acknowledged rules of engineering to be able to assess the safe operating condition of lifting platforms.

1.2.3 Exceptional checking

Lifting platforms with a lift height of more than 2 meters and lifting platforms intended for use with people standing under the load bearing elements of the load are to be checked by an expert prior or reuse following structural modifications and major repairs to load bearing components.

An expert is somebody with the training and experience required to possess specialist knowledge of lifting platforms and who is sufficiently familiar with the pertinent national work safety regulations, accident prevention regulations and generally acknowledged rules of engineering to be able to check and give an expert opinion on lifting platforms.

1.3 Important safety notices

1.3.1 Recommend for indoor use only. DO not expose the lift to rain, snow or excessive moisture.

1.3.2 Only use this lift on a surface that is stable and capable of sustaining the load. Do not install the lift on any asphalt surface.

1.3.3 Read and understand all safety warnings before operating the lift.

1.3.4 Do not leave the controls while the lift is still in motion.

1.3.5 Keep hands and feet away from any moving parts. Keep feet clear of the lift when lowering.

1.3.6 Only these properly trained personnel can operate the lift.

1.3.7 Do not wear unfit clothes such as large clothes with flounces, ties, etc., which could be caught by moving parts of the lift.

1.3.8 To prevent evitable incidents, surrounding areas of the lift must be tidy and with nothing unsecured.

1.3.9 The lift is simply designed to lift the entire body of vehicles, with its maximum weight within the lifting capacity.

1.3.10 Always insure the safety locks are engaged before any attempt to work near or under the vehicle. Never remove safety related components from the lift. Do not use if safety related components are damaged or missing.

1.3.11 Do not rock the vehicle while on the lift or remove any heavy component from vehicle that may cause excessive weight shift.

1.3.12 Check at any time the parts of the lift to ensure the agility of moving parts and the performance of synchronization. Ensure regular maintenance and if anything abnormal occurs, stop using the lift immediately and contact our dealers for help.

1.3.13 Lower the lift to its lowest position and do remember to cut off the power source when service finishes.

1.3.14 Do not modify any parts of the lift without manufacturer's advice.

1.3.15 If the lift is going to be left unused for a long time, users are required to:

- a. Disconnect the power;
- b. Empty the oil tank;
- c. Lubricate the moving parts with hydraulic oil.

WARNING: The warnings, cautions and instructions discussed in this instruction manual cannot cover all possible conditions and situations that may occur. It must be understood by the operator that common sense and caution are factors which cannot be built into this product, but must be supplied by the operator.

1.4 Warning labels

All safety warning labels are clearly depicted on the lift to ensure that the operator is aware of and avoid the dangers of using the lift in an incorrect manner. The labels must be kept clean and they have to be replaced if detached or damaged. Please read carefully the meaning of each label and memories them for future operation.

SAFETY ADVICE

540101441

	Only trained personnel are allowed to operate the lift.
	Always keep lift area clear when lowering or raising vehicle.
	Do not try to raise a vehicle exceeds the rated capacity.
	Always raise a vehicle with four swing arms.
	Position and adjust pads to lifting points recommended by vehicle manufacturers.

	Stop and check lift arm locks and stability of vehicle after short raising, then to desired height.
	Watch closely the vehicle during raising or lowering.
	Always use safety stands when moving/ installing heavy components.
	Avoid excessive rocking of vehicle while on lift.
	Travelling on the load carrying devices is forbidden.

1.5 Potential safety risks

1.5.1 Mains voltage



Insulation damage and other faults may result in accessible components being live

Safety measures:

- Only ever use the power cord provided or a tested power cord.
- Replace wires with damaged insulation.
- Do not open the operating unit.

1.5.2 Risk of injury, danger of crushing

In the event of excessive vehicle weight, incorrect mounting of the vehicle or on removing heavy object, there is a risk of the vehicle falling off or tipping up.

Safety measures:

- The lift is only ever to be employed for the intended purpose.
- Carefully study and heed all the information given in Section 1.4.
- Observe the warning notices for operation.

1.6 Noise level

Noise emitted during operating the lift should be less than 70dB (A). For your health consideration, it is suggested to place a noise detector in your working area.

PACKING, STORAGE AND TRANSPORTATION

Packing, lifting, handling, transporting operations must be performed only by experienced personnel with appropriate knowledge of the lift and after reading this manual.

2.1 The lift was dismantled into the following 2 parts for transportation

<i>Name</i>	<i>Packed by</i>	<i>Quantity</i>
<i>Lift –C10M</i>	<i>Steel brackets</i>	<i>1</i>
<i>Power unit –C10M</i>	<i>Carton</i>	<i>1</i>

2.2 Storage

The packs must be kept in a covered and protected area in a temperature range of -10°C to +40°C. They must not be exposed to direct sunlight, rain or water.

Stacking the packs

We advise against stacking because the packs are not designed for this type of storage. The narrow base, heavy weight and large size of the packs make stacking difficult and potentially dangerous.

If stacking is unavoidable, use all appropriate precautions:

-never stack to more than 2 meters in height.

-never make stacks of single packs. Always stack pairs of packs in a cross pattern so that the base is bigger and the resulting stack is more stable. Once the stack is complete, restrain it using straps, ropes or other suitable methods.

A maximum of two packs can be stacked on lorries, in containers, and in railway wagons, on condition that the packs are strapped together and restrained to stop them falling.

2.3 Opening the packs

The packs can be lifted and transported only by using lift trucks. Never attempt to hoist or transport the unit using lifting slings.

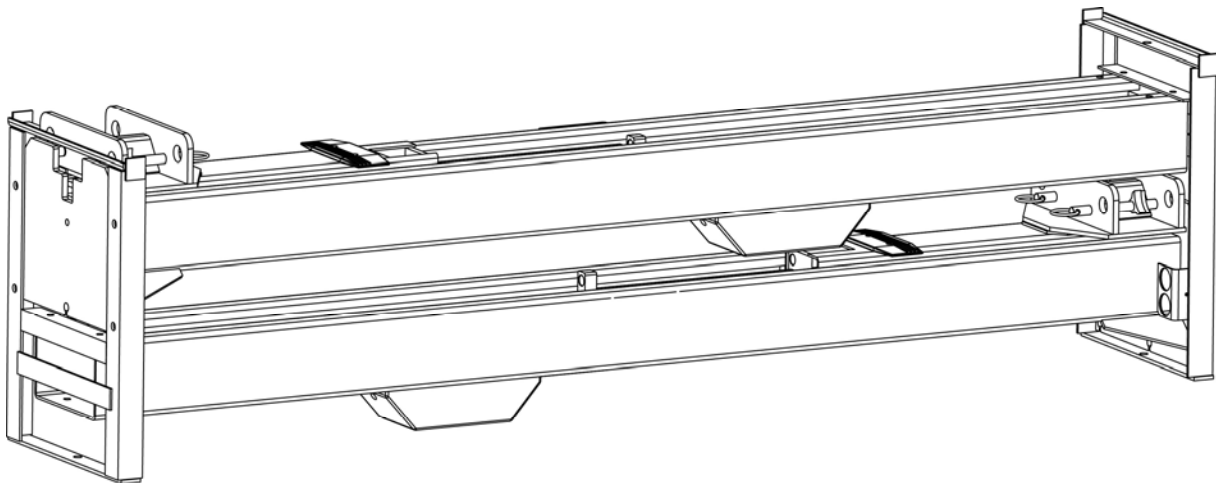

When the lift is delivered make sure that it has not been damaged during transportation and that all the parts specified on the packing list are present.

Packs must be opened adopting all the precautions required to avoid injury to persons (keep at a safe distance when cutting the straps) or damage to parts of the machine (be careful that no parts are dropped while you are opening the packing).

Take special care with the hydraulic power unit, the control panel and the cylinder.

PRODUCTS DESCRIPTIONS

3.1 General descriptions

This is chassis supporting vehicle lift for road vehicles.

It is mainly composed by two posts, two carriages, four swing arms and a power and control unit.

It is driven by an electro-hydraulic system. The gear pump delivers hydraulic oil to oil cylinders and pushes upwards its piston. The cylinder piston drives to raise the carriage and swing arms. It is equipped with mechanical safety locking unit which ensures no risks of slipping off in case of hydraulic failure.

3.2 Construction of the lift

1. Overhead crossbeam
2. Extending post
3. Mechanical safety latch
4. Carriage
5. Hydraulic power unit
6. Lifting arm

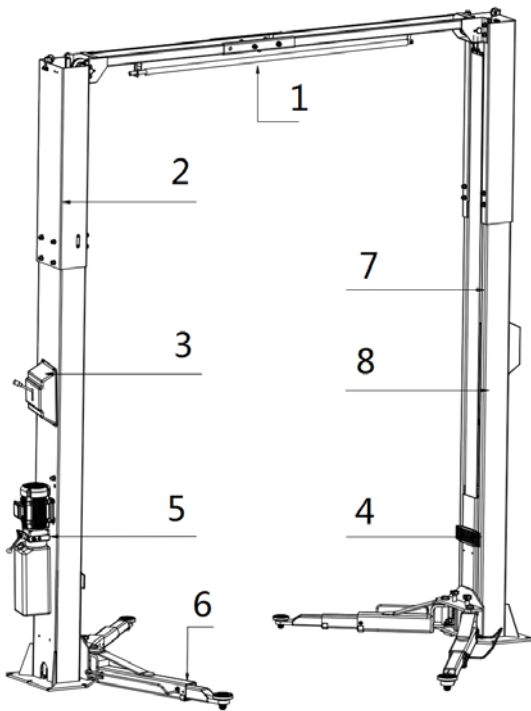

7. Hydraulic cylinder

8. Post

3.3 Technical data

Lifting capacity	10000 lbs.
Full rise	1729mm
Min height	85mm (low profile arm)
Full rise time (with rated load)	Approx.60s
Full descent time (with rated load)	Approx.50s
Power Supply	380V/400V/415V-3ph-50Hz/60Hz 220V/230V/240V-1ph-50Hz/60Hz
Oil tank volume	10L

3.4 Dimensions

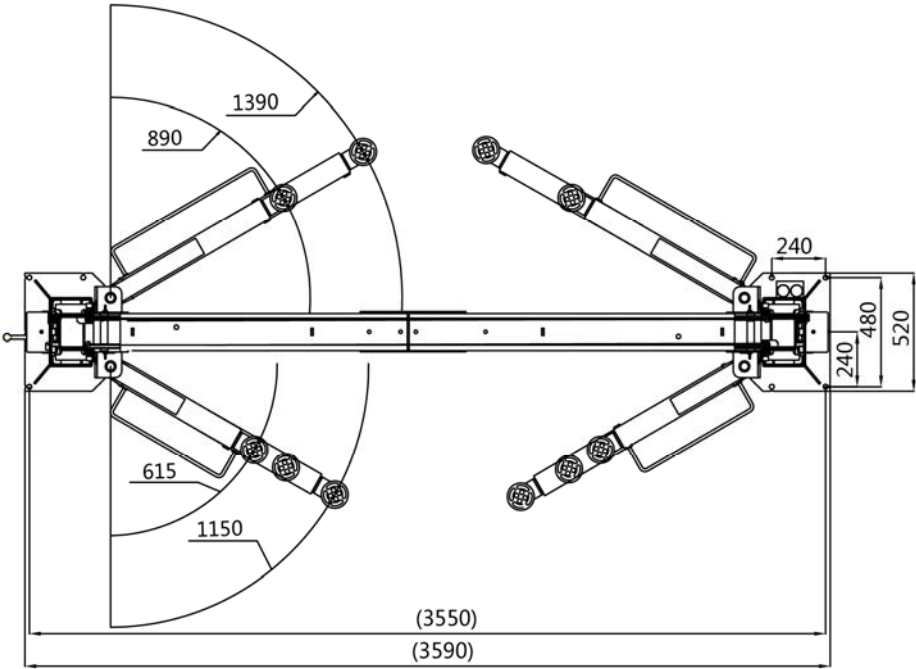
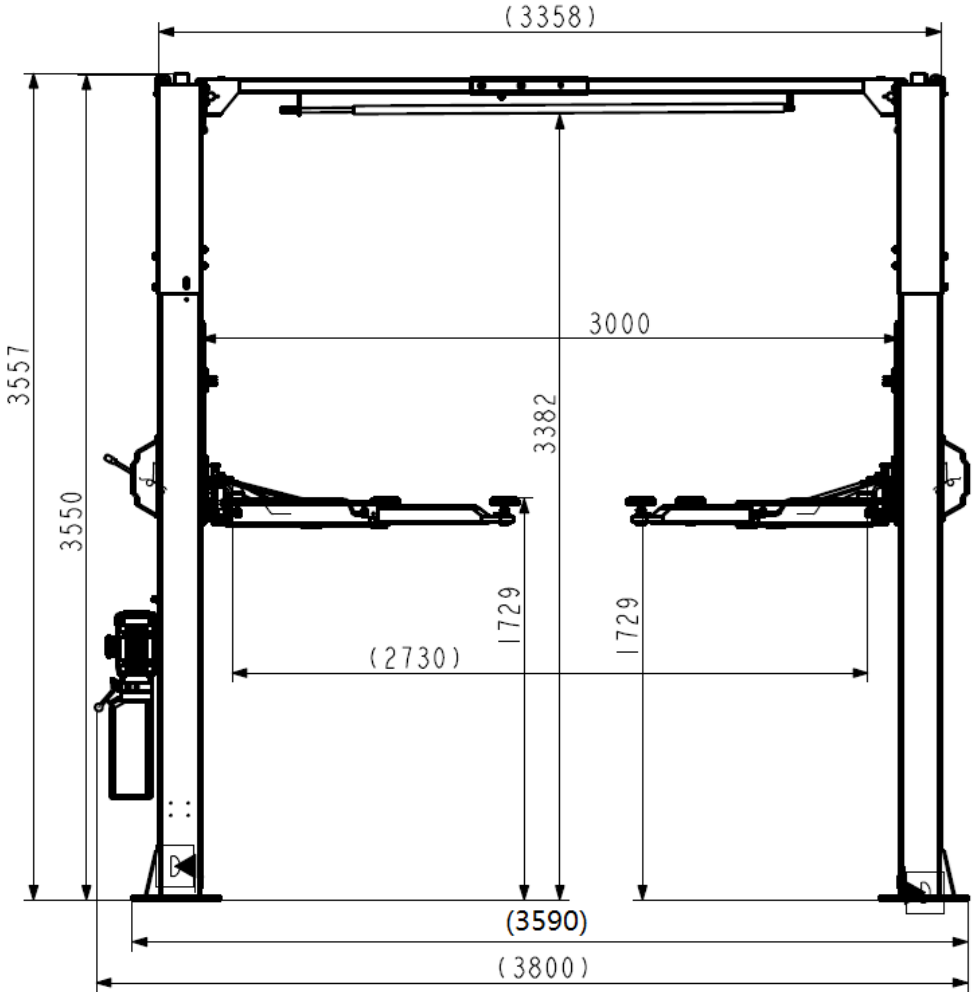

3.5 Safety devices descriptions

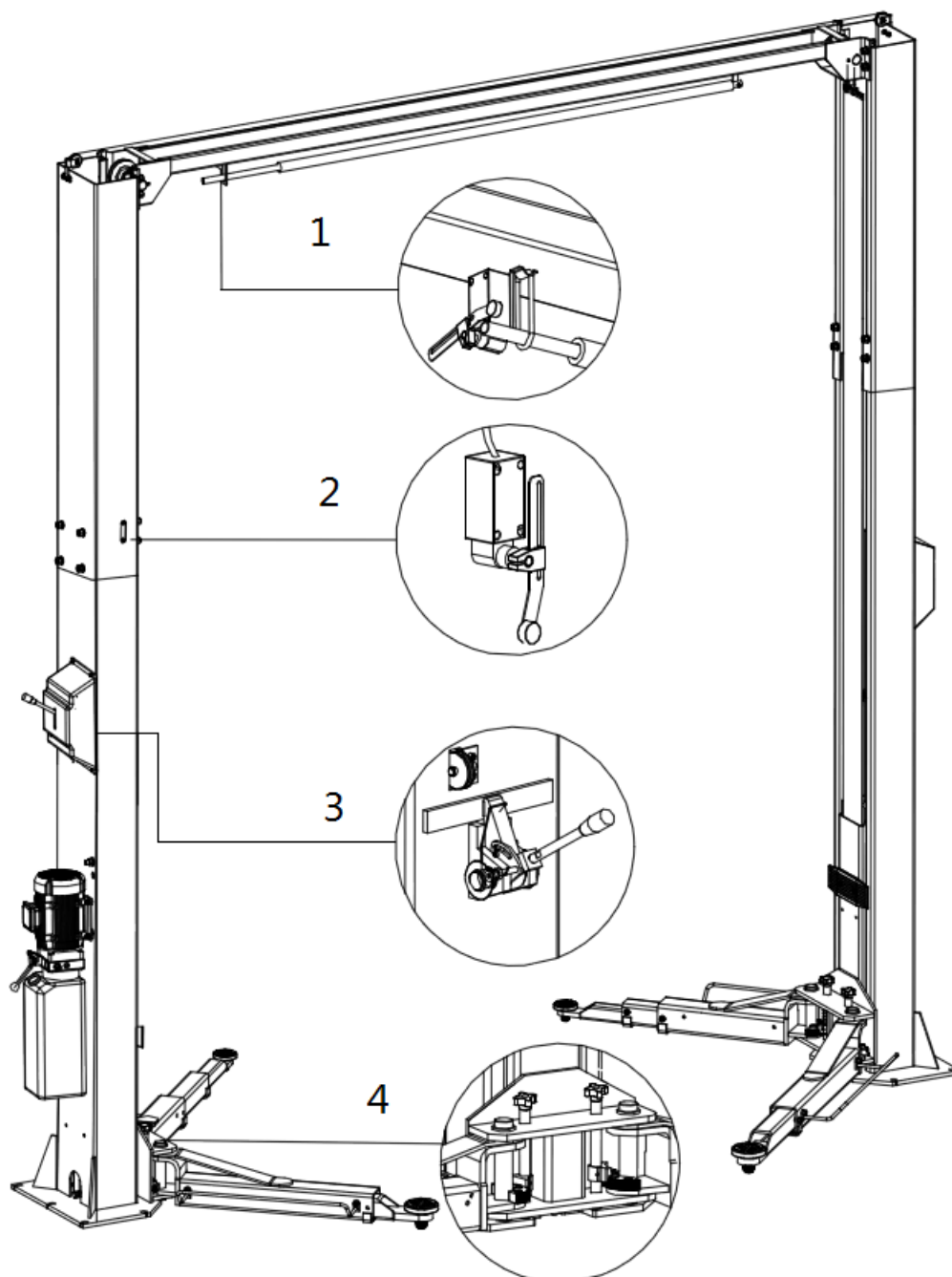

POS.	Description	Function
1	Roof protective limit switch	Stop rising in case the overhead bar is touched.
2	Max rise limit switch	Stop rising at max height.
3	Mechanical safety locking unit	Catch the carriages in case of hydraulic failure.
4	Arm lock	Ensure the lifting arms are locked and avoid being swinging during lifting process.

INSTALLATION INSTRUCTIONS

4.1 Preparations before installation

4.1.1 Space requirements.

Refer to 3.4 for the dimensions of the lift. There must also be a clearance of at least 1 meter between the lifting platform and fixed elements (e.g. wall) in all lifting positions. There must be sufficient space for driving vehicles on and off.

4.1.2 Foundations and connections

The user must have the following work performed before erecting the lift.

Construction of the foundation following consultation with the manufacturer’s customer service or an authorized service agent. Routing of the wiring to the installation location. **The user must provide fuse protection for the connection. Electrical system connection must be done by licensed technicians.** Requirements for power supply cable of the installation site: at least 2.5mm² wire core for 3Ph power and 4.0mm² wire core for 1Ph power.

Refer also to the corresponding information on the name plate and in the operation instructions.

Before doing electrical connection, make sure the lift is electrically adapt to the local power supply.

4.1.3 Foundations preparations

Refer to Annex 1 for footing.

C25 concrete foundation with a minimum thickness of 200mm (continuous footing).

Surface: Horizontal and even (Gradients max. 0.5 %)

Newly built concrete ground must be older than 20days.

4.1.4 Tools and equipment needed for installation

Tool name	Specification	Quantity
Electrical drill (C10)	D18 drill bit	1
Open spanner	D17-19	2
Adjustable spanner	bigger than D30	1
Cross socket screw driver	PH2	1
Quick spanner handle adapter/ Ratchet	REB-310	1
Socket spanner	D24	1
Levelling device	Accuracy: 1mm	1
Hammer	10 pounds	1
Truck lift	Capacity,1000kg	1
Lifting string	Capacity, 1000kg	2
Torque spanner	MD400	1

4.2 Installation attentions

4.2.1 Joints of oil hose and wiring must be firmly connected in order to avoid leakage of oil hose and looseness of electrical wires.

4.2.2 All bolts should be firmly screwed up.

4.2.3 Do not place any vehicle on the lift in the case of trial running.

4.3 General installation steps

ONLY TRAINED AND QUALIFIED INSTALLERS CAN PERFORM LIFT INSTALLATION DUTIES.

Step 1: Remove the packaging and take out the accessories attached.

Attention : The packs must be opened adopting all the precautions required to avoid injury to persons (keep at a safe distance when cutting the straps) or damage to parts of the machine (be careful that no parts are dropped while you are opening the packing).

Use proper means (put something supporting under the post or suspend the post by a crane) to suspend the post, unscrew and remove the bolts fixed on the iron rack.

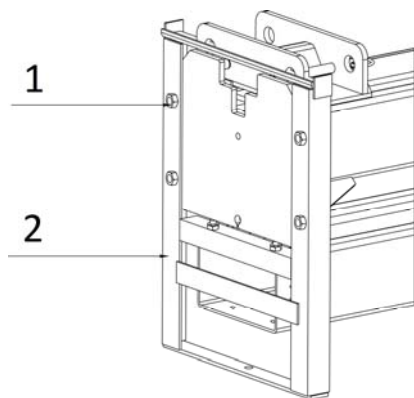

- 1. Hex bolt
- 2. Iron rack

Attention : Please pay special attention not to let the post fall down for it may cause casualty or bring damages to the accessories fixed in the post.

Step 2: Fix the standing position for the two posts. (See Annex 1, floor plan)

1. Decide on which post the power unit is going to be mounted.
2. Draw an outline of the base plate on the installation ground with chalk and ascertain the position for the two posts.

Step 3: Assemble the two posts.

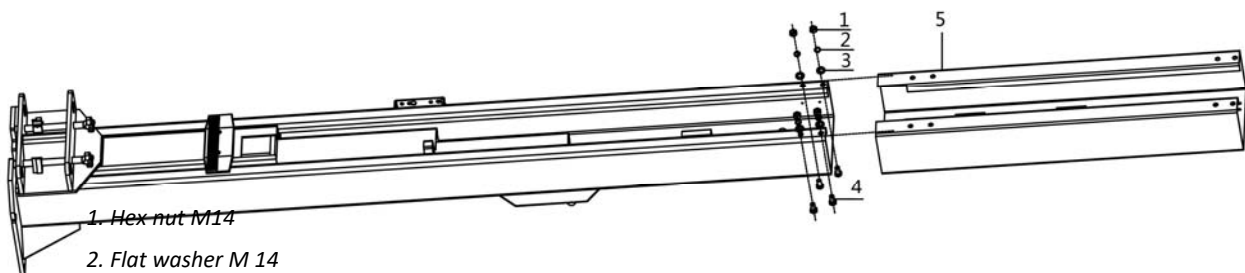

- 1. Hex nut M14
- 2. Flat washer M 14
- 3. Spring washer M14
- 4. Hex head full swivel screw M14*30
- 5. Extending post

Step 4: Erect and secure the post.

1. Make the posts face to each other and the distance between the posts equals to the length of the crossbeam. Use proper means to erect the post.
2. Use suitable means to raise the lifting carriage to the first latching position. All the mounting holes in the base plate are then accessible. Make sure the locking pawl is engaged.
3. Check and align the position of the base plates again.
4. Drill the mounting holes. Remove the drilling dust from the hole.
5. Use a spirit level to check the vertical alignment of the posts. If necessary, place equalizing plates under the base plates.
6. Tighten the nuts. **Torque: (63-74b.ft) 80-100Nm**

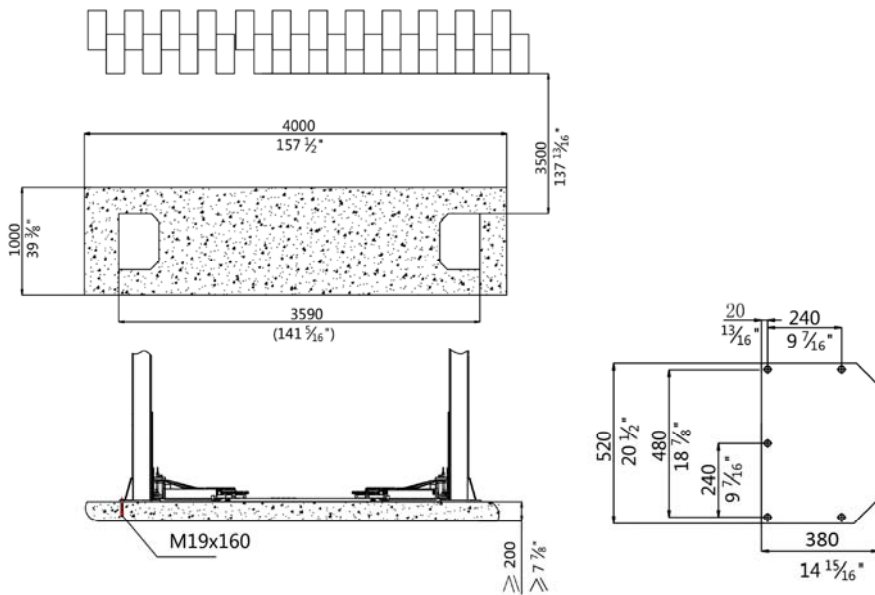

- A. Nut
- B. Expansion anchoring bolt
- C. Equalizing plate

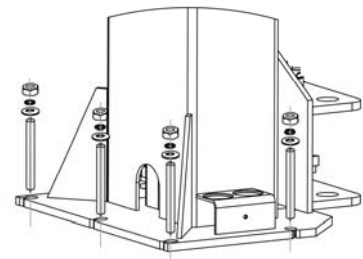
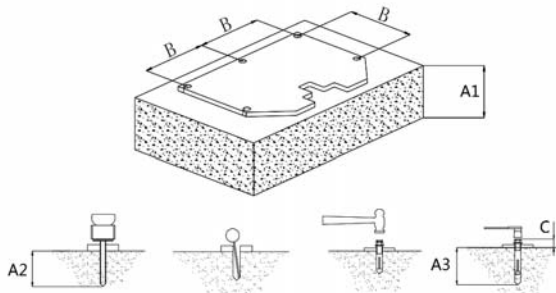
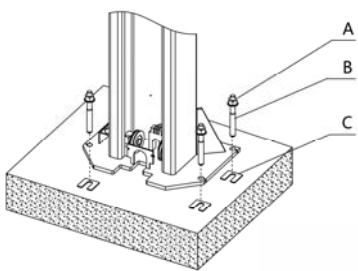

Anchoring bolt	A1 (foundation thickness)	A2 (drilling depth)	A3 (anchoring depth)	B	C
----------------	------------------------------	------------------------	-------------------------	---	---

M19x160	≥200mm	130mm	105mm	240mm	≤55mm
---------	--------	-------	-------	-------	-------

Step 5: Connect and install the crossbeam.

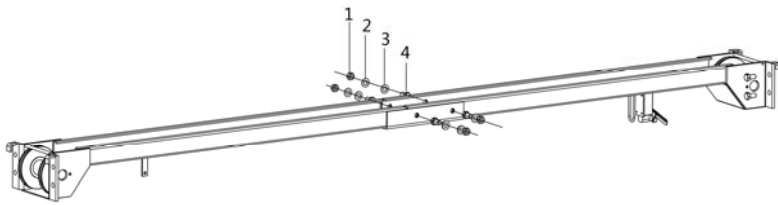

1. Hex nut M14
2. Flat washer M14
3. Spring washer M14
4. Hex head full swivel screw M14*30

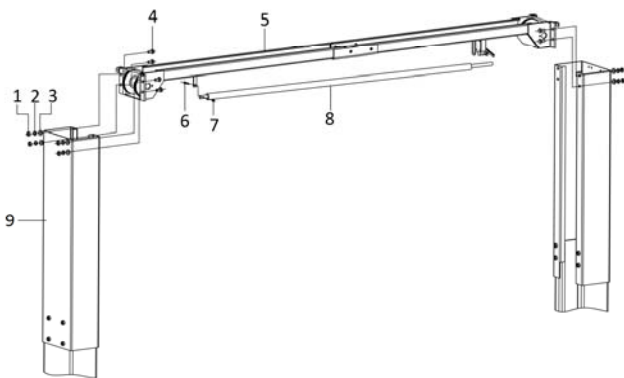

1. Hex nut M14
2. Flat washer M14
3. Spring washer M14
4. Hex head full swivel screw M14x30
5. Crossbeam
6. Hex socket cylinder head screw M6x30
7. Hex nut M6
8. Protective rod
9. Extending post

Step 6: Connect the synchronization steel cable.

1. Route and fix according to the following scheme.
2. Before attempting to route the cables, raise the lifting carriage at both sides to the first latching position making sure that the mechanical safety locking units in each post are fully engaged.
3. After fixed the cables, adjust and make the cables at both sides be under the same tension which could be judged by the sound emitted during lifting process.
4. Grease the cable after being fixed. (It is a must.)

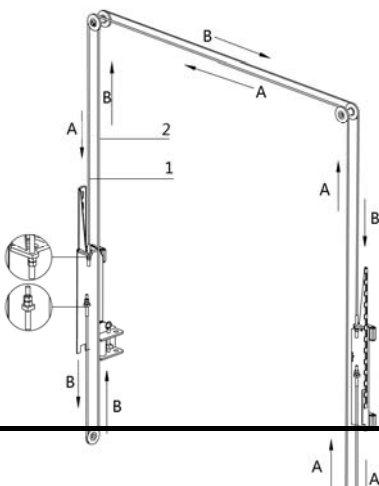

1. Steel cable A

2. Steel cable B

Step 7: Install hydraulic power unit onto the power side post.

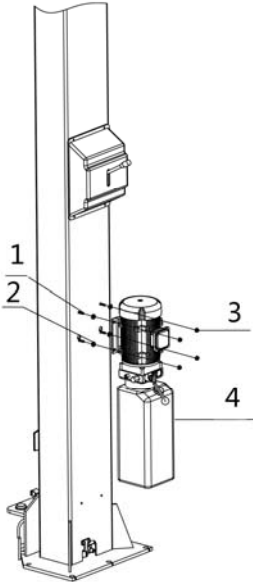

1.Hex head flange bolt M8x30

2.Anti-vibration pad

3.Hex head flange nut M8

4.Hydraulic power unit

Step 8: Connect the hydraulic hoses

Connect oil hoses according to the following diagram.

It must be taken adequate care that all fittings are securely tightened and no solid substance go into the hydraulic line, otherwise severe leakage will occur.

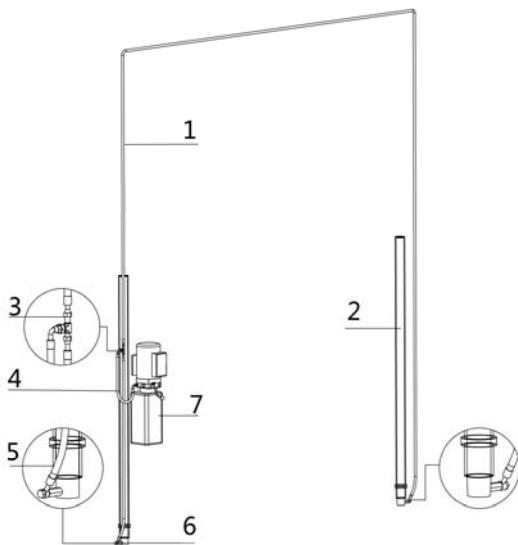

1.Oil hose A

2.Hydraulic cylinder

3.Three way connector

4.Oil hose B

5.Oil hose C

6.Composite connector

7.Power unit

Step 9: Make the electrical connection.

ONLY qualified electricians are permitted doing the electrical connection.

Read the name plate and check that the supply voltage is adapted to the voltage of the lift.

Refer to Annex 2 before doing the connection.

1. Fix max height limit switch onto the inside surface of the power side post and connect its wire to the terminals reserved at the motor.

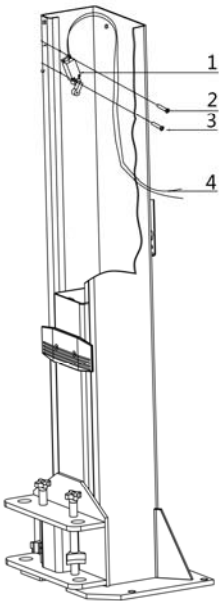

1. Max height limit switch
2. Cross socket flat head screw M5x10
3. Cross socket flat head screw M5x10
4. Wire

2. Fix roof protection limit switch onto the overhead crossbeam and connect its wire.

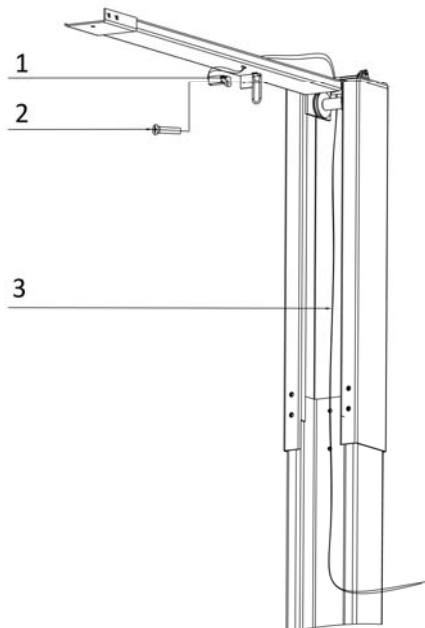

1. Limit switch
2. Hex socket screw M4x25
3. Wire

3. Refer to the wire connection schemes and connect wires to the corresponding terminals in the control box.

Step 10: Assemble and fix the mechanical safety locking unit.

a. Assemble the locking device.

Locking assembly at the power-side post

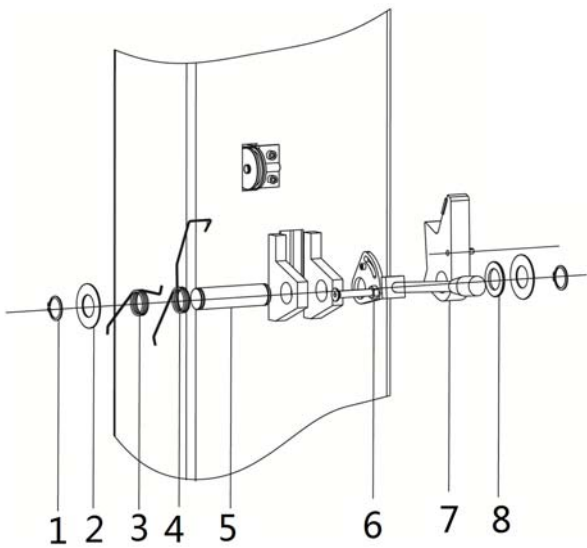

- 1.circlip
- 2.washer
- 3.spring 1
- 4.spring 2
- 5.shaft
- 6.handle bar
- 7.hook
- 8.nylon spacer
- 9.release plate

Locking assembly at the other post

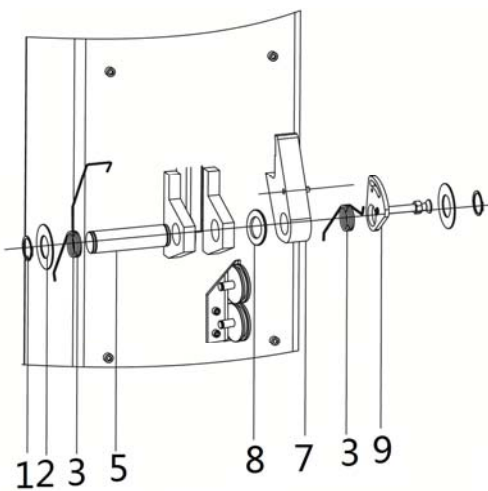

2. Route and fix the release rope for mechanical safety locking assembly.

2.1 Make release rope goes through pulleys on top of the two posts and fix the release rope at both sides of the post.

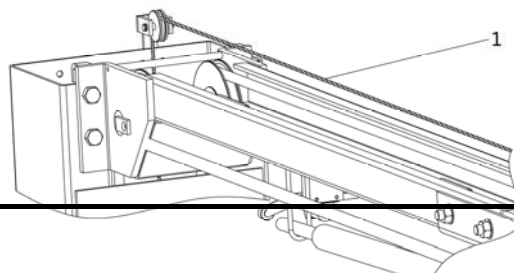

secondary post

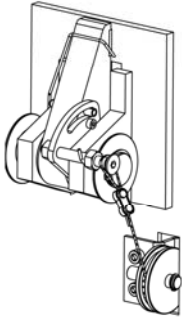

power side post

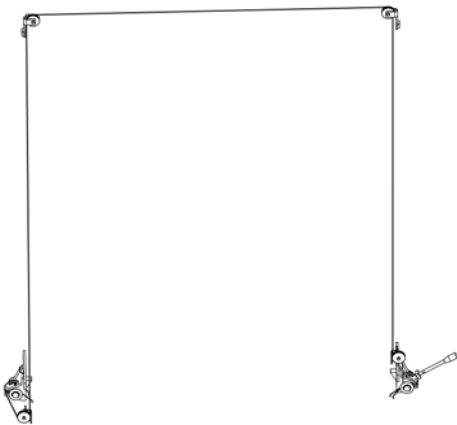
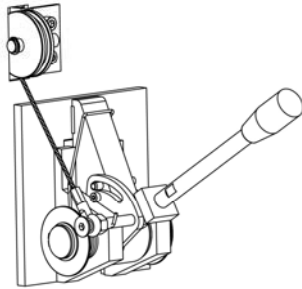

2.2 Install the protective cover

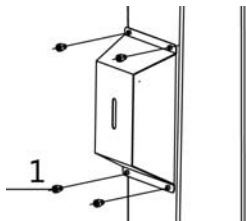

1.Hex socket cylinder head screw M6*8

Step 11: Install lifting arms.

The arm pin shafts (No. 2) must be greased at the installation.

Install the lifting arms onto the carriages and ensure the arm lock could work.

Attention: Install Lifting arms ONLY after the complete assembly has been erected and anchored.

- 1.Carriage
- 2.Pin shaft
- 3.Long arm
- 4.Pulling rod
- 5.Arm lock

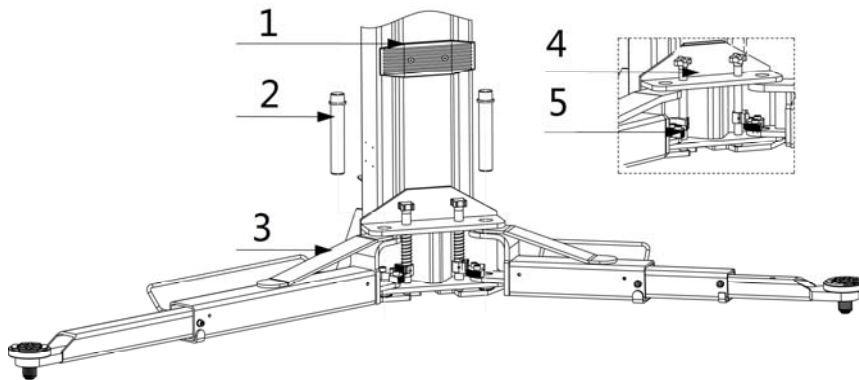

Step 12: Fill with hydraulic oil.

ONLY CLEAN AND FRESH OIL ONLY

Lift must be fully lowered before changing or adding hydraulic oil.

Prepare 12 liters anti-abrasion hydraulic oil. Fill about 10 liters into the oil tank to run the lift up and down for 2 or 3 times after the electrical system is connected.

Add more oil after running the lift for several cycles until the lift can rise to the maximum lifting height.

Note: It is suggested to use HM NO.46 hydraulic oil when average temperature of the location is above 18 degree Celsius and using HM NO.32 hydraulic oil when temperature is below 10 degree Celsius.

Change the oil 6 months after initial use and once per year thereafter.

Step 13: Trial running.

Get familiar with lift controls by running the lift through a few cycles before loading vehicle on lift. This step is of particular importance as it can check if the oil hose is correctly connected. The connection is qualified when there is no abnormal sound or leakage after having been tested for 5-6 times.

If the lift doesn't raise, the motor may turn in the wrong direction. In such event, interchange wires U, V in the connection box.

Bleeding the hydraulic system

Unscrew but don't remove the nut on top of the oil cylinder and slightly press the UP button until oil gets out. Screw the nut tight thereafter.



Vent air remained in the cylinder

After bleeding system, fluid level in power unit reservoir may be down. Add more fluid if necessary to raise lift to full height. It is only necessary to add fluid to raise lift to full height.

Check the synchronization of both lifting carriages.

Ensure the synchronization by adjusting the balance steel cables at both sides. Make both cables be of the same tightness.

This could be judged by the sound emitted by the safety locking unit during lifting process.

Check the mechanical safety locking unit.

Check and ensure both safety locking hooks can be effectively engaged or released.

Step 14: Fix the protective column curtain.

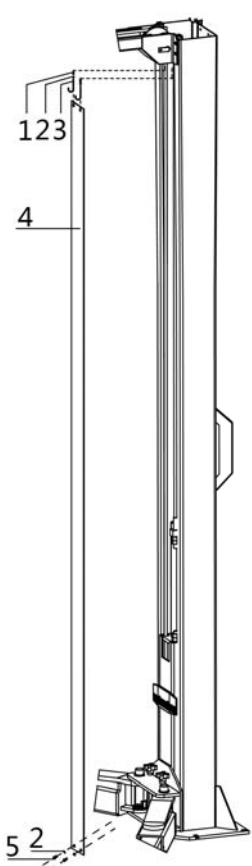

- 2. Class C flat washer M6
- 3. Hook
- 4. Column curtain.
- 5. Cross socket cap head screw M6x8

Step 15: Install the height adapter holder. (Optional)

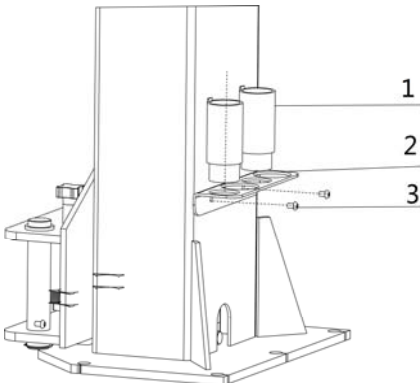

- 1. Height adapter
- 2. Holder
- 3. Hex socket button head screw M8x12

4.4 Items to be checked after installation

S/N	Check items	YES	NO
1	Screw torque of expansion bolts : 80-100Nm (63-74b.ft);	√	
2	Rising speed $\geq 20\text{mm}((7/8''))/s$;	√	
3	Noise with load $\leq 75\text{dB(A)}$;	√	
4	Grounding resistance: not bigger than 4Ω ;	√	
5	Height difference of the two carriages $\leq 5\text{mm}$;	√	
6	Mechanical catch unit is robust and synchronized when running with rated load ;	√	
7	All control buttons works as "hold to run".	√	
8	The limit switches work well.	√	
9	The grounding wire is connected.	√	
10	The carriage rises and lowers smoothly.	√	
11	There is no abnormal noise when run with load.	√	
12	There is no oil leakage when run with load.	√	
13	The expansion bolts, nuts or circlips are well secured or tightened.	√	
14	The max lifting height can be reached.	√	
15	All Safety advices, name plate and logos are clear.	√	

OPERATION INSTRUCTIONS

5.1 Precautions

- ONLY authorized persons are permitted in the lift area.
- Do not try to raise the vehicle with excessive length or width. Otherwise there is risk of vehicle falling from lift.
- Inspect the space above and below the load and the loading carrying devices. It shall be free of obstructions before operating.
- Before raising operation, run the lift without load for a complete cycle to ensure it is in good condition.
- Before lifting the vehicle and during all operations on the vehicle, make sure that it is properly stopped by the hand brake.
- Check the vehicle after raising a short distance to ensure that it is correctly and safely positioned.
- It is forbidden for people to stand in the field of motion during raising or lowering movement.
- The load carrying device shall be observed by the operator throughout the motion of the lift.
- Engage the safety locking mechanism before entering under the raised vehicle.
- Avoid excessive rocking of vehicle while on the lift
- Always use safety stands when moving or installing heavy components.
- Do not climb onto the load or load carrying device when they are raised.

5.2 Operation instructions

Only one operator is allowed to work around the vehicle lift.

Always engage the safety locking mechanism before any operation on the lifted vehicle.

Do not make any operation on the lifted vehicle at a height under the first latching position (less than 500mm).

Never attempt to lower the lifted vehicle to the bottom when any of its wheel is removed unless you are assured that no damage will occur.

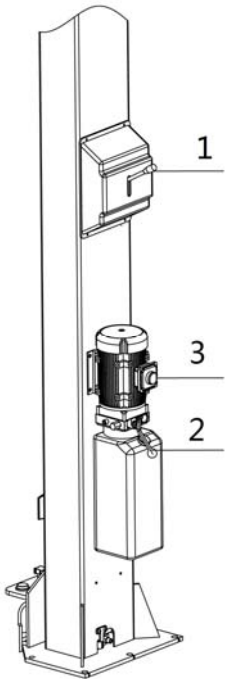

POS.	Descriptions	Function
1	Unlocking handle	Release the mechanical locking unit.
2	Lowering handle	Control descending movement. Engage the mechanical locking unit.
3	UP button	Push to control the rising movement.

To avoid personal injury and/or property damage, permit only trained and qualified personnel to operate the lift. After reviewing these instructions, get familiar with lift controls by running the lift through a few cycles before loading vehicle on lift. Always lift the vehicle using all four adapters. Never raise just one end, one corner or one side of vehicle adapters.

Raise the lift

Make sure vehicle is neither front nor rear heavy and center of balance should be midway between adapters and centered over the lift.

1. Park the vehicle between two posts.
2. Adjust the lifting arms until lifting adapters are under the pick-up positions of the vehicle and make sure the gravity of vehicle located over the center of four lifting arms.
3. Push the "UP" button until lifting adapters have touched the pick-up positions of vehicle.
4. Keep on raising the vehicle making its wheels have a bit clearance off the ground and check again the stability.
5. Raise the vehicle to the expected height, push the "Lowering handle" to engage the mechanical safety locking unit. Check again the stability before doing maintenance or repair work underneath.

Lowering

When lowering the lift pay careful attention that all personnel and objects are kept clear.

1. Push the "UP" button to disengage the mechanical locking unit.
2. Push down the unlocking handle to release mechanical locking unit and meanwhile push down the lowering handle.
3. When the lift is fully lowered, position the lift arms and adapters to provide an unobstructed exit before removing vehicle from lift area.

4. Drive the vehicle away.

TROUBLE SHOOTING

ATTENTION: If the trouble could not be fixed by yourself, please do not hesitate to contact us for help. We will offer our service at the earliest time we can. Troubles could be judged and solved much faster when more details or pictures could be provided.

TROUBLES	POSSIBLE CAUSES	SOLUTIONS
Abnormal noise	Abrasion exists on insides surface of the posts.	Grease the inside of the post.
	Trash in the post.	Clear the trash
Motor does not run and will not rise	Loose wire connection	Check and make a good connection.
	Blown motor.	Replace it.
	Damaged limit switch or its wire connection is loose.	Adjust or replace the limit switch.
Motor runs but will not raise	The motor run reversely.	Check the wire connection.
	Relief valve is not well screwed up or jammed.	Clean or make adjustment
	Damaged gear pump.	Replace it.
	Too low oil level.	Add oil.
	The hose connection is loose.	Tighten it.
Carriages go down slowly after being raised	The cushion valve is not well screwed up or jammed.	Clean or make adjustment
	The oil hose leaks.	Check or replace it.
	Untightened oil cylinder.	Replace the seal.
	The single way valve leaks.	Clean or replace it.
	Unloading valve fails to work well.	Clean or replace it.
Raising too slow	Slack steel cable	Check and adjust the tightness.
	Jammed oil filter	Clean or replace it.
	Too low oil level.	Add oil.
	The relief valve is not adjusted to the right position.	Make adjustment.
	Too hot hydraulic oil (above 45°) .	Change the oil.
	Abraded seal of the cylinder	Replace the seal.
Lowering too slow	Inside surface of the posts is not well greased.	Add grease.
	Jammed throttle valve	Clean or replace.
	Dirty hydraulic oil	Change the oil.
	Jammed anti-surge valve	Clean it.
The steel cable is abraded	Jammed oil hose	Replace it.
	No grease at installation or out of lifetime	Replace it.

INSPECTION AND MAINTENANCE

Easy and low cost routine inspection and maintenance can ensure the lift work normally and safely.

Follow the below routine inspection and maintenance schedule with reference to the actual working condition and frequency of your lift.

Lubricate moving parts with NO.1 lithium based grease.

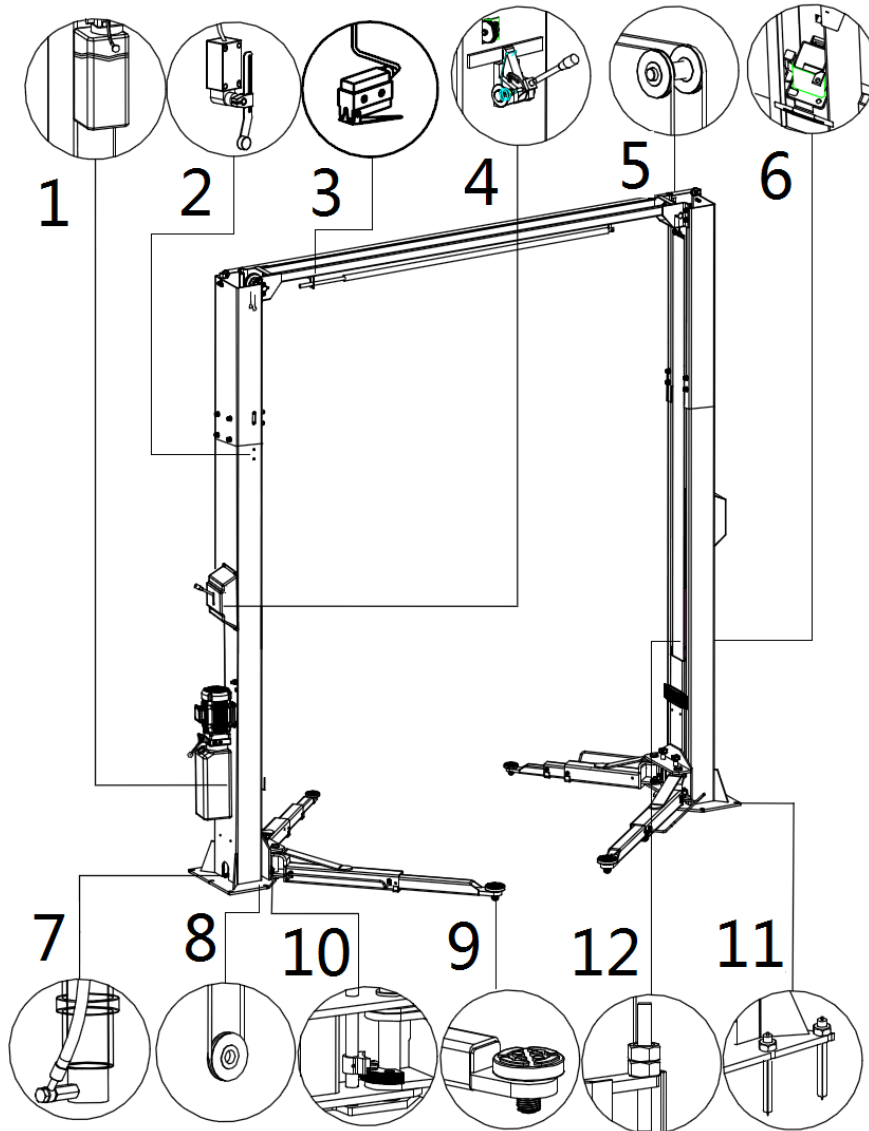

S/N	Components	Methods	Period
1	Hydraulic oil	Change the oil 6 months after initial use and once per year thereafter. Inspect the hydraulic oil and change the oil if the oil becomes black or there is dirt in the oil tank.	every 180 days
2	Max lifting height limit switch	Use proper means to activate the switch and push UP button to check if the carriage stop rising.	every 30 days
3	Roof protection limit switch	Use proper means to activate the switch and push UP button to check if the carriage stop rising	every 30 days

Installation, Operation and Parts Manual

MJ-C10

S/N	Components	Methods	Period
4	Mechanical safety locking unit	Check if mechanical locking hooks can engage or disengage simultaneously by pushing control buttons.	every day
5	Upside pulley and steel cable	Lubricate the pulley and steel cable. Inspect and add more grease when necessary.	every 90 days
6	Slider and its moving tracks	Lubricate the slider and its moving path inside the post. Change the slider when it is over worn.	every 90 days
7	Cylinder connector	Check the hydraulic tightness of oil cylinder connector.	every 90 days
8	Downside pulley and steel cable	Lubricate the pulley and steel cable. Inspect and add more grease when necessary.	every 90 days
9	Lifting adapter	Check if it can screw UP and DOWN smoothly. Add grease onto the swivel when necessary. Inspect the rubber pads and clean off any objects that may cause sliding or damage.	every day
10	Swing arm locking units	Push the UP button to raise the lifting arms and check if four swing arms are locked into position. Add grease in case necessary.	every day
11	Expansion bolts	Check with torque spanner. Screw torque: 63-74b.ft(80-100Nm)	every 90 days
12	Steel cables	Check the synchronization of both carriages and adjust the tightness of the cable if desynchronization is unacceptable.	every day

If users stick to the above maintenance requirements, the lift will always keep a good working condition and its service life could be extended.

Annex 1, Floor plan

Indoor installation only. There must also be a clearance of at least 1 meter between the lifting platform and fixed elements (e.g. wall) in all lifting positions. There must be sufficient space for driving vehicles on and off.

C25 concrete foundation with a minimum thickness of 200mm.

Surface under the base: Horizontal and even (Gradients max. 0.5 %)

Newly built concrete ground must be older than 20days.

All dimensions are in millimeters unless specified otherwise.

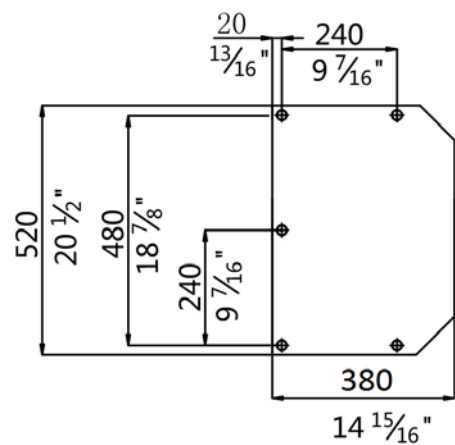
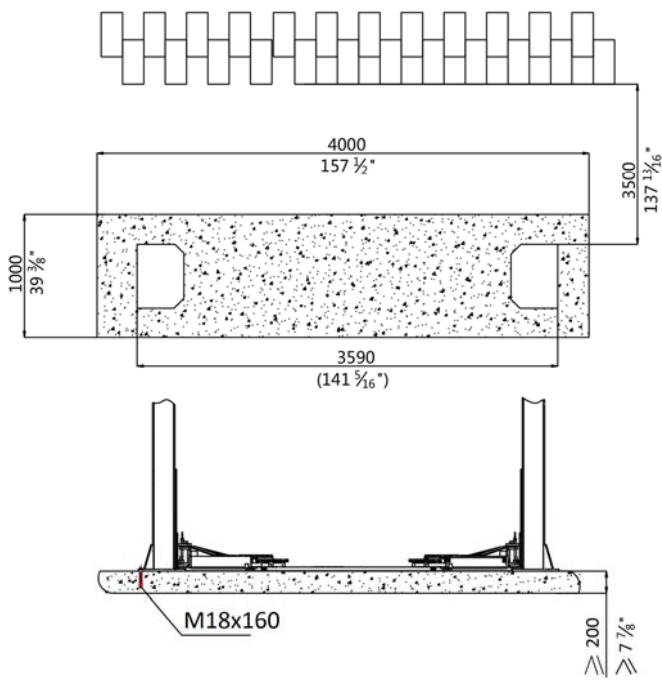
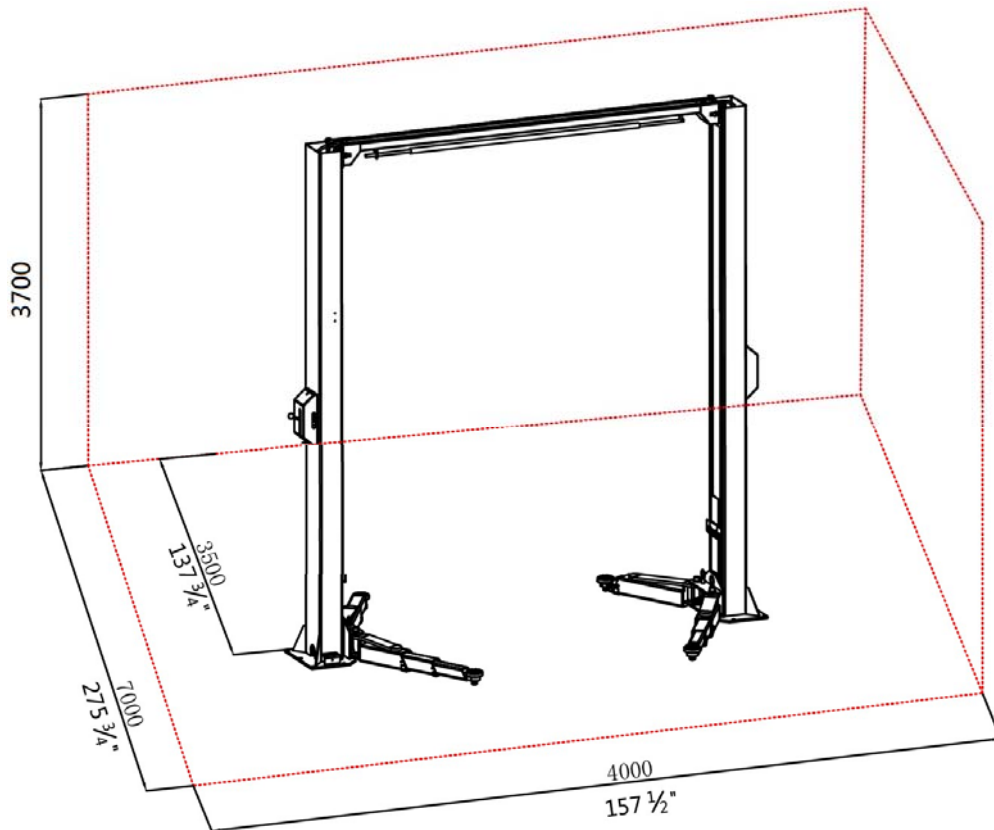

Annex 2, Electrical schemes and parts list

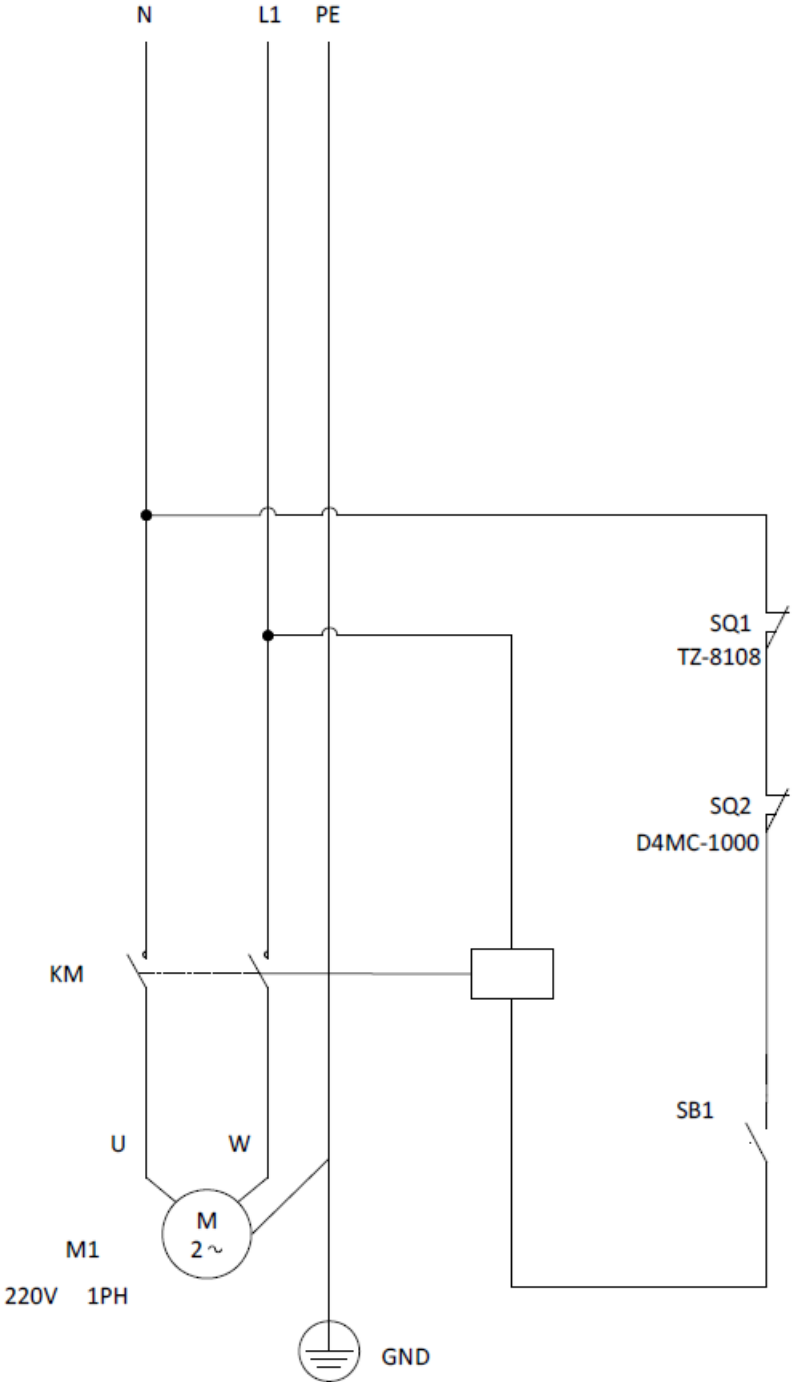

POS.	CODE	Descriptions	Qty
SQ1	320301011	Limit switch	1
SQ2	320301002	Limit switch	1

1Ph wire connection

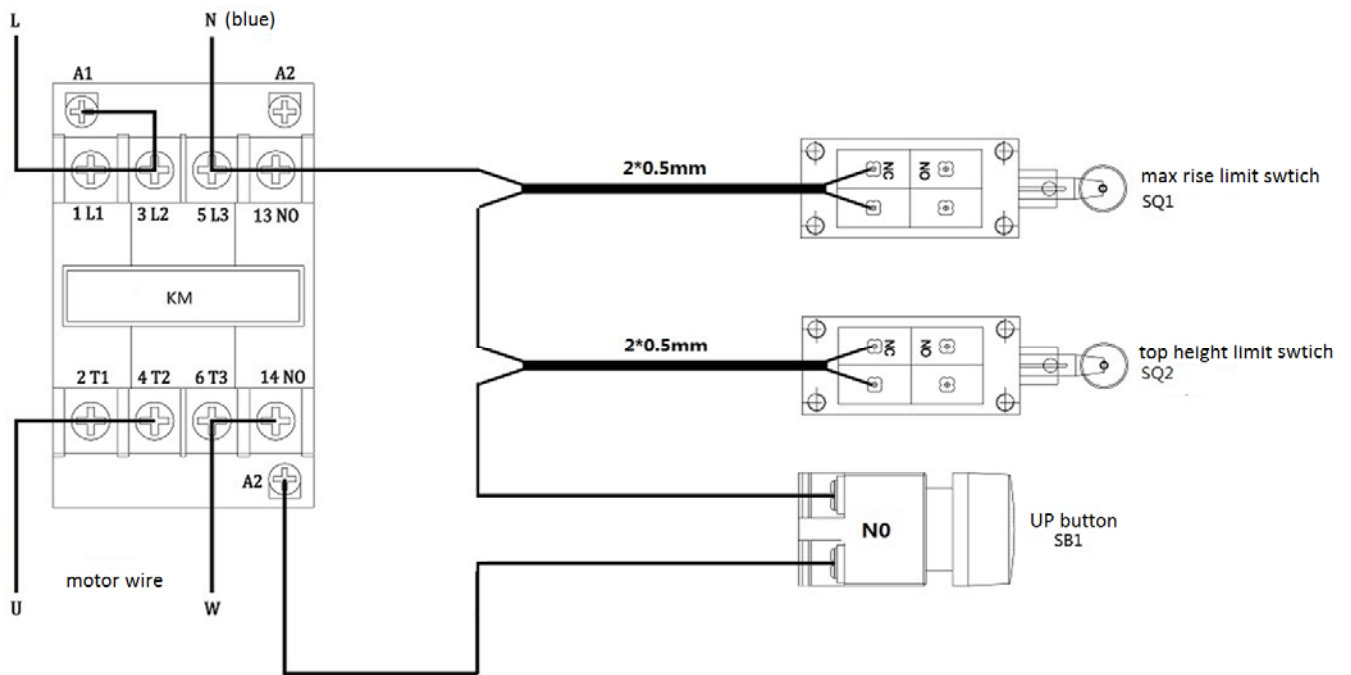

Wire L is going to be fixed with terminals A1, 3L2 and 1L1. Wire N is going to be fixed with terminals 5L3 and 13NO.

Wire U is going to be fixed with terminals 2T1 and 4T2. Wire W is going to be fixed with terminals 6T3 and 14NO.

Annex 3, Hydraulic schemes and parts list

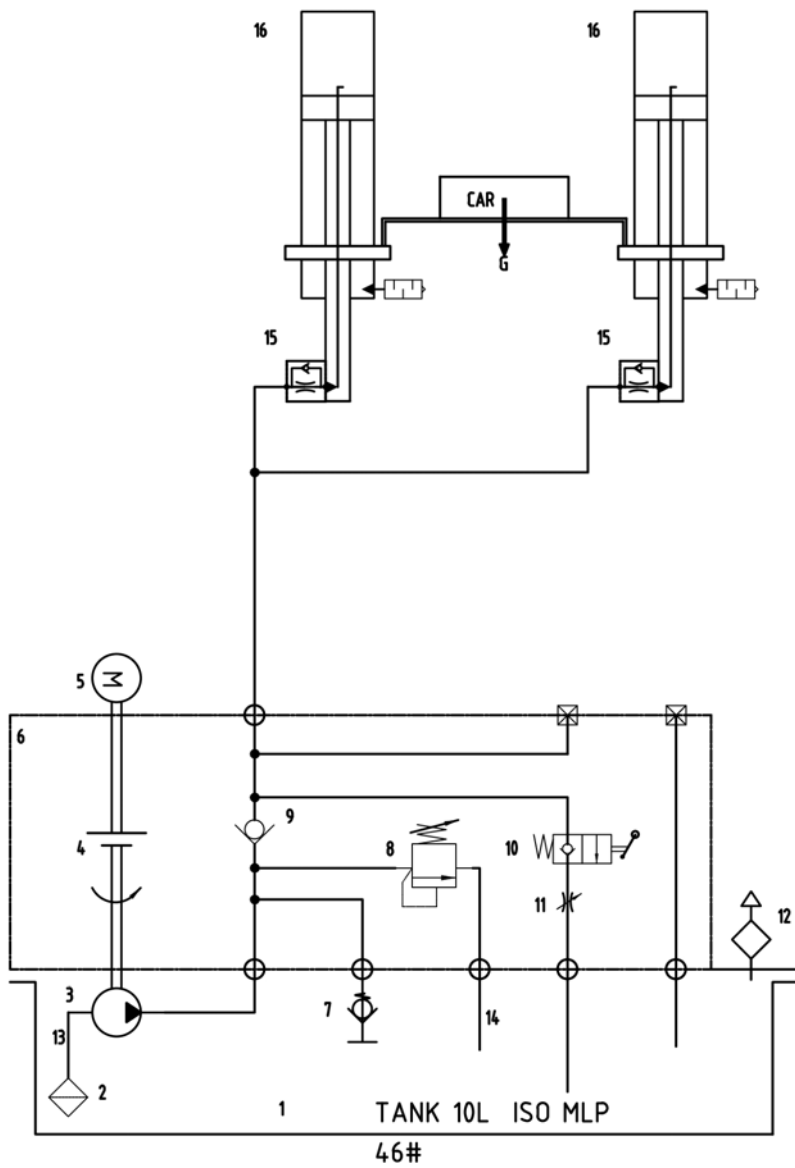

- 1.oil tank
- 2.oil sucking filter
- 3.gear pump
- 4.coupling
- 5.motor
- 6.hydraulic block
- 7.cushion valve
- 8.overflow valve
- 9.single way valve
- 10.manual unloading valve
- 11.flow control valve
- 12.oil tank cover
- 13.oil-sucking pipe
- 14.oil-returning pipe
- 15.composite connector
- 16.oil cylinder

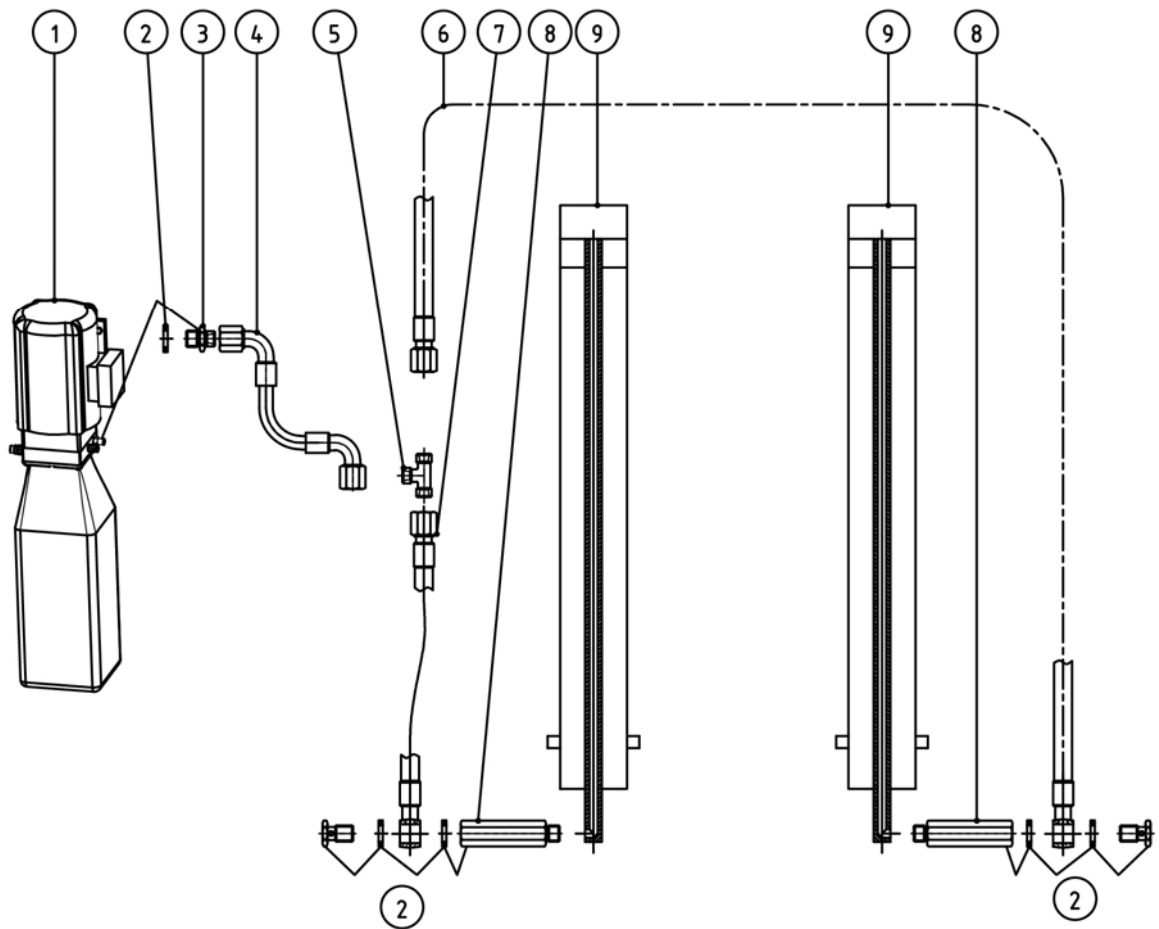

POS.	CODE	Descriptions	Specification	Qty
1	622034300	Power unit	220V-60HZ-1PH-2.5KW-17MPA-10L	1
2	207103019	Composite washer	M14	1
3	310101008	Connector	M14*1.5-G1/4	1
4	624008106	Rubber oil hose	L=430mm	1
5	615006003	Three-way connector	6214E-A4-B4	1
6	624008126	Rubber oil hose	L=9080mm	1
7	624008104	Rubber oil hose	L=1270mm	1
8	615015003	Composite connector	6255E-A7-B7	2
9	615068508	Cylinder	YG5060-38-1600	2

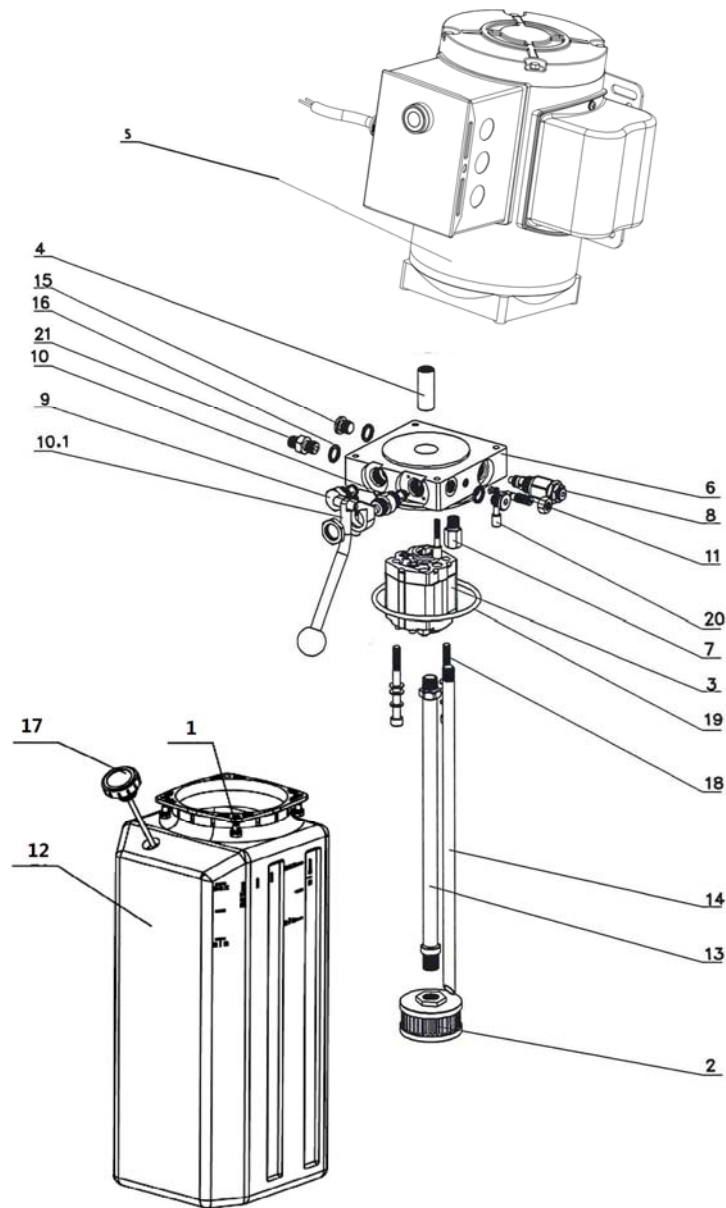

POS.	Code	Description	Specification	Qty
1	202109144	Bolt	M5x18	4
2	330403003	Oil filter	YBZ-E2D311/1-10	1
3	330201006	Gear pump	CBK-F225/CBK-2.5F	1
4	330404015	Coupling	YBZ-E0.963Z0/1-02, 46mm	1
5	320204209	Motor	AM61-3HAM-3BA34R (208-240V,50/60Hz,2.2KW,2850/3450RPM)	1
6	330105017	Hydraulic block	LBZ-T1BK-2	1
7	330301003	Cushion valve	HCF-Z1/4	1
8	330304010	Relief valve	DANRV-08-50	1
9	330302008	Non-return valve	YBZ-E2D311/1-03	1

Installation, Operation and Parts Manual

MJ-C10

POS.	Code	Description	Specification	Qty
10	330303016	Valve spool of the manual valve	YBZ-E2D311/1-02-C	1
11	330313001	Restrictive valve	BL-I2.5	1
12	330405047	Oil tank	SLYX-10L-L-BX	1
13	330401013	Oil sucking pipe	YBZ-SJYG350	1
14	330402006	Oil returning pipe	YBZ-E2D311/1-09	1
15	210101013	Fitting	M 14*1.5	2
16	207103025	Composite washer	13_7X20X1_5	3
17	330502013	Cover	YBZ-BT-M30*2-B	1
18	202109072	Hex socket cylinder head screw	M8x85-GB70_1	2
19	207101098	O seal ring	109*5.3	1
20	202109145	Bolt	YBZ-E3D4H1/10-02	4
21	330600005	Pipe joint	YBZ-F2.51/OOOOT1-02	1
10.1	330303015	Handle of the manual valve	YBZ-E2D311/1-02-B	1

Annex 4, Mechanical exploded drawings and parts list

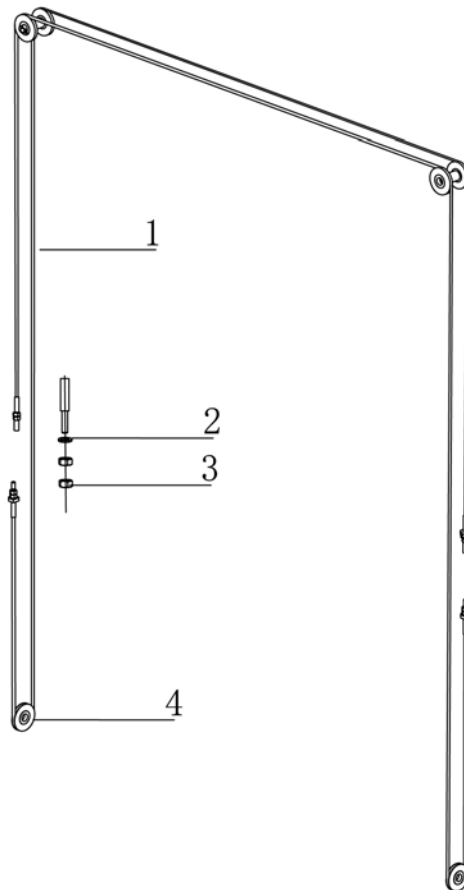

POS.	Code	Description	Specification	Qty
1	615068509	Steel cable	L=9760mm	2
2	203101009	Hex nut	M16-GB6170	8
3	204101009	Flat washer	D16-GB95	4
4	410902109	Pulley	C9Z-A1-B2	2

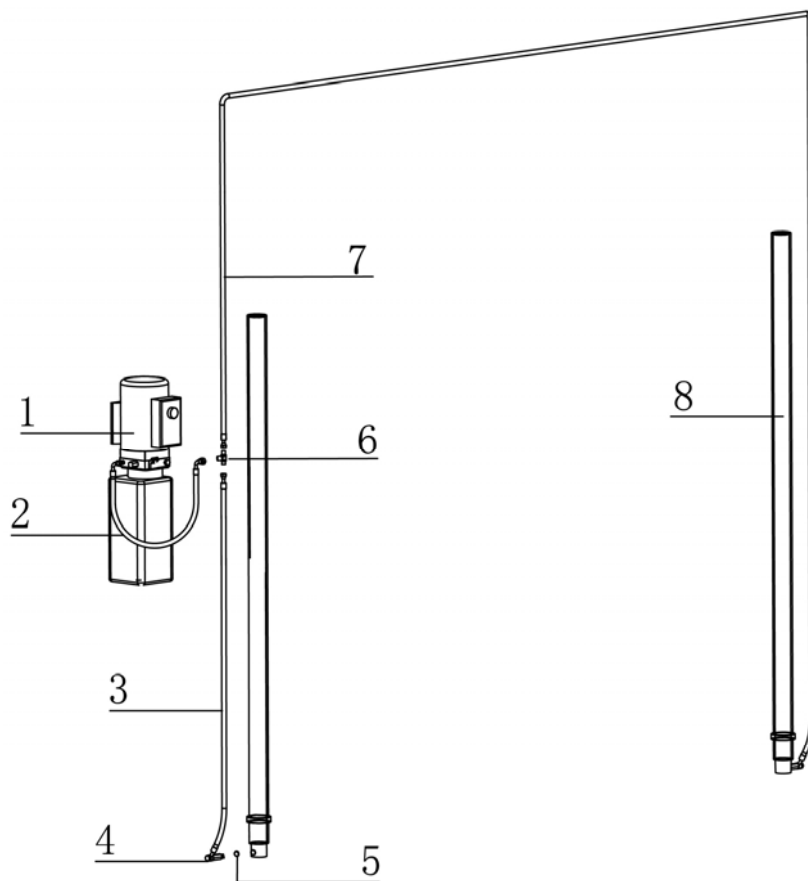

POS.	Code	Description	Specification	Qty
1		Power unit		1
2	624008106	Rubber oil hose	L=430mm	1
3	624008104	Rubber oil hose	L=1270mm	1
4	615015003	Composite connector	6255E-A7-B7	2
5	207103025	Composite washer	13_7X20X1_5	4
6	615006003	Three way connector	6214E-A4-B4	1
7	624008126	Rubber oil hose	L=9080mm	1
8	615068508	Cylinder	YG5060-38-1600	2

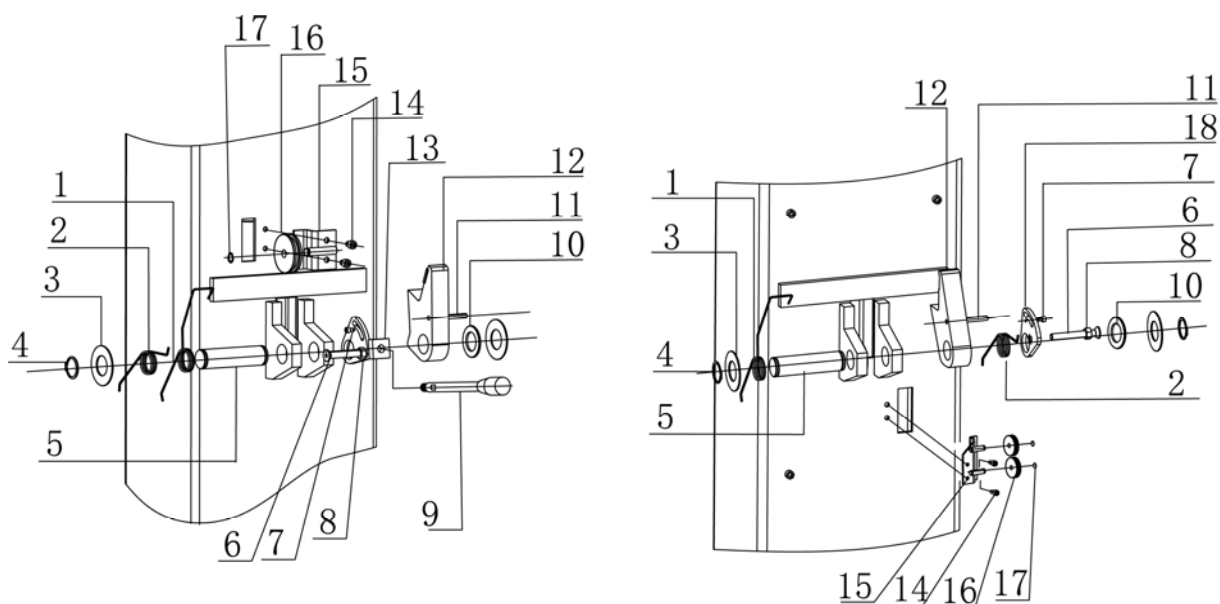

POS.	Code	Description	Specification	Qty
1	410902013	Spring	C9Z-A1-B10	2
2	410902014	Spring	C9Z-A1-B11	2
3	410010031	Washer	6254E-A1-B3	4
4	204301009	Circlip	D25-GB894_2	4
5	410902031	Shaft	C9Z-A1-B6	2
6	202111033	Hex socket flat head screw	M8x65-GB70_3	2
7	202109005	Hex cylinder head screw	M4X6-GB70_1	2
8	203101005	Hex nut	M8-GB6170	4
9	615068400	Handle	C9Z-A1-B12	1
10	420680066	Nylon spacer	25X41X25	2
11	206102013	Post pin	D6X40-GB879	2
12	410902012	Hook	C9Z-A1-B4-C1	2
13	611901420	Release plate	C9Z-A1-B5	1
14	202109017	Hex socket cylinder head screw	M6X8-GB70_1	8
15	614066305	Guiding bracket for lock release device	F10-A5-B1	1
16	420080030	Pulley II	6214DS-A7	5
17	204301001	Circlip	D10-GB894_1	2
18	410540530	Release plate	C12-A1-B5-C1	1

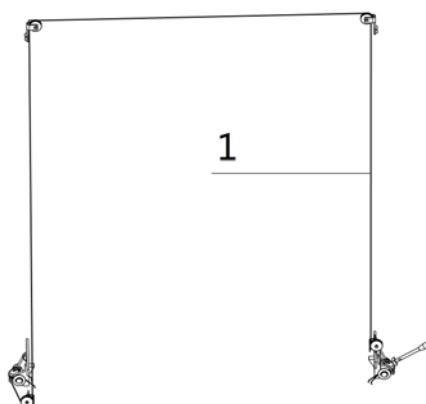

POS.	Code	Description	Specification	Qty
1	208110003	Steel rope	C10Z-A17 (L=9200mm)	1

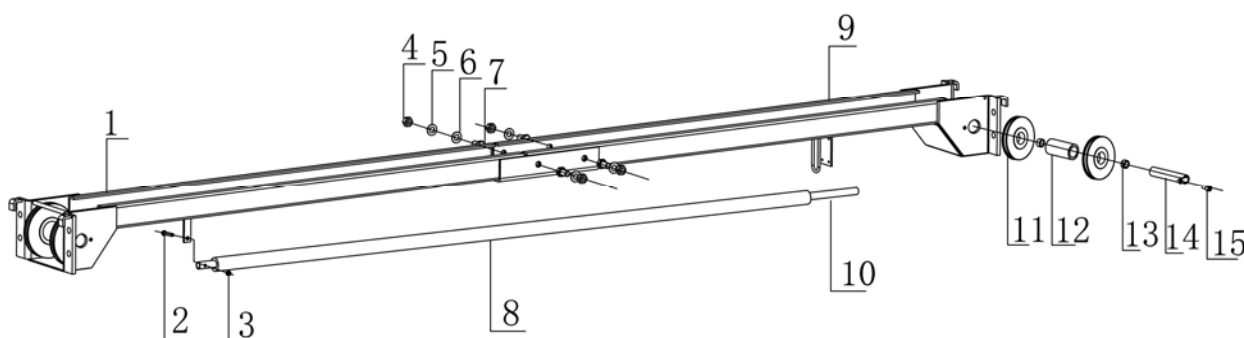

POS.	Code	Description	Specification	Qty
1	614901418	Crossbeam (outside)	C9MV2-A21-B1	1
2	202109024	Hex socket cylinder head screw	M6X35-GB70_1	1
3	203103005	Locking nut	M6-GB889_1	1
4	204101008	Flat washer	D14-GB95	5
5	204201007	Spring washer	D14-GB93	5
6	203101008	Hex nut	M14-GB6170	5
7	201102035	Hex head full swivel screw	M14X30-GB5783	5
8	420060010	Black foam tube	6214E-A21-B3	1
9	614901419	Crossbeam (inside)	C9MV2-A21-B2	1
10	410902124	Long rod	C10ZV2-A21-B2	1
11	410902109	Pulley	C9Z-A1-B2	4
12	410902029	Space sheath	C9Z-A21-B4	2
13	205101101	Bearing	3520-SF-1X	4

14	612054507	Upside pulley shaft	C10S-A21-B3	2
15	202111004	Hex socket flat head screw	M8X12-GB70_3	2

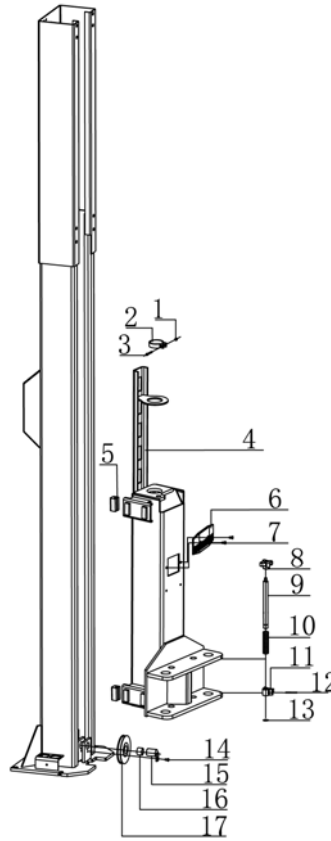

POS.	Code	Description	Specification	Qty
1	203103005	Locking nut	M6-GB889_1	2
2	410170101B	Cylinder orientation ring	6264-A24-B1	2
3	202109096	Hex socket cylinder head screw	M6X40-GB70_1	2
4	614901378	Carriage	C9Z-A3-B1-2	2
5	420680083	Sliding block	C9Z-A3-B5	16
6	420040160	Protective rubber pad	6254E-A2-B6	2
7	202111004	Hex socket flat head screw	M8X12-GB70_3	4
8	203204011	Knob	50XM10	4
9	410902001	Pull rod	6254E-A2-B1-C1-1	4
10	410150121	Pressure spring	6254E-A2-B4	4
11	410901075	Teeth block	6254E-A2-B9	4
12	206102013	Elastic post pin	D6X40-GB879	4
13	204301009	Circlip	D25-GB894_2	4
14	202111004	Hex socket flat head screw	M8X12-GB70_3	2
15	612056001	Shaft for downside pulley	C12-A1-B3	2

Installation, Operation and Parts Manual

MJ-C10

POS.	Code	Description	Specification	Qty
16	205101101	Bearing	3520-SF-1X	2
17	410902109	Pulley	C9Z-A1-B2	2

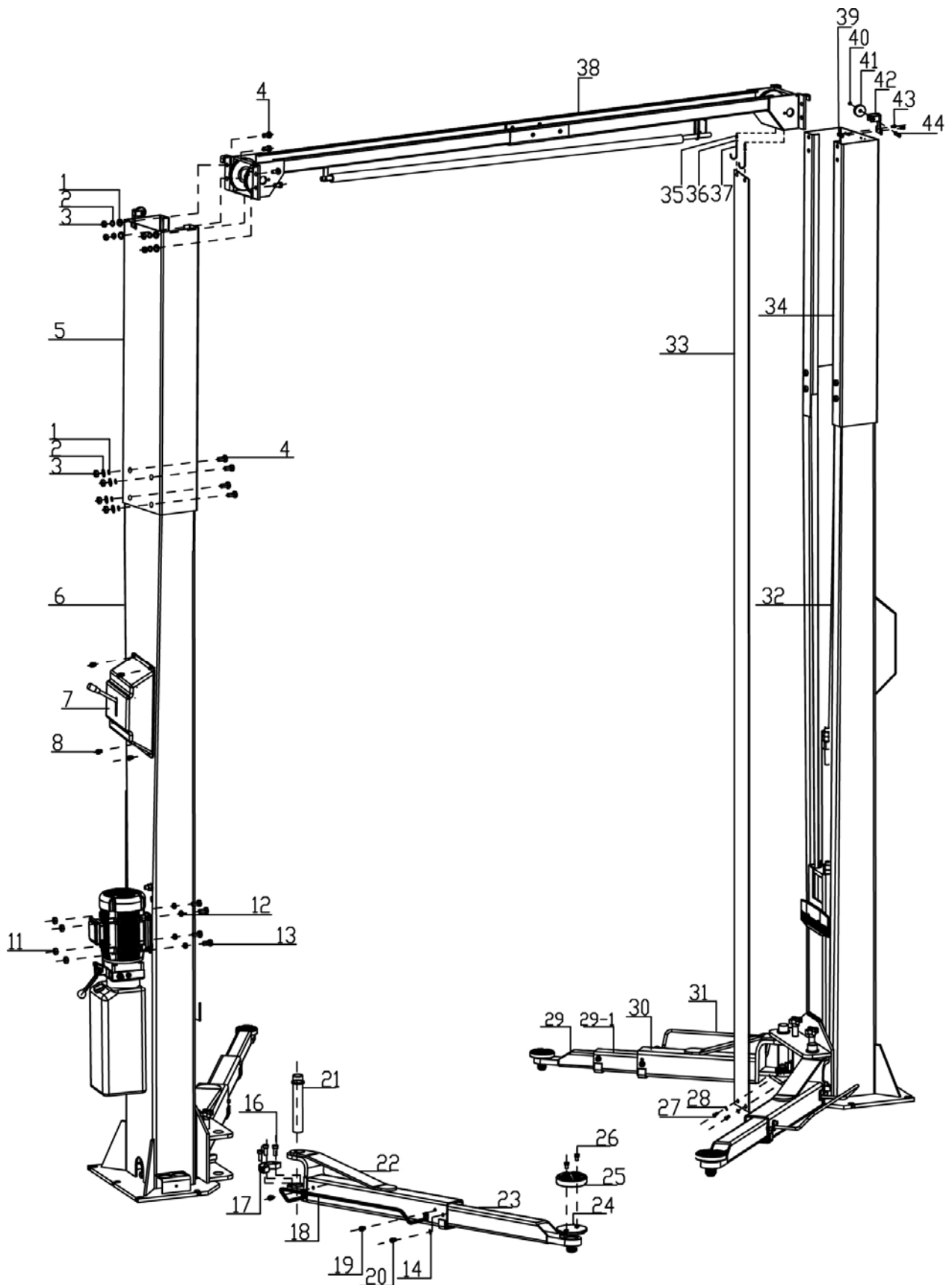

Installation, Operation and Parts Manual

MJ-C10

POS.	Code	Description	Specification	Qty
1	204101008	Flat washer	D14-GB95	8
2	204201007	Spring washer	D14-GB93	8
3	203101008	Hex nut	M14-GB6170	8
4	201102035	Hex head full swivel screw	M14X30-GB5783	8
5	614901542	Extending post for power side post	C9MV2-A5-B1-3500	1
6	614901541	Power side post	C10MV2-A1-B1-3500	1
7	420680096	Protective cover	C9Z-A1-B9-1	2
8	202109017	Hex socket cylinder head screw	M6X8-GB70_1	8
11	203204103	Flange nut	M8-GB6177	4
12	420040010	Anti-shock ring	6254E-A23	4
13	201101103	Bolt	M8X30-GB12	4
16	202109085	Hex socket cylinder head screw (12.9)	M12X30-GB70_1	12
17	410901074	Semicircular teeth block	6254E-A7-B8	4
18	614004014B	Long fender	6254E-A7-B5	2
19	202110018	Hex socket cylinder head screw	M10X12-GB70_1	8
20	202109040	Hex socket cylinder head screw	M10X16-GB70_1	4
21	410049031B	Pin shaft	6254E-A12	4
22	614004005B	Long support arm	6254E-A7-B1	2
23	614901362	Retractable arm	6254E-A7-B3-1	2
24	615004003D	Lifting tray	#N/A	4
25	420040250	Round rubber pad	#N/A	4
26	202111004	Hex socket flat head screw	M8X12-GB70_3	8
27	202101027	Cross socket cap head screw	M6X8-GB818	4
28	204101004	Flat washer	D6-GB95	8
29	614004011C	Retractable arm	6254E-A27-B3	2
29-1	614004009C	Mid arm	6254E-A27-B2	
30	614004007C	Short support arm	6254E-A27-B1	2
31	614004012B	Short fender	6254E-A27-B4	2
32	614901421	The secondary post	C10MV2-A2-B1	1
33	615008007	Protective cloth assembly	C10-A8	2
34	614901543	Extending post for secondary post	C9MV2-A6-B1-3500	1
35	203101004	Hex nut	M6-GB6170	8
36	204101004	Flat washer	D6-GB95	4
37	410010051	Hook for the covering cloth	6254E-A1-B5	4
38	615068409	Crossbeam assembly	C10MV2-A21	1
39	203103006	Hex locking nut	M8-GB889_1	4
40	204301001	Circlip	204301001	4
41	420080030	Pulley II	6214DS-A7	2

POS.	Code	Description	Specification	Qty
42	410060573	Support bracket for the upside pulley	6214DS-A10	2
43	202109029	Hex socket cylinder head screw	M8X20-GB70_1	4
44	410080271	Shaft of the upside guiding wheel	6214DS-A10-B3	2

Optional height-extension adapter and holder

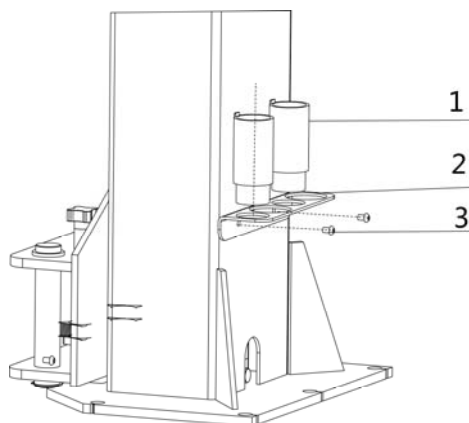

POS.	CODE	Description	Specification	Qty
1	612004003B	Height-extension adapter	6254E-A11	4
2	410901744	Holder	6254E-A1-B1-C6-V0	2
3	202110004	Hex socket button head screw	M8X12-GB70_2	4