

AUTOMATIC TYRE CHANGER

INSTRUCTION MANUAL

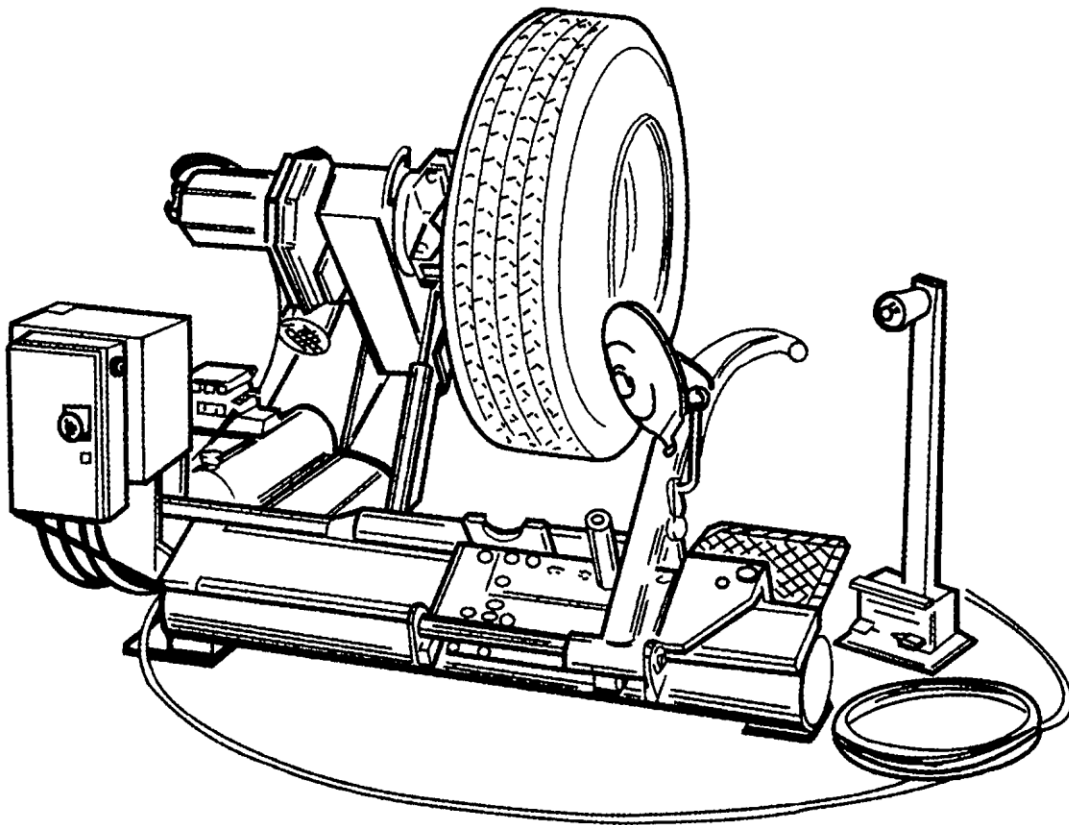

1 GENERAL INFORMATION

Tyre changer has been specifically designed to demount high-speed bus and truck tyres with rims form 14"to 26"and a maximum 1600mm diameter

Any other use is improper and therefore not authorized.before beginning any kind of work on or with this machine,carefully read and understand the contents of these operating instructions.

Shall not liable for any injury to persons or damage to things caused by improper use of this machine.

keep this manual near the machine and consult it as needed during operations.

2 TECHNICAL DATA

Pump motor	1.5KW
Gear-box motor	1.8KW
Handles rim form	14"-26"
Max. wheel diameter	1600mm
Max. wheel width	780mm
Weight(with standard accessories)	570kg
Acoustic pressure level(at work)	LPA<70dB(A)

3 GENERAL SAFETY REGULATION

The use of this machine is reserved to specially trained and authorized personnel.

Any unauthorized changes or modifications to the machine,in particular to its electrics system,relieve form all liability.

Removing or tampering with the safety devices installed on this machine is in violation of European safety Regulations.



Any work, however minor, on the electric system must be done exclusively by professionally qualified personnel.

4 SAFETY DEVICES

Tyre changer has a number of safety devices designed to guarantee the utmost operator safety:

1. **Check valve on the spindle opening hydraulic line**(inside the swivel connector, see fig.B/1).This prevents the wheel form falling form the spindle if the hydraulic is accidentally broken.
2. **pilot operated dual seal check valve**(see Fig.B/2)
This prevents the spindle carrier arm from dropping if the hydraulic circuit accidentally breaks.
3. **Pressure relief valve factory set at 130 bar $\pm 5\%$** (see Fig. B/3).
This limits the pressure in the hydraulic circuit and ensure correct operation of the plant.
4. **pump motor overload cut-out**(inside the electric enclosure).
This cuts in if the motor overheats to prevent it from burning out.
5. **Mechanical tool arm tip lock device** (see Fig.B/4).

Prevents the arm form being moved to its “non-working position”if the tool has

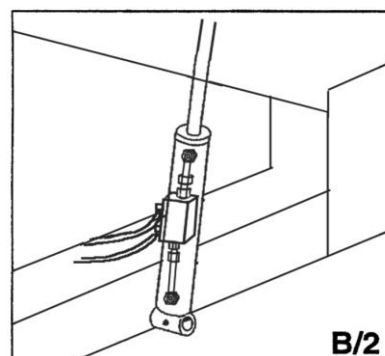
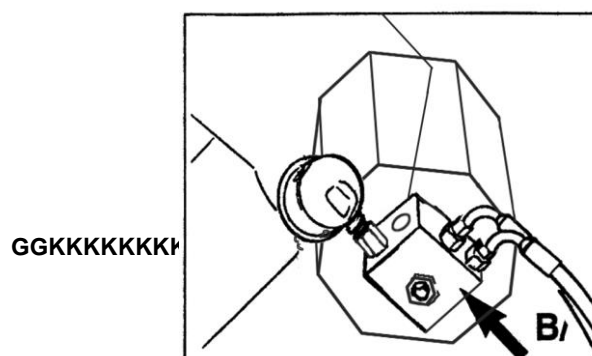

been removed.

CAUTION!

Removing or tampering with safeties is in violation of European Safety Regulations and relieves manufacturer of any and all liability for injury to persons to damage to things caused or referable to such acts.

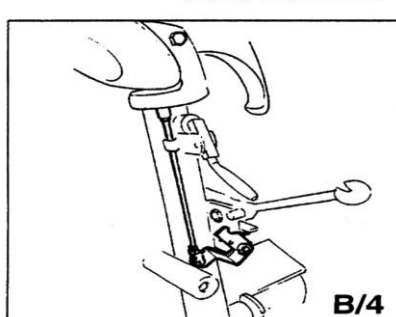
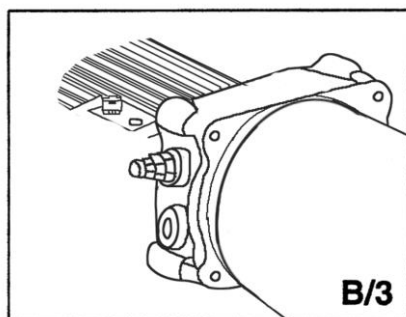

U
T
I
L
I
T
Ä
T
Z
G
E
S
T

5 TRANSPORT

Depending on customer request, the machine is delivered in 3 packing versions:

1-in a wooden crate with pallet

2-fixed to a pallet

3-no packing

In all cases the machine is protected by a plastic covering.

In the first and second case, the machine must be handled with a fork-lift truck with the forks positioned as shown in the figure.

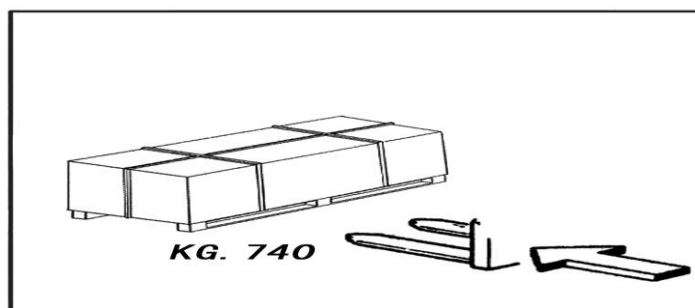

6 UNPACKING

Once the packing material has been removed, check the machine visually for any signs of damage.

Keep the packing materials out of the reach of children as they can be a source of danger.

N.B.: Keep the packing for possible future transport.

7 INSTALLATION INSTALLATION PLACE

Choose the place the machine is to be installed in compliance with current work place safety regulations.

The floor should not be broken or uneven so that the machine will be stable and the platform rollers can move freely.

If the installation is outdoor, it must be protected by some kind of roofing against rain.

The following work environment conditions are applicable: Relative humidity : form 30-95% without condensation; Temperature: form 0-55°C.



ATTENTION!

WORKPLACE REQUIREMENTS

Maximum machine space requirements are 1950×1600mm with a minimum distance from walls as shown in the diagram.

Caution! These measurements are also the tyre changers working range. persons other than specially trained and authorized operators are expressly forbidden to enter this area.

Position the tyre changer lifting it with the specific bracket (1, fig.A) with the tool carrier arm (2, Fig.A) lowered all the way. the spindle (3, Fig.A) closed and the tool carrier slide (4, Fig.A) at its stop close to the arm.

It is not essential to anchor the machine to the floor however, the floor must be

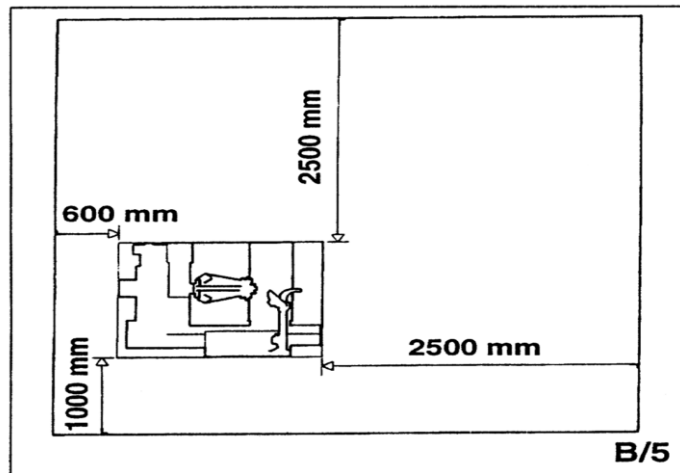

smooth and permit the platform rollers to move freely.

ELECTRIC HOOK UP

Before making any electric hook up, check to be certain that the mains voltage corresponds to that stamped on the voltage tag (attached to the cord near the tyre changer's plug).

It is absolutely essential that:

- the system is equipped with a good grounding circuit.**
- The machine is connected to a power supply line circuit breaker set for 30 mA.**
- The current instate is adequately protected against overcurrents with fuses or automatic switch with rated values as shown in the table.**

power supply	Rated current	
	Fuse	Switch
380v-3ph-50/60Hz.	10A	16A

Note the required power draw as highlighted on the data plate fixed to the tyre changer. Check to make sure the shop electric wiring circuit is dimensioned sufficiently to carry this.



Work on the electric system, even if minor, must be done exclusively by professionally qualified personnel

Manufacturer shall not be liable for any injury to persons or damage to things caused by failure to comply with these regulations and can cancel warranty coverage.

SENSE OF ROTATION CHECKS

Connect the machine to the mains, switch "ON"(5,fig.B/7)and check that the gearbox motor rotation corresponds to the indicating arrow(6,fig.B/6).

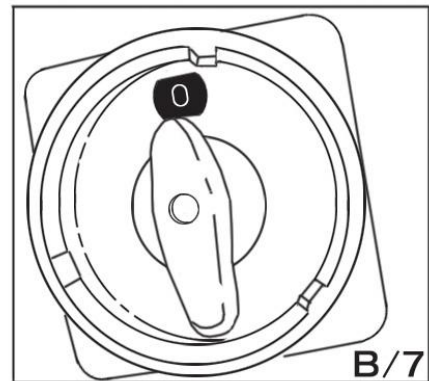
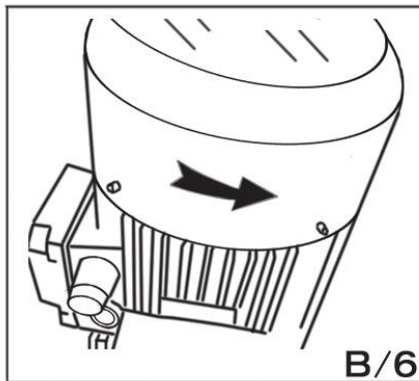

8 IDENTIFYING WARNING SIGNALS

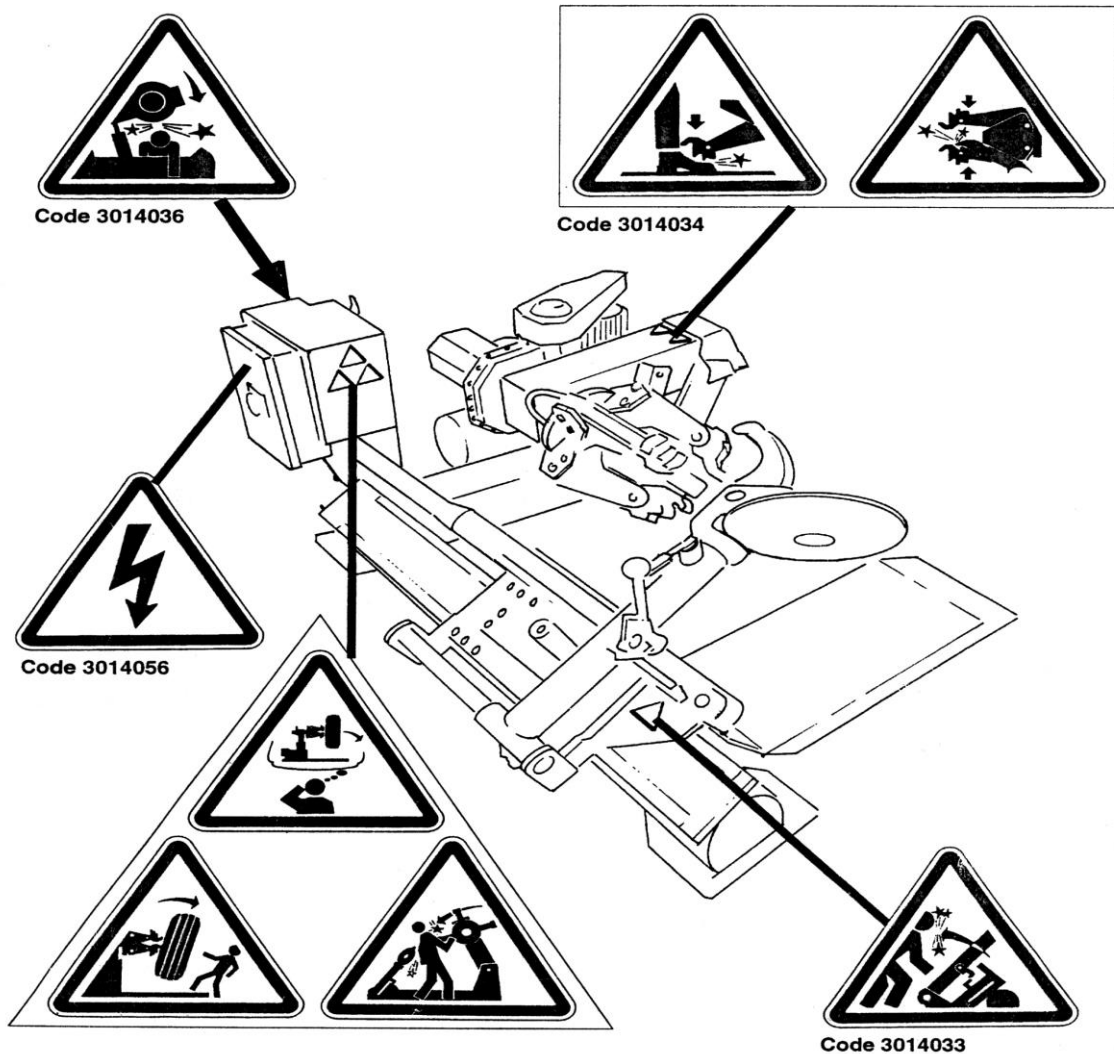

WARNING!



Unreadable and missing warning labels must be replaced immediately.

Don't interpose any object witch could prevent the operator

9 IDENTIFICATION OF CONTROL

The mobile control center(**fig.c**)enables the operator to work at any position around the machine .on this mobile control center the following controls are located:

-**The lever(8,fig.c)**which in position **a** lifts the chuck arm and in position **b** lowers it; in position **c** moves the tool holder arm and in position **d** moves them away.(Note:in order to memorise this operation, there is a hole in the lever guard corresponding to position **c**).

-**The chuck switch(9,fig.c)**when moved upwards, opens the arms of the self-centering chuck (LOCKING),and when moved down, close the arm of the self-centering chuck(UN-LOCKING).

-**The pedal(10,fig.c)**when pressed on the left or right side rotates the self-centering chuck in the same direction as shown by the arrows placed on the foot pedal.

NOTE:all the controls are very sensitive and small movements of the .machine can be done with precision.

The tyre changer also has:

Lever(15,Fig.D) to tip the tool carrier arm (**14,Fig.4**) from its work to its non-working position and vice-versa.

Handle(19,Fig.D) that permits alternative use of the bead-breaking disk(**17,Fig.D**)or the hooked tool(**18,Fig.D**).

10 WORKING POSITION

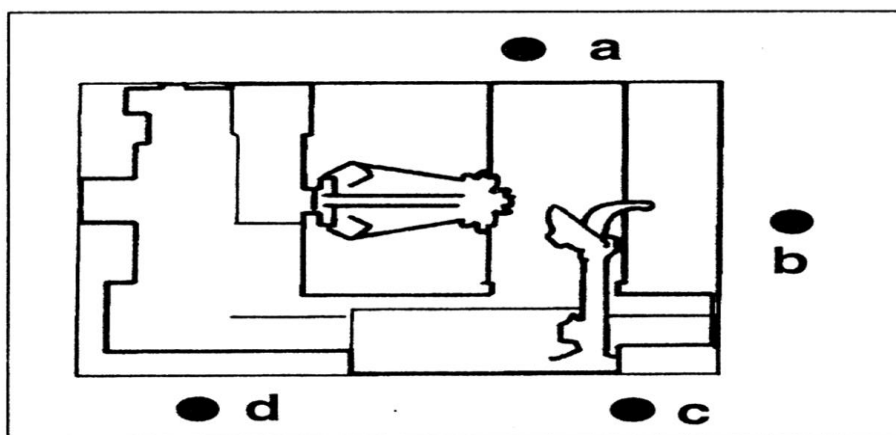

The diagram shown here illustrates the various working positions

(A,B,C,D)referred to in the following pages describing how to use the tyre changer.

Use of these positions ensures greater precision, speed and safety for those using the machine.



Lifting arm lift or lower and hydraulic chuck open or close, there is always a potential for crushing anything in its movement range. Always work from the position given in the instructions keep well out of the working range.

11 CORRECT OPERATION CHECKS

Before using the tyre changer, a number of checks should be made to ensure it works correctly.

CAUTION! The operations described here should be done with the tool carrier arm in its non-working position.

First use lever(15,Fig.d) to tip the arm to this position.



CAUTION!

Do not move your face close to the tool carrier arm when you

1) move the joystick(8,Fig.c)up (a):the spindle carrier arm (2,Fig.a) should lift ;move the joystick down (b):the arm should lower.

move the joystick towards the left (C):the tool carriage and the mobile platform(13,Fig.D) should move towards the spindle(3,Fig.A);move the joystick towards the right (d) the carriage and platform should move away from the spindle.



DANGER!

When the spindle carrier arm is lowered. There is always a potential for crushing anything in its movement range. Always work from the position given in the instructions keep well out of the working range of the various moving arms

2) Turn switch lever(9, Fig.C) towards the top: the spindle arm should open;
 (2, Fig. A) move the lever down and the spindle arms should close.



DANGER!

When the spindle arms open or closed, there is always a potential for crushing anything in their movement range.

Always work from the position given in the instru-

3) depress the right pedal(10, Fig.C): the spindle(2, Fig.A) should turn clockwise;
 depress the left pedal: the spindle should turn anticlockwise.

4) check to be certain the hydraulic circuit is working correctly:

- move switch lever(9, Fig.c) towards the top until the spindle arms are fully extended.

- hold the switch lever in this position (Top) and check if the pressure shown on the gauge on the swivel fitting is 130 bar 5%.

If the pressure shown is not as indicated here, do not use the tyre changer and call your nearest tongguang assistance center.

12 USE



WARNING!

During all operations, keep hands and the other parts of the body as possible from moving parts of the machine.

Necklaces, bracelets and too large clothes can be dangerous for

LOCKING THE WHEEL



WARNING!

In locking the wheel, make sure that clamps are properly positioned on the rim, so as to prevent the tyre from falling.



1) take the mobile control unit to work position B.

3) Operating from the mobile control center, move the sliding table (13,fig.D) away from the self-centering chuck and place the wheel in vertical position on the sliding table.

4) Continuing to operate from the mobile control center, lift or lower the arm in order center the self-centering chuck(3,fig.a) relative to the rim.

5) With the jaws(22,fig.A) in the closed position, move the wheel on the sliding table to the self-centering chuck. Operate the chuck switch

Always remember that the safest locking is on the central flange.

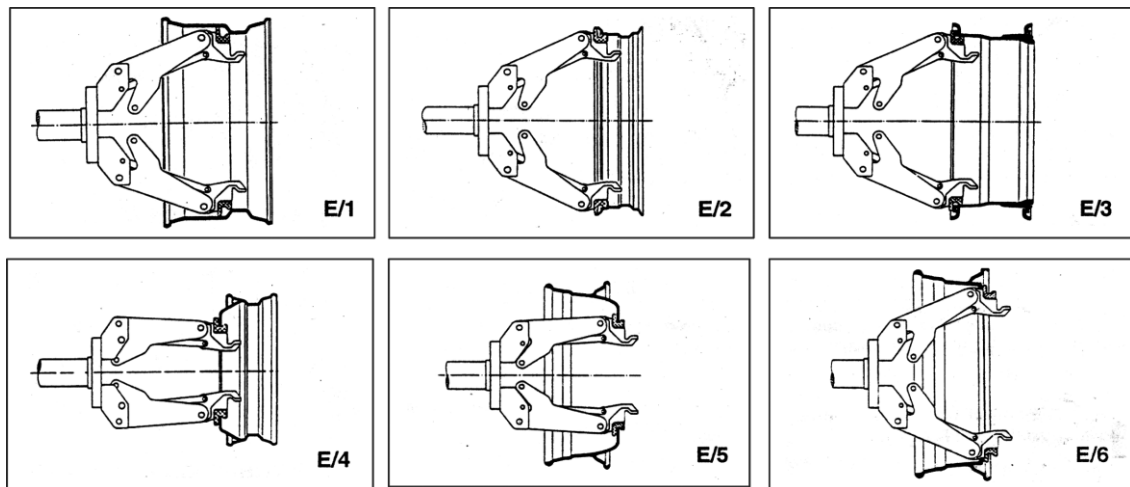

N.B.for rims with channel, clamp the wheel so that the channel is near the outside of the rim (fig.E/1)

DANGER!



This operation can be extremely dangerous.

Do it manually only if you are certain you can keep the wheel balanced.



DANGER!

Do not very the area with a wheel clamped on the tyre changer

TUBELESS AND SUPERSINGLE WHEELS BEAD BREAKING

- 1) Look the wheel on the self-centering chuck, as previously described, and ensure that the tyre is deflated.
- 2) Take the mobile control unit to work position C.
- 3) LOWER THE TOOL-HOLDER ARM (14, Fig.F) into its working position and allow it to lock.

- 4) Operating from the mobile centre, rotate the wheel until the outside of the rim skims the bead-breaker disk(fig.F).
- 5) Rotate the wheel and at the same time, advance the bead-breaker plate with small forward movements following the profile of the rim, with the plate.
- 6) Continue until the first bead is fully detached. To facilitate this operation, lubricate the bead and the edge of rim with tyre lubricant whilst the wheel is rotated.



DANGER!

Always check to be certain that the arm is correctly hooked to



DANGER!

The bead breaker disk must **NOT** be pressed against the rim but against the bead.

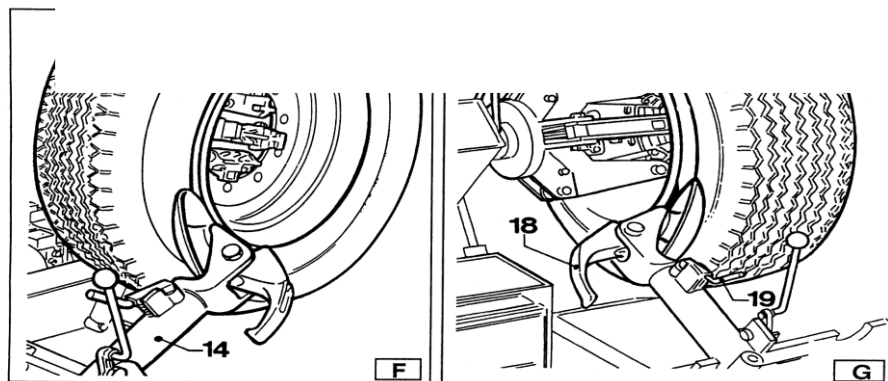

CAUTION!

To avoid all risk, lubricate the beads turning the wheel **CLOCKWISE** if you are working on the outside plane and

Remember that the stronger the tyre's adherence to the rim. the slower must be the disk's penetration.

- 7) Bring the tool carrier arm (14, Fig.F) back from the edge of the rim. Release the hook, raise the arm to its non-working position, shift it and rehook it in its second work position (Fig.G).

8) Push the double headed tool lever (19, Fig.G) and turn the head 180° until it locks automatically.

Then slide the tool-holder arm along the sliding table and lock it in position.



DANGER!

Do not hold your hands on the tool when you bring it back to its work position. Your hand(s) could be trapped between the tool



9) Take the mobile control unit to work position D.

Repeat the operation previously described until the second bead is completely broken.

N.B.: During the bead breaking. The claw (18, Fig.G) can be lowered so that it is out of the way.

DEMOUNTING

Tubeless tyres can be demounted in two ways:

1) If the tyre is not difficult to demount, once the beads have been loosened, use the bead disk to push against the inside plane of the tyre until both beads come off the rim (see Fig.H)

2) With supersingle or very hard tyres the procedure described above cannot be used. The hook tool will have to be used as follows:

- Transfer the tool carrier arm to the outside plane of the tyre.



Take the mobile control unit to work position C.

- Rotate the wheel and at the same time move the hook tool forward inserting it between rim and bead until it is anchored to the bead (see Fig.I)

- Move the rim 4-5 cm from the tool taking care that it does not unhook from the bead.

-Move the hook tool towards the outside until the red reference dot is by the outside edge of the rim.



Take the mobile control unit to work position B.

-Insert lever BL(17, Fig.I) between rim and bead at the right of the tool.

-Press down on the lever and lower the wheel to bring the edge of the rim about 5 cm from the hooked tool.

-Turn the wheel anticlockwise pressing down on lever BL until the tool bead is completely off.

-Move the tool carrier arm to its non-working position and then move it to the inside plane of the wheel.



Take the mobile control unit to work position D.

-Turn the hook tool 180° and insert it between rim and bead(see Fig.L). Move it until the bead is by the edge of the rim (best to do this with the wheel turning).

-Move the rim about 4-5 cm from the tool making sure the hook does not detach from the rim.



Take the mobile control unit to work position B.

-Move the hook tool so that its red reference dot is about 3 cm inside the rim.

-Insert lever BL(17, Fig.I) between rim and bead at the right of the tool.

-Press down on the lever and lower the wheel to bring the edge of the rim about 5 cm from the hooked tool. Turn the wheel anticlockwise pressing down on lever LA until the tyre comes completely off the rim.

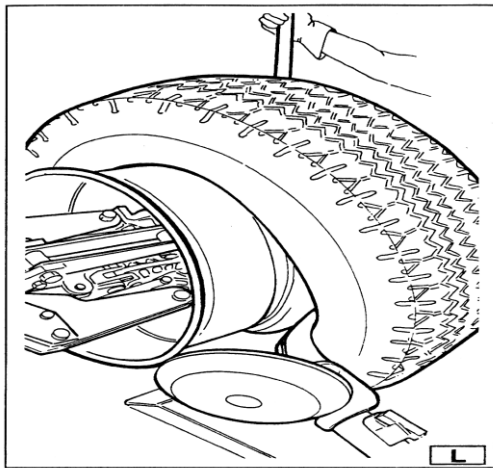
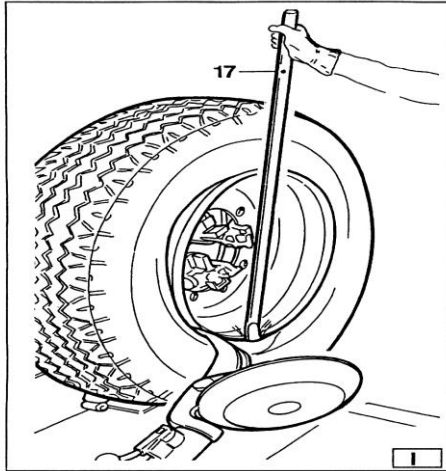

DANGER!

When the beads come off the rim, the tyre will fall. Check to make sure there are no bystanders in the work area

MOUNTING

Tubeless tyres can be mounted using either the **bead breaker disk** or the **hook tool**. If the tyre is not problematic, use the bead loosener disk. If the tyre is very rigid, the hook tool must be used.

TYRE MOUNTING WITH THE DISK

Follow these steps:

-
- 1) If the rim has been removed from the spindle, put it back on the spindle as described in the section on “CLAMPING THE WHEEL”
 - 2) Lubricate both beads and the rim with tyre manufacturer recommended lubricant.
 - 3) Attach the RP clip to the outside edge of the rim at the highest point(see Fig.M).



CAUTION!

Take the mobile control unit to work position B.



- 4) Put the tyre on the platform and lower the spindle (make sure the clip is at the high point).
- 5) Lift the rim with the tyre hook to it and turn it anticlockwise about 15-20 cm. The tyre will be positioned tilted across the rim.



Take the mobile control unit to work position C.

- 6) Position the bead loosener disk against the second bead of the tyre and turn the spindle until the clip is at the low point(at 6 o'clock)
- 7) Move the disk away from the wheel.
- 8) Remove the clip and replace it at 6 o'clock outside the second bead(see Fig.N).
- 9) Turn the spindle clockwise 90° to bring the clip to 9 o'clock.
- 10) Move the disk forward until it is about 1-2 cm inside the edge of the rim. Begin to turn the spindle clockwise checking to make sure that, with a 90° turn, the second bead begins to slip into the center well.
- 11) When the bead is fully mounted, move the tool away from the wheel, tip it to its non-working position and remove the clip.

12) Position the platform under the wheel, lower the spindle until the wheel rests on the platform.



Take the mobile control unit to work position B.

13) Close the arms of the spindle completely. Support the wheel to prevent it falling off.



DANGER!

This operation can be extremely dangerous. Do it manually only if

14) Move the platform to remove the wheel from the spindle.

15) Remove the wheel.

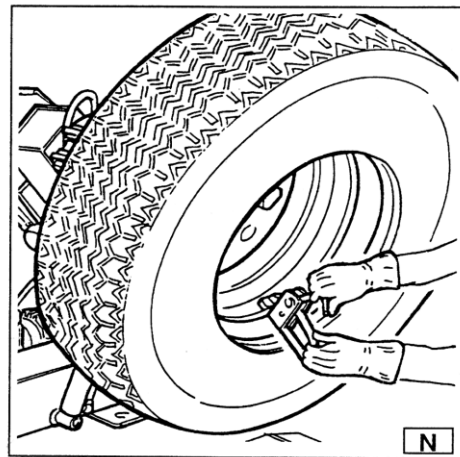
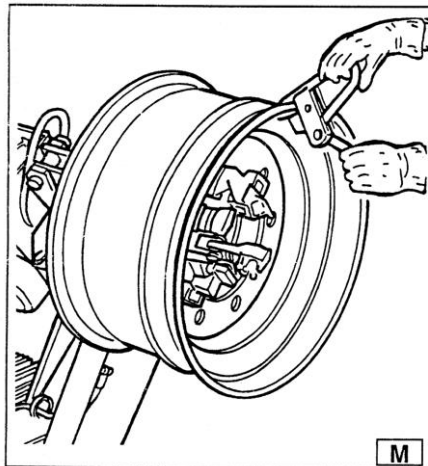

NB: If the tyre permits it, the operation described above can be speeded up by mounting both beads at the same time:

-Follow the steps described under points 1,2,3,4 described above but instead attaching the clip to just the first bead (refer to point 4) clip it to both.

-Lift the rim with the tyre hooked to it and turn it anticlockwise 15-20 cm (clip at 10 o'clock).

-Follow the steps described in points 10,11,12,13,14,15 above.

MOUNTING WITH THE HOOKED TOOL

- 1) Follow the steps described in points 1,2,3,4,5 for mounting with the disk.
- 2) Move the tool carrier arm to its non-working position. Move it to the inside plane of the tyre and rehook it at this position.
- 3) Check to make sure the hook tool is positioned on the wheel side. If not, press lever(19, Fig.D) and turn it 180°.



Take the mobile control unit to work position D.

- 4) Move the tool forward until the red reference dot is lined up with the outside edge of the rim and about 5 mm from it (see Fig.O).

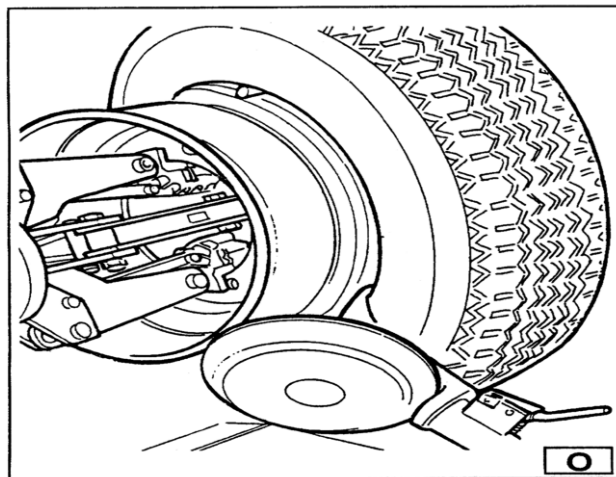

Take the mobile control unit to work position C.

- 5) Move to the outside of the wheel and check the exact position of the tool visually and adjust it as needed. Then turn the spindle clockwise until the clip is at the bottom (6 o'clock). The first bead will be on the rim.
- 6) Remove the clip.



Take the mobile control unit to work position D.

- 7) Remove the tool from the tyre.

- 8) Move the tool carrier arm to its non-working position. Move it to the outside plane of the tyre and rehook it in this position.
- 9) Turn the tool 180° with lever(19, Fig.D).
- 10) Attach the clip at the bottom (6 o'clock) outside the second bead (see Fig.N)



Take the mobile control unit to work position C.

- 11) Turn the spindle clockwise to about 90° (clip at 9 o'clock).
- 12) Bring the tool forward until the red reference dot is lined up with the outside edge of the rim and about 5 mm from it. Begin to turn the spindle clockwise and check if, after about 90° of rotation the second bead has started to slip into the center well. Continue turning until the clip is at the bottom (6 o'clock). The second bead will now be mounted on the rim.
- 13) Follow the steps described in points 11, 12, 13, 14, 15 for mounting with the disk since this will ensure that the wheel is removed correctly from the machine.

TUBED WHEELS BEAD BREAKING

WARNING: Unscrew the bush which fixes the valve when deflating the tyre so that the valve, coming in the inside of the rim, is not an obstacle during bead breaking.

Follow all the steps described previously for bead breaking tubeless tyres.

With tubed tyres, however, stop disk movement as soon as the bead has loosened to avoid damaging the tube inflation valve.

DEMOUNTING



Take the mobile control unit to work position C.

- 1) Tip the tool carrier arm (**14, Fig.D**) to its non-working position. Move it to the outside plane of the wheel and rehook it in this position.

-
- 2) Rotate the wheel and at the same time move the hook tool(18, Fig.D) forward inserting it between rim and bead until it is anchored to the tool.
 - 3) Move the rim 4-5 cm from the tool taking care that it does not unhook from the bead.
 - 4) Move the hook tool towards the outside until the red reference dot is by the outside edge of the rim.



Take the mobile control unit to work position B.

- 5) Insert lever BL(see Fig.P) between rim and bead at the right of the tool.
- 6) Press down on the lever and lower the wheel to bring the edge of the rim about 5 cm from the hooked tool.
- 7) Turn the wheel anticlockwise pressing down on lever BL until the bead is completely off.
- 8) Move the tool carrier arm to its non-working position. Lower the spindle until the tyre is pressed down against the platform. As the platform is moved slightly towards the outside, the tyre will open a little and thus create enough space to remove the inner tube.
- 9) Remove the inner tube and lift wheel back up.



Take the mobile control unit to work position D.

- 10) Move the tool carrier arm to the inside plane of the tyre, turn the hook tool 180° and lower the arm to its work position. Insert it between rim and bead and move it until the bead is by the form edge of the rim(best to do this with the wheel turning).
- 11) Move the rim about 4-5 cm from the tool making sure the hook does not detach from the rim.



Take the mobile control unit to work position B.

- 12) Move the hook tool so that its red reference dot is about 3 cm inside the rim.
- 13) Insert lever BL between rim and bead at the right of the tool (see Fig.Q).
- 14) Press down on the lever and lower the wheel to bring the edge of the rim about 5 cm from the hooked tool. Turn the wheel anticlockwise pressing down on lever BL until the tyre comes completely off the rim.

**DANGER!**

When the beads come off the rim, the wheel will fall. Check to make sure there are no by-standers in the work area.

MOUNING

- 1) If the rim has been removed from the spindle, put it back on the spindle as described in the section on "CLAMPING THE WHEEL".
- 2) Lubricate both beads and the rim with tyre manufacturer recommended lubricant.
- 3) Attach the RP clip to the outside edge of the rim at the highest point (see Fig.R).

**CAUTION!**

Take the mobile control unit to work position B.

- 4) Put the tyre on the platform and lower the spindle (make sure the clip is at the high point) to hook the first bead on the clip.
- 5) Lift the rim with the tyre hook to it and turn it anticlockwise about 15-20 cm. The tyre will be positioned tilted across the rim.

-
- 6) Move the tool carrier arm to its non-working position. Move it to the inside plane of the tyre and rehook it in this position.
 - 7) Check to make sure the hook tool is positioned on the wheel side. If not, press lever(19, Fig.D) and turn it 180°.



Take the mobile control unit to work position D.

- 8) Move the tool forward until the red reference dot is lined up with the outside edge of the rim and about 5 mm from it (see Fig.S)



Take the mobile control unit to work position C.

- 9) Move to the outside of the wheel and check the exact position of the hook visually and adjust it as needed. Then turn the spindle **clockwise** until the clip is at the bottom (6 o'clock). The first bead will be on the rim. Remove the clip.



Take the mobile control unit to work position D.

- 10) Remove the tool from the tyre.
- 11) Move the tool carrier arm to its non-working position. Move it to the outside plane of the tyre.
- 12) Turn the tool 180° with lever(19, Fig.D)



Take the mobile control unit to work position B.

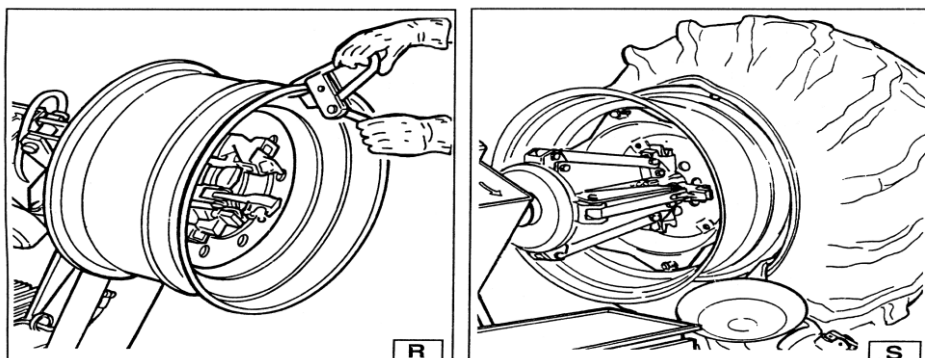

- 13) Turn the spindle until the valve hole is at the bottom (6 o'clock).
- 14) Move the platform (4 Fig. A) under the wheel and lower the spindle until the tyre is pressed down against the platform. As the platform is moved slightly towards the outside, the tyre will open a little and thus create enough space to insert the inner tube.

NB: The valve hole may be asymmetrical to the center of the rim. In this case position and insert the inner tube as shown in Fig .T.

Insert the valve through the hole and fix it with its locking ring.

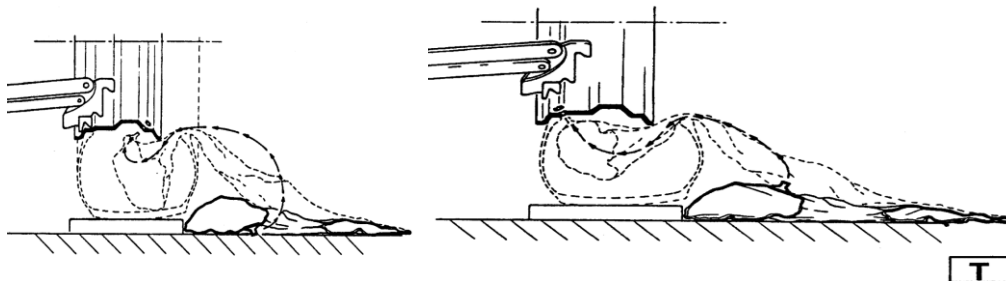

- 15) Place the inner tube in the center well of the rim (NB: to facilitate this, turn the spindle clockwise).
- 16) Turn the spindle until the valve is at the bottom (6 o'clock).
- 17) Inflate the inner tube a little (until it has no folds) so as not to pinch it while mounting the second bead.
- 18) Attach an extension to the valve and then remove the locking ring.

NB: The purpose of this operation is to allow the valve to be loose so that it is not ripped out during second bead mounting.



Take the mobile control unit to work position C.

- 19) Move the tool carrier arm (14, Fig. D) to its working position.
- 20) Bring the tool forward until the red reference dot is lined up with the outside edge of the rim and about 5 mm from it.

-
- 21) Pull back on this lever which will guide the bead into centre well. Continue to turn the spindle until the tyre is completely mounted on the rim.
 - 22) Tip the tool carrier arm to its non-working position.
 - 23) Position the platform directly under the wheel and lower the spindle until the wheel rests on the platform.
 - 24) When the wheel is resting on the platform, check to make sure the valve is perfectly centered with its hole. If it is not, turn the spindle slightly to adjust the position. Fix the valve with its locking ring and remove the extension.
 - 25) Close the arms of the spindle completely. Support the wheel to prevent it falling off.
 - 26) Move the platform to release the wheel from the spindle.
 - 27) Remove the wheel.



DANGER!

This operation can be extremely dangerous.

Do it manually only if you are certain you can keep the wheel balanced.

***WHEELS WITH SPLIT RING BEAD BREAKING AND
DEMOUNTING***

WHEELS WITH 3-PIECE RINGS

- 1) Clamp the wheel on the spindle as described previously and check to make sure it has been deflated.
- 2) Take the mobile control unit to work position B.
- 3) Lower the tool carrier arm(**14, Fig.D**) to its work position until it is locked in position by its hook.
- 4) position the bead loosener disk level with the rim (**see Fig.W.**)

5) Turn the spindle and at the same time move the disk forward a bit at a time following the contour of the rim until the first bead is completely free (NB: lubricate while doing this).

CAUTION! If the tyre has an inner tube, work very carefully and be prepared to stop the disk immediately once the bead has been broken so as not to damage the valve and the inner tube.

6) Repeat this procedure but this time bring the disk against the split-ring (see **Fig.Z**) until the lock ring is freed. Remove this with the special lever TL (19 **Fig.Z**) or with the help of the disk.

7) Remove the split-ring.

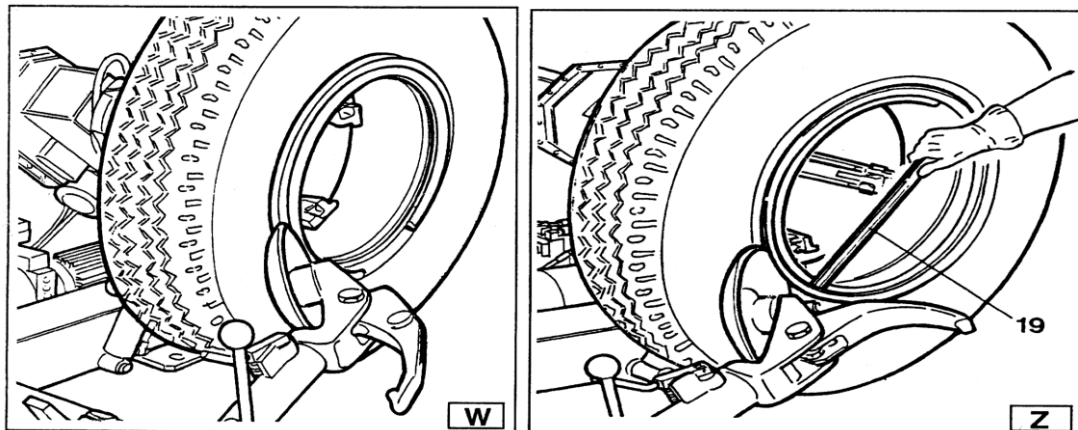

8) Move the tool carrier arm (14 **Fig.D**) back from the edge of the rim. Release the hook and tip the arm to its non-working position.

Move the tool carrier arm to the inside plane of the wheel.

9) Press lever (19 **Fig.D**) and turn the tool head 180° which will automatically lock in this position. Lower the arm to its working position.

10) Turn the spindle and at the same time bring the bead loosener disk up against the tyre following the contour of the split-ring until the second bead has been broken (NB: Lubricate during this process). Continue to move the disk forward until about half the tyre has demounted from the rim (see **Fig.K**).

11) Move the tool carrier arm to its non-working position.

-
- 12) Move the platform(4 Fig.A) directly under the wheel .
 - 13) Lower the spindle until the wheel is resting on the platform.



Take the mobile control unit to work position B.

- 14) Move the platform towards the outside until the tyre completely off the rim. Watch out for the valve!

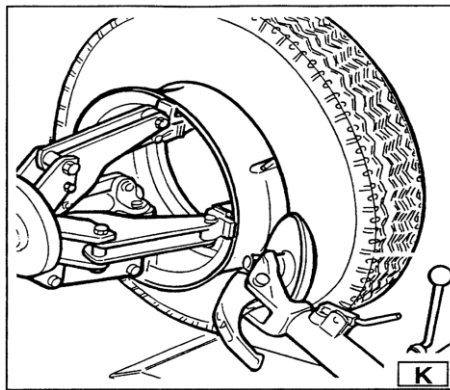

WHEELS WITH 5-SEGMENT SPLIT RINGS

- 1) Clamp the wheel on the spindle as described previously make sure it is deflated.

Take the mobile control unit to work position C.



- 2) Lower the tool carrier arm (14 Fig .D) to its work position until its hook has clicked into position on the bar.
- 3) Use the joystick to position the wheel so that the bead breaker disk touches up against outside edge of the centre well rim.
- 4) Turn the spindle and at the same time move the bead breaker disk forward until the split-ring is detached. Watch out for the o-ring.
- 5) Repeat this operation but this time move the disk against the split-ring(see Fig.Z) until the locking ring is released. This ring can be removed with the special TL lever (19, Fig.Z) or with the help of the bead disk.
- 6) Remove the o-ring.

- 7) Move the tool carrier arm (14, Fig.D) back from the edge of the rim. Release the hook and tip the arm to its non-working position.
- 8) Press lever (19, Fig.D) and turn the tool head 180° which will automatically lock in this position. Lower the arm to its working position.



Take the mobile control unit to work position D.

- 9) Turn the spindle and at the same time bring the bead loosener disk up against the tyre between the rim and bead. Move the disk into the tyre only when the bead has started to detach from the rim and move the bead to the outside edge of the rim. (NB: Lubricate during this process).
- 10) Tip the tool carrier arm to its non-work position.



Take the mobile control unit to work position B.

- 11) Move the platform (4, Fig.A) directly under the wheel.
- 12) Lower the spindle until the wheel is resting on the platform.
- 13) Move the platform towards the outside until the tyre together with the split ring comes completely off the rim.
- 14) Remove the rim from the spindle.
- 15) Position the tyre on the platform with the split ring turned towards the spindle.
- 16) Clamp the split ring on the spindle as explained in the section of CLAMPING THE WHEEL .



DANGER!

The tyre is not attached to the split ring completely safely. Any strain on it during position or clamping operations could cause it



Take the mobile control unit to work position D.

- 17) Lift the wheel.
- 18) Move the tool carrier arm back to its work position.
- 19) Position the spindle so that the bead breaker disk is lined up with the bead.
- 20) Turn the spindle and move the disk forward until the tyre comes completely off the split ring.



DANGER!

When the beads come off the rim, the wheel will fall. Check to make sure there are no by-standers in the work area.

MOUNTING

WHEELS WITH 3-PIECE SPLIT-RINGS

- 1) Move the tool carrier arm to its non-working position. If the rim has been removed from the spindle, put it back on the spindle as described in the section on “CLAMPING THE WHEEL”

If the tyre is tubed, position the rim with the valve slot at the bottom(6 o'clock).

- 2) Lubricate both beads and the rim with tyre manufacturer recommended lubricant.
- 3)



Take the mobile control unit to work position B.

- 4) Move the platform to be able to place the tyre on it.

NB:If the tyre is tubed, position the rim with the valve slot at the bottom(6 o'clock)

- 5) Lower or raise the spindle to centre the rim and the tyre.
- 6) Move the platform forward until the rim is inserted into the tyre.

CAUTION! If the tyre is tubed push the valve inside so as not to damage it. Move forward with the platform until rim is completely in the tyre.

- 7) Bring the tool carrier arm to the outside plane and lower it to its work position with the disk towards the wheel.

NB: If the tyre is not inserted sufficiently on the rim, move the spindle until the tyre bead is by the disk. Bring the disk forward (with the spindle turning) until it is completely inserted.

- 8) Put the split-ring on the rim and then install the locking ring with the help of the disk as shown in Fig .Y.
- 9) Move the tool carrier arm to its non-working position and, at the same time, close the spindle arms. Support the wheel so that it does not fall off.



DANGER!

This operation can be extremely dangerous.

Do it manually only if you are certain you can keep the wheel balanced.

- 9) Move the platform to free the wheel from the spindle.

- 10) Remove the wheel.

WHEELS WITH 5-SEGMENT SPLIT-RINGS

- 1) Move the tool carrier arm to its non-working position. If the rim has been removed from the spindle, put it back on the spindle as described in the section on "CLAMPING THE WHEEL".
- 2) Lubricate both beads and the rim with tyre manufacturer recommended lubricant.



Take the mobile control unit to work position B.

- 3) Move the platform to be able to place the tyre on it.
- 4) Lower or raise the spindle to centre the rim and the tyre.

5) Move the platform forward until the rim is inserted into the tyre.

6) Put the split-ring on the rim and (with the lock ring already mounted).

NB: If the rim and the split-ring have slits for fixing devices, make sure they are lined up with each other.



Take the mobile control unit to work position C.

7) Move the tool carrier arm to the outside in its work position with the bead breaker disk turned towards the wheel.

NB: If the split-ring is not inserted sufficiently on the rim, move the spindle until the split-ring is by the disk. Bring the disk forward (with the spindle turning) until you “discover” the O-ring seating.

8) Lubricate the O-ring and its seating.



Take the mobile control unit to work position C.

9) Position the locking ring on the rim with the help of the disk as shown in Fig .Y.

Move the tool carrier arm to its non-working position and close the spindle arms completely. Support the wheel so that it does not fall off the spindle.

DANGER!



This operation can be extremely dangerous.

Do it manually only if you are certain you can keep the wheel balanced.

10) Move the platform to free the wheel from the spindle.

11) Remove the wheel.



DANGER!

Do not inflate the tyre with the wheel mounted on the spindle.

13 ORDINARY MAINTENANCE



WARNING!

Each maintenance operation must be effected only after the disconnection of the plug from electric network.

To ensure that this tyre changer works perfectly over the years, carry out the routine maintenance schedule described below:

1) **Lubricate** the following parts from time to time, after a thorough cleaning with naphtha:

- the various swivels on the spindle
- the tool bracket slide runner
- the carriage guide plate.

2) **Grease** the spindle bracket lift cylinder from time to time and also its swivel. Add the grease through the grease nipples (see Fig.J) using ordinary lubricating grease.

NB:To reach the grease nipple on the bracket, remove the plastic cap by removing the two self-tapping screws as shown in Fig .J.

3) From time to time **check** the oil level in the hydraulic power pack. Use the dipstick under the reservoir cap.

If necessary top up with Esso Nuto H46 or similar hydraulic oil (eg, Agip Oso 46, shell tellus oil 46, Mobil DTE 25, Castrol Hyspin AWS 46, Chevron RPM EP Hydraulic oil 46, BP Energol HLP).

4) From time to time **check** the oil level in the gear unit which, when the tool carrier bracket is completely lowered at end travel, should not show the sight glass on the gear casing as completely empty. If necessary top up with Esso Spartan EP 320 or similar oil(eg, Agip F1 REP 237, BP GRX P 320, Chevron Gear Compound 320, Mobil Gear 632, sell omala oil 320, Castrol Alpha SP 320).

NB: If the oil in the gear unit or the hydraulic power pack has to be changed, note that the gear unit casing and the power pack reservoir have specific drain plugs.

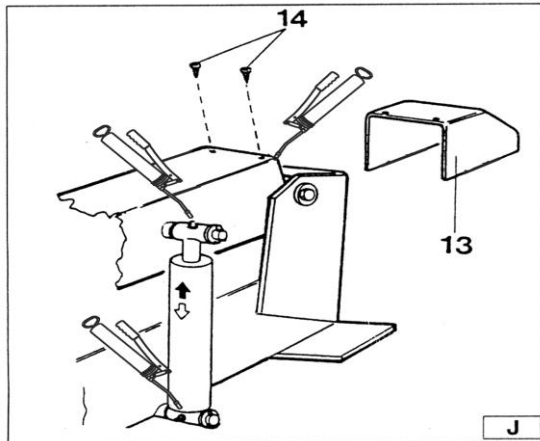

WARNING!

Each maintenance operation must be effected only after the disconnection of the plug

14 TROUBLE SHOOTING

After having switched the general button on the electric pack, the general warning light does not light on and no control can function.

1) The feeding plug is not connected.

1) Insert plug in the socket.

After having switched the general button on the general warning light also switches on but the motor on the hydraulic power pack does not function.

1)The emergency switch for motor protection is working.

1)Call for technical aid to see what is the problem and restore the machine.

**WARNING:**

If , inspite of the above mentioned indications the tyre changer

15 MOVING THE MACHINE

The tyre changer has got a fork(1, Fig.A) which has been position there on purpose for moving the machine.

Follow these instructions:

- 1) Low the turntable holding arm (2, Fig .A) completely down.
- 2) Close completely the jaws of the chuck(3, Fig.A).
- 3) Bring the sliding table(4, Fig.A) at the end of its travel, near the arm.
- 4) Insert into the lifting fork a hoisting belt (at least 60 mm wide and of a length sufficient to bring the hook of the belt above the tyre changer).
- 5) With the special belt ring bring the 2 ends of the belt together and lift with a sufficiently strong lifting truck.

16 STORING

If the machine as to be stored for a long time 3-4 months you have to :

- 1) Close the jaws of the chuck; low the chuck holding arm down; low the tool holding arm down, in working position.
- 2) Disconnect the machine form all power sources.
- 3) Grease all the parts that could be damaged if they dry out:
 - the chuck
 - the slot of the tool holding arm
 - the slides of the carriage
 - the tool

Empty oil/hydraulic fluid reservoirs and wrap the machine in a sheet of protective platic to prevent dust from reaching the internal working parts.

If the machine as to working again after a long storing period, it is necessary to :

-put the oil into the reservoirs again.

-with a turn screw press the pin on the middle of the electro-valves of the hidraulic power pack(see Fig .X) in order to manually unlock the electro-Valves which could be locked after a long period of inactivity.

-restore the electric connection.

17 SCRAPPING A MACHINE

When you machine's working life is over and it can no longer be used, it must be made inoperative by removing any connection to power sources.

These units are considered as special waste material, it should be broken down into uniform parts and disposed of in compliance with current laws and regulations.

If the packing are not polluting or non-biodegradable, deliver them to appropriate handline station.