

General Index

DESCRIPTION OF THE MACHINE	1.0
Intended use.....	1.1
Precautions	1.2
General safety rule.....	1.3
technical terms.....	1.4
Technical Data.....	1.5
Precautions when the equipment is put into service.....	1.6
Equipment presetting and special requirements.....	1.7
Problems due to misoperation and means of settlement.....	1.8
Safety requirements.....	1.9
Transportation.....	2.0
Unpacking.....	2.1
Positioning and assembly.....	3.0
Electric installation.....	3.1
Air source installation	3.2
Operating Tests	4.0
Operation	5.0
Inflating	5.1
Maintenance	6.0
Storage.....	7.0
Moving.....	8.0
Scrapping.....	9.0
Electric diagrams.....	10.0
Trouble shooting.....	11.0

1. 0 DESCRIPTION OF THE MACHINE

Thank you for purchasing a product from the line of semi-automatic tyre changers. The machine has been manufactured in accordance with the very best ISO9002 quality principles. Follow the simple instructions provided in this manual to ensure the correct operation and long life of the machine. Read the entire manual thoroughly and make sure you understand it.

1. 1 Intended use

The semi-automatic tyre changer has been designed and manufactured exclusively for removing and mounting tyres from/onto rims and inflating the tyres. With the unique help device, it could handle tyres with hard and stiff tire wall.

Max. Tire Dia.1000mm

Max. Tire Width. 12"

. • In particular the manufacturer cannot be held responsible for any damage caused through the use of this tyre changer for purposes other than those specified in this manual, and therefore inappropriate, incorrect and unreasonable.

1. 2 Precautions

The non-operator is not allowed to near the warning labels. These labels should not be removed. Any tampering or modification to the equipment carried out without the manufacturer's prior authorization will free him from all responsibility for damage caused directly or indirectly by the above actions.

1.3 General safety rule

When choosing the place of installation be sure that it complies with current safety at work regulations. •The tyre changer must be connected to the mains electric power supply and the compressed air system. It is therefore advisable to install the machine near these power sources. •The place of installation must also provide at least the space shown in figure1 so as to allow all parts of the machine to operate correctly and without any restriction. •If the machine is installed outside it must be protected by a lean-to. The tyre changer with electric motor cannot be used in explosive atmospheres.

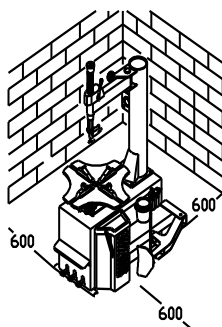

(fig.1)

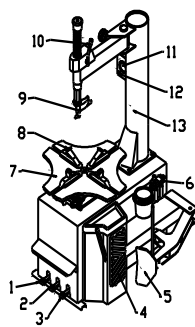

(fig.2)

1.4 technical terms

Before the installation and operation, you have to understand the technical terms of the machine.(fig.2)

1 Reverser control pedal 2 Clamp control pedal 3 Bead breaker control pedal 4 Wheel support
5 Bead breaker 6 Atomized lubricator 7 Turntable 8 Clamps 9 Mounting tool

10 Locking lever 11 Pressure gauge 12 deflating button 13 Vertical arm

1.5 Technical Data

Net weight :255kg

Working pressure: 8-12bar

Motor power: : 1.1kw/0.75kw

Power supply : 220V/50HZ

 110V/60HZ

 380V/50HZ

Rotation rate : 7R/MIN

Max. Tire Dia.: 1100mm

Max. Tire Width : 15”

External locking rim diameter : 13”-24”

Internal locking rim diameter : 15”-26”

Working temperature : 0-45°C

Noise level in working condition : <70dB.

1.6 Precautions when the equipment is put into service

The operation and the maintenance of the equipment must obey the laws and rules stipulated for the dangerous free.

Be sure the machine is properly connected to the power supply and electrically grounded.

Be sure that the machine is fixed on the ground firmly.

Before the maintenance operation, the air supply and power supply should be cut off.

Keep hair, loose clothing, fingers, and all parts of body away from moving parts.

Do not wear jewelry, loose clothing, neckties, or gloves when operating the machine.

Wear proper clothing. Safety toe, non-slip footwear and protective hair covering to contain hair is recommended.

Keep work area clean and well lighted. Cluttered and/or dark areas invite accidents. Avoid dangerous environments. Do not use power tools or electrical equipment in damp or wet locations, or expose them to rain.

1.7 Equipment presetting and special requirements

Air pressure presetting: The machine could run normally when the air pressure is 8-10bar. The air pressure should not less than 8 bar.

Mounting tool presetting: The mounting tool is already calibrated according to a standard 13” rim. For a bigger or smaller rim, you have to loose bolts fixing on the mounting tool and at the bottom of the hexagonal bar. Adjust the mounting tool to a suitable position.

Oil mass presetting: The oil mass in the atomized lubricator is already well prepared before it leave the factory. If the fluid rate is too fast or too slow, adjust the needle valve by a screwdriver.

-Check that a drop of oil is injected into the reservoir every 5-6 times the pedal is pressed down.

Termly refill 30 # oil into the reservoir.

1.8 Problems due to misoperation and means of settlement

Make sure that the machine is well grounded to avoid electric leakage

To prevent industrial accidents, do not place your legs between the tire breaker and the wheel support. When the bead breaker pedal is operated the bead breaker arm moves quickly and powerfully. Anything within its range of action can be in danger of being crushed.

Bead breaking with the clamps in open position can be extremely dangerous for operator's hands.

ALWAYS keep hands and body back from inflating tyre

To prevent industrial accidents, keep hands and other parts of the body as far as possible from the tool arm when the table top is turning.

Do not place your hands on the wheel: when moving the arm to its working position your hand could be crushed between the rim and the mounting head.

During bead breaking operations NEVER touch the side of the tyre.

The operator should concentrate on his/her work.

2.0 Transportation

The tyre changer must be transported in its original packaging and kept in the position shown on the package itself.

- The packaged machine may be moved by means of a fork lift truck of suitable capacity. Insert the forks at the points shown in figure 3.

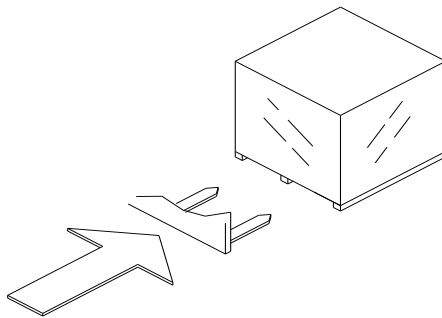

(fig.3)

2.1 Unpacking

After removing the package be sure that the equipment is complete and intact, checking that no visible damage is present. In case of doubt DO NOT USE THE MACHINE and apply to professionally skilled personnel (to your own seller).

Do not leave packaging parts (plastic bags, foamed polystyrene, nails, screws, wooden parts etc) within the reach of children as they may be dangerous.

Throw the above mentioned material in the proper waste collection centres if polluting or not decomposable into organic substances.

Note: When unpacking the machine, wear a proper glove to prevent the scratch to your hand.

3.0 Positioning and assembly

Set the tyre-changer on the floor. Fix the machine on the ground using expanded bolt. Set the vertical arm on the cabinet(do not damage the screw thread beneath the seat of the vertical arm),tighten the vertical arm with screw(fig.4). Remove the side panel on the side of the body of the machine, with the rubber seal pad on the slipknot of the flow dividing valve, connect the slipknot to the screw thread.

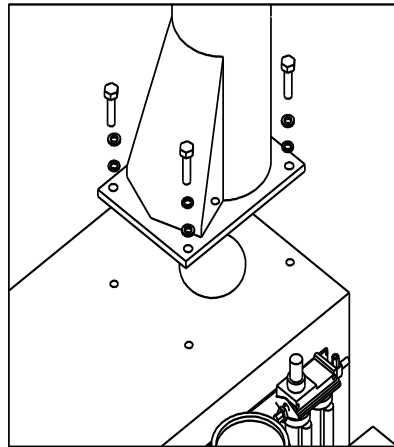

(fig.4)

3.1 Electric installation .

Even small jobs done on the electrical system must be carried out by professionally qualified personnel.

Connect the machine to the electric network, which must be provided with line fuses, a good earth plate in compliance with regulations in force and it must be connected to an automatic circuit breaker (differential) set at 30 mA

Note: Should the tyre-changer be lacking in electric plug, so the user must set one, which is at least 16 A and which conforms to the voltage of the machine, in compliance with the regulations in force.

3.1.1 Test the rotation direction of the motor

This test is only for the tire changer with 3 phases.

When pedal 1 is pressed down, the turntable should turn in a clockwise direction

If the turntable turns in the opposite direction to that shown, reverse two of the wires in the three-phase plug. The manufacturer will not take that responsibility for any damage due to the failure to carry out the test.

3.2 Air source installation

This kind of job must be done by by professionally qualified personnel.

The work pressure of the machine should be 8-10 bar to ensure the normal run. If the pressure is less than 8bar(or 117psi), the machine could not handle some kinds of tires. The air compressor should be equipped with an oil mist separator to decrease the water content at the air entrance to the tire changer. The water in the air compressor should be drained away termly.

Connect the joint of the oil mist separator on the right side of the machine to the air compressor system. The air pressure showed in the air gauge of the oil mist separator should meet the required air pressure, else check the hose and the air compressor.

4.0 Operating Tests

Turn the handle(10) to lock the horizontal arm.

•When pedal (1) is pressed down, the turntable (7) should turn in a clockwise direction.

When pedal (1) is pulled up, the turntable (7) should turn in an anticlockwise direction .

Pressing the pedal (2) opens the four clamps (7) ; when the pedal is pressed again they close.

Pressing the pedal (3) activates the bead breaker; when the pedal is released the bead breaker returns to its original position.

Pressing lightly the quick inflating pedal on the side of the machine body, the inflating gun deflate.

Pressing the quick inflating pedal on the side of the machine body again, the inflating gun and the eyelet near the sliding block deflate at the same time.

5.0Operation

The operation of the tyre changer is divided into three parts:

a) BREAKING THE BEAD b) REMOVING THE TYRE c) MOUNTING THE TYRE

Note: The tire changer must be operated by a professional personnel.

Before carrying out any operation, deflate the tyre and take off all the wheel balancing weights.(fig.5)

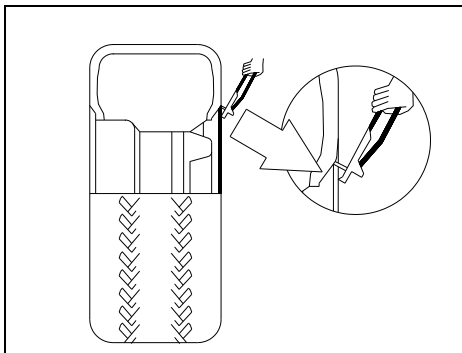

(fig.5)

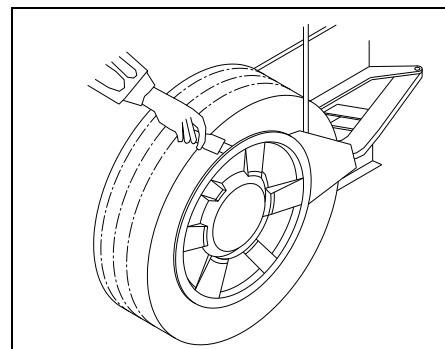

(fig.6)

Remove the tire:

1. Position the wheel against the rubber stops on the right side of the tyre changer , Position the bead breaker blade against the tyre bead at a distance of about 1 cm from the rim . •Press down the pedal to activate the bead breaker and release it when the blade has reached the end of its travel or in

any case when the bead is broken.(fig.6)

•Spread the supplied grease (or grease of a similar type) onto the tyre bead.

2. Rotate the tyre slightly and repeat the operation around the entire circumference of the rim and from both sides until the bead is completely detached from the rim.
3. Move the operating arm until the mounting tool rests on the rim upper edge. Then lock everything by setting the locking button in lock position .
In this way, the arm gets locked both in a vertical and in a horizontal direction, while the mounting tool is moved automatically of about 3 mm. from rim.

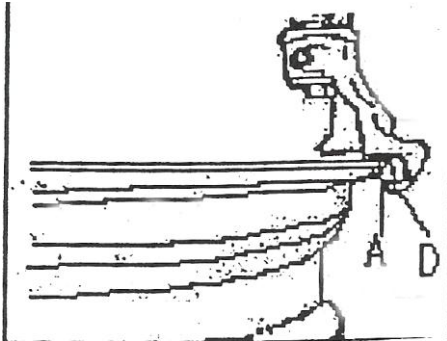

(fig7)



4. With the lever inserted between the bead and the front section of the mounting head, move the tyre bead over the mounting head(fig7 and fig8). let the turntable rotate in a clockwise direction by pressing pedal down until the tyre is completely separated from the wheel rim (Fig. 8). In order to avoid damaging the inner tube, if there is one, it is advisable to carry out this operation with the valve about 10 cm .
right of the mounting head.

- 5.Remove the inner tire, if there is one. Repeat the operation for the other bead.(fig8)

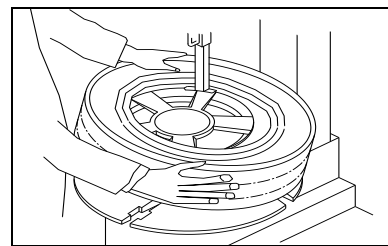
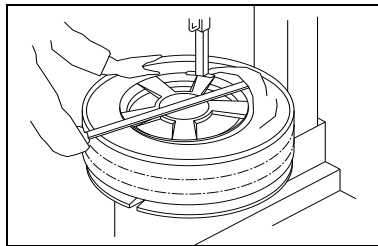

(fig.8)

Mounting the tire

Before this operation, make sure that the tire and the rim is matching.

1. Lock the rim on the turntable.
2. Move the tyre so that the bead passes below the front section of the mounting head and is brought up against the edge of the rear section of the mounting head itself.(fig7,9)
3. Lubricate the tyre beads with the special grease in order to avoid damaging them and to facilitate the mounting operations. Keeping the tyre bead pressed down into the wheel rim channel with your hands, press down on the pedal to rotate the turntable clockwise. Continue until you have covered the entire circumference of the wheel rim..
4. Insert the inner tube (if there is one) and repeat the same operations to mount the upper side of the tyre

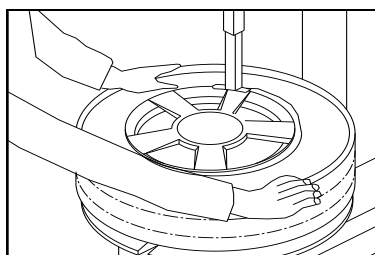

(fig.9)

5.1 Inflating (fig.10)

In the standard version our tyre changers are supplied with an airline gauge. To inflate a tyre proceed as follows:

1. •Connect the airline gauge fitting to the tyre valve.
2. Inflate the tire with inner tube or some easy-inflating vacuum tire.

Press the inflating pedal to 1 shift, •Continue to inflate the tyre and constantly checking the pressure between air jets until the required pressure has been reached. If exceed the required pressure, exhaust it by pressing deflating button.

3. Inflate the hard-inflating tire

•If the bead of tyre is not well seated, due to a strong bead, inflate the tire with the inflating gun, a strong jet of air will be released through the edge of the tire. Lift tyre manually until the upper bead seals against the rim, then press pedal to the shift 2 position, NEVER exceed the max. inflating pressure given by the tyre manufacturer

•The greatest attention is called for when inflating the tyres. Keep strictly to the following instructions since the tyre changer is NOT designed and built to protect the user (or anyone else in the vicinity of the machine) if the tyre bursts accidentally. Keep your hands and body as far away as possible from the tyre.

• Check the state of wear of the tyre and that it has no defects before beginning the inflation stage. Never exceed the pressure 3.5 bar.

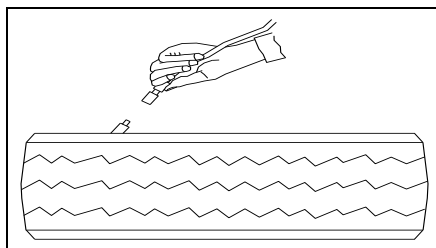

(fig.10)

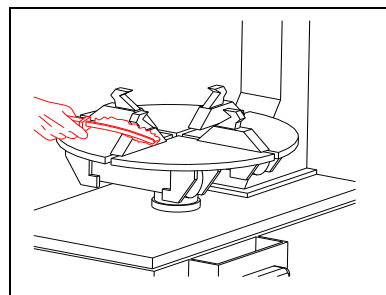

(fig.11)

6.0 Maintenance

Unauthorized personnel may not carry out maintenance work.

•Regular maintenance as described in the instructions is essential for correct operation and long lifetime of the tyre changer.

Before carrying out any maintenance work, disconnect the electric and pneumatic supplies.

-Check the oil level in the lubricator tank. If necessary, fill up by unscrewing the reservoir. Only use air pressure mineral oil SEA30 for that.

Clean the reservoir and oil mist separator termly , so as to prevent the formation of dirt.

Clean all the moving parts clamping the rim.(fig.11)

Check and tighten all the bolts of connecting fitting termly.

Keep the hexagonal vertical arm dry and clean (use diesel oil) (fig.12)

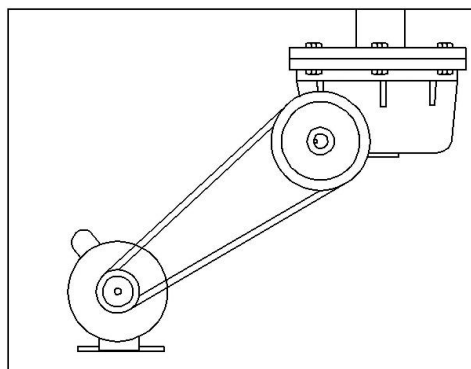
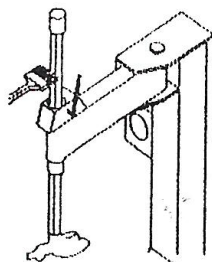

(fig.13)

Check the tensile force of the drive belt, when adjust that, Tighten the drive belt by means of the special adjusting screw on the motor support . (Fig.13)

Keep the machine and working area clean to avoid the entrance of dust.

Lubricate the junction plane between two contacted part termly using lithium based grease oil.

Clean the silencer for opening/closing clamps termly. Unscrew the silencer put on the pedal system, Clean it by a jet of compressed air or water.

Clean the turntable once the tire is mounted or demounted to avoid the scratch to that.

If the vertical arm doesn't lock tightly, proceed as follows:

Disconnect the air power supplies, remove the protection hood of the vertical arm, adjust the locking nut on the adjustment leading screw or the screw at the front end of locking plate until the vertical arm is locked.

7.0 Storage

In the event of storage for long periods of time, be sure to:

- Disconnect all sources of power and grease the clamp sliding guides on the turntable to prevent them from oxidising.

8.0 Moving

To move the tyre changer you will need a fork-lift truck.

- Disconnect the pneumatic and electric power supplies.
- Apply leverage to one side of the base so as to raise it slightly from the floor, insert the forks of the truck under the base and slide the tyre changer onto them.
- Set the tyre changer down in its new position.

Note: The place chosen for repositioning the tyre changer must comply with safety at work standards.

9.0 SCRAPPING

If you decide to scrap the machine, be sure to make it inoperative by disconnecting it from all sources of power.

- Remove all NON-ferrous materials and dispose of them as prescribed by national law.
- Collect the oil and dispose of it at an authorized point as prescribed by national law.
- Scrap the rest as ferrous material.

10.0 Electric diagrams

This work concerning the electric part must be carried out by the qualified personnel.

If the rated power voltage is 220V or 110V, make sure the stability of power to avoid the damage to the capacitor.

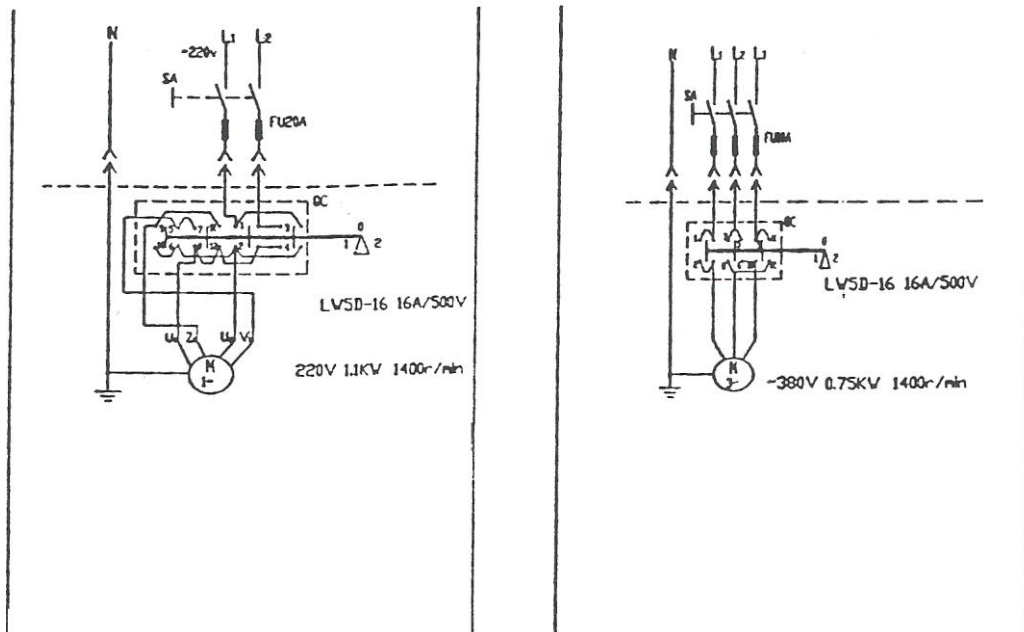

11.0 Trouble shooting

Turntable rotates only in one direction

Reason :Reverser broken. Solution: Replace reverser

Turntable does not rotate

Reason : Belt broken, Reverser broken, Problem with motor

Solution: Replace the belt, Reverser, Check for loose wire in the motor, plug or socket , Replace motor

Turntable does not lock the wheel rim correctly -

Reason: Clamps worn, Turntable cylinder(s) defective

Solution: Replace clamps, Replace cylinder gaskets

Pedals lock out of working position

Reason: Return spring broken

Solution: Replace spring