

# **ROCKER ARM TIRE CHANGER**

( LC810 )

## **INSTRUCTION MANUAL**

Honest to customers

Quality & Renovation

Dear customers,

Very pleased that you will purchase and use the tire changer produced by our company.

We are the company with reputation of quality. We sincerely wish to produce quality goods under the ISO9001 Quality system and get the EU CE certificate to help you promote your business.

Please read carefully this user manual before installation and use of the machine and keep the manual well for check at any time.



Model: \_\_\_\_\_

Rated Voltage:            Phase            voltage            Hz

Factory Code: \_\_\_\_\_

Technical Standard Code    Q/YGM001--2006

This product has passed the examination

### **WARNING**

This instruction manual is the important part of the product. Please read it carefully and keep it properly in order to use it when maintain and examine the machine.

This machine is only applied to mount, demount and inflate the tire in the specified scope and not for any other purpose.

The manufacturer will not be responsible for the damage or injury caused for the operation not properly and out of the range.

### **NOTE**

This machine should be operated by the special trained qualified personnel. When operating, the unauthorized personnel will be kept far away from the machine.

Please note the safety label stuck on the machine.

Operators should wear safety protective facilities such as working suit, protective glasses, and earplug and safety shoes. Keep your hands and body from the movable parts as possible as you can. Necklace, bracelet and loosen clothing may cause dangerous to the operators.

Tire changer should be installed and fixed on the flat and solid floor. The more than 0.5m of distance from the rear and lateral side of the machine to the wall can guarantee the perfect air flow and enough operation space.

Do not place the machine in the site of high temperature, high humidity, and dust and with flammable and corrosion gas.

Without the permission from the manufacturer, any change on the machine parts will cause injury/damage to the machine/operator.

Pay attention that the tire changer should be operated under the specified voltage and air pressure.

If you want to move the tire changer, you should under the guidance of the professional service personnel.

**SAFTTY LABEL INSTRUCTION**



Keep your hands far from tire when operation.

Carefully read operation manual before operation

When operation, wear the protective facilities



electrical shock !



Do not reach any part of your body under the demount tool.



When breaking bead, the bead breaking



Note: when press the tire, the opened clamp cylinder may injure the hand of the operator.

Remember; do not touch the sidewall of the tire. Blade will quickly move leftwards.



When clamping the rim, do not reach your hand or other parts of the body in between the clamp& the rim.



When rapid inflation, ensure the wheel clamped.

When operation, do not wear long hair, loosen clothing and

When operation, do not reach y our hand under the falling objects, Jewelries.

# SAFETY LABEL POSITION DIAGRAM

Pay attention to keep the safety labels complete. When it is not clear of missing, you should change the new label.

You should let the operators see the safety labels clearly and understand the meaning of the label.

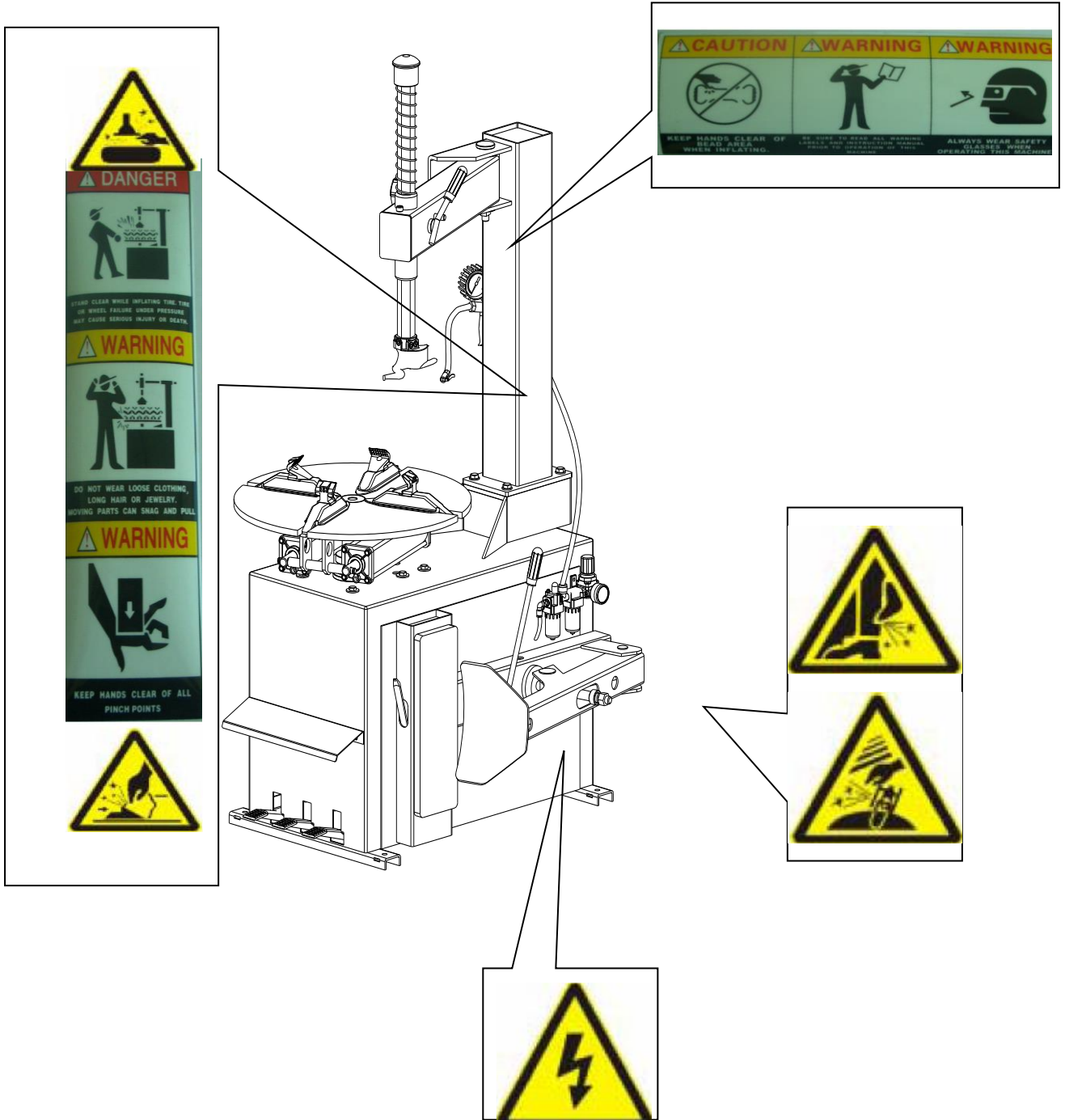

# CONTENT

## CHAPTER I BRIEF INTRODUCTION

1.1 BRIEF INTRODUCTION

1.2 EQUIPMENT OVERALL DIMENSION (EXCLUDING THE ASSISTANT)

1.3 TECHNICAL PARAMETER

1.4 APPLICATION SCOPE

1.5 ENVIRONMENT REQUIREMENT

## CHAPTER II CONFIGURATION AND OPERATION

## CHAPTER III INSTALLATION AND CALIBRATION

3.1 OPEN PACKAGE CARTON

3.2 INSTALLATION OF THE COLUMN

3.3 AIR SOURCE INSTALLATION

## CHAPTER IV DEMOUNT AND MOUNT TIRE

4.1 DEMOUNT TIRE

4.2 MOUNT TIRE

4.3 INFLATION

4.4 RAPID INFLATION

## CHAPTER V MAINTENANCE AND REPAIR

## CHAPTER VI INSTALLATION & OPERATION OF THE ASSISTANT ARM

6.1 LEFT ASSISTANT INSTALLATION

6.2 RIGHT ASSISTANT INSTALLATION

## CHAPTER VII TRANSPORTATION

## CHAPTER VIII ELECTRICAL AND PNEUMATIC DRAWING

## CHAPTER IX GENERAL TROUBLESHOOTING AND SOLUTION

ATTACHED PAGE: EQUIPMENT OIL EXPENSES SAFETY SHEET

## CHAPTER I BRIEF INTRODUCTION

### 1.1 BRIEF INTRODUCTION

This series of equipment is the tire changer with fixed column and rocker arm tire changer. It is suitable to mount, demount and inflate all types of motorcycle tire with tube & tubeless. The operation is easy, convenient, safety and reliable. It is the necessary equipment for the auto service shop and tire shop.

This series of machine can be divided into 3 models. They are LC890(S), LC850, and LC112 (square column). The corresponding models with the quick inflation function are: GT890, GT850. Among them LC890 and GT890 can be equipped with the assistant to adapt to demount and mount the low profile and stiff tires.

### 1.2 EQUIPMENT OVERALL DIMENSION (EXCLUDING THE ASSISTANT)

model	height (mm)	length (mm)	width (mm)	Net weight kg
LC(GT) 890	2040	1135	870	223/233
LC(GT) 850	1820	985	780	200/210
LC112	1815	965	795	190

### 1.3 TECHNICAL PARAMETER

Operation pressure: 8-10bar

motor: 50Hz 380V 0.75Kw (standard)

50Hz 220V (or 60Hz 110V) 1.1Kw (optional)

turntable speed: 6rpm

noise: <70dB (A)

### 1.4 APPLICATION SCOPE

model	Max. wheel diameter	Max. wheel width	rim diameter (outer clamp)	rim diameter (inner clamp)
LC890 (GT)	1250mm(49")	400mm(16")	10"~20"	12"~23"
LC850 (GT)	960mm(37")	305mm(12")	10"~18"	12"~21"
LC112	960mm(37")	305mm(12")	10"~18"	12"~21"

### 1.5 ENVIRONMENT REQUIREMENT

ambient temperature 0°C ~ 45°C

relative humidity 30~95%

Sea level max.1000M

Without dust and flammable and explosive gas

The operation space around the machine will not smaller than the indicated in FIG1



If the machine is installed outdoors, you must have the protective sheds to protect the rain and sun. It is forbidden to use in the site with the flammable gas!

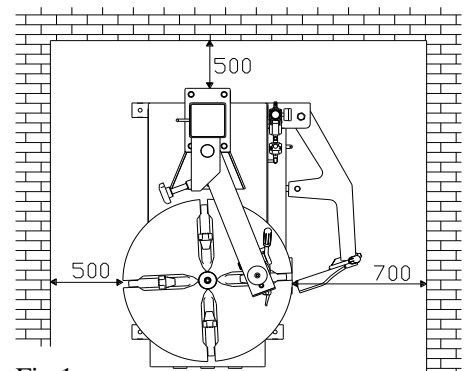

Fig 1

## CHAPTER II CONFIGERATION AND OPERATION

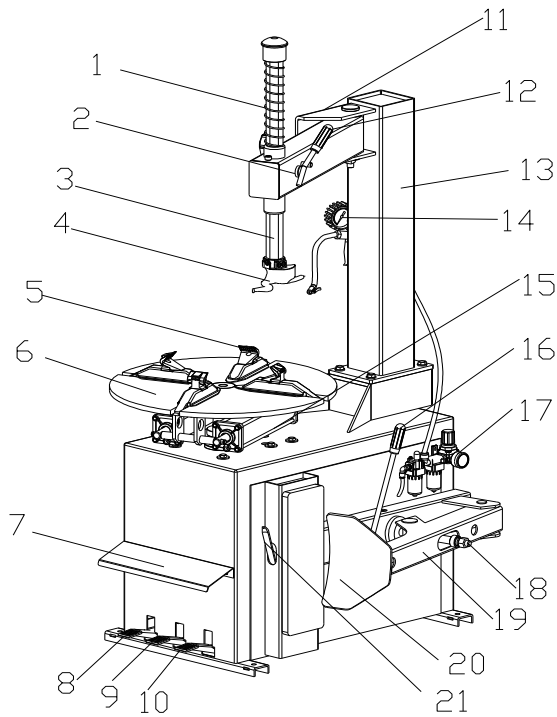

FIG 2

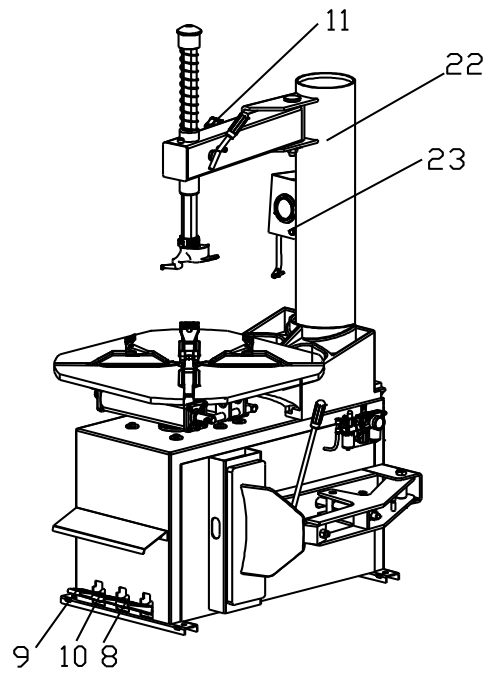

FIG 3

- |                         |                           |                        |                        |
|-------------------------|---------------------------|------------------------|------------------------|
| 1 vertical shaft spring | 2 rocker valve            | 3 hexagon shaft        | 4 demount head         |
| 5 claw                  | 6 turntable               | 7 operation label      | 8 turntable pedal      |
| 9 clamp pedal           | 10 tire press pedal       | 11 limit handle        | 12 lock handle         |
| 13 column               | 14 inflation gun          | 15 clamp cylinder      | 16 blade handle        |
| 17 air source fitting   | 18 bead breaking cylinder | 19 tire press arm      | 20 bead breaking blade |
| 21 crowbar              | 22 air tank               | 23 inflation gauge box |                        |



## CHAPTER III INSTALLATION AND CALIBRATION

Before installation and debug, carefully read this manual. The unauthorized change on the parts and spare parts of the machine will cause the damage on the machine.

Installation and debug personnel should have the specific electrical knowledge.

Operators must be trained and authorized.

Before installation, carefully read the equipment list. If any question, please contact with the dealers or our company.

To ensure the success of the installation and debug, please prepare the following common tools:

Two wrenches (10"), one socket wrenches, one set Allen Key, one pincer pliers, one screw driver, one hammer and one multi-purpose meter

### 3.1 UNPACK

3.1.1 According to the de-package instruction on the package box, to detach the box and remove the package material to check if the machine damage or not and if the spare parts completed.

3.1.2 Keep the package material far away from the working site and deal with it properly.

### 3.2 INSTALLATION

3.2.1 After un-package the package carton, take out accessory boxes (FIG 4-1), bead breaking arm (FIG 4-5) and column assembly (FIG 4-2). And position the body according to the FIG1.4. Remove the bolt (FIG 4-4), elastic washer and plate washer on the body.

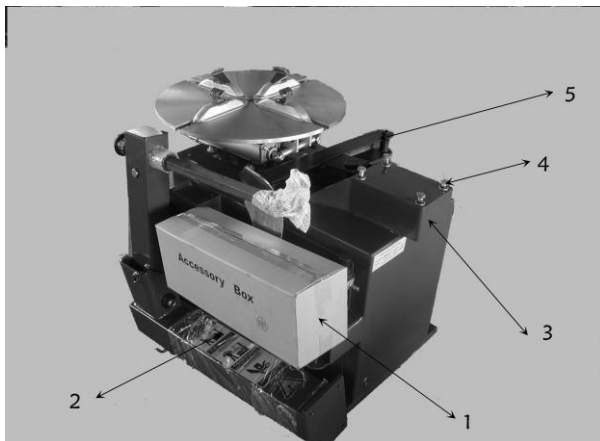

FIG 4

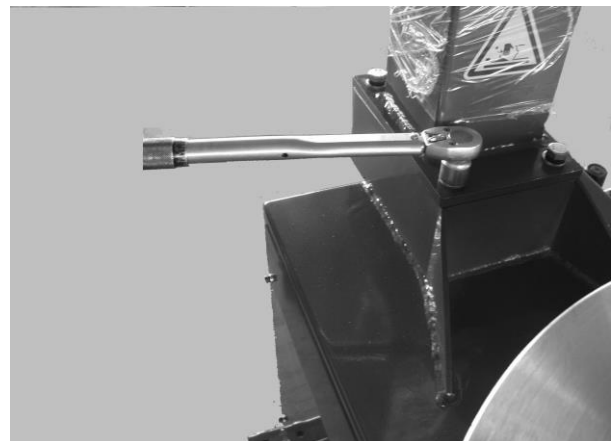

FIG 5

3.2.2 Place the column on the body. The direction of the warning label is forwards. Make the holes on the column base plate align to thread holes on the body. Once again assemble the removed the bolt (3.2.1), elastic washer and plate washer and plate washer removed in 3.2.1. The torque is 70 N·M (FIG5) Use torsion wrench to tight.

3.2.3 Use the wrench to remove the screw (FIG 6-3) hexangular shaft (FIG6-1) and take off the vertical shaft cap( FIG 6-2).



When remove the screw on the vertical shaft cap, you need use the lock handle to lock the hexangular shaft to avoid sliding off to damage the machine or injury personnel!

Install the vertical shaft spring (FIG7-1) on the vertical shaft. Mount the vertical shaft cap and mount the removed screw and assemble the hand wheel into the nut bushing of the rocker arm (FIG 7-2)。

3.2.4 Remove the lock nut at the front end of the bead breaking cylinder piston rod (FIG 8-1) and use the wrench to remove the nut on the bead breaking arm bolt (FIG8-4) Remove the bolt (FIG8-3) and hang the spring (FIG8-2)

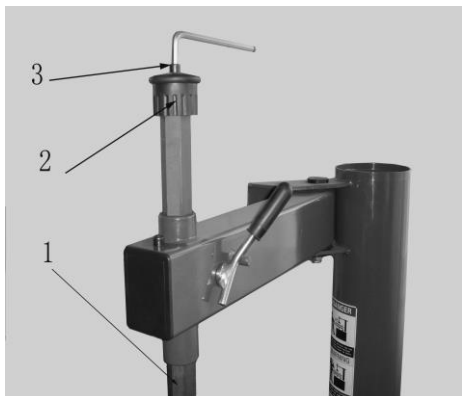

FIG 6

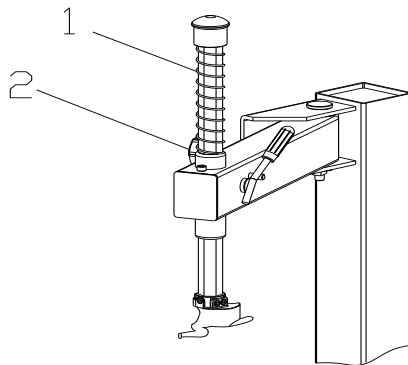

FIG 7

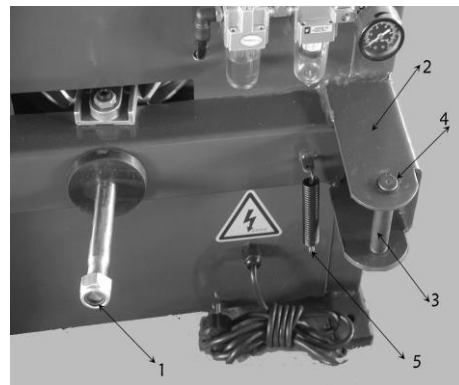

FIG 8

3.2.5 Position the bead breaking arm shaft bushing into the bead breaking support plate on the body (FIG 9-1) to align the hole and install the bead breaking bolt (FIG 9-2) and assemble the nut to lock (FIG 8-4) . Insert the piston rod(FIG10-2)through the hole of the bead breaking slide bushing(FIG10-1). The surface of the slide bushing should be outwards (FIG 10) . Assemble the removed nut (FIG 8-1) into the front end of the piston rod. The nut will be assembled. The distance from the edge of the bead breaking blade to the bead breaking rubber is 30~40mm (FIG11) . Hang the spring. (FIG9-3)。

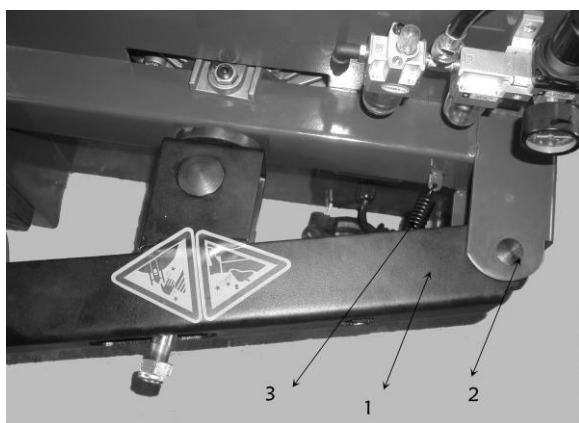

FIG 9

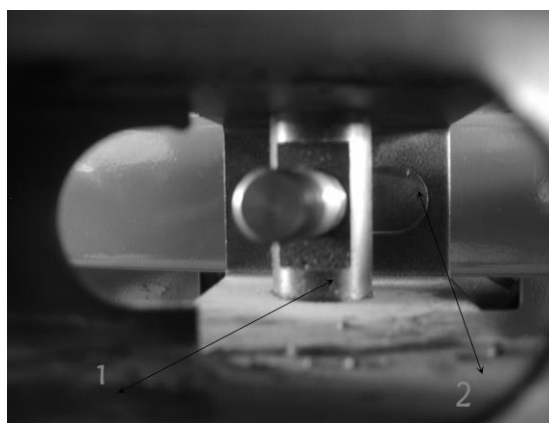

FIG 10

Note: If the machine is the one with the quick inflation, please open the side panel and insert 2 pieces of Ø12pu hose at the inlet of the quick deflation valve into the 2 Ø12nozzle and then install the side panel.

3.2.6 If being equipped with the tool box, you must fix firmly and the column completely installed.

### 3.3 AIR SOURCE FITTING INSTALLATION:

When the machine out of the factory, the air source fitting has been detached and placed in the accessory box and the fitting will be installed when it is in the site of the customers again.

3.3.1 Take out the air source fitting out from the accessory box and the screw and remove the oil and dust. Use the screw to fix it on the right side of the body (fig12).



FIG 11



FIG 12

3.3.2 Connect the air hose. Detach the adapter on the  $\varnothing 8$  PU hose on the side wall of the body and insert it into the elbow. See the fig13/14. And the adapter is to keep the hose from sliding into the body.



FIG 13

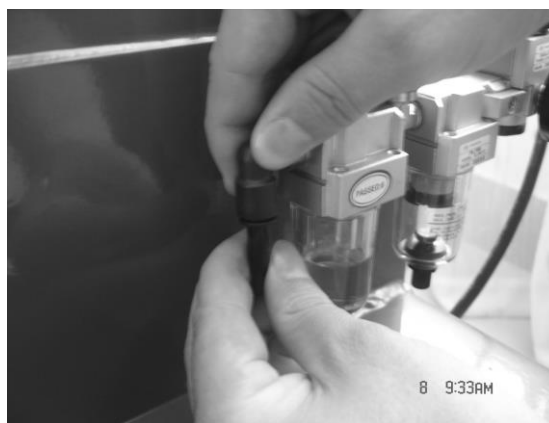

FIG 14

3.3.3 Connect the inflation gun or inflation gauge box: Inlay the adapter of the inflation gun or inflation gauge box into the groove (fig15) on the open nut on the air source fitting. Tighten the open nut and then connect the air source.

3.3.4 Air source has been adjusted before ex-factory. If it needs change, adjust again: **Pressure:** Lift up the pressure adjustable button( FIG16-1 ) and twist clockwise and the air pressure will increase. Meanwhile, if counterclockwise, the air pressure will decrease. **Oil Feed:** Use screw driver to twist the screw ( FIG16-2 ) . If clockwise, the oil dropping speed will slow. If counterclockwise, it will become fast.



FIG 15

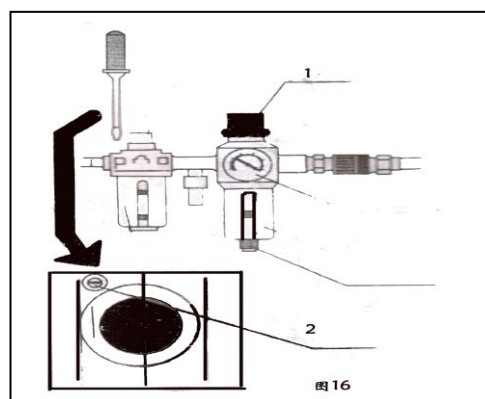

FIG 16

## CHAPTER IV DEMOUNT AND MOUNT TIRE

### 4.1 DEMOUNT TIRE

4.1.1 Deflate the air in the tire completely and pull out the core. Use the special tool to detach the weight on the rim (FIG17).

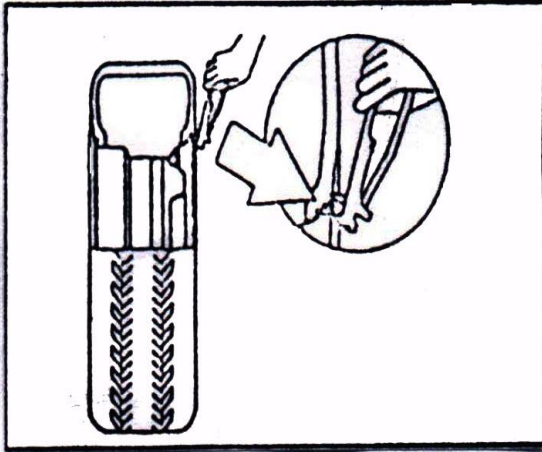

FIG 17

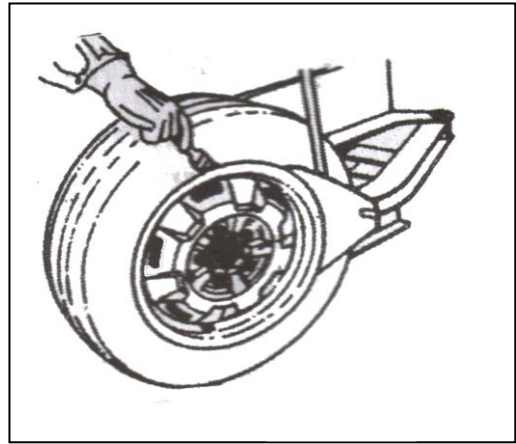

FIG 18

4.1.2 Place the tire between the bead breaking blade and tire pressing runner clog.(fig18) Then step down the tire press pedal to detach the rim from the tire(fig2-10 or 3-10). Repeat the same operation on the other parts of the tire to make the tire completely detached from the rim. Place the wheel with the tire detached from the rim on the turntable and step the clamp pedal (fig2-9; 3-9) to clamp the rim. You can select the outer clamp and inner clamp to clamp the wheel according to the different rim.



To detach the lip smoothly, you can use the brush to spread the lubricant or thick soap liquid between the lip and rim.

4.1.3 Position the hexangular shaft (FIG 2-3) to the working position to make the demount tool close to the rim of the wheel. And use the hand wheel (FIG 7-2) to push against the rocker arm and then use the lock handle (FIG 2-12) to lock. The demount tool will automatically move a little of gap (FIG19).



The angle of the demount tool has been calibrated according to the standard rim (13") . If handling the extra-big or extra-small rim, you can reposition.

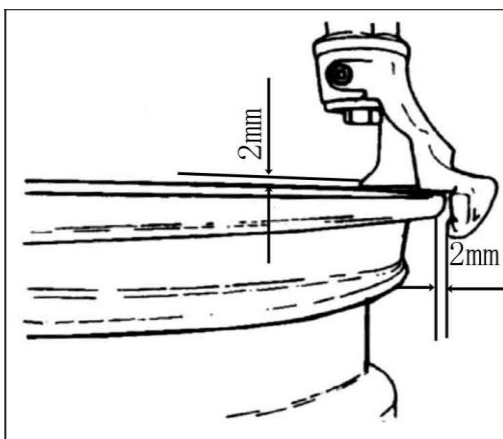

FIG 19

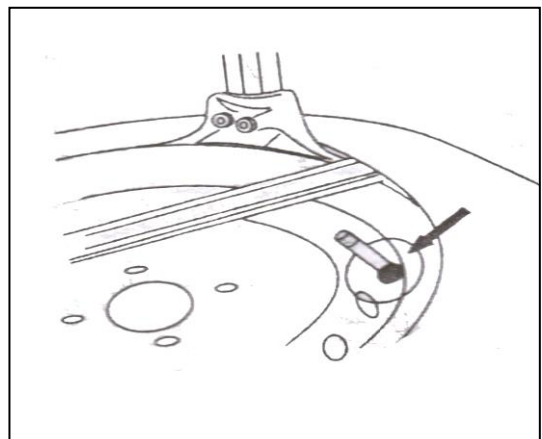

FIG 20

4.1.4 Use the crowbar to detach until the lip to the hump of the demount tool (FIG20). Step the turntable rotation pedal (FIG2-8) to rotate the turntable clockwise until the entire lip completely detached. If handling the tube tire, to avoid the damage on the tube, you should keep the nozzle of the tire 10cm from the right side of the demount tool when demounting.



If the demount of the tire is jammed, please stop the machine immediately and then lift up the pedal to let the turntable rotate counterclockwise to remove the resistance !

4.1.5 When handling the tube tire, Take out the tube and then move the lower lip upwards to the upper edge of the rim and then repeat the above steps to detach the other lip.



In the process of demounting tire, you should keep your hands and the other parts of your body from the movable parts. Necklace, bracelet and the loose clothing can injury personnel !

#### 4.2 MOUNT TIRE:



Before mount tire, check if the tire and rim are of the same dimension !

4.2.1 Clean the dirt and rust on the rim and lock it on the chuck. Lock the rim on the turntable.

4.2.2 Spread the lubrication liquid or soap liquid around the lip. Tilt the tire against the rim and keep the front end upwards. Press down the hexangular shaft to move the demount arm to contact with the rim and lock. The left lip above the tail of the demount tool and the right lip will be positioned under the front end of the demount tool (FIG 21), Clockwise rotate the turntable to guide the bottom lip into the tire detaching slot.

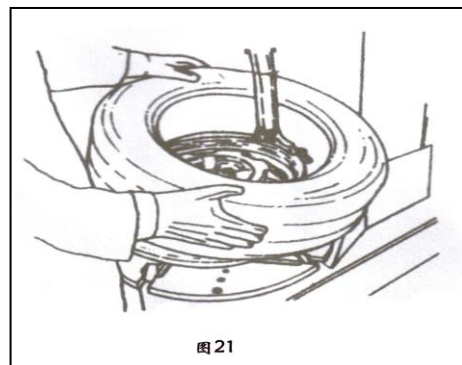

FIG 21

4.2.3 If there is tube, place it in the tire and plug the core. And assemble the lip according to the above mentioned step (FIG22). In the process of clamping the rim, do not reach your hands in between the rim and the claw to avoid the damage to the personnel.

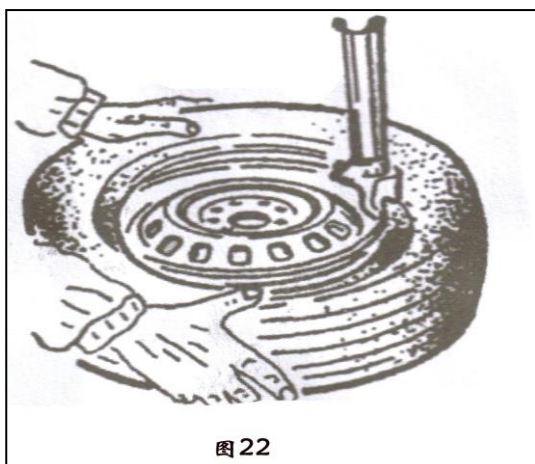

FIG 22



FIG 23

#### 4.3 INFLATION:

When inflating the tire, please be carefully and series obey the operation process. Check the air route to see if the air connection is OK. This machine is equipped with an inflation gauge for monitoring the inflation of the tire and the inflation pressure (FIG22) .

1. Loose the tire from the turntable.
2. Connect the inflation hose with the tire air core. See FIG23.
3. In the process of inflation, you should repeat switching the inflation gun to confirm the pressure indicated on the pressure gauge not exceed the scope specified by the manufacturer. The pressure decrease valve equipped in the machine make the pressure not to exceed 3.5bar. And the customer can get different inflation pressure by adjust the pressure decrease valve according to the requirement.
4. If the inflation pressures too high, you can press down the deflation press button on the inflation device to reach the required air pressure.

#### 4.4 Rapid Inflation (only for the machines with GT)

If the tubeless tire fit to the tire not tight, you can apply the rapid inflation first and then common inflation:

1. Clamp the wheel and connect the inflation hose.
2. Step down the inflation pedal to the bottom position (second gear) and quickly release the pedal when the tire is full to the position of the first gear
3. Repeat stepping the pedal for many times to confirm the pressure indicated on the pressure gauge not exceeds the pressure specified by the manufacturer.



Note: In this process, you should ensure the wheel has been tightly clamped. Or you will be in the dangerous of lose your life.

Warning! Explosive !

When inflating, please obey the following instructions:

\*Carefully check if the tire and the rim are of the same dimension and check the wear condition of the tire to confirm the tire not damaged before inflation.

\* When the air pressure needed for inflation relatively high, you can take off the tire and to inflate under the protective cover.

\* When inflating the tire, please be carefully. Keep your hands and body away from the tire.

## Chapter V MAINTANENCE & REPAIR



NOTE:

Only the qualified professional personnel can execute the maintenance. Before any maintenance, Cut off the power .And ensures the maintenance personnel can take charge of the power plug. Meanwhile, cut

off the air supply and push the air supply switch to the off position and completely deflate the residual air in the machine. To correctly use the tire changer and prolong its working life, it is necessary to periodically maintenance and repair according to the instruction manual. Or the running and reliability of the machine will be affected and the personnel near the machine or the operator will be injured.

The following position should be monthly maintenance:  
Keep the machine and working area clean.

Use the diesel oil to clean the hexangular shaft (FIG24), Use the machine oil to lubricate.

Use the diesel oil to clean the turntable claw and its guide and use the lithium base oil to lubricate (FIG25),

Periodically check the lubrication oil level in the oil fog device. If the oil level lower than the oil scale, please feed in the SAE30 lubrication oil in time (FIG 26)

Periodically drain out the water and impurity in the oil water separator.

Periodically check and adjust the tension of the driven belt. Properly adjust the adjust nut in A and B to realize the proper tension. (FIG27) .

Check all the connect parts and tight the loosen bolt.

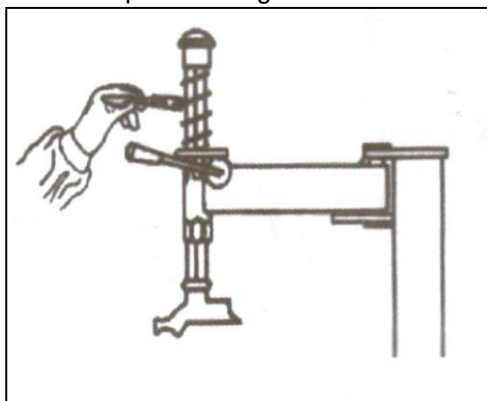

FIG 24

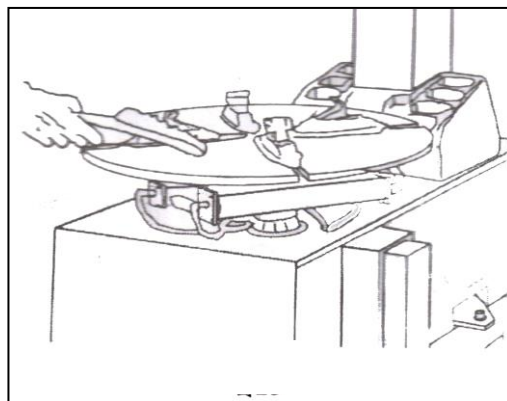

FIG 25

### HEXANGULAR SHAFT & LOCK PLATE LOCK GAP ADJUSTMENT

When press downward the hexangular lock handle, the hexangular shaft will vertically slide under the effect of the weight of the hexangular shaft and return spring. When the lock handle rotate clockwise for about 100 degree, the cam connected to the handle will push up the lock plate to lock the hexangular shaft. If you can not realize this situation, you can reach the target to lock the hexangular shaft through adjusting the position of the screws and nuts. (FIG 28)

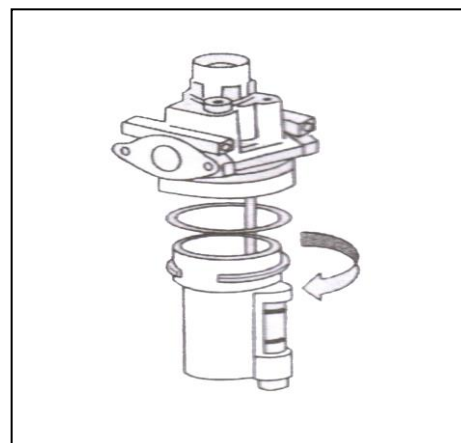

FIG 26

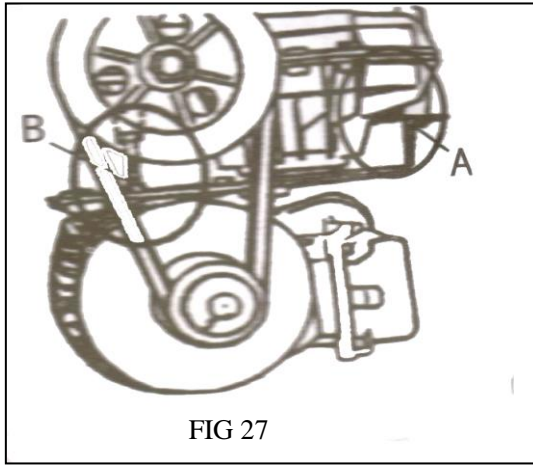

FIG 27

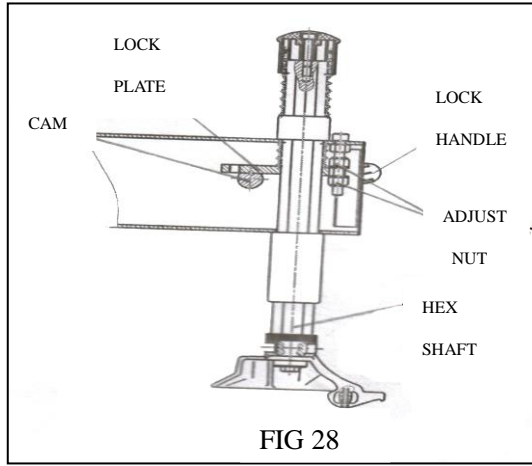

FIG 28

## CHAPTER VI INSTALLATION & OPERATION OF THE ASSISTANT ARM

### 6.1 INSTALL THE LEFT ASSISTANT

6.1.1 PL330 left assistant can be equipped on the tire changer which can handle the tire with the diameter of 20" to help complete the demounting the stiff and low profile tire. We can use it to handle the work which is difficult and impossible to do only by the operators.



Before installation, the power and air source must be cut off !

6.1.1 The left and right side of the base plate of body of the tire changer which can handle the tire with the diameter of more than 20" all have the installation hole for the left assistant prepared. Before installation, you can remove the side panel and take off the installation rubber plug. If there being the tool box, you should detach the tool box.

6.1.2 Detach the package of the PL330 assistant. Check the accessory according to the pack list. After confirmation, take out the base assembly (FIG 29) and install the screw and washer on it.

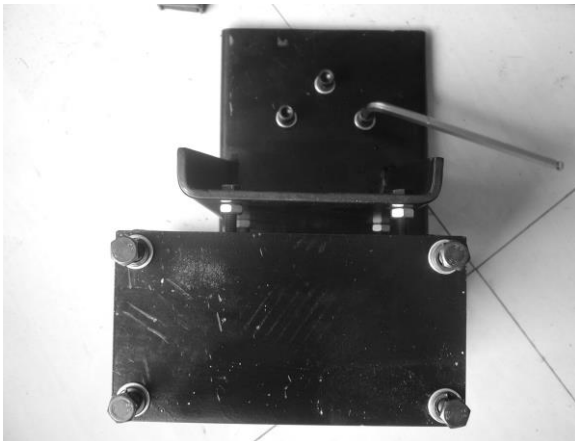

FIG 29

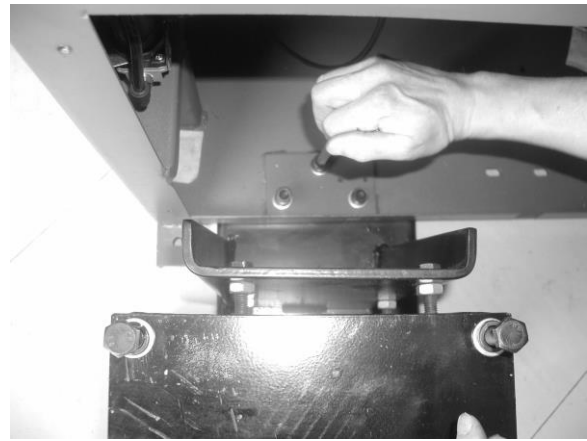

FIG 30

6.1.3 Push the platform of the base plate of the base assembly into the body through base plate on the left-back side of the body. Align the thread hole to the reinforce hole and use the bolt and washer to fix. (FIG 30) .

6.1.4 Install the body bracket (FIG 31-1) on the seat assembly. Align. Use the screw removed before to fix and not tighten

6.1.5 Use the fix supporting bracket (FIG 32) to connect the body bracket and the body and insert the screw to fix.

6.1.6 Connect the air source hose (FIG -2) and use Y Tee to connect the outlet hose and the other end connect with



the inlet of the assistant pressure adjusting valve.

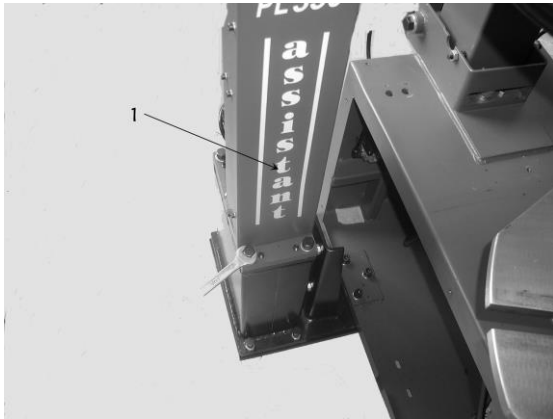

FIG 31

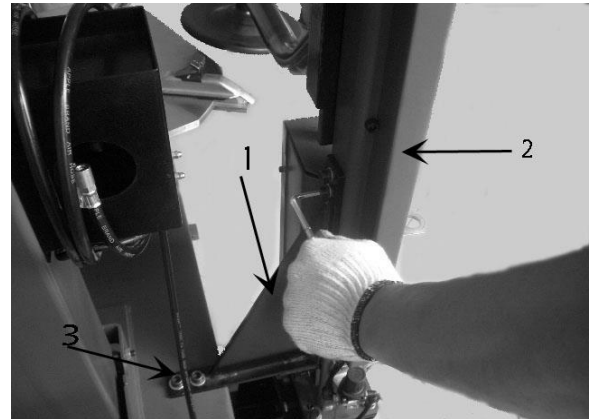

FIG 32

6.1.7 The press block includes the taper block (FIG34-1) and upper press block (FIG34-2) and the taper block can twist into the upper block. When press the rim center (FIG35), need to use the taper block and just need the upper block when do the common operation and put the taper one onto the bracket(FIG37).

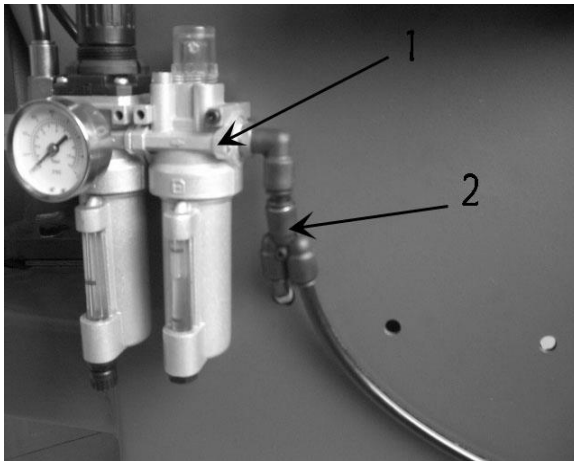

FIG 33

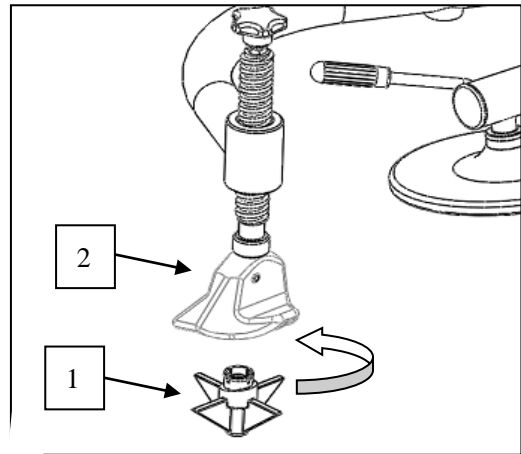

FIG 34

6.1.8 According to the FIG36, fix the fix bracket on the body and fixes the tool box on the fix bracket and then use the lock nut to tight.

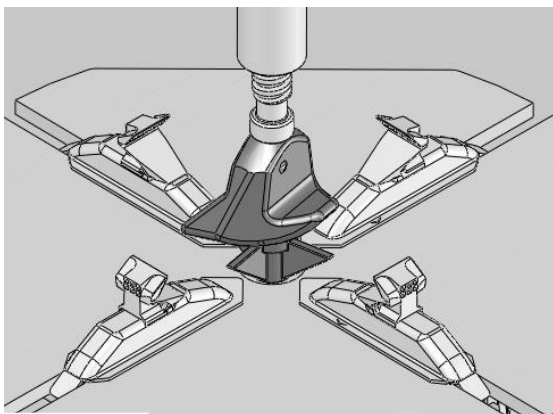

FIG 35



FIG 36

6.1.9 Loose the nut below the base and turn the screw clockwise until it against the ground and tight ( FIG38 ) and install The side panel and tool box removed in the 6.1.1. At this moment, the installation of the left assistant completed.

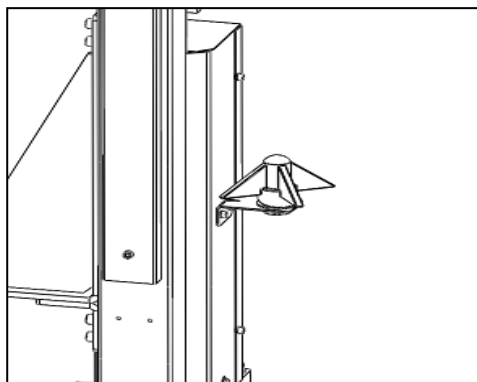

FIG 37

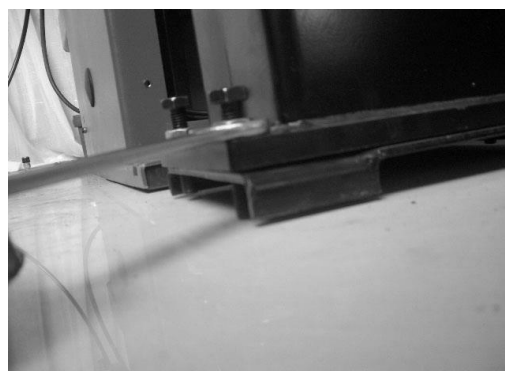

FIG 38

## 6.2 USE THE LEFT ASSISTANT

6.2.1 After detach the tire from the rim according to the instruction of the chapter IV, we can execute the following operations.

6.2.2 First, position the claw according to the dimension of the tire and then clamp the rim by the claw and position the tire press cone roller at the center of the rim ( FIG 39 ). Push down the manual valve to press down the rim until the external rim of the rim is lower than the surface of the claw. At this moment, you can immediately lock the rim. Lift up the support arm and place it at the working position and take off the press cone roller and place it on the support.



FIG 39

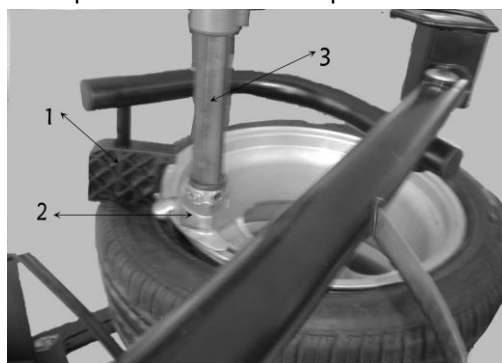

FIG 40

6.2.3 Use the press ( FIG 40-1 ) to press down the tire section by section rim detached from the mouth and use the brush to spread the lubricant on edge of the lip. Position the demount tool ( FIG 40-2 ) in the demount position. Place the press beside of the demount tool to press down the lip and insert the crowbar below the demount tool in between the rim and lip ( FIG 41 ), Lift up the press and move it to the position opposite to the demount tool and press the lip into the tire detach groove and then rotate the crowbar to lift the lip onto the demount tool ( FIG 42 ). Rotate the turntable to detach the upper lip.

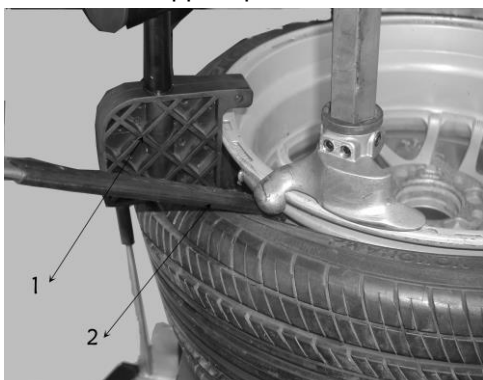

FIG 41



FIG 42

6.2.4 DETACH THE LOWER LIP: Use the disk to lift up the bottom of the tire from the bottom of the mouth ( FIG 48 ) and detach the lower lip ( FIG 43 ) according to the step ( 4.1.5 ) .



FIG 43



FIG 44

6.2.5 MOUNT TIRE

First, according to the step ( 4.2.1 ) ~ ( 4.2.3 ) , install the lower lip and use the press to press the lower lip as shown In the FIG 45. Rotate the turntable by about 90°. And then clamp the press in the demount tool ( FIG 46 ) and continually rotate the turntable until the completion of the operation.6.2.5



FIG 45



FIG 46

**CHAPTER VIII TRANSPORTATION**

When transport the machine must apply the original package and place according to the mark on the package. The machine must be transported by the forklift with the corresponding tonnage ( FIG69 ) and the stacked layer will not exceed 3layers.

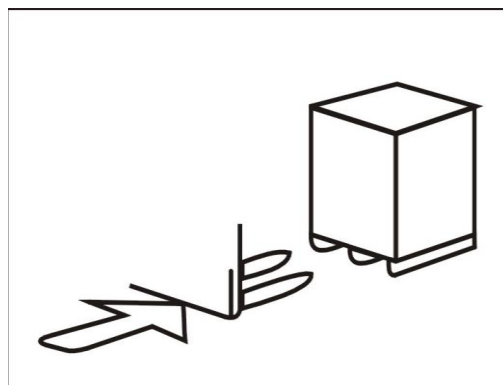
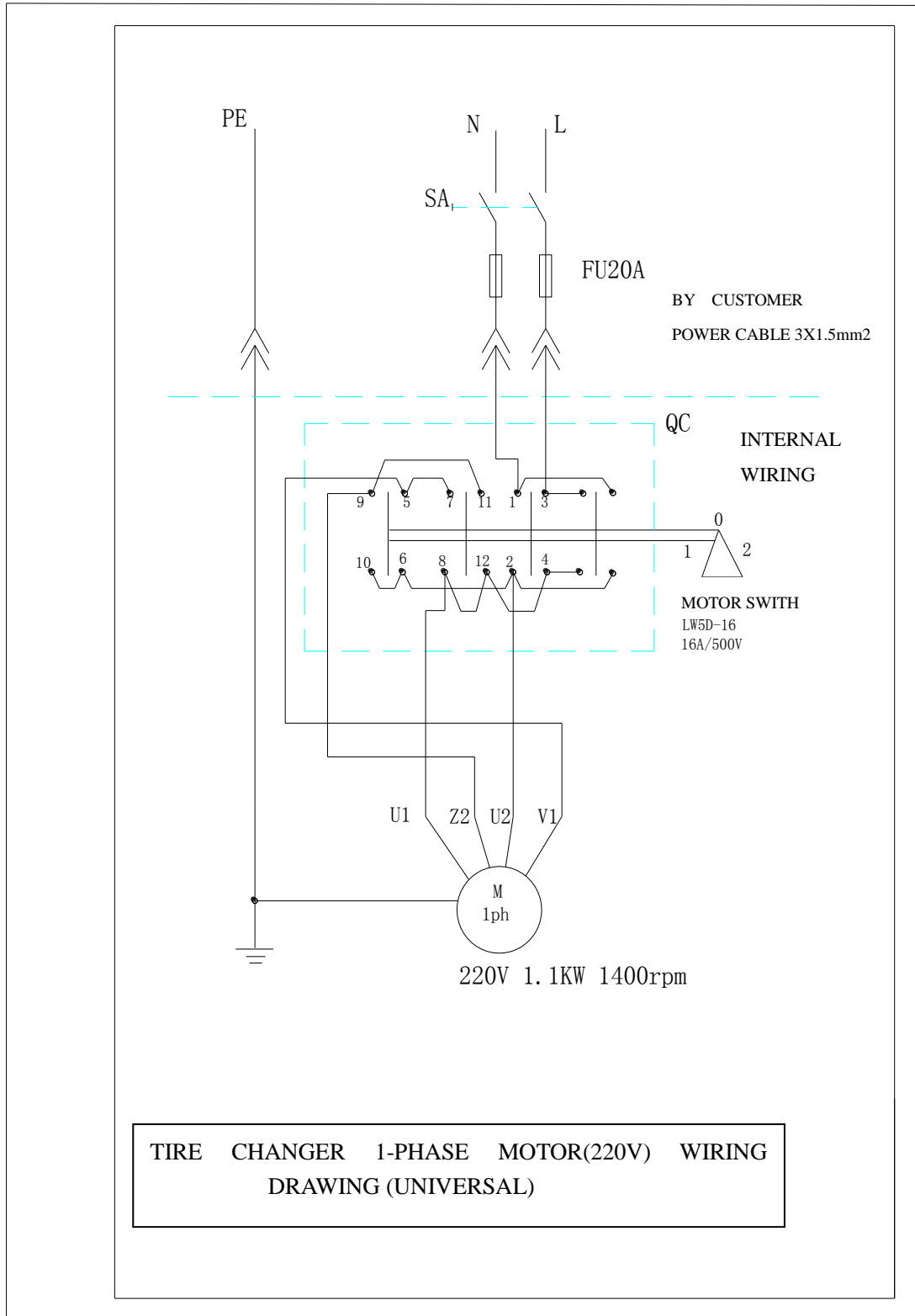

FIG 47

CHAPTER VIII ELECTRICAL AND PNEUMATIC DRAWING

8.1. 220V ELECTRICAL PRINCIPLE DRAWING





8.3.110V/220V ELECTRICAL PRINCIPLE DRAWING

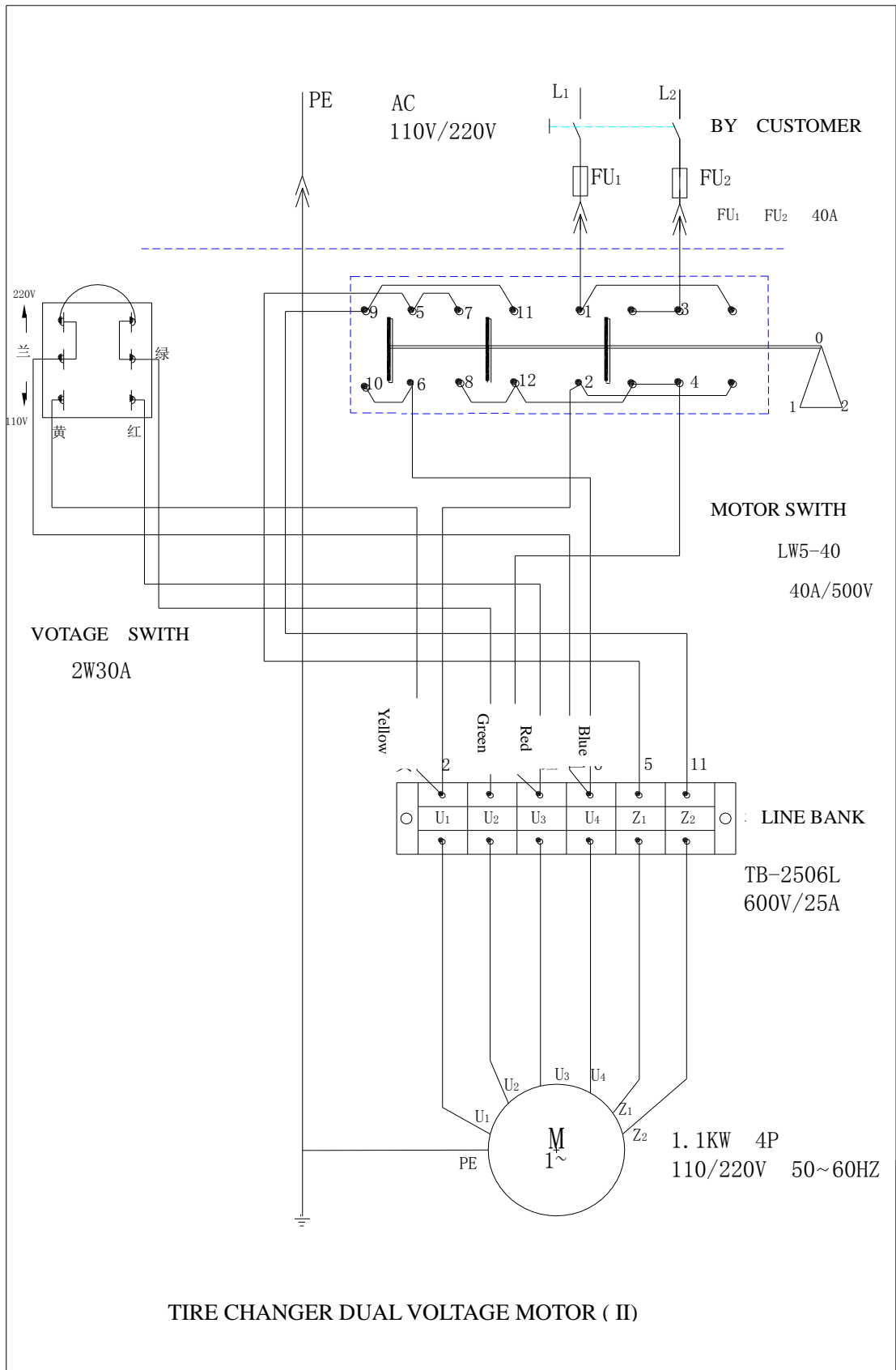

8.4. PNEUMATIC PRINCIPLE DRAWING

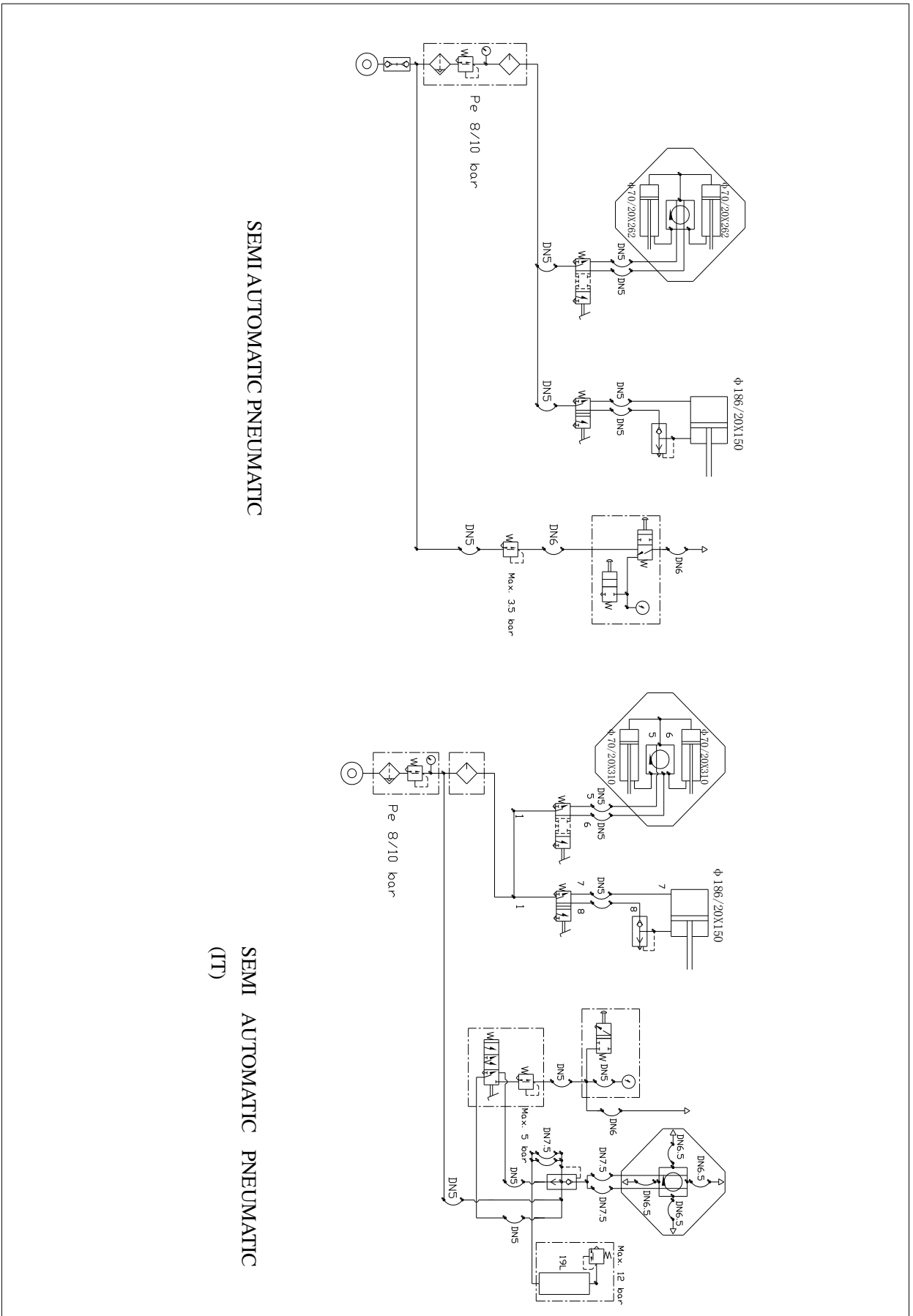

0	1	2	3	4	5	6
FILTER- GROUP	TILTING	LOCKING RIMS	BEAD BREAKER	ARM LOCKING	TIRE GAUGE	BEAD SEATER
RISE DESCENT	OPEN CLOSED	OPEN CLOSED	OPEN CLOSED	LOCKING DECHUCKING		

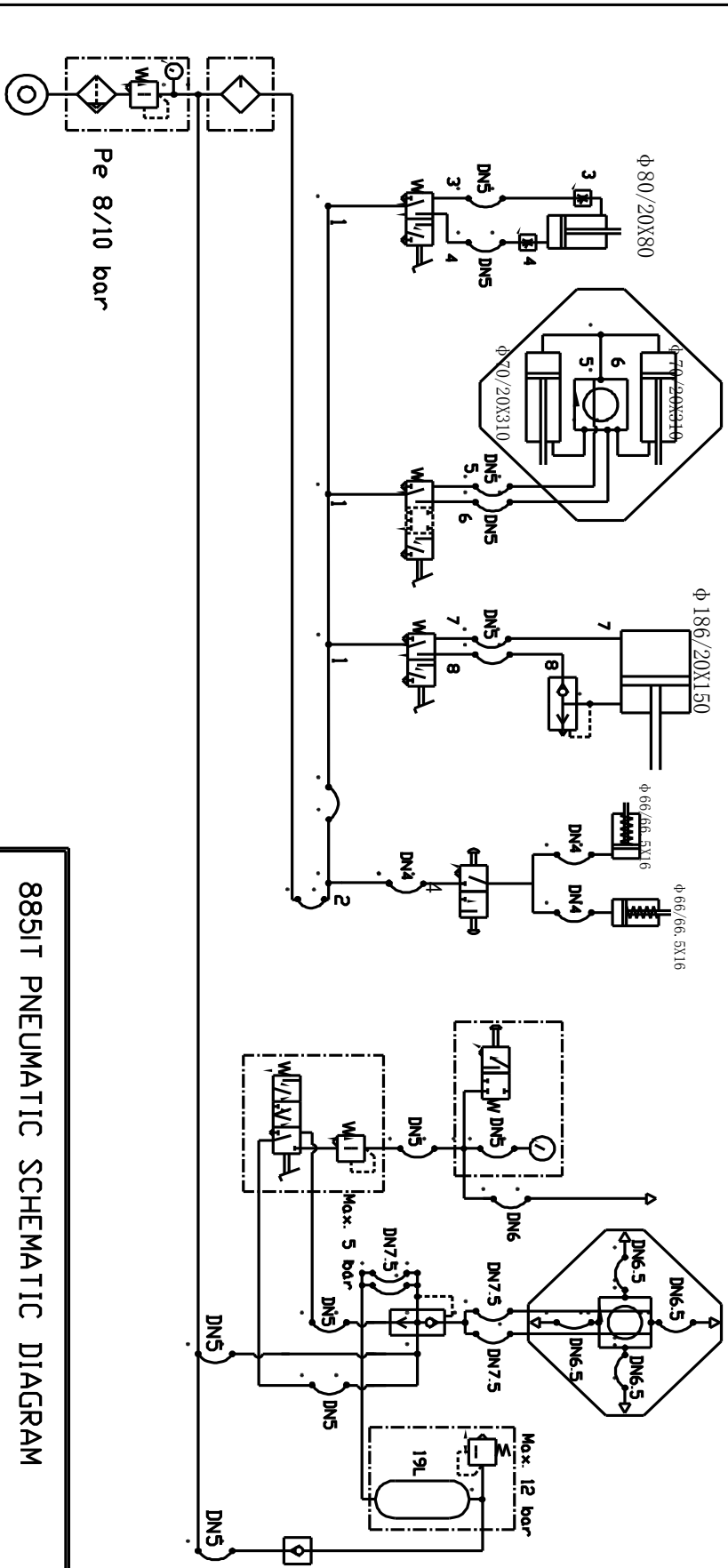

8851T PNEUMATIC SCHEMATIC DIAGRAM



## CHAPTER IX TROUBLESHOOTING ANALYZE AND SOLUTION

CHAPTER	REASON	TROUBLESHOOTING
Turntable rotates in one direction.	Universal switch contact burned	Change Universal switch
Turntable does not rotate.	Belt damage Belt too loose Motor or power source have problems  Universal switch contact damage	Change belt Adjust the tension of the belt Check motor, power source and power source cable Change motor if motor burned Change Universal switch
Turntable can not clamp the rim as normal	Claw worn Clamp cylinder air leakage	Change claws Change the air leakage sealing parts
Quadric and hexangular shaft cannot lock	Lock plate not in position	Refer to the chapter V
Chassis pedal not return.	Pedal return spring damage	Change torsion spring
Motor not rotate or the output torque not enough	Drive system jam Capacitor broken down Voltage not enough Short-circuit	Remove the jam Change capacitor Wait for the restore of the voltage Remove
Cylinder output force not enough	Air leakage Mechanic fault Air pressure not enough	Change sealing parts Remove the fault Adjust the air pressure to meet the requirement
Air Leakage	air hose broken pipe fitting broken sealing head broken loss of the sealing glue	Change broken parts   Refill the sealing glue

## LC SERIES MACHINE OIL SAFETY DATA SHEET

### MOBIL XHP 222

ITEM	QUALITY STANDARD
Penetration rate 25°C mm/10	280
dropping point °C	280
anticorrosion	passed
Basic oil viscosity	220
oxidize stability 100h pressure-drop kpa	35
water lose percentage 79%	5
copper corrosion	1A

### SAE30# LUBRICATION OIL

ITEM	QUALITY STANDARD
density 15°C	0.893
Flash point	224
Pour point °C	-18
viscosity 40°C	100
viscosity 100°C	11.2
Viscosity index	97

### 2# LITHIUM BASE GREASE

ITEM	QUALITY STANDARD
Penetration rate mm/10	278
dropping point °C	187
copper corrosion 100°C 24 h	No change
oxidize stability (99°C 100 h)	0.2
anticorrosion (52°C 48 h)	1 level
similarity viscosity (-15°C、 $10S^{-1}$ ) / (Pa·S)	800
water lose(35°C 1h) %	8

### CKC460 INDUSTRIAL GEAR OIL

ITEM	QUALITY STANDARD
Viscosity 40°C	461
Viscosity index	92
Flash point °C	212
Freezing point °C	-26
copper corrosion 100°C 3 h	1A
mechanical impurity	0.007
Pour point	-10