



Dear customers,

Very pleased that you will purchase and use the tire changer produced by our company.

We are the company with reputation of quality. We sincerely wish to produce quality goods under the ISO9001 Quality system and get the EU CE certificate to help you promote your business.

Carefully read this operational manual before installation and use this operation manual. And also keep it with care for future reference.



**Warning**

- This instruction manual is the important part of the product. Please read it carefully.
- Keep it properly in order to maintain and service.
- This machine is only applied to mount, demount and inflate the tire in the specified scope and not for any other purpose.
- The manufacturer will not be responsible for the damage arising from the improper operation.

## NOTE

- This machine should be operated by the special trained qualified personnel. When operating, the unauthorized personnel will be kept far away from the machine.
- Please note the safety label stuck on the machine.
- Operators should wear safety protective facilities such as working suit, protective glasses, and eye plug and safety shoes. Keep your hands and body from the movable parts as possible as you can. Necklace, bracelet and loosen clothing may cause dangerous to the operators.
- Tire changer should be installed and fixed on the flat and solid floor. The more than 0.5m of distance from the rear and lateral side of the machine to the wall can guarantee the perfect air flow and enough operation space.
- Do not place the machine in the site of high temperature, high humidity, and dust and with flammable and corrosion gas.
- Without the permission from the manufacturer, any change on the machine parts will cause injury/damage to the machine/operator.
- Pay special attention that the tire changer should be operated under the specified voltage and air pressure.
- If you want to move the tire changer, you should under the guidance of the professional service personnel.

## SAFTTY LABEL INSTRUCTION



Electrical shock !



Do not reach any part of your body under the demount tool.



When breaking bead, the bead breaking blade will quickly move leftwards.



Do not stand behind the column to avoid the column from injuring the persons when swing.



Pay attention to your hands



When rapid inflation, ensure the wheel clamped.

When operation, do not wear long hair, loosen clothing and jewelries.

When operation, not reach your hand under the falling objects.

# Safety Label Position Diagram

- Pay attention to keep the safety labels complete. When it is not clear or missing, you should change the new label.
- You should let the operators see the safety labels clearly and understand the meaning of the label.

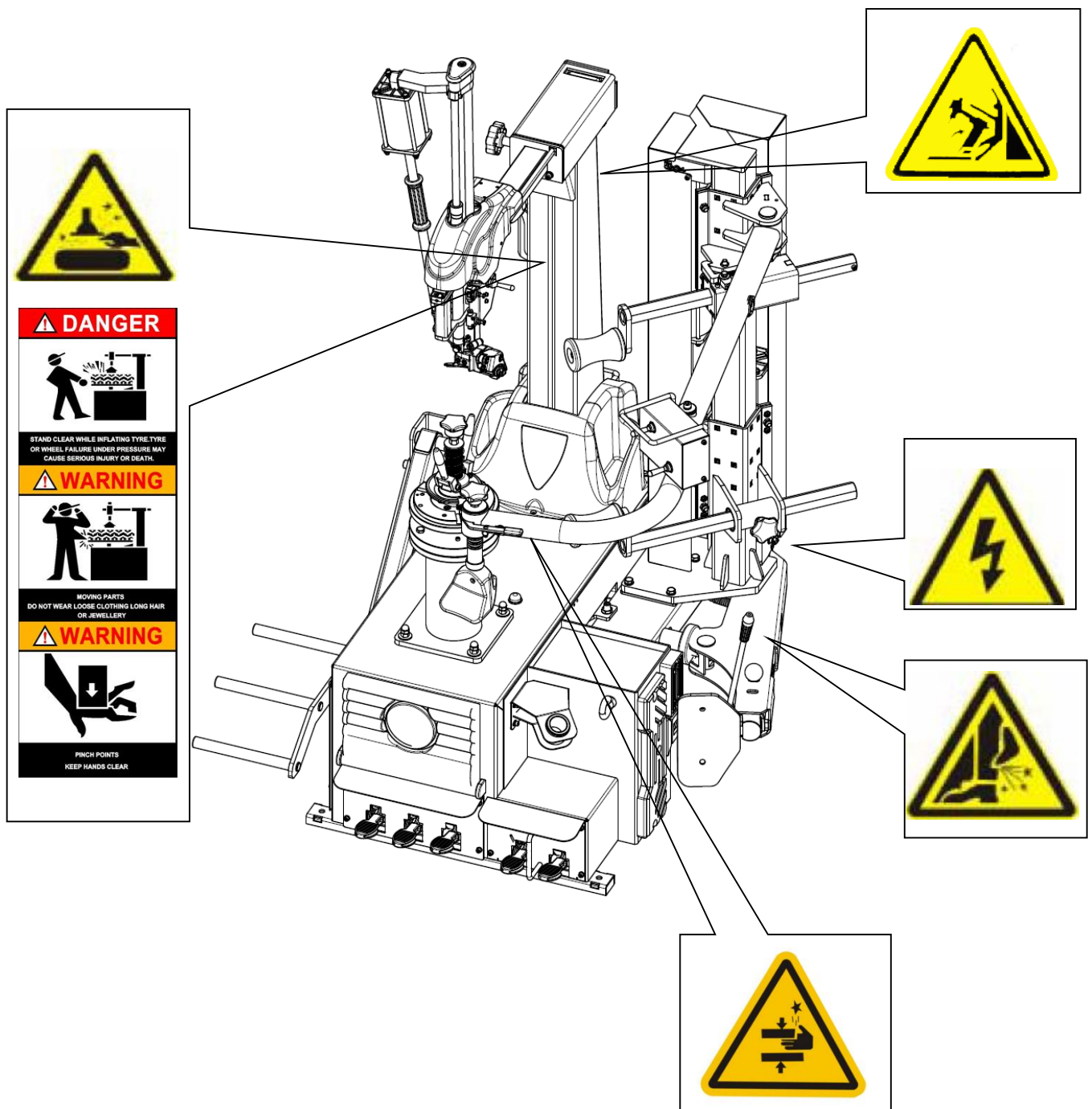

# Content

## **Chapter 1 Brief Introduction**

1.1 brief introduction

1.2 overall dimension

1.3 technical parameter

1.4 application

1.5 work environment

## **Chapter 2 Basic Construction and Operational parts**

## **Chapter 3 Installation and Commission**

3.1 unpacking

3.2 installation of the parts detached

3.3 air test

## **Chapter 4 Demount/Mount**

4.1 basic principle

4.2 demount tire

4.3 mount tire

4.4 inflation

## **Chapter 5 Repair and Maintenance**

## **Chapter 6 Electrical and pneumatic principle diagram**

## **Chapter 7 common troubleshooting and solution**

## CHAPTER 1 BRIEF INTRODUCTION

### 1.1 brief introduction

The tire changer is the tire changer featured with tilt column, Italy lever-less technic and horizontal arm, suitable to mount, demount and inflate all types of car tire with tube and tubeless. The operation is easy, convenient and safety. It is the necessary equipment for the auto service shop and tire shop. 889NV can also be equipped with the assist arm, making it easier and more efficient to mount/demount low profile, hard and RSC tires easier. For the kinds of optional assist arm, please consult the local dealers.

### 1.2 overall dimension and weight

L max (mm)	W max (mm)	H max (mm)	N/W kg
1750	2300	2040	420

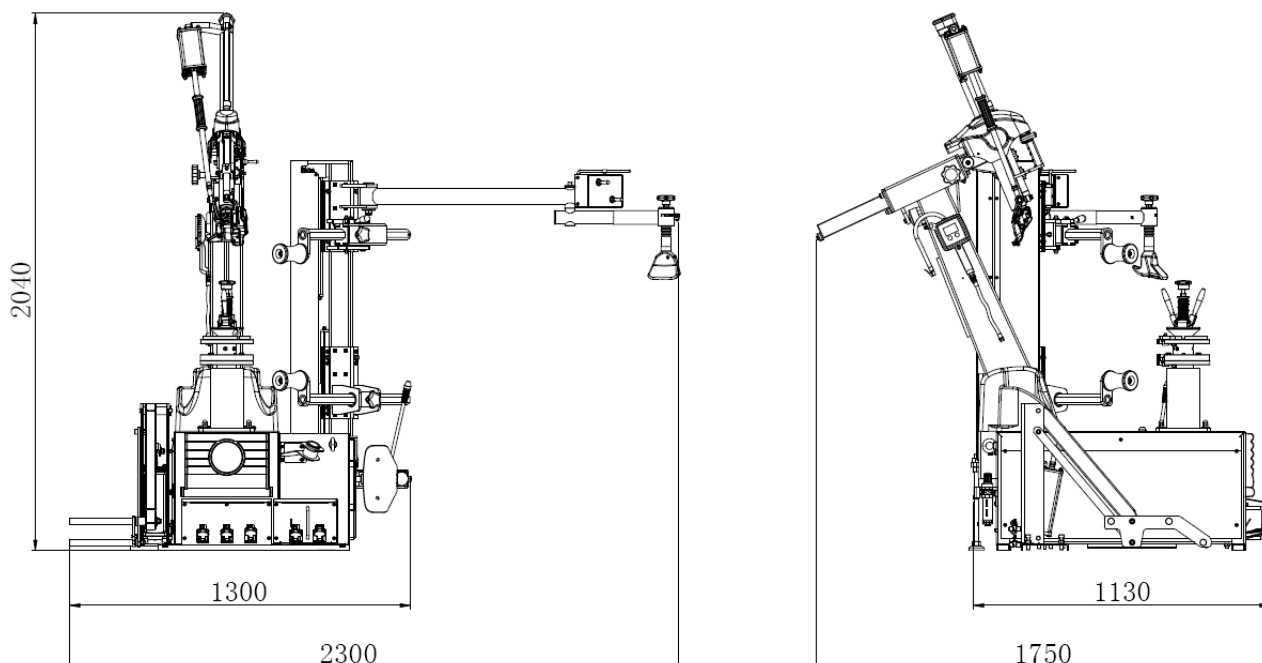

### 1.3 technical parameter

Work pressure: 8-10bar

Motor parameter: choose the motor with different parameter according to customer's requirement.

50Hz/60Hz, 0.75-1.1KW, 110-380V

Turntable speed: 6.5rpm

Working Noise: <70dB

### 1.4 Scope of application

Max. wheel diameter	Max. wheel width	Rim diameter
1120mm (44" )	356mm (14" )	12" ~ 30"

1.5 working environment requirement



Forbidden to be used in the place containing the gas flammable!

Environment temperature: 0°C~45°C ; Relative humidity: 30~95%; Max. Altitude: 1000M; without dust and without gas easy to explosive and rusty. The space around machine is not less than indicated in Fig2.

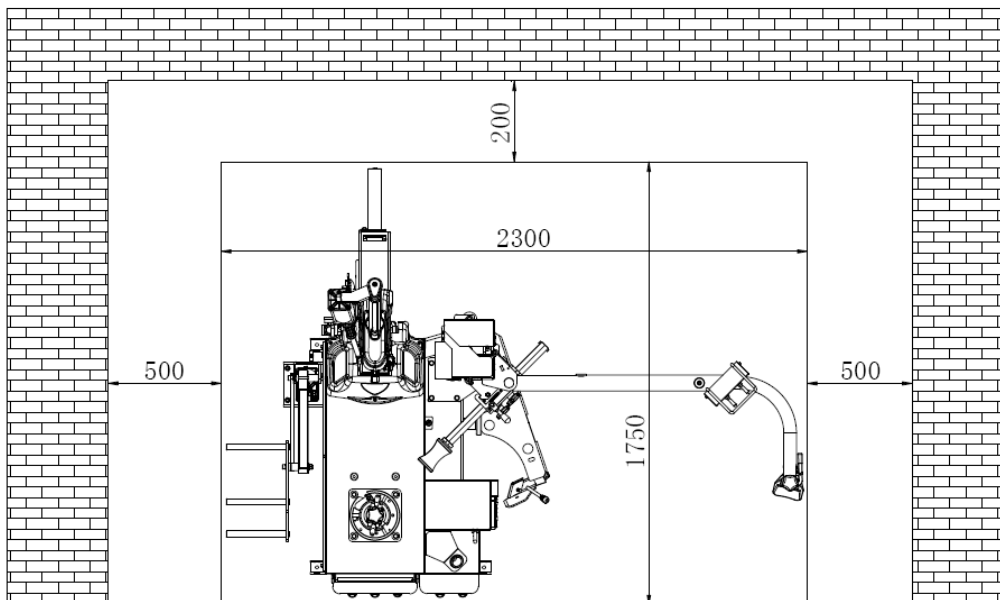

FIG1



## Chapter 2 Basic Construction and Operational parts

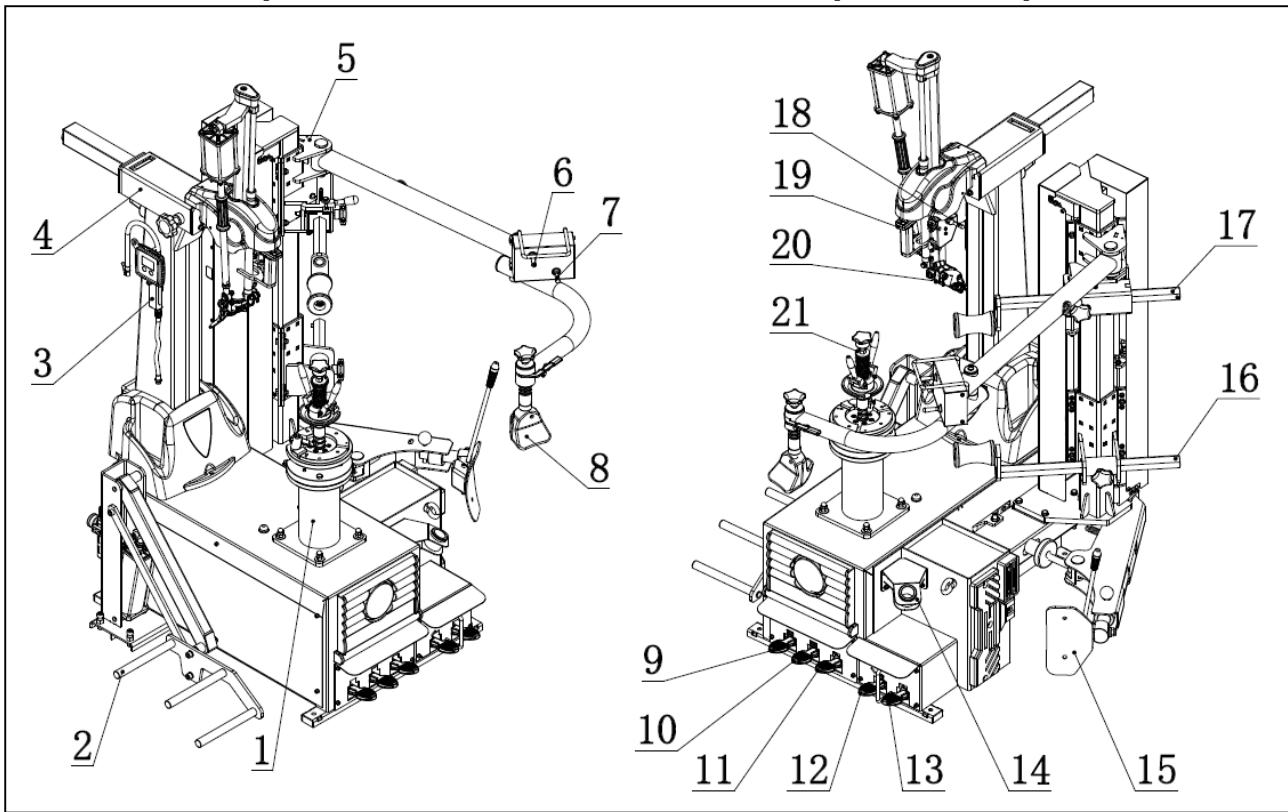

FIG2

1 main shaft    2 lifter    3 inflation gun    4 vertical arm    5 assistant arm    6 control valve of upper press rod    7 control valve of lower press rod    8 rotation press plate    9 pedal of lifter for upward movement    10 pedal of lifter for downward movement    11 tilt pedal    12 rotation pedal    13 bead breaker pedal    14 thread rod bracket    15 bead breaker blade    16 lower press rod    17 upper press rod    18 lifting valve of demounting hook    19 control handle valve on horizontal arm    20 demounting hook    21 thread rod assembly

## Chapter 3 Installation and Commission



Carefully read the manual before installation and the change on the parts of the machine without the permission of the manufacturer can cause the damage to the machine;

- Installation and commission person must have some knowledge relating to electrical;
- Operator must under the special training and pass the examination;
- You must carefully check the equipment list and contact the dealers or our company if you are in doubt;
- When transport the machine must apply the original package and place according to the mark on the package. The machine must be transported by the forklift with the corresponding tonnage (Fig3) and the stacked layer will not exceed 3 layers.

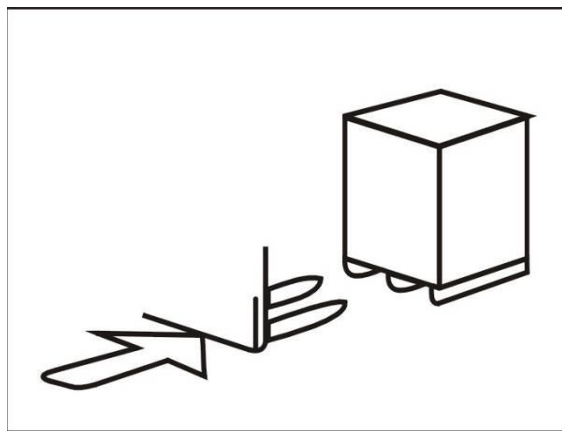

**FIG3**

### 3.1 Open the box

- In accordance with the instruction on the package box, open the package box and remove the package material and check if the machine is sounded and the accessories if completed.
- Keep the package material far away from the working site and treat it well.
- The machine must be fixed onto the flat and firm ground with the four-foot margin.

### 3.2 install the tire lifter (ignore this step if entire machine packing)

- Connect the tire lifter and rod using M12x110 screw, M12x50 screw, flat washer and M12 lock nut like the fig4. Note: do not tighten fully the two nuts. Make sure there's proper gap among every rotation part in order to rotate freely.

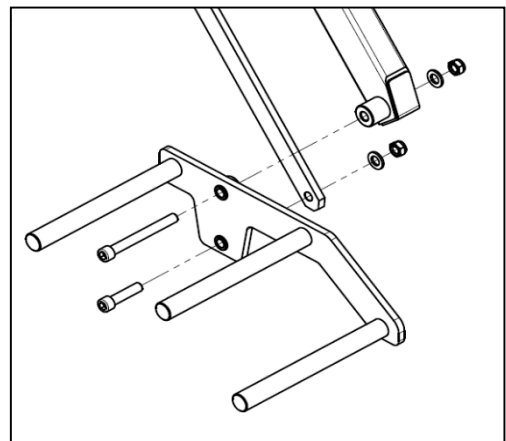

**FIG4**

### 3.3 connect the power supply and air supply

- Make sure the power supply on the operation site is consistent with the parameter of the motor on the equipment before connect the power supply and the power supply must have a grounding wire. The equipment should also be reliably grounded. After connecting the power supply, step the rotation pedal (FIG2-12) of main shaft to confirm there's no abnormality in rotation direction of the main shaft.
- Before the machine out of the factory, the air regulator has been adjusted well and can be re-adjust if need.

Adjust the pressure: lift-up the adjusting knob (FIG5-B) and rotate it clockwise, the pressure will raise. Otherwise, decline. Press down the adjusting knob after adjusting.

Adjust the oil feed: twist the adjusting screw (FIG5-A) clockwise using the screw driver to slow the dripping speed and otherwise, quicken it.

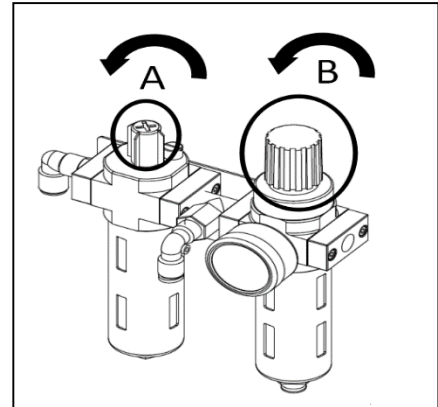

FIG5

- Press the button of horizontal arm control handle valve (FIG2-19) to lock the horizontal arm. Step the tilt pedal (FIG2-11), the vertical arm will tilt backward about 25°. The movement speed of the column has been adjusted to one-way movement for about 2 seconds before leaving the factory. If the speed is too fast or too slow after using for a long time, the air adjusting valve on the chassis can be used to adjust the air flow of the pull-out cylinder: loosen the nut, turn the adjusting screw clockwise to slow down the speed, and turn anticlockwise to speed up.
- Pull the lifting control valve (FIG2-18) of demounting hook to confirm there's no abnormal lifting of the demounting hook.
- Step the upward pedal (FIG2-9) and downward pedal (FIG2-10) of the tire lifter to confirm that there's no abnormal lifting of the tire lifter.
- Step the pedal (FIG2-13) of bead breaker blade to confirm that there's no abnormal of bead breaker cylinder.
- Pull the upper press rod control valve (FIG2-6) and the lower press rod control valve (FIG2-7) of the assistant arm to confirm that there's no abnormal of the upper and lower rod lifting movement.

## Chapter 4 Demount/Mount



Note: the operator must be trained and qualified then allow to operate the tire changer. Need to use the proper device and tools, wear the protective clothes, and use the proper safety precautions, like goggle, earplug, and safety shoe and so on.

### 4.1 BASIC PRINCIPLE

- In order to avoid damage the rim, especially the alloy rim, when mount and demount the tire, must use the specified crowbar.
- In order to facilitate the removal and protection the tire and rim, between the tire and rim, at the position which the bead break blade insert to, need to lubricate using industrial lubricants or soap water.
- For certain types of tires, pay attention to the tire wall and the rotation direction marked on the tire.
- The tire size must be suitable for the rim to mount.
- Before mount and demount the tire, need to check whether the rim had damage (deformation or surface of the outside of the rim, rim axial for radial beat is too big, corrosion or overall wear).
- In any case, pay attention to the mounting and demounting request of the special tire from the tire manufacturers.
- When inflate the tire, to increase the pressure uniformly and pay attention to the tire edge situation.

### 4.2 Demount tire

- Deflate the air in the tire completely and pull out the core. Use the special tool to detach the weight on the rim. (FIG6)

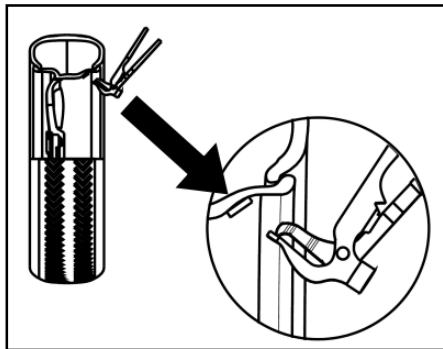

FIG6

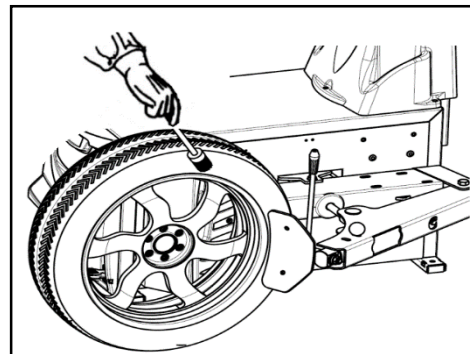

FIG7

- Place the tire between then bead breaking blade and tire pressing runner clog (FIG7). Then step down the tire press pedal (FIG2-13) to detach the rim from the tire. Repeat the same operation on the other parts of the tire to make the tire completely detached from the rim.

- Can use the adjusting device (FIG8-1) to shift the gear to suitable for the different thickness tire. Adjust the depth of bead break blade to avoid bead too deep to damage the tire or rim.

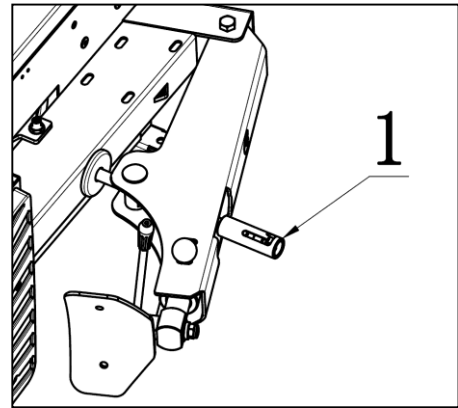

FIG8

- After bead breaking, roll the tire onto the lifter like FIG9 then step the tilt pedal (FIG2-11) to tilt backward the column. Then peel the upward pedal (FIG2-9) of tire lifter to lift the tire and turn the tire over onto the main shaft. Align the rim center hole, fixing screw holes with the main shaft center hole and the pin shaft, insert the thread rod assembly and tighten the quick nut to fix the rim like FIG10 (some special rims require more cones to fix).

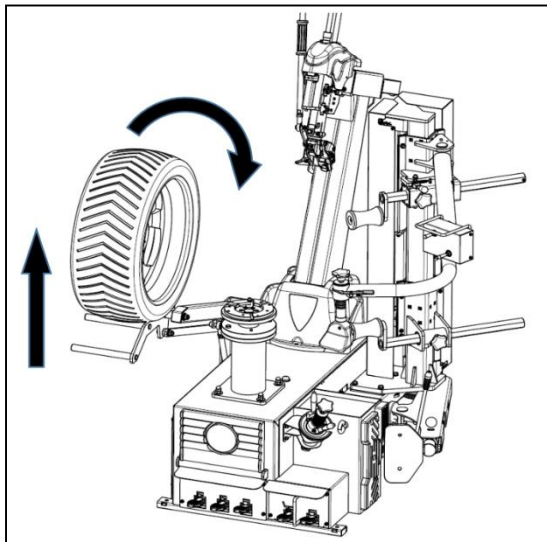

FIG9

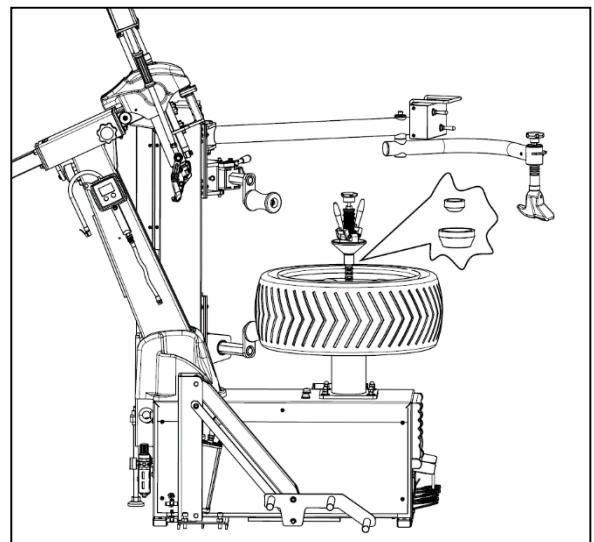

FIG10

- Return the vertical arm and press the control valve (FIG2-19) to the middle position, the demounting head should fall to the working position. Make the demount tool close to the rim of the wheel. The protection covers and plastic tail cover in the demount head will contact with the rim edge. If the tire wall is hard, use the press plate of assist arm to press the tire lop down like FIG11. Then press the control valve button to lock the horizontal arm. At this time the demounting head will move slightly away the rim automatically to separate the demounting head and rim to avoid scratching the rim like FIG12.

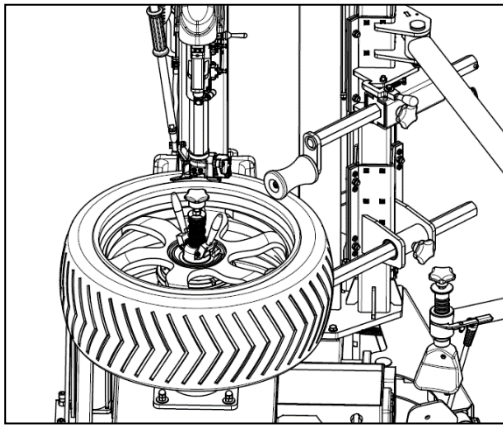

FIG11

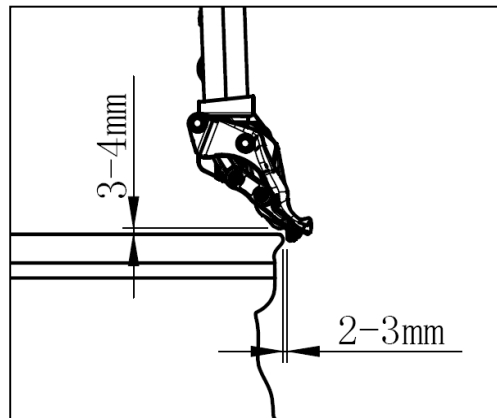

FIG12

If there has inner tube in tire, in order to avoid damage the inner tube, the demounting hook should be operated about 10cm away from the left side of the valve as shown in FIG13.

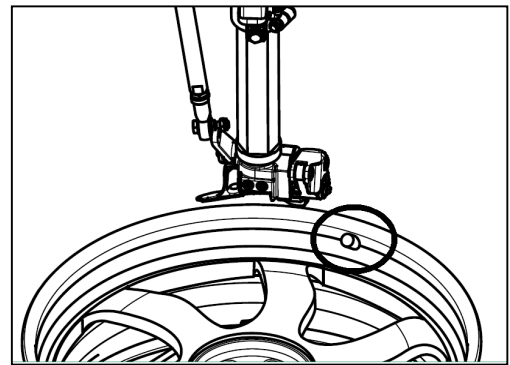

FIG13

- Pull down the control valve (FIG2-18) of demounting hook to make the demounting hook enter the inner side of tire lip. If the demounting hook does not insert into the inside of tire lip when down to the bottom, step the rotation pedal to rotate the turntable a little to make the hook insert into the inside of tire lip like the FIG14.

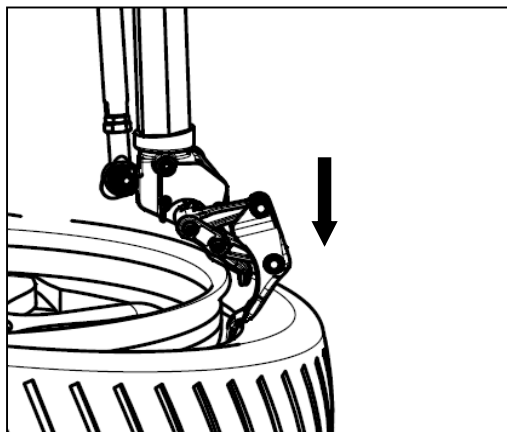

FIG14

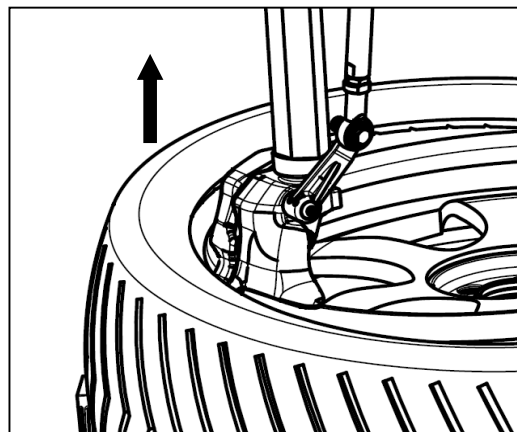

FIG15

- After the demounting head into the tire lip, pull upward the control valve to lift the tire lip onto the circular convex part of demounting head like FIG15. Currently, step the rotation pedal to observe the tire lip and demounting hook, if there's no abnormality, step down the rotation pedal to rotate the turntable clockwise to take out the upper side of tire lip.

- If the demounting hook cannot lift the tire lip because of the harder RSC tire during lifting the tire lip, can press the tire using assist arm. The pressing block can press down 4-8cm on the opposite side of the demounting head, which helps the demounting hook to lift the tire lip smoothly like FIG31.

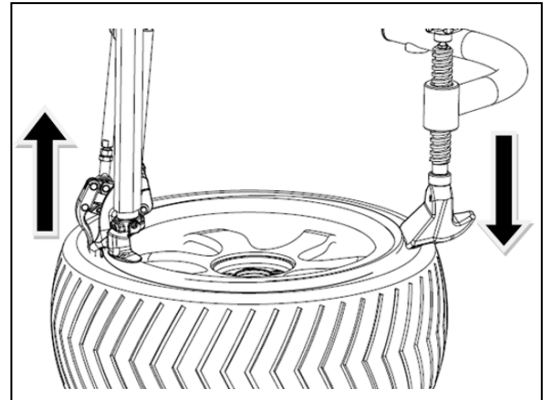

FIG16



If the demount of the tire is jammed, please stop the machine immediately and then lift up the pedal to let the turntable rotate counterclockwise to remove the resistance!

- After separate the upper tire lip, take out the inner tube if has. Lift the lower tire lip to rim edge. Lower the hook and take the lower tire lip like FIG17 then step the rotation pedal to separate the lower side.

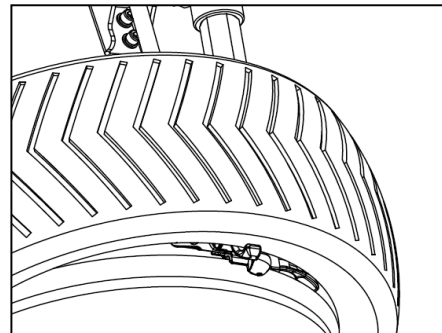

FIG17

- Then step the tilt pedal to tilt the column back and take out the tire like FIG18. Finish the demounting tire operation.

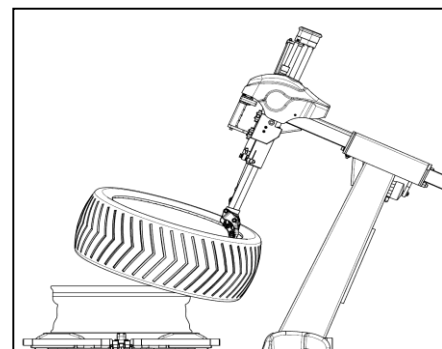

FIG18

### 4.3 Mount tire



Before mount the tire, check that the tire and rim size are the same!

- Clean up the oil and rust on the rim and lock the rim on the turntable. Note: the demount groove must be at upper side to mount. Spread the lubrication liquid or soap liquid around the lip. Tilt the tire against the rim and keep the front end upwards. Press down the column tilt pedal to make the column return to the original position. Move the demount head to firmly contacted rim. Position the left of the lip above the tail of the demount tool and the right under the hump of the demount tool (FIG19). Press down the right side of the tire as hard as you can and step turntable pedal to rotate the turntable clockwise to guide the lip into the tire detach slot completely.

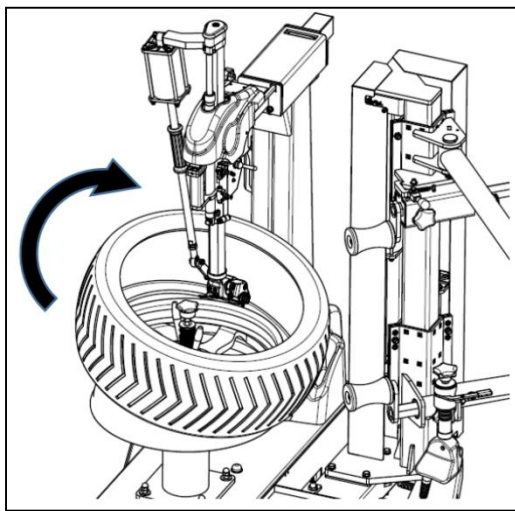

FIG19

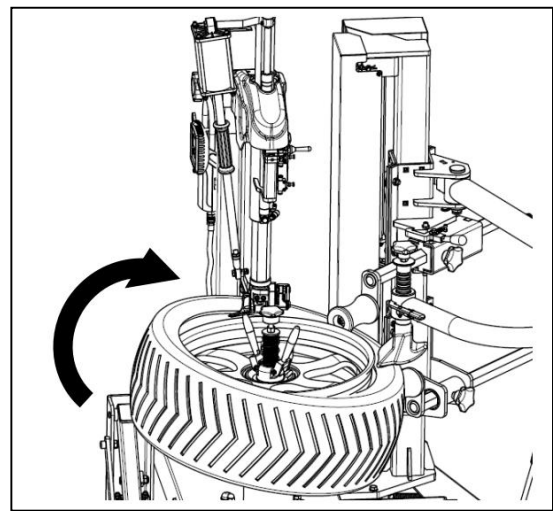

FIG20

- If there is tube, raise up the demount tool and put in the tube and position the core.
- In the same way, Position the left of the lip above the tail of the demount tool and the right under the hump of the demount tool. Press hard the right-side tire wall. If there's assist arm, need position the fixture press rod and rotation rod like FIG35 and press the tire lip down rim the tire detach slot. Then step the rotation pedal to observe the tire lip and demounting hook, if there's no abnormality, step down the rotation pedal to rotate the turntable clockwise to mount the upper side of tire lip into the rim. If there has resistance and feel the tire is torn or the turntable is stuck, please release the pedal immediately, and step the pedal upward to reverse the motor and eliminate the resistance. Repeat the operation till mount the tire completely.

### 4.4 Inflation



When inflating the tire, you should be careful and follow the operation procedure strictly. Please check whether the air connection is intact before inflating. The machine is equipped with inflation device with a pressure gauge (inflation gun or inflation gauge box), which is used for tire inflation and air pressure monitoring.





### **Warning! Explosive!**

When inflation, you must follow the above safety operation and abide by the following instruction:

- ◆ Carefully check is the size of the rim same to the size of the tire and check the wear condition of the tire to secure there is no damage before inflation.
- ◆ When the inflation pressure is relatively high, you should remove the tire from the machine and inflate in the protective cover.
- ◆ When inflate the tire, be carefully, keep your hands and body far away from the tire.

#### 4.4.1 inflation device

This machines equips the digital display inflator like FIG21.FIG21-1 inflator switch, FIG21-2 deflation button, FIG21-3 button to shift the pressure unit (the inflator has 4 kinds optional pressure unit: bar, psi, kpa, kgf), FIG21-4 digital display switch.

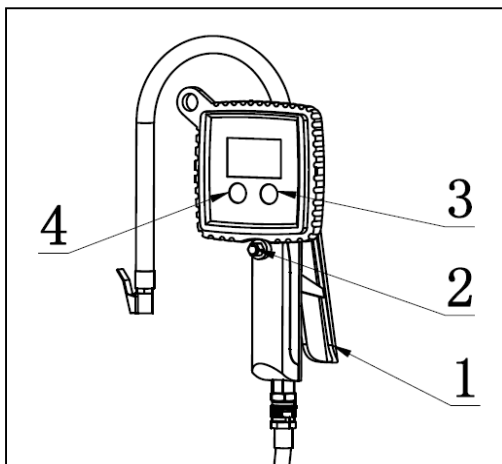

FIG21

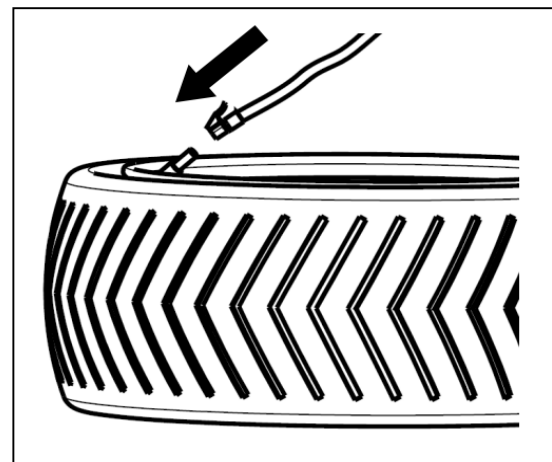

FIG22

#### 4.4.2 inflation operation

- Connect the inflation hose with the tire air core. (FIG22)
- In the process of inflation, you should repeat turn on and turn off the inflator. Confirm the pressure indicated on the pressure gauge not exceed the scope specified by the manufacturer. Normally, the tire pressure of the common tire will not exceed 3.5bar.
- If the inflation pressure too high, you can press down the deflation press button (FIG21-2) on the inflation device to reach the required air pressure.

## Chapter 5 Repair and Maintenance



Note: Only the professional personnel can repair. Before any operations of repair and maintenance, you should power off and the power plug should be monitored by the repair personnel, meanwhile switch the pneumatic source and deflate the residual gas.

In order to use the tire changer properly and extend its service life, it is necessary to repair and maintain the machine regularly according to the requirements of the manual. Otherwise, the operation and reliability of the machine will be affected and the operator or the personnel near the machine may be hurt.

### 5.1 The following parts will be maintained monthly:

- Keep the clean of machine and working site.
- Use the diesel oil to wash the hexangular shaft and quadric horizontal arm (Fig23).
- Use the diesel oil to clean the guide rail of assist arm and use the Lithium grease to lubricate. (Fig24).
- Periodically check the height of the in the oil fogger. If it is lower than the oil scale, please fill in the SAE30 grease. Periodically drill out the water and impurity in the oil-water separator. (Fig25)
- Periodically check and adjust the tension force of the transmission belt and properly adjust the adjustable nuts at the A and B position to adjust the tension of the belt. (Fig26)
- Check all the connecting part and tight the loose bolts.

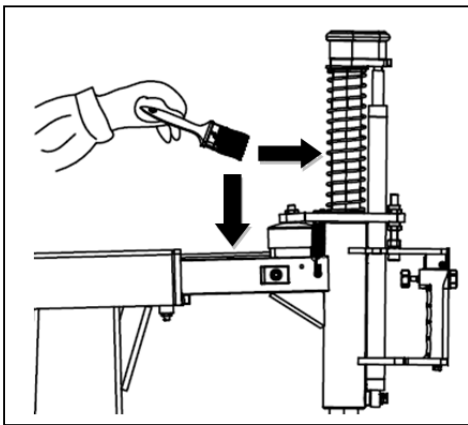

FIG23

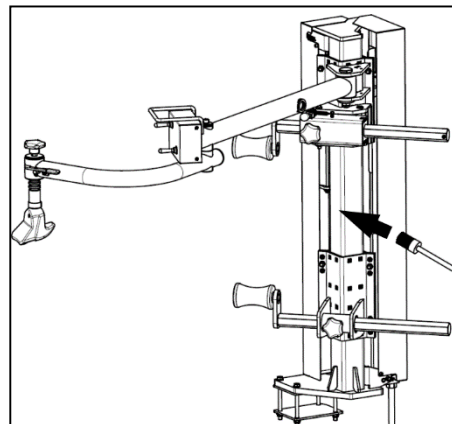

FIG24

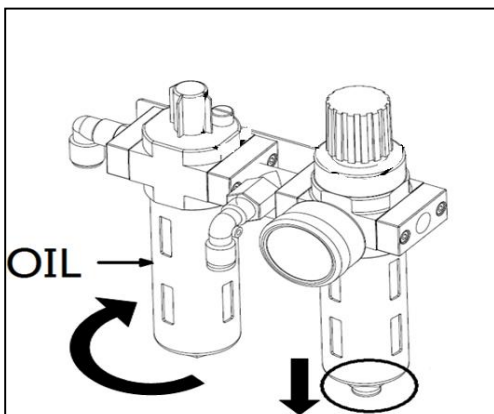

FIG25

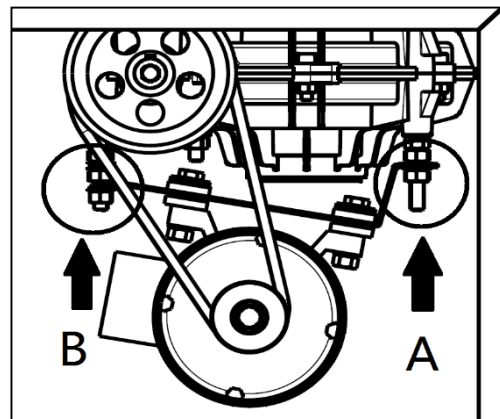

FIG26

5.2 The **adjustment on the clearance between the tool head and rim.**

- Adjust the upper and lower movement distance of hex locking plate through nut A to improve the up and down gap; Adjust the back and forth movement distance of square locking plate through screw B to improve the back and forth gap; then fix the square locking plate using screw and nut C after adjusting to avoid the shaking of horizontal arm like FIG42.

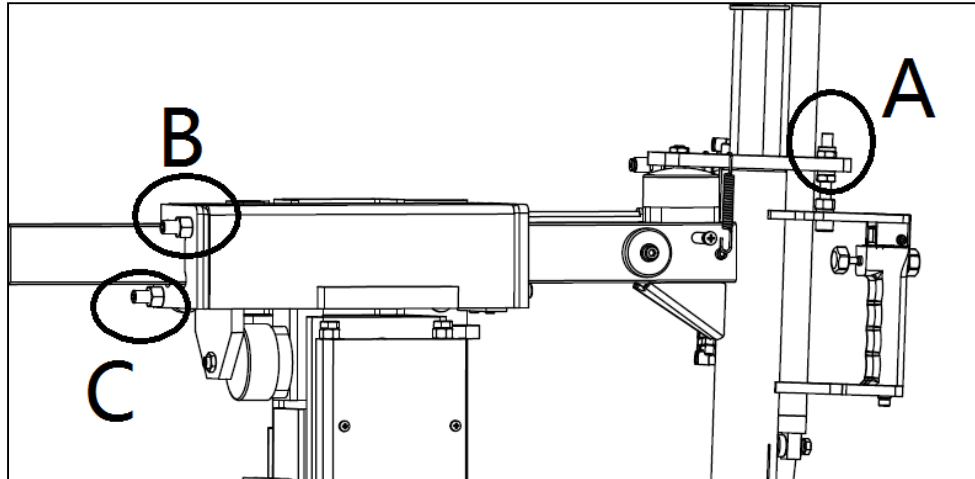
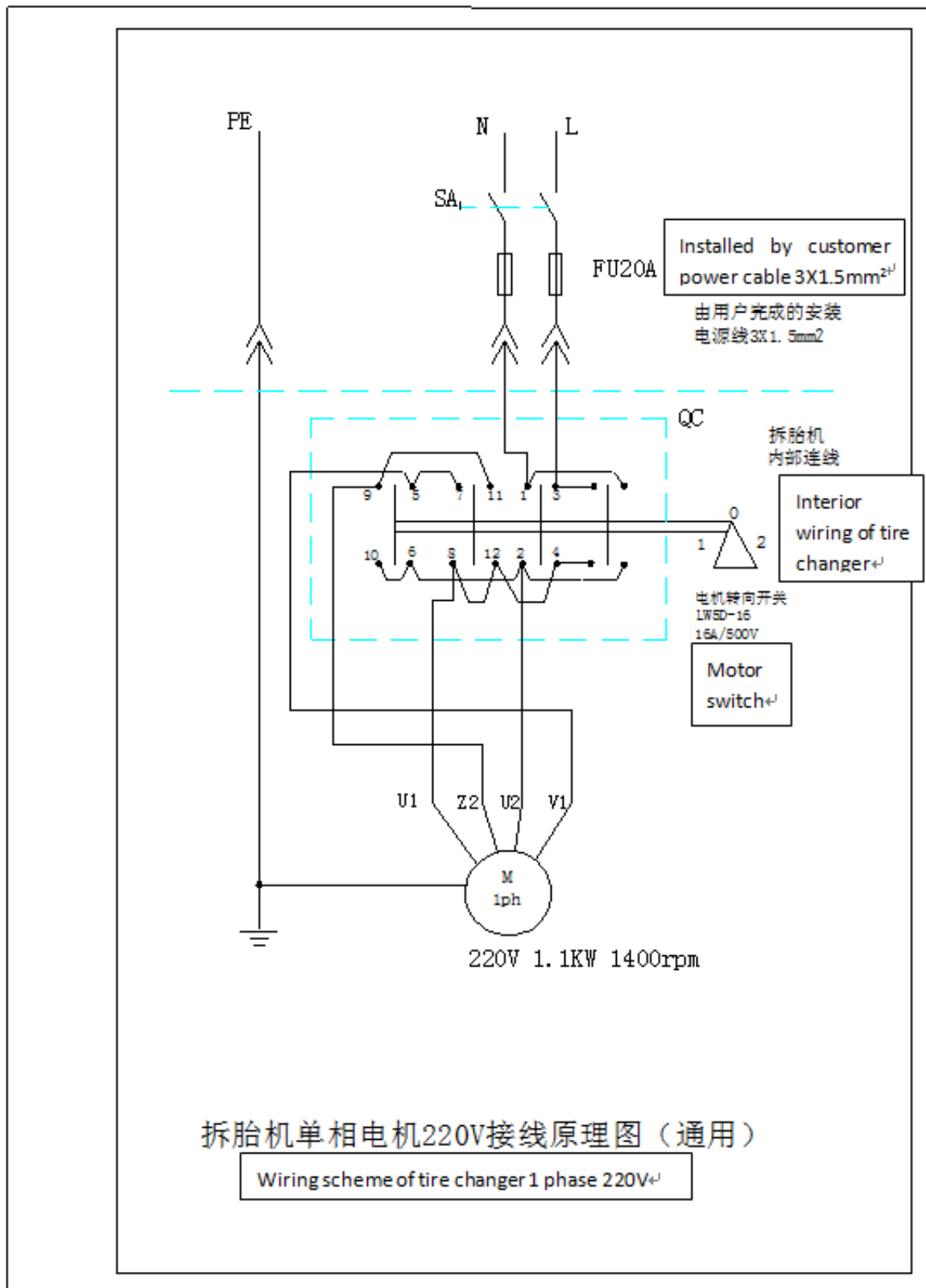

FIG42

## Chapter6 Electrical and pneumatic principle diagram

### 6.1 ELECTRICAL PRINCIPLE DRAWIN OF SINGLE-PHASE MOTOR



6.2 ELECTRICAL PRINCIPLE DRAWING OF THREE PHASE MOTOR WITH SINGLE SPEED

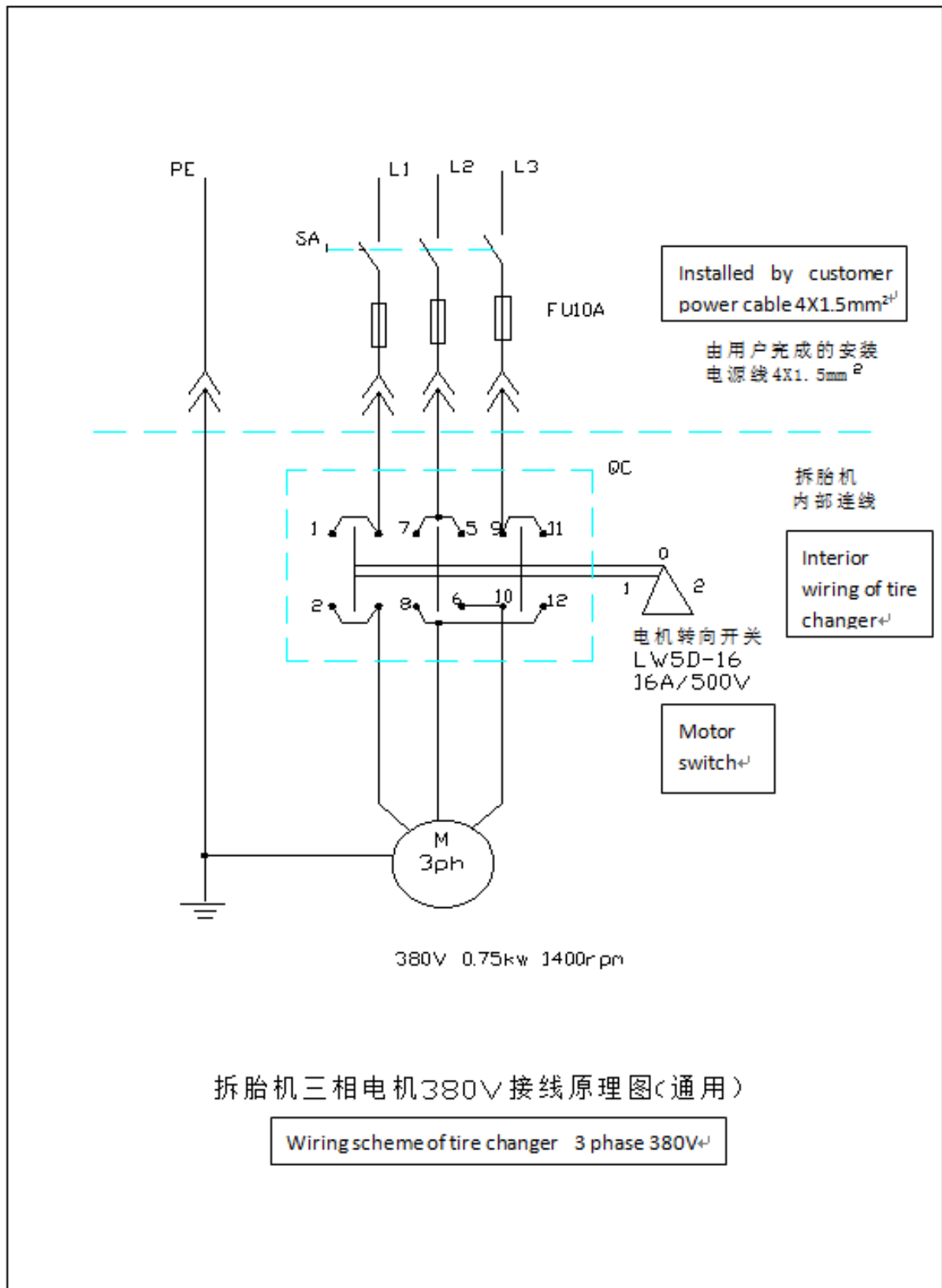

### 6.3 ELECTRICAL PRINCIPLE DRAWING OF THREE PHASE MOTOR WITH DOUBLE SPEED

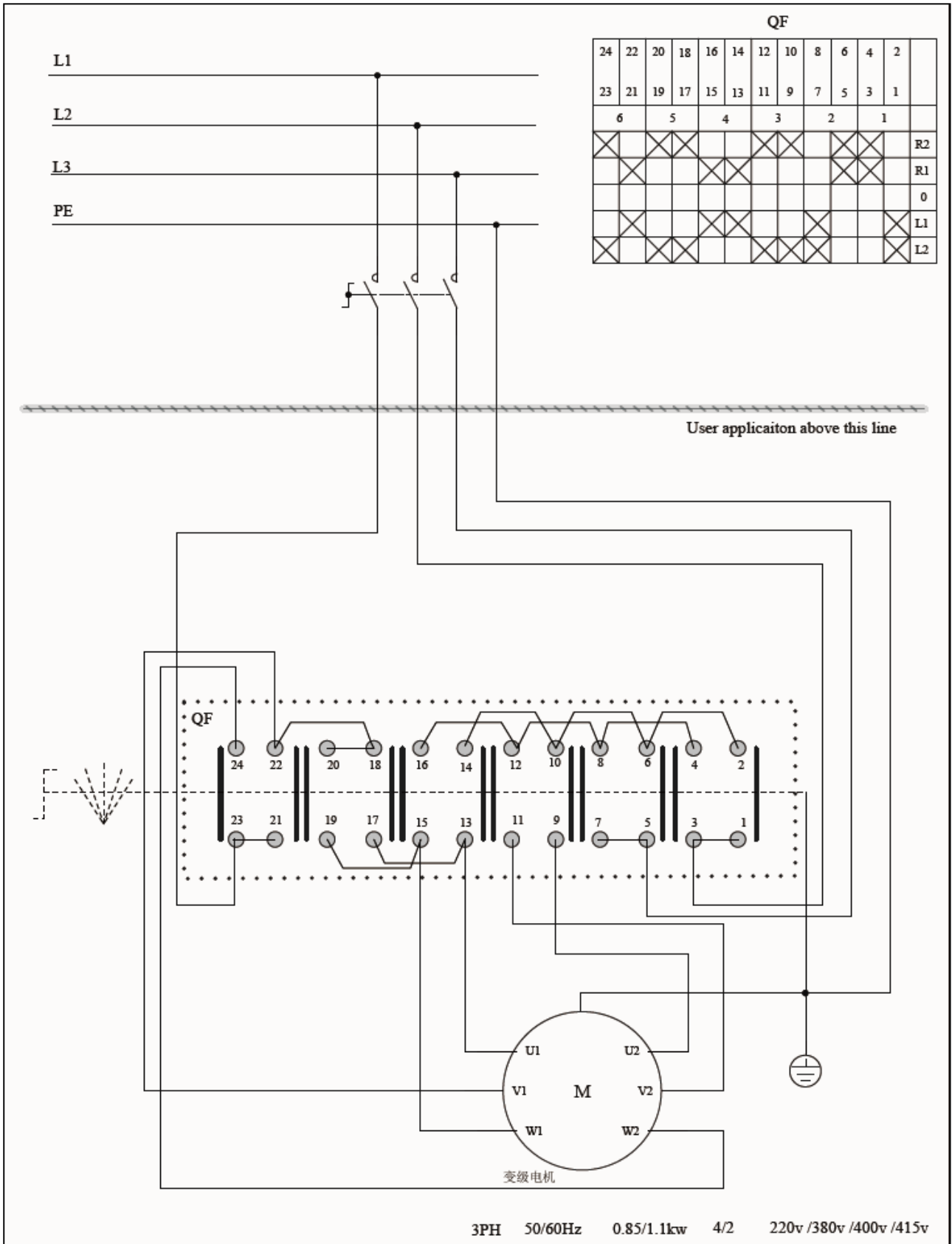

6. 4 PNEUMATIC PRINCIPLE DRAWING

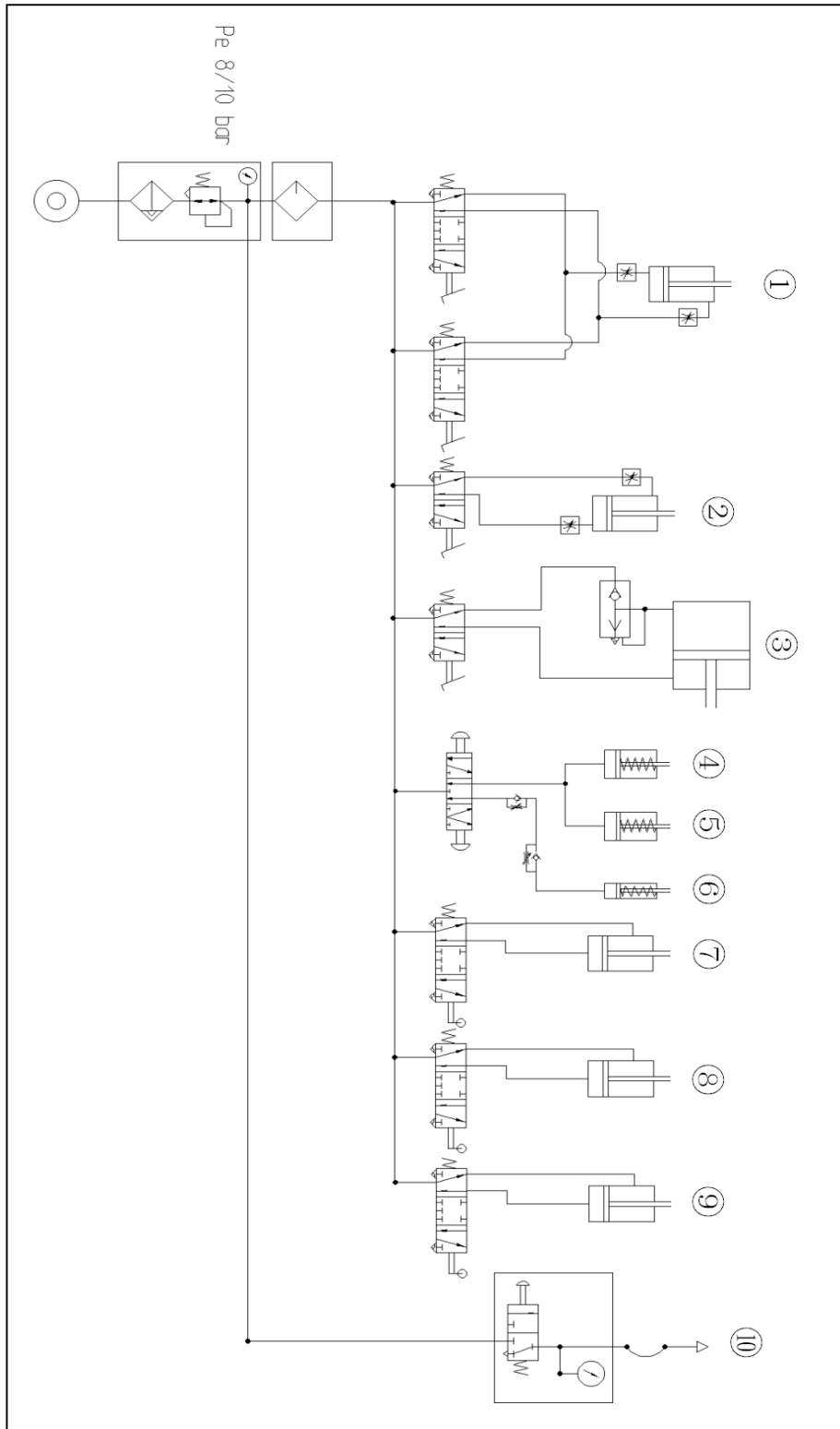

- 1.LIFTER CYLINDER 2.TILT CYLINDER 3.BEAD BREAKER CYLINDER 4.LOCKING CYLINDER OF HEX SHAFT 5. LOCKING CYLINDER OF SQUARE SHAFT 6.AIR SPRING CYLINDER 7. LIFTING CYLINDER OF DEMOUNTING HOOK 8. UPWARD MOVEMENT CONTROL CYLINDER OF ASSISTANT ARM 9. DOWNWARD MOVEMENT CONTROL CYLINDER OF ASSISTANT ARM 10. INFLATOR

## Chapter 7 common troubleshooting

TROUBLE	REASON	TROUBLESHOOTING
Turntable rotates in one direction.	Universal switch contact burned	Change Universal switch
Turntable does not rotate.	Belt damage Belt too loose Motor or power source have problems  Universal switch contact damage	Change belt Adjust the tension of the belt Check motor, power source and power source cable Change motor if motor burned Change Universal switch
Turntable cannot clamp the rim as normal	Claw worn Clamp cylinder air leakage	Change claws Change the air leakage sealing parts
Quadric and hexangular shaft cannot lock	Lock plate not in position	Refer to the chapter V
Horizontal arm moves unsmooth. Vertical hex bar moves unsmooth.	Incorrect position of square plate Incorrect position of hex plate	Refer to chapter 5 How to adjust the locking plate
Tilt arm moves too fast or too slow.	Exhaust air speed of tilt cylinder is too fast or too slow; Low air pressure.	Remove the side panel and adjust the air valve.
Chassis pedal not return.	Pedal return spring damage	Change torsion spring
Motor not rotate or the output torque not enough	Drive system jam Capacitor broken down Voltage not enough Short-circuit	Remove the jam Change capacitor Wait for the restore of the voltage Remove
Cylinder output force not enough	Air leakage Mechanic fault Air pressure not enough	Change sealing parts Remove the fault Adjust the air pressure to meet the requirement



The manufacturer is entitled to make changes to the products without prior notice to the buyer.