



# BIQU-B1

## USER MANUAL













Shenzhen Bigtree Technology Co.,Ltd

# Catalogue

1. Packing List.....	1
2. Equipment parameters.....	2
3. Installation equipment.....	3
4. Platform Calibration.....	17
4-1 Platform Calibration.....	17
4-2 Fill in filament.....	21
5. Ready to print.....	22
5-1 Introduction to working mode.....	22
5-2 Installing Driver software.....	23
5-3 Install Ultimaker Cura Software.....	27
5-4 Software Settings.....	30
5-5 Usage of Ultimaker Cura Software.....	34
6. Start Printing.....	36
6-1 Offline printing.....	36
6-2 Online Printing.....	38
7. Other Functions.....	40
7-1 Manual leveling.....	40
7-2 Automatic Leveling (Optional) .....	43
7-3 Intelligent filament detection Sensor Module (Optional).....	45
7-4 Model Preview.....	47
7-5 Marlin Operating System.....	54
8. Troubleshooting.....	56
9. Cautions.....	60

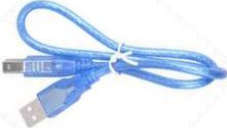
# 1. Packing List

		
	Wrench and screw bag (1set)	Diagonal pliers (1pcs)
		
BIQU-B1 (1pcs)	TF card and card reader (1set)	Nozzle (2pcs)
		
Power cable (1pcs)	Rack (1pcs)	BLtouch stand (1pcs)
		
Data cable (1pcs)	Filament for test (45g)	Cable tie (5pcs)

## 2. Equipment parameters

<b>The basic parameters</b>	
Printer Name	BIQU-B1
Printing Size	235 x 235 x 270mm
Molding Tech	FDM
Nozzle Quantity	1 PCS
Layer Thickness	0.1mm - 0.3mm
Nozzle Diameter	Standard 0.4mm
Printing Accuracy	±0.05mm
Filament	PLA
Slicing Format	STL / OBJ/ AMF
Connecting Method	Via data cable / TF card / USB
Slicing Compatible	With Cura / Repetier-Host / Simplify 3D
Rated Voltage	100 - 120V / 200 - 240V 50 / 60 HZ
Output Voltage	24V
Rated Power	270W
Max Temp of Hot Bed	100°C
Max Temp of Nozzle	260°C
OS compatible	with Win 7 / Win 10
Maxium operating speed	180mm/s
Max Printing Speed	100mm/s
Normal Printing Speed	60mm/s
Language Transform	Supported
Resume Printing	With resume printing function
Filament Run Out Detection	With filament run out detection function

### 3. Installation equipment

#### Step 1

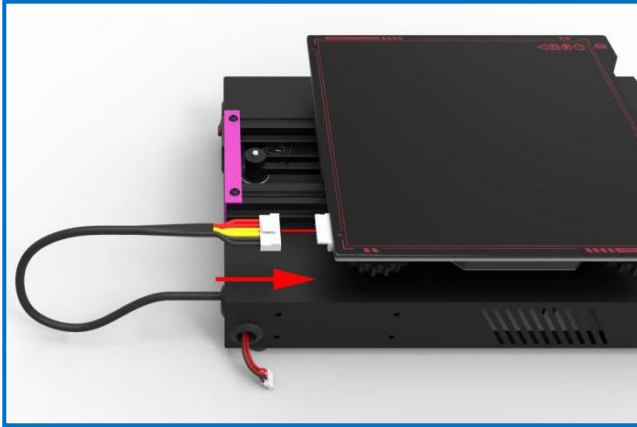

Connecting the terminal wire to the socket of the hot bed.

#### Step 2



There are two M5 threaded holes on the end of the 2040 aluminum profile, which is used for mounting the M5×16 hex socket head screws.

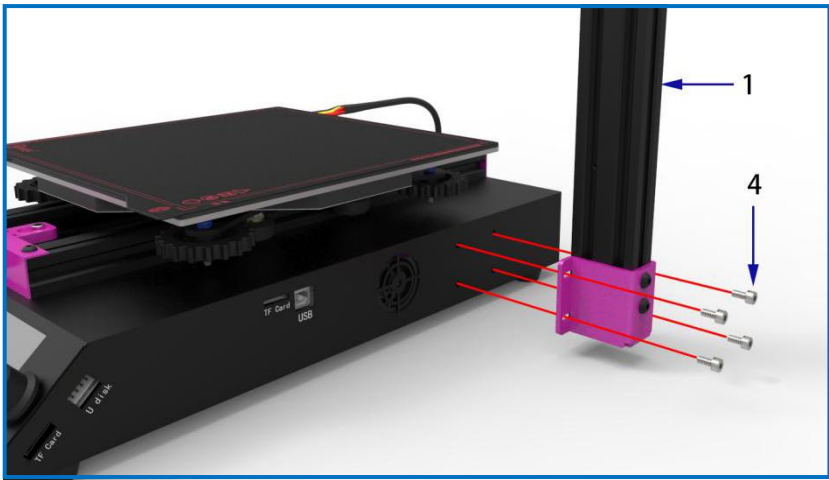
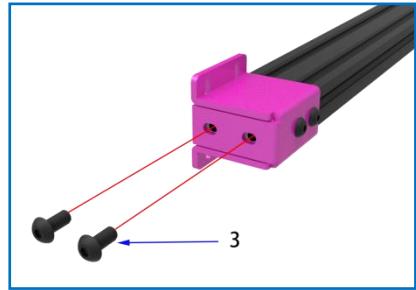
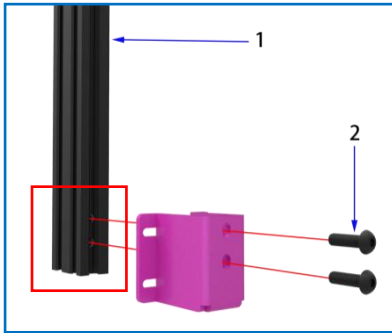

1. 2040 aluminum profile—length 456mm (1pcs)
2. M5×16 hexagon round-head screws (2pcs)
3. M5×10 hexagon round-head screws (2pcs)
4. M4×8 hexagon cup-head screws (4pcs)

### Step 3

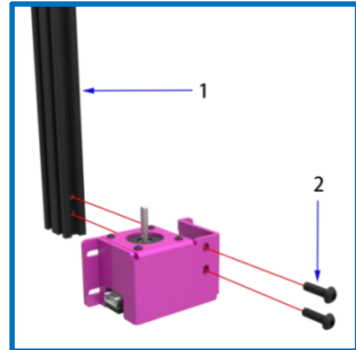
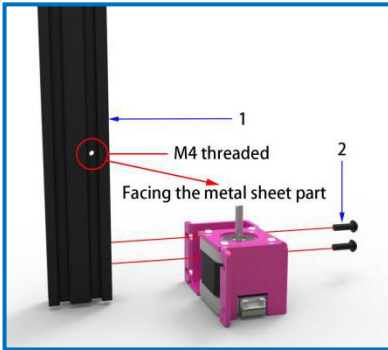

There is a M4 threaded holes on another 2040 aluminum profile. When installation, users make the threaded hole face the metal sheet part.

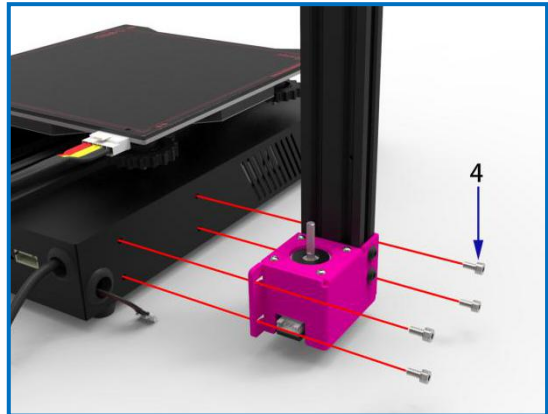
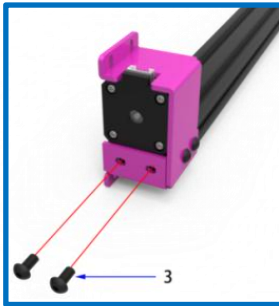

1. 2040 aluminum profile--length 456mm (1pcs)
2. M5 × 16 hexagon round-head screws (2pcs)
3. M5 × 10 hexagon round-head screws (2pcs)
4. M4 × 8 hexagon cup-head screws (4pcs)

## Step 4

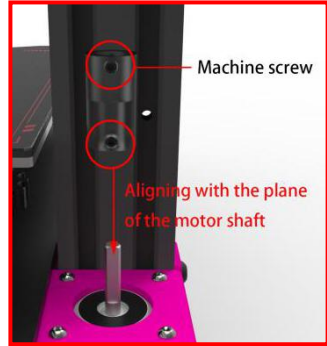
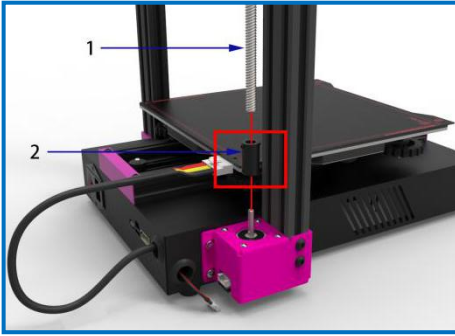

1. T8 screw (1pcs)
2. Coupling device (1pcs)

There are machine screws inside the coupling device, which is used to tighten the motor shaft and screw rod. The set screw is aligned with the plane of the motor shaft when installing.

## Step 5

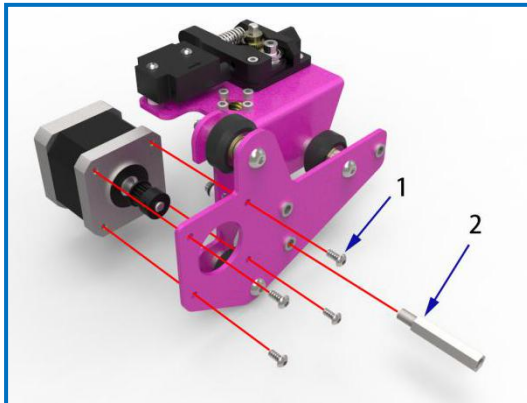

1. M3 × 6 hexagon round-head screws (4pcs)
2. Hexagonal isolation column (1pcs)



Step 6

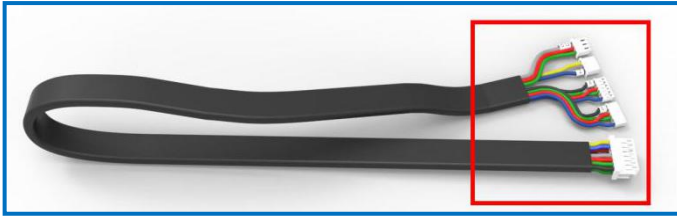

4 in 1 terminal wire

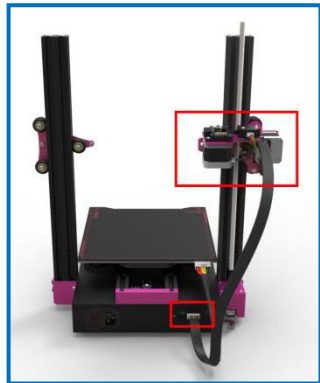
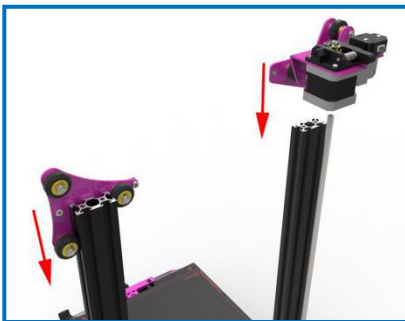
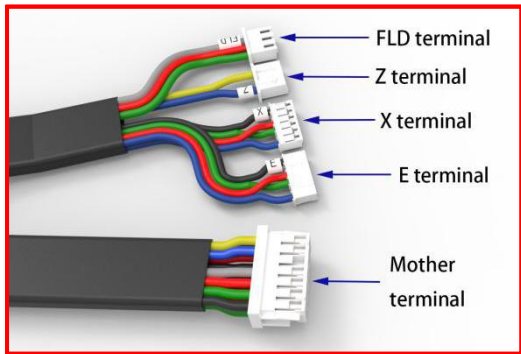

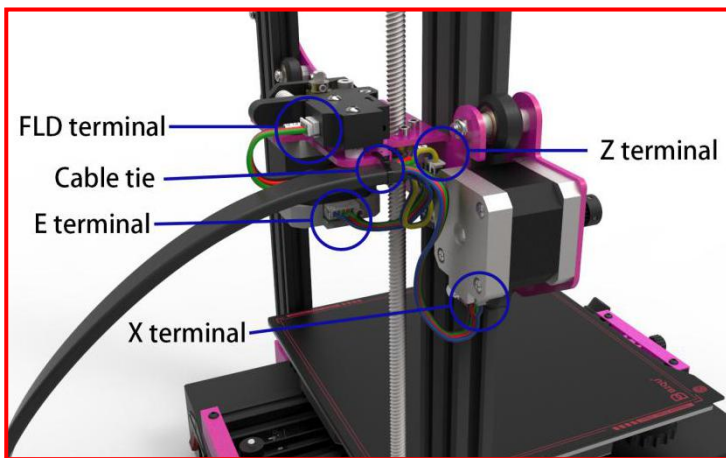

As shown above, installing the 4 in 1 terminal wire to its corresponding position. Then there are two key slots on the metal sheet part. Users can use a cable tie to fix the terminal wire through them.

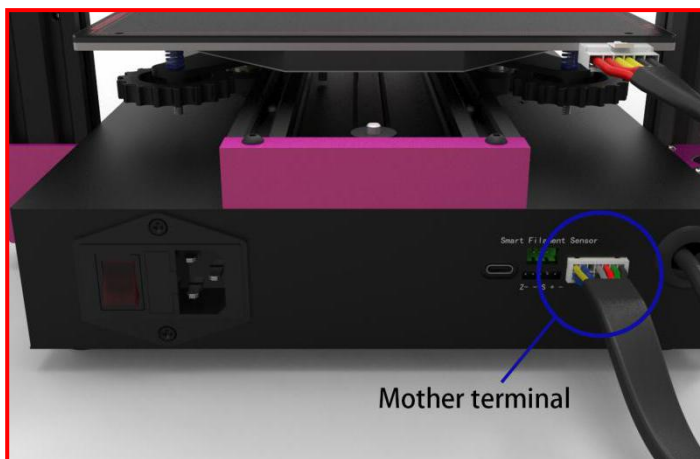

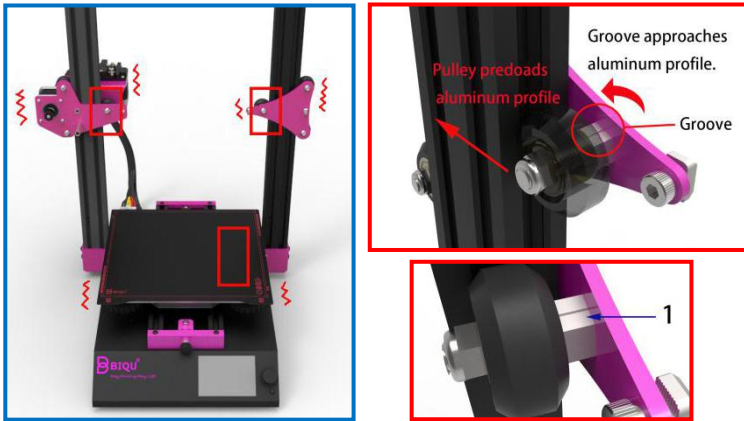

## 1. Eccentric nut

**Awareness:** As the picture, please check whether the interfaces are loose. If they are loose, please tight the eccentric nut with wrench and make the groove of eccentric nut approach the aluminum profile. Pulley on eccentric nut will preload aluminum profile. The printer will be more stable by this way.

## Step 7

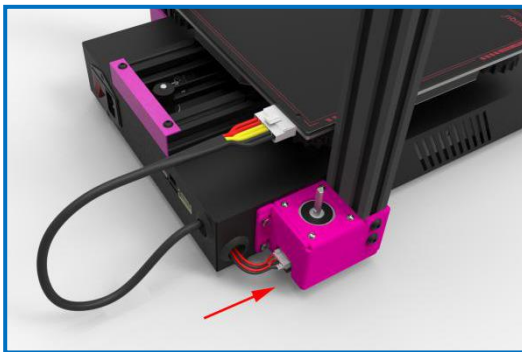

Connecting the terminal wire on side to the motor's port.

## Step 8

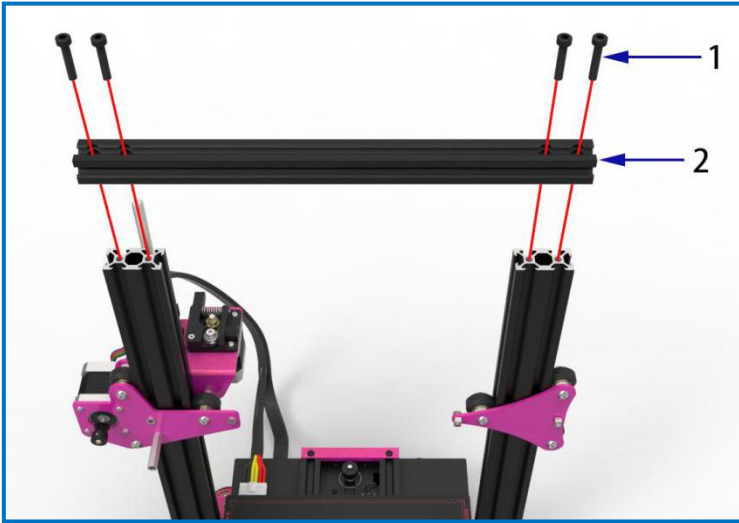

1. M5×25 hexagon cup-head screws (4pcs)
2. 2020 aluminum profile—length 323mm (1pcs)

## Step 9

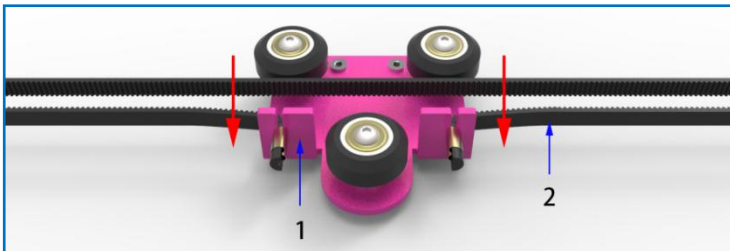

1. X slider sheet (1pcs)
2. Belt (1pcs)

## Step 10

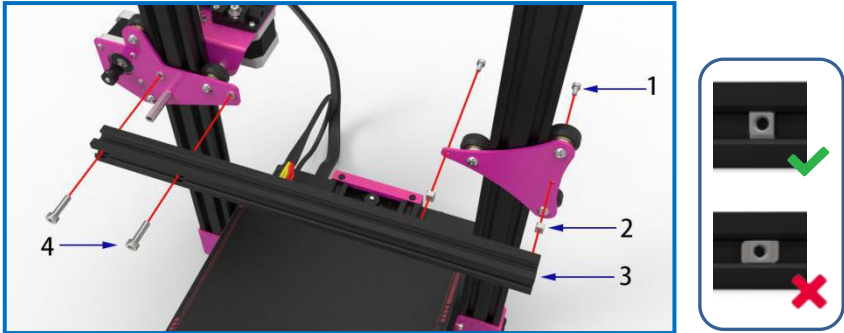

1. M4×8 hexagon cup-head screws (2pcs)
2. M4 boat-shape nut (2pcs)
3. 2020 aluminum profile—length 338mm (1pcs)
4. M5×18 hexagon cup-head screws (2pcs)

The boat-shape nut may rotate during installation. Users could use the screws to fix it on the aluminum profile.

## Step 11

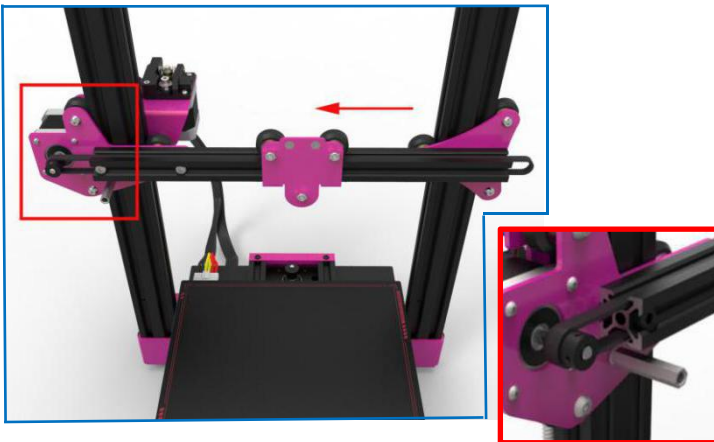

Installing the belt onto the 2020 aluminum profile.

## Step 12

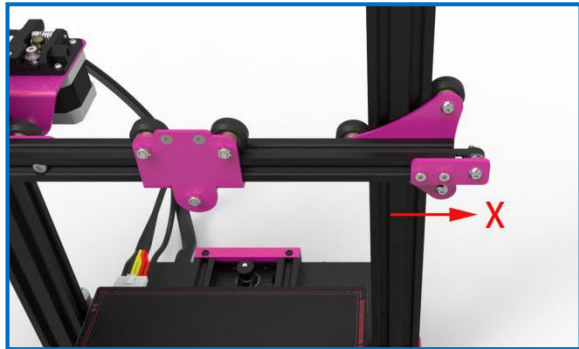
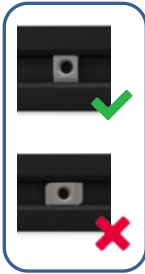
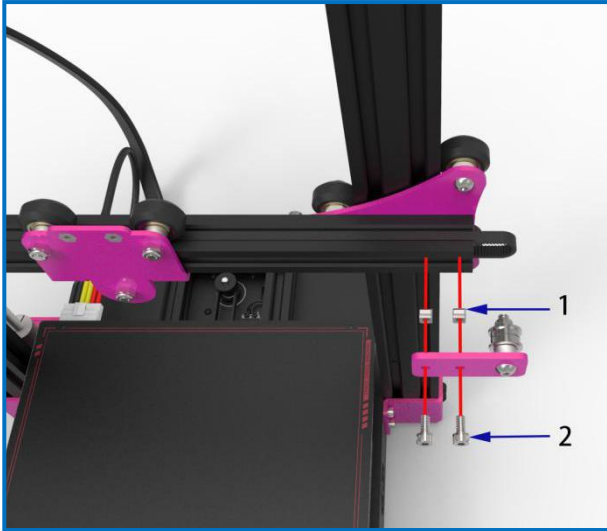

1. M4 boat-shape nut (2pcs)
2. M4×8 hexagon cup-head screws (2pcs)

Notice: The boat-shape nut may rotate during installation. Users could use the screws to fix it on the aluminum profile.

When installation, in order to tighten the pulley and the belt, users could push the parts slowly in the X direction.

### Step 13

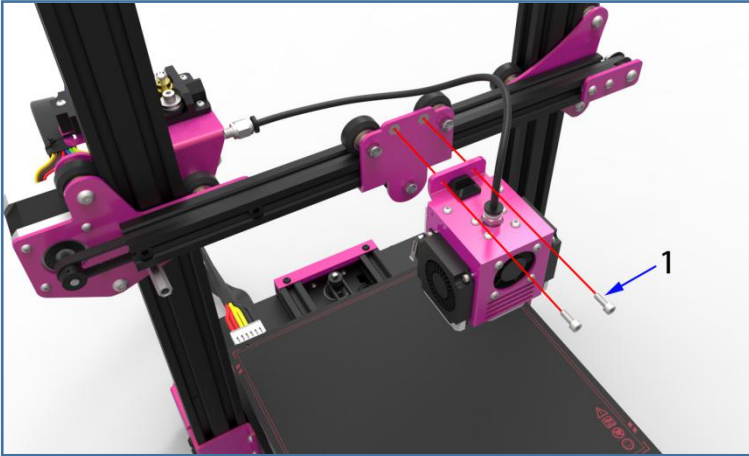

1. M3×8 hexagon cup-head screws ( 2pcs )

### Step 14

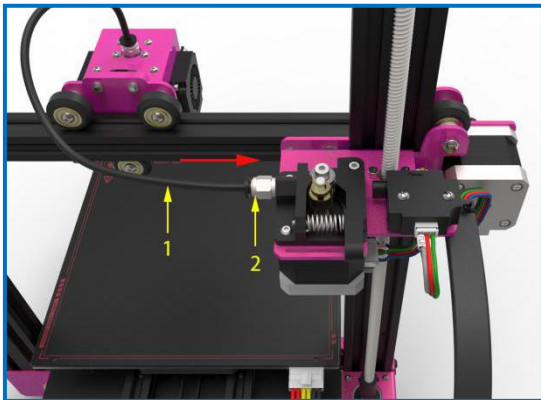

1. Feed tube ( 1pcs )
2. Quick connector ( 2pcs )

## Step 15

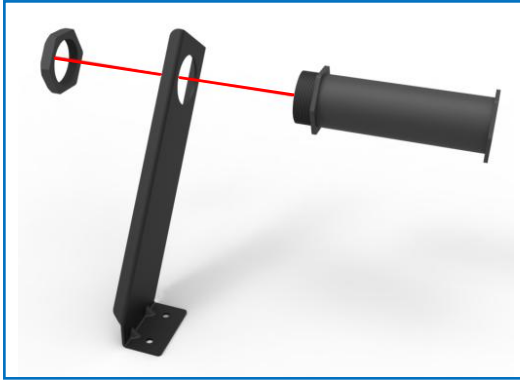

## Step 16

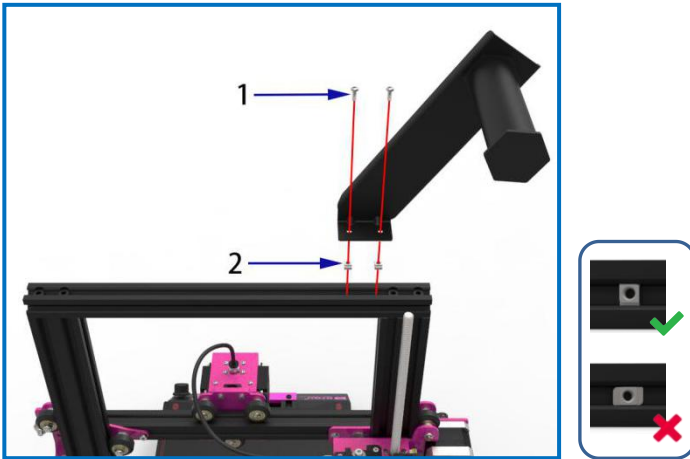

1. M4×8 hexagon round-head screws (2pcs)
2. M4 boat-shape nut (2pcs)

The boat-shape nut may rotate during installation. Users could use the screws to fix it on the aluminum profile.



## Step 17

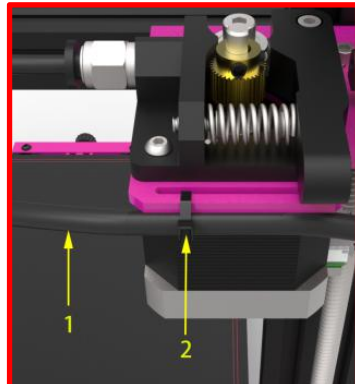
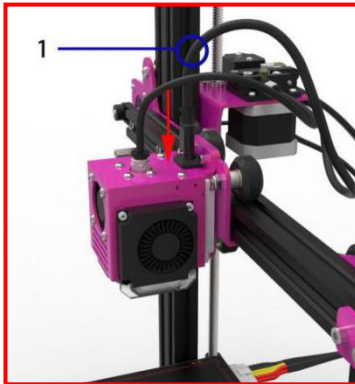
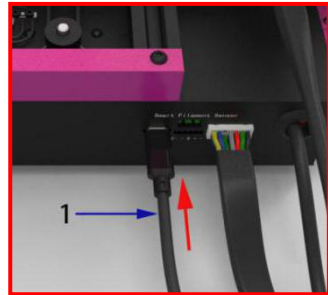
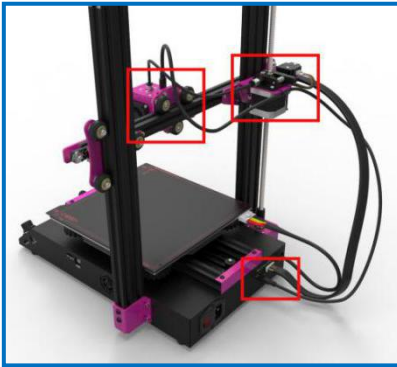

1. Type-C data cable (1pcs)

2. Cable tie (1pcs)

As shown above, there are two key slots on the metal sheet part. Users can use a cable tie to fix the Type-C cable through them. But before fixing the data cable, users would better leave a certain length at the Type-C cable's end which closes to the nozzle. It facilitates the movement of the nozzle.

**Awareness:**

1.do not unplug the Type-C data cable when the machine is on.

2.The Type-C cable is customized, it can not be replaced by others.

## Step 18

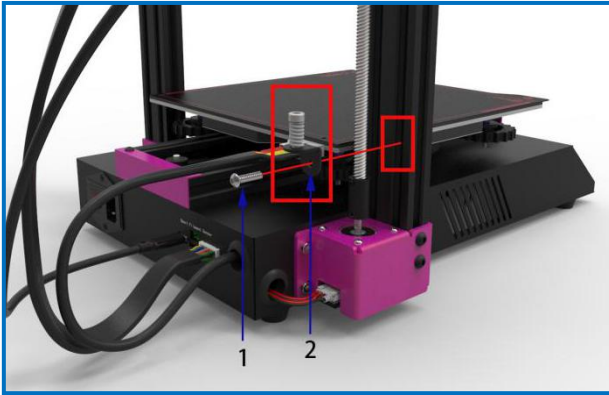

1. M4×16 hexagon round-head screws (1pcs)
2. Z axis limit module

Fixing the Z-axis limit module on the aluminum profile by using the M4 threaded holes and the above screws.

**Awareness:** Please check all the screws and make sure that they are properly installed.

# Installation Finished !

## 4. Platform Calibration

### 4-1 Platform Calibration

After the installation of BIQU B1, users need to perform a platform calibration on BIQU B1. The steps are as follows:

#### Step 1



1. Power switch
2. Power cord socket

**Awareness:** Before turning on, please check whether the voltage mode matches your household power supply. If not, you can select the mode by using screwdriver.

Confirming that the wiring is steady and correct. Inserting one end of the power cord into the power cord socket and the other end into the household power supply, and then turn on the power switch of the machine.

**Awareness:** do not unplug the Type-C data cable when the machine is on.

# Step 2

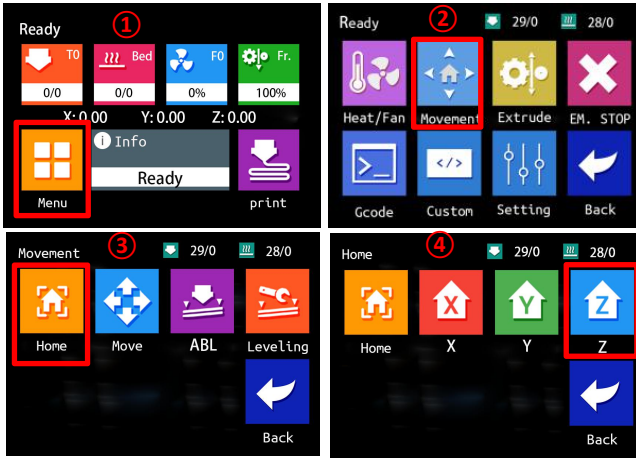

Clicking on the touch screen homepage① “ Menu ” → ② “ Movement ” → ③ “ Home ” → ④ “ Z ” 。

The nozzle moves back to the zero point of the Z axis, which is above the platform. Twist the 4 hand-tight nuts counterclockwise under the hot bed so that there is a distance of 3 ~ 6mm between the hot bed and the nozzle.

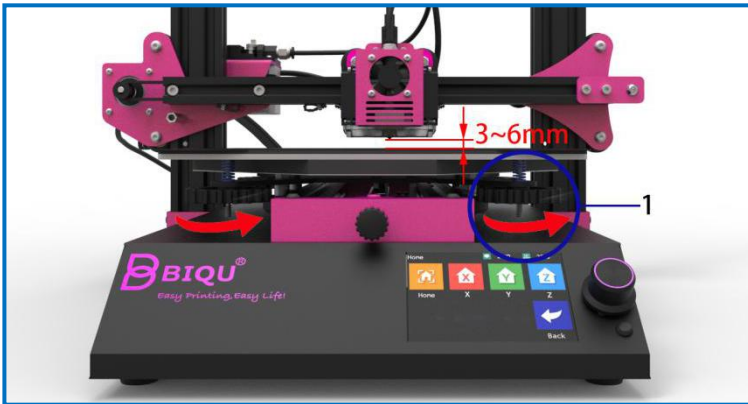

- 1. Hand-screw nut (4pcs)

## Step 3

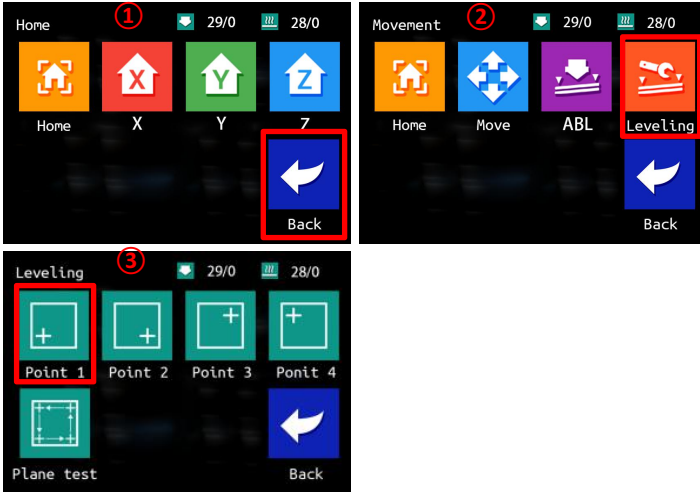

Select from the touch screen in the previous step ① “Back” → ② “Leveling” → ③ “Point 1” .

When the nozzle moves to the "first point" position(as shown below ), and user put a piece of A4 paper under the nozzle. Twisting the hand screw nut to make the nozzle just contact with the A4 paper and that the A4 paper can move smoothly with slight friction.

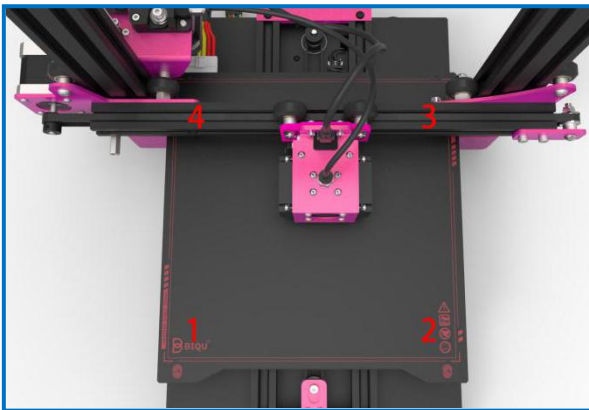

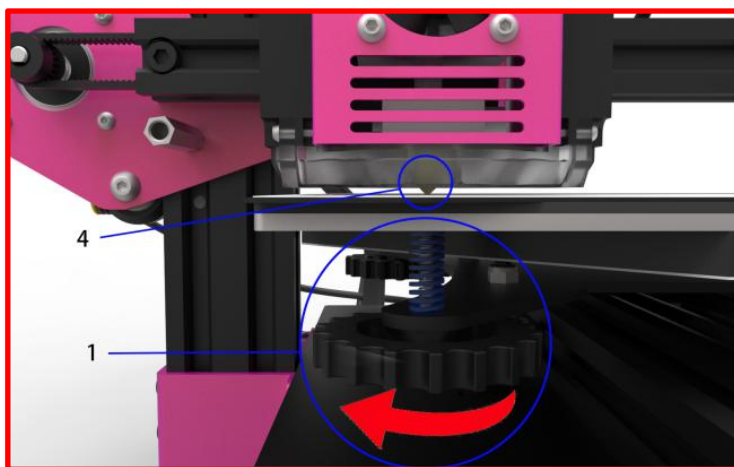
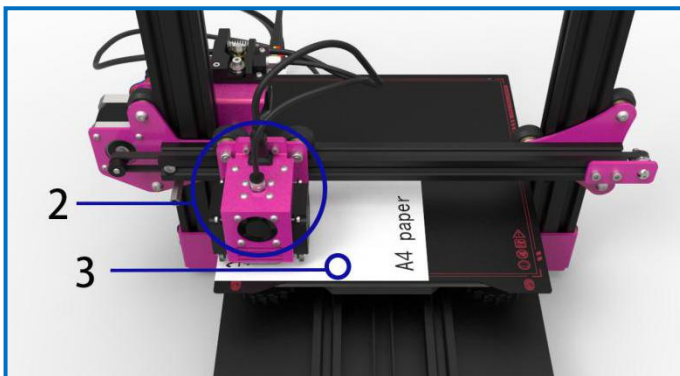

- |                            |                      |
|----------------------------|----------------------|
| 1. Hand-screw nut ( 4pcs ) | 3. A4 paper ( 1pcs ) |
| 2. Nozzle-head ( 1pcs )    | 4. Nozzle ( 1pcs )   |

When users turn the hand-screw nut clockwise, the platform will rise, and when users turn the nut clockwise, the platform will fall.

In the same way, touch the "second point", "third point" and "fourth point" on the screen in turn, and use the same method to turn the hand-screw nut under the platform to manually level the platform.

## 4-2 Fill in filament

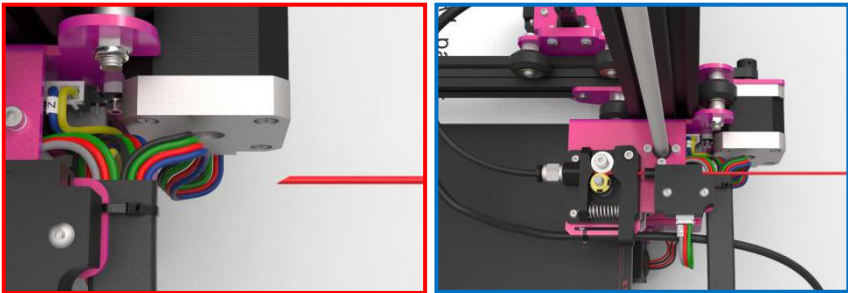
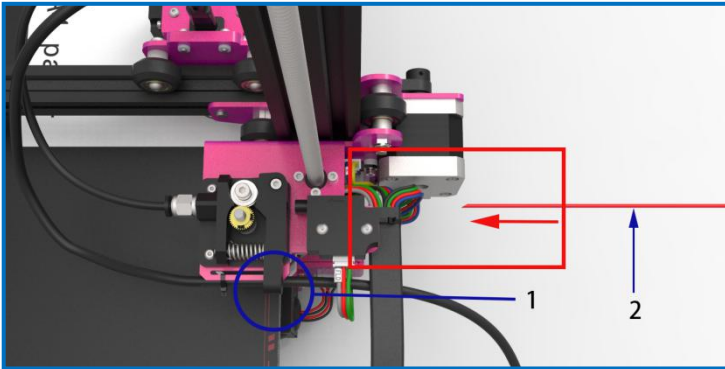

1. Extruder handle
2. Filament

Cut a bevel on filament with Diagonal pliers, Holding the handle of the extruder while users pushing the filament into the extruder into the feed tube.

**Awareness:** Please check all the screws and make sure that they are properly installed.

## Calibration Finished

# 5. Ready to print

## 5-1 Introduction to working mode

BIQU-B1 3D printer has two working modes, offline printing mode and online printing mode.

**Offline printing :** After adjusting the platform, save the slice file generated by the slicing software in the TF card, then insert the TF card into the TF card slot of the base, click "Print" from the main interface, and then select the file in the TF card to print.

**Online printing :** Connected the computer with the 3D printer through a data cable, using slicing software (such as Ultimaker Cura) to control the printer. However, printing signal transmitted through the data line may cause unstable factors such as signal interference. **Therefore, it is recommended that the customer use offline printing if possible.**

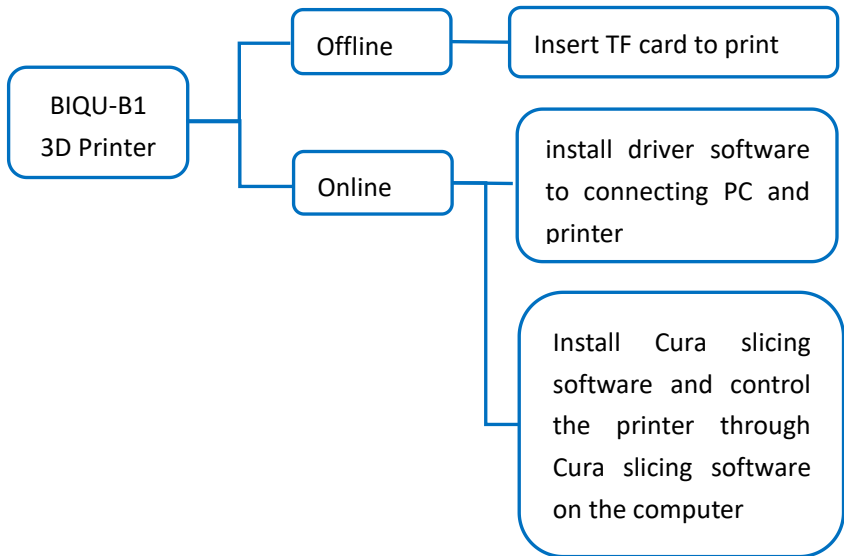



## 5-2 Installing Driver software

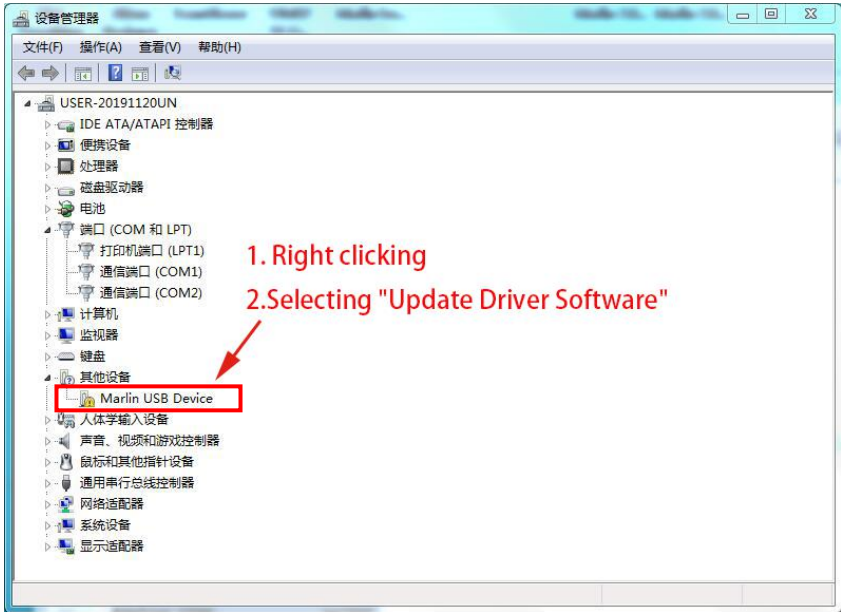

Turn on the power of the 3D printer, and connect the computer to the 3D printer through the data cable. Right-click "This Computer" → "Properties" → "Device Manager", and then the window will show above. If there is a yellow exclamation mark or question mark shown in the box, users need to manually install the driver. If not, it means that the driver has been installed automatically, no need to perform the following driver installation steps.

Then follow the prompts shown above to install the driver software.





If the computer contains a firewall or anti-virus software, please manually agree to install the driver.

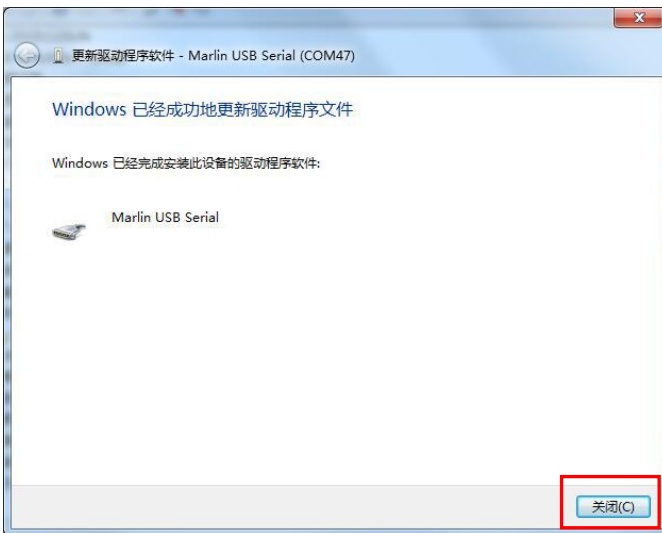

Close

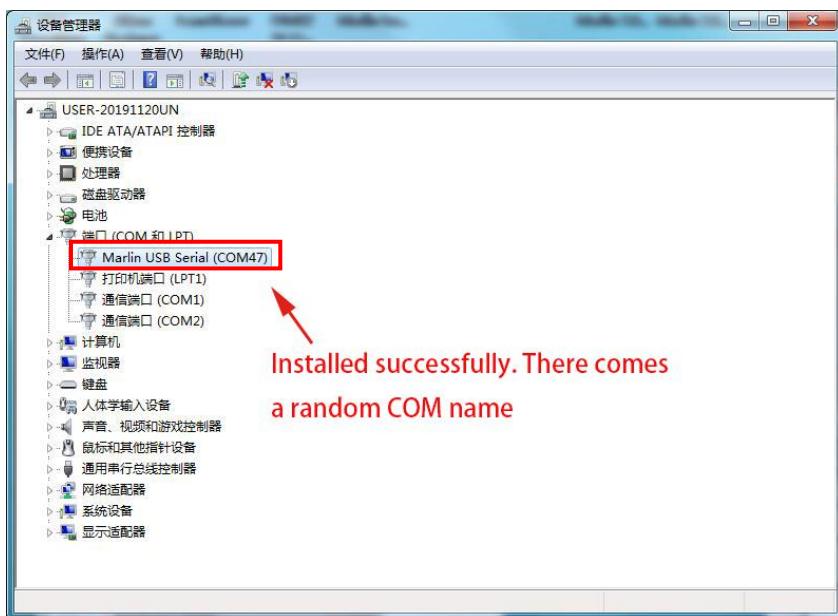

After successfully installation, you can see a random port named "Marlin USB Serial (com47)". 47 is a random number. Different numbers may appear according to different PC types. (If it is the same computer and the same printer, the port number will remain unchanged.) This port will be used for data communication between the printer and the computer.

Ps: Because the user's computer environment is different, after the driver installation is complete, if there is an exclamation mark under the "port", it means that the installation has encountered problems. At this time, please unload this port and then install the driver again.

## 5-3 Install Ultimaker Cura Software

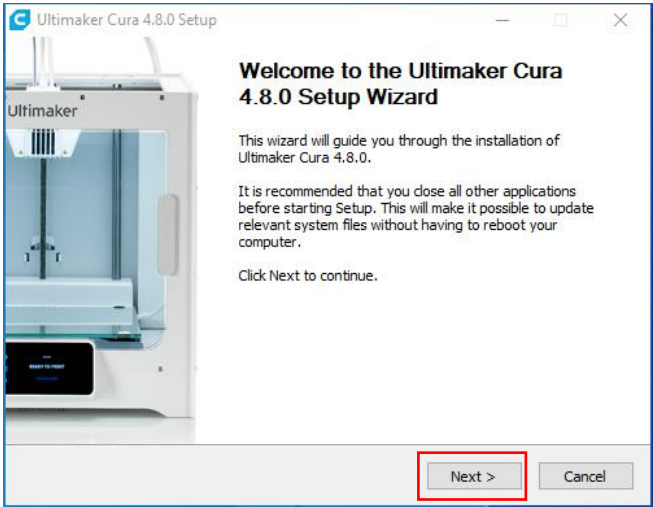

Double click the "Ultimaker.Cura-4.8.0-win64-beta.exe" application file, the software installation window will show above, please follow the below illustration to install the software.

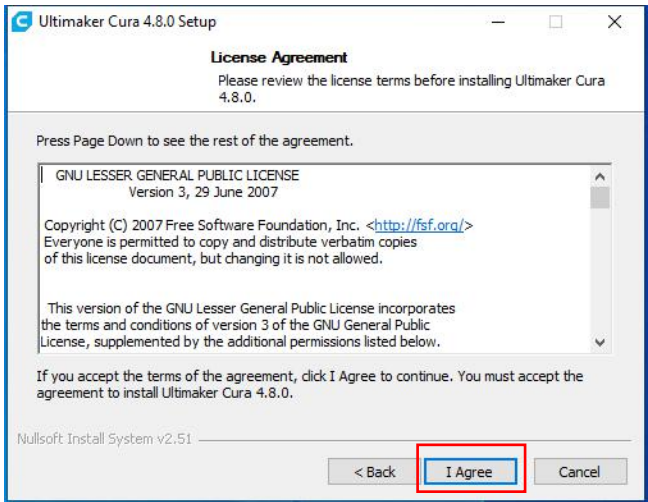

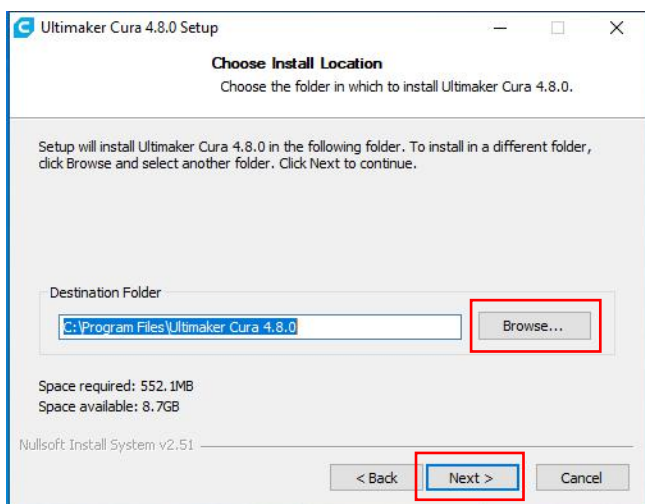

Select the location of the file installed.

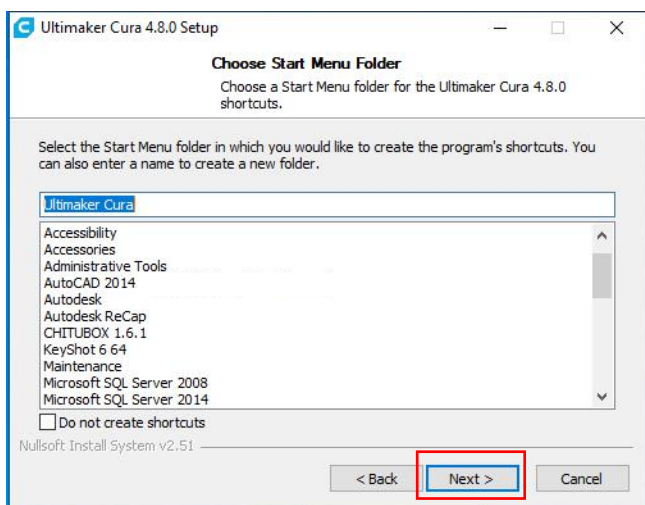

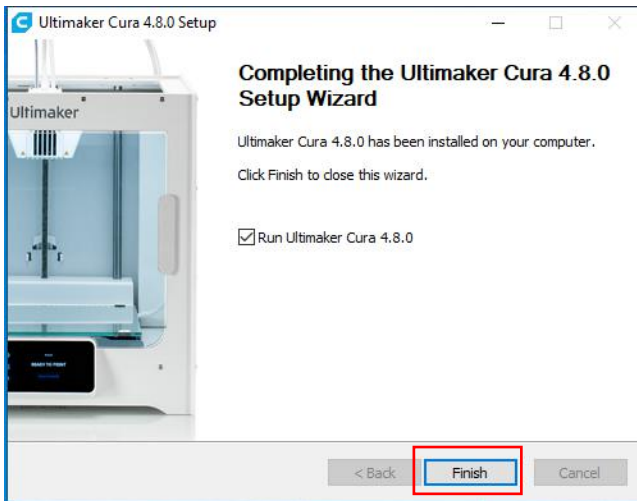
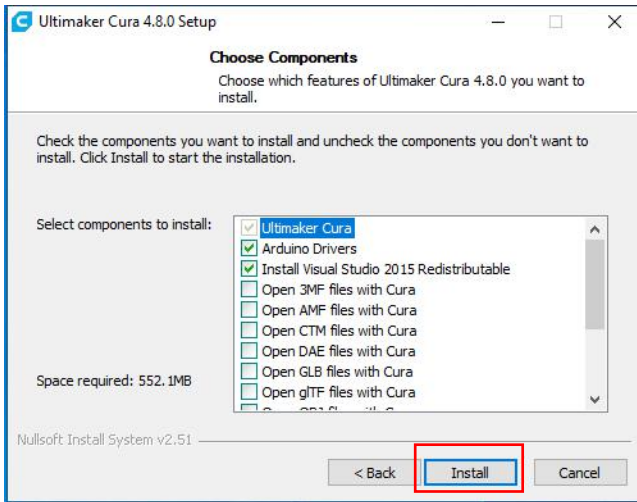

**Ultimaker Cura Installation Completed!**

## 5-4 Software Settings

After the installation, if users open the software for the first time, please set the software according to the following steps.

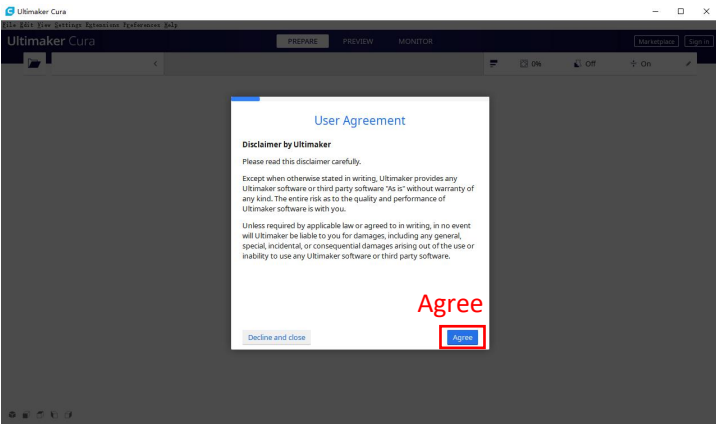
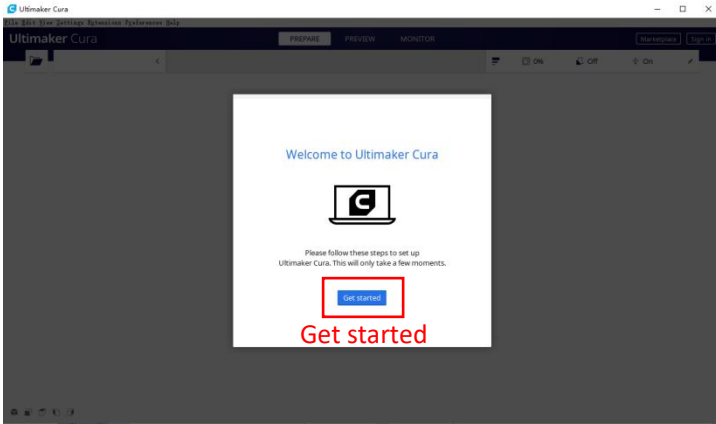



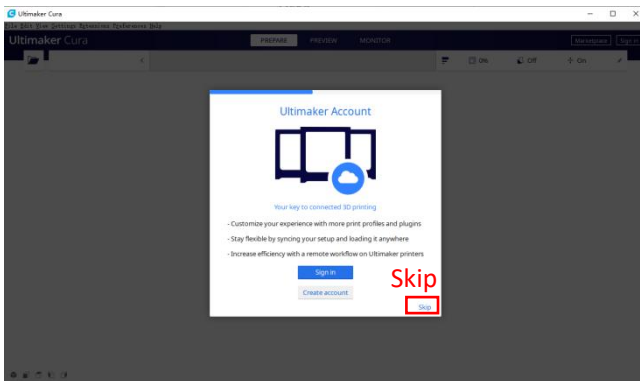
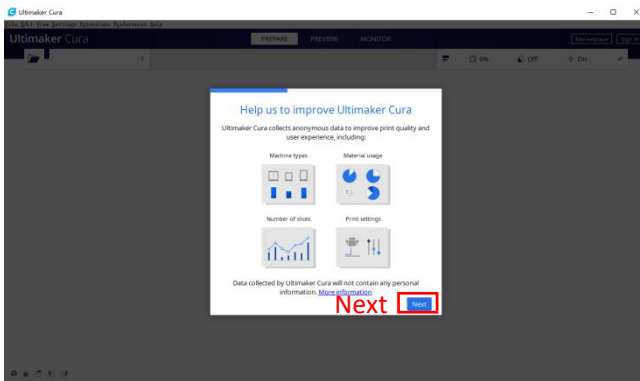
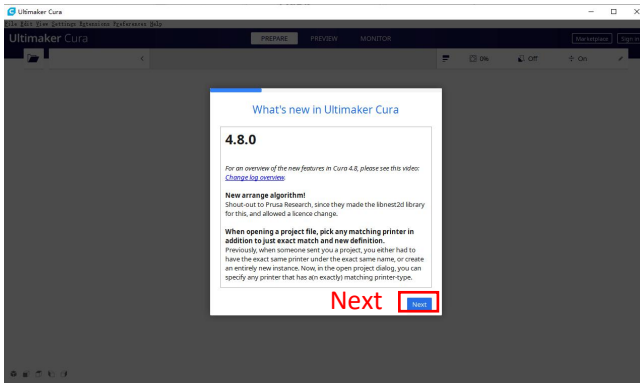

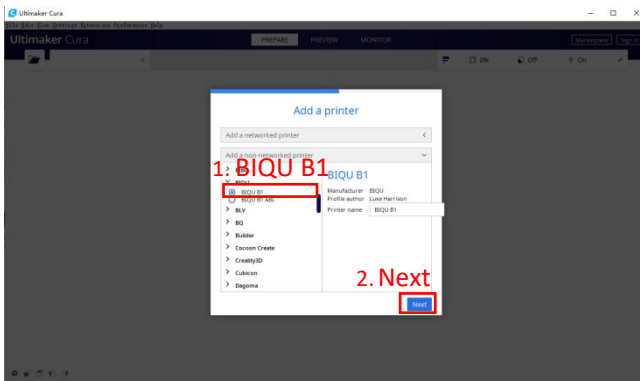
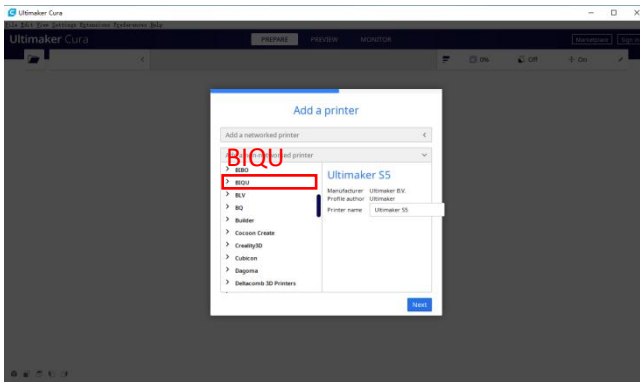
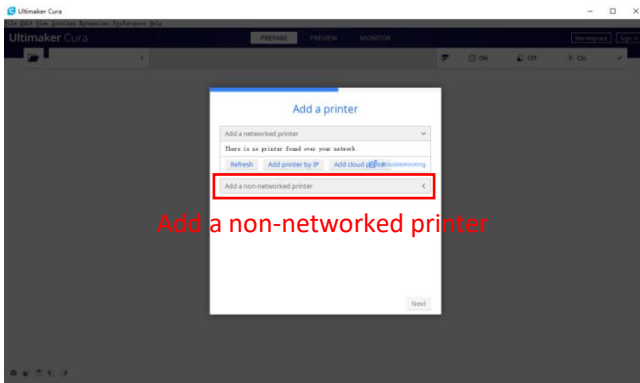

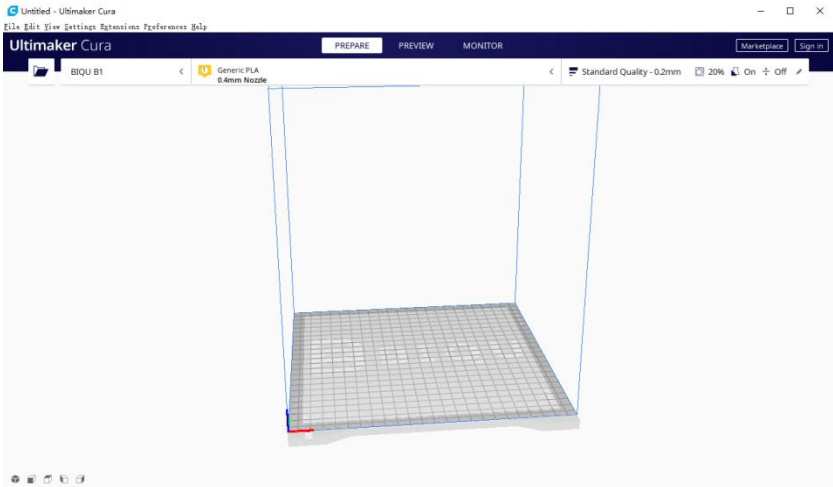
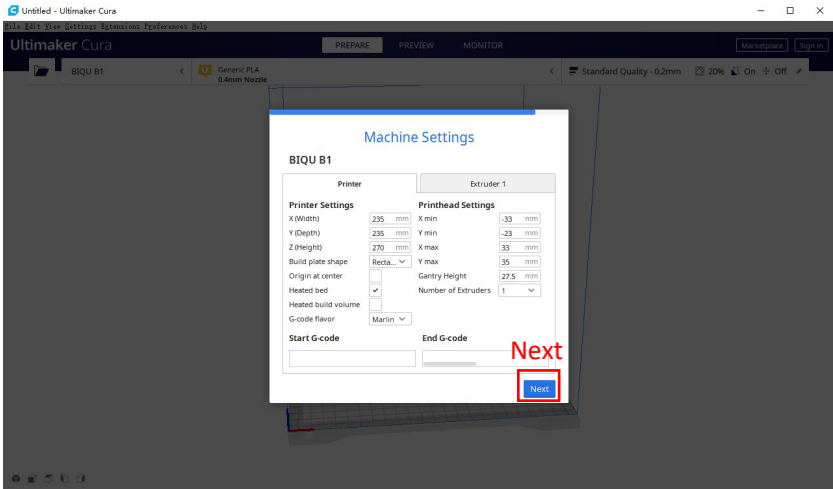

**Software Setup Completed!**

## 5-5 Usage of Ultimaker Cura Software

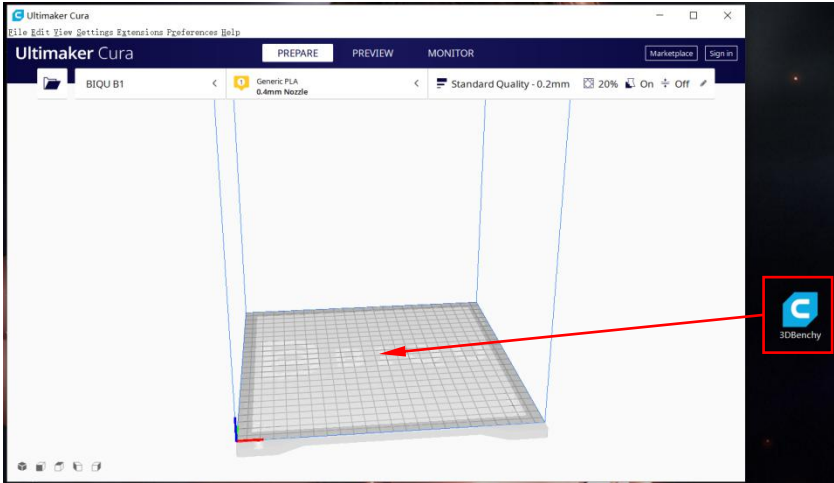

Drag the model file of stl format into the slicing software window.

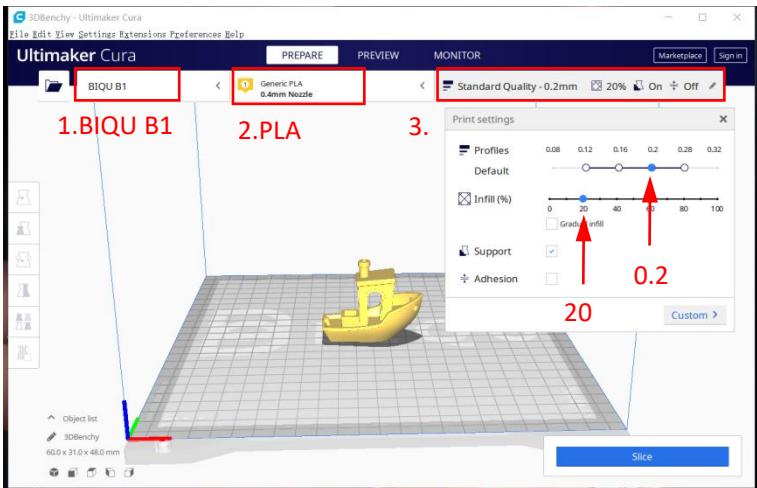

Select the printer model that users has previously set and select the slice parameters.

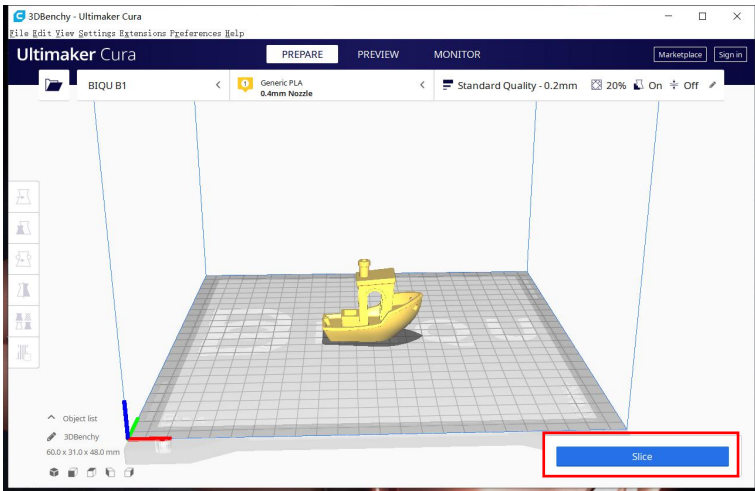

The slicing software starts slicing the model.

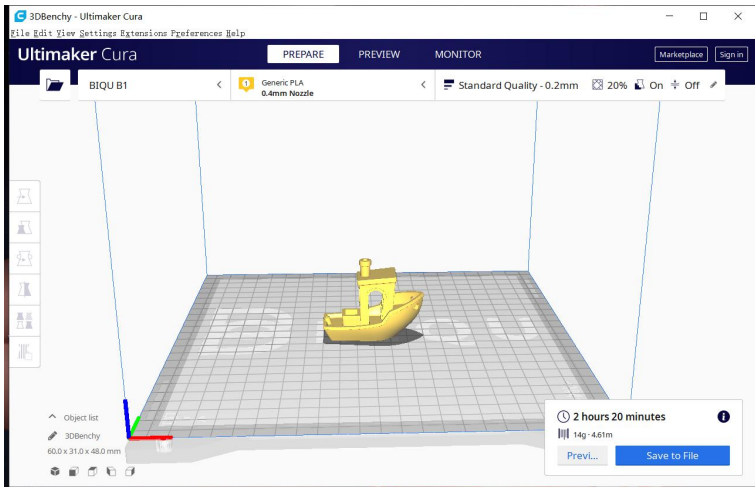

**Slice Completed!**

# 6. Start Printing

## 6-1 Offline printing

**Step 1** After the slicing software finishes slicing the model, users can start printing. First save the G-code file to the TF card after model slicing, and then use the SD card for offline printing.

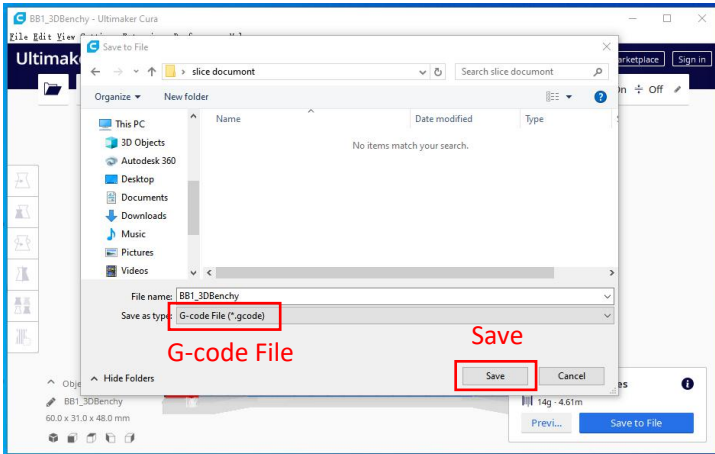
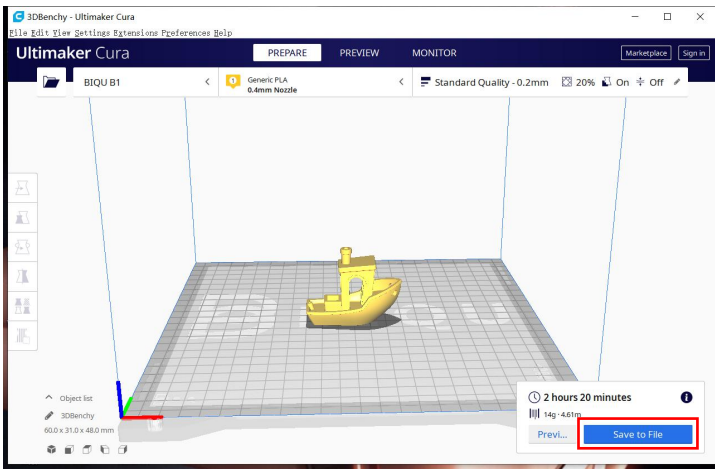

## Step 2



Put the G-code file from TF card in the card slot. (As shown in the figure)

## Step 3

Connect the power cord, turn on the machine, and select on the touch screen homepage ① “print” → ② “TFT SD” → ③ “models”, Then select the slice file saved in the TF card. The printer nozzle and hot bed start to heat. After warming to the target temperature, the machine will automatically reset to zero and then start printing.

After printing is completed, the print head and hot bed will automatically cool down. When the temperature of nozzle and hot bed reach indoor temperature, users then can remove the model.

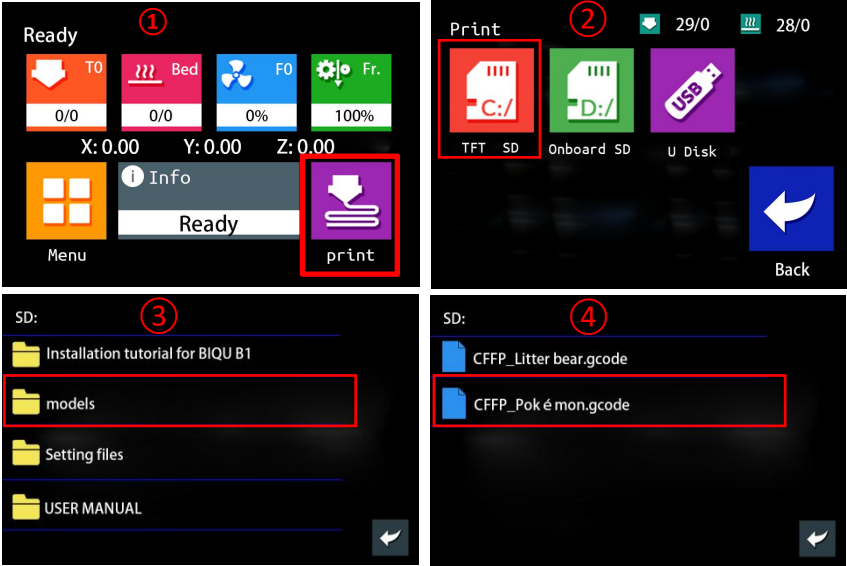

## 6-2 Online Printing

### Step 1

The computer is connected to the 3D printer via a data cable. Insert one end of the data cable into the USB port (as is shown below), and the other end into the USB port of the computer.





## Step 2

Open the slicing software. Drag the stl format model into the slicing software window to slice the model.

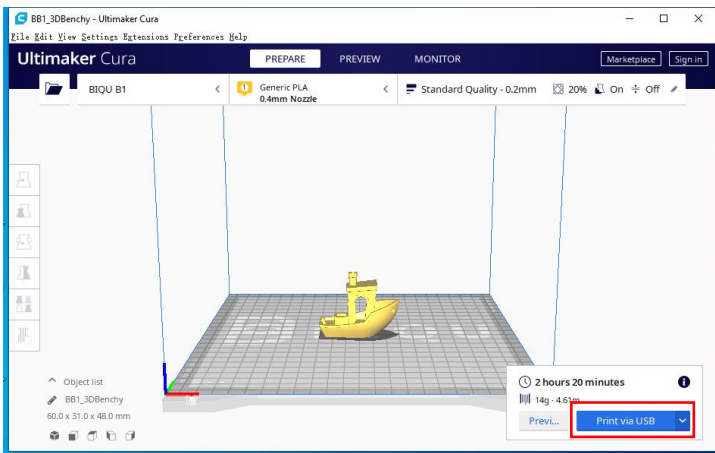
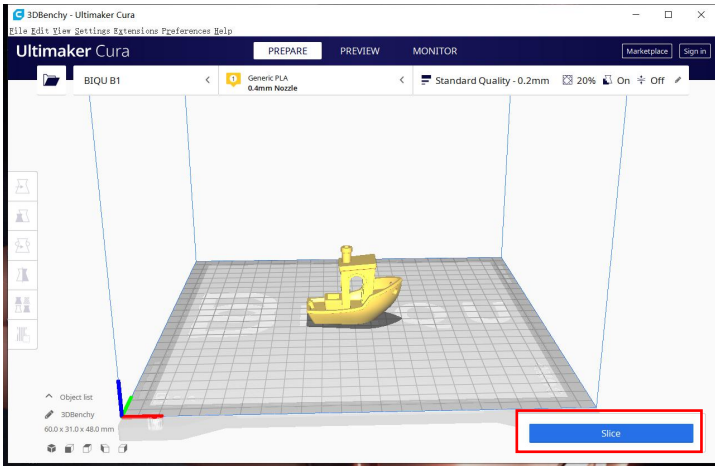

After slicing, click "Print via USB" to start online printing.

# 7. Other Functions

## 7-1 Manual leveling

**Step 1** Choose from the touch screen homepage ① “Menu” → ② “Movement” → ③ “Leveling” → ④ “Point 1”。

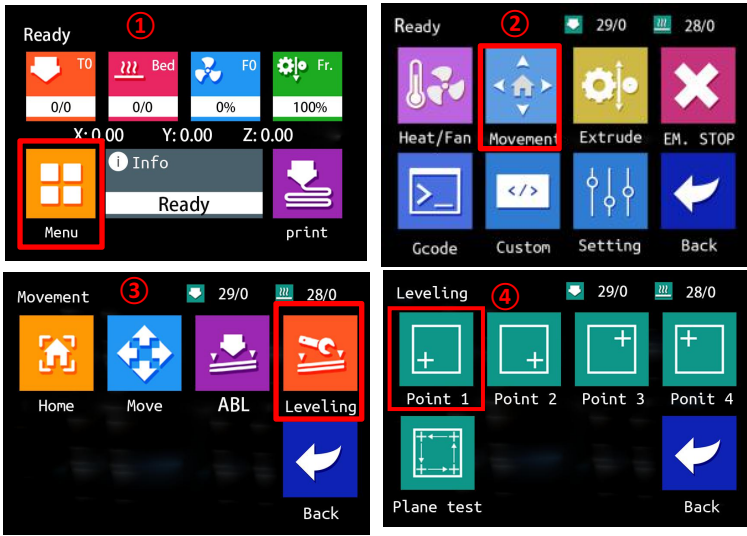

**Step 2** When the nozzle moves to the "first point" position(as shown below ), and user put a piece of A4 paper under the nozzle. Twisting the hand screw nut to make the nozzle just contact with the A4 paper and that the A4 paper can move smoothly with slight friction.



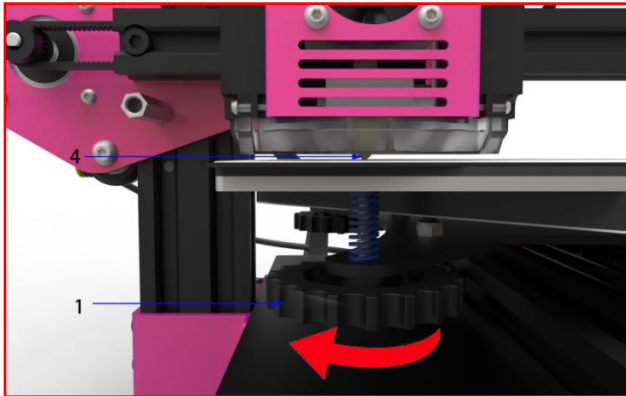
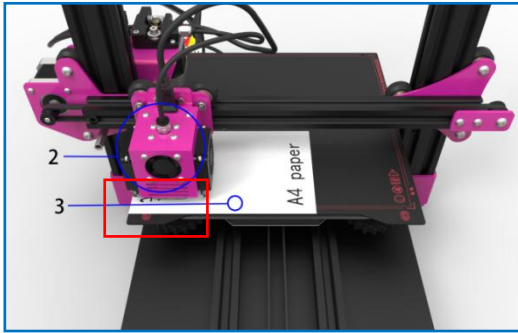
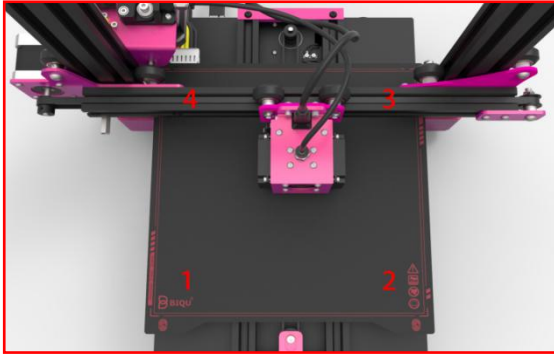



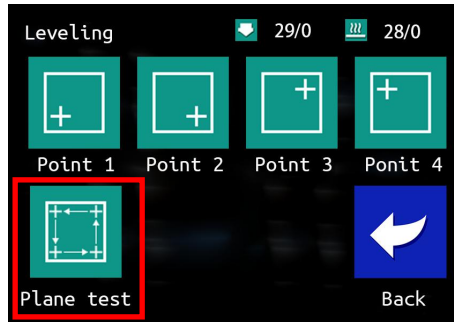

When users turn the hand-screw nut clockwise, the platform will rise, and when users turn the nut clockwise, the platform will fall.

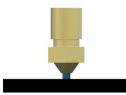

In the same way, touch the "second point", "third point" and "fourth point" on the screen in turn, and use the same method to turn the hand-screw nut under the platform to manually level the platform.

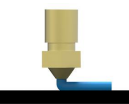
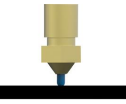
**Step 3** After manual leveling, you can click "Plane test" in the previous operation interface, the printer starts printing, and the customer can evaluate the leveling effect of the platform based on the printing effect for the next optimization.

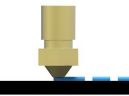

			<p>The distance between the nozzle and the platform is appropriate, and the <b>extruded</b> filaments stick to the printing platform.</p>
			<p>If the distance between the nozzle and the platform becomes too long, it will cause the extruded filament leaving printing platform. User should twist the nut slightly and clockwise to raise the platform a little bit.</p>
			<p>If the distance between the nozzle and the platform becomes too close, it will cause damage to the nozzle and printing platform. User should twist the nut slightly and clockwise to low down the platform.</p>

## 7-2 Automatic Leveling (Optional)

This function may require customers to purchase BLtouch, and install it on the BLtouch stand of the 3D printer.

Choose from the touch screen homepage ① “ Menu ” → ② “ Movement ” → ③ “ ABL ” → ④ “ ABL ” 。

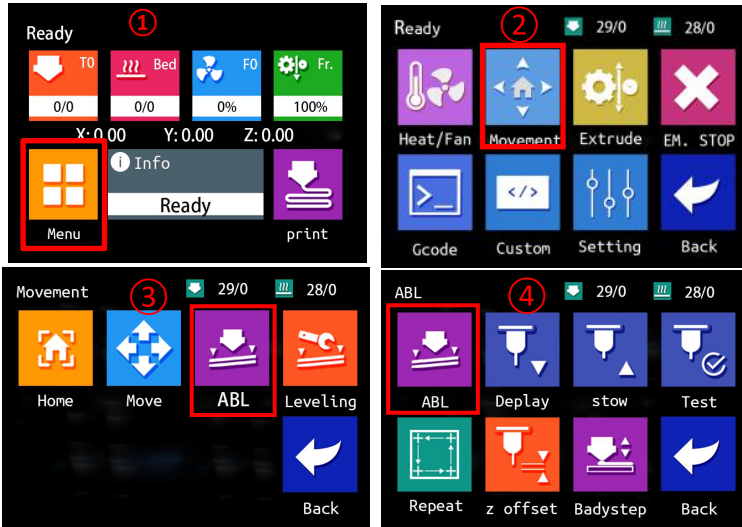

Note: If users does not install BLtouch on BIQU-B1 or does not install it properly, the touch screen will pop up a prompt window, as shown below:

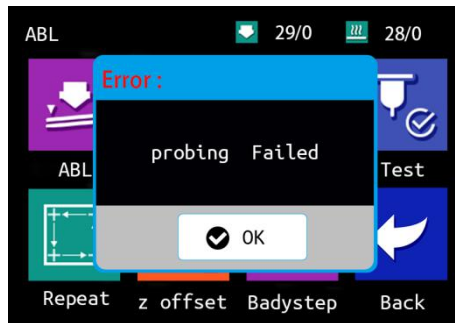

The 3D printer starts to level automatically, the BLtouch probe descends, and the nozzle head also descends. Until the probe touches the first point of the platform, and the probe and nozzle start to rise. After the first point, the nozzle-head would move above to the second point and repeat this operation until all the 25 points on the platform are tested.

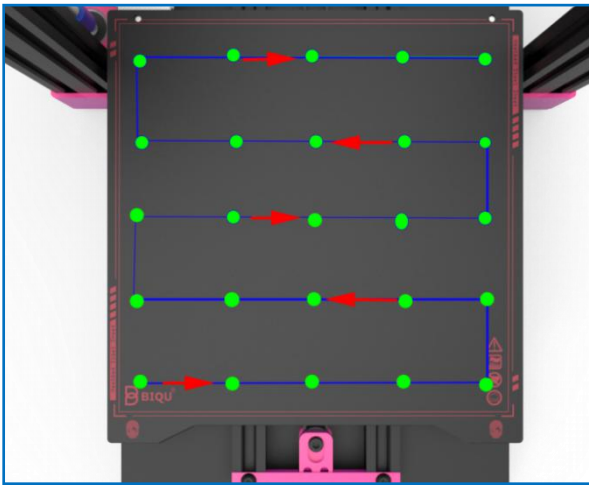

After finishing the automatic leveling, user can click "Repeat" in the previous operation interface, the printer starts printing, and the users can evaluate the leveling effect of the platform based on the printing effect to optimize the next step.

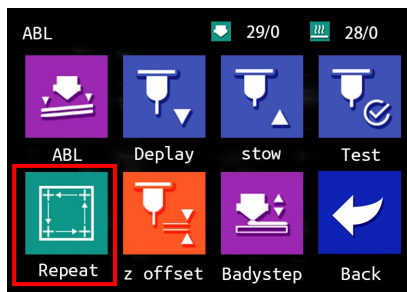

## 7-3 Intelligent filament detection Sensor Module

### (Optional)

If users has a higher pursuit, users can additionally purchase a smart filament detection sensor module, and upgrade filament run out detection module into an intelligent filament detection sensor module.

First, users remove the filament run out detection module from BIQU-B1, and then installs the smart filament sensor module. Choosing from the homepage of the 3D printer touch screen ① “Menu” → ② “Settings” → ③ “Feature” → ④ “Page down” → ⑤ “Filament sensor”.

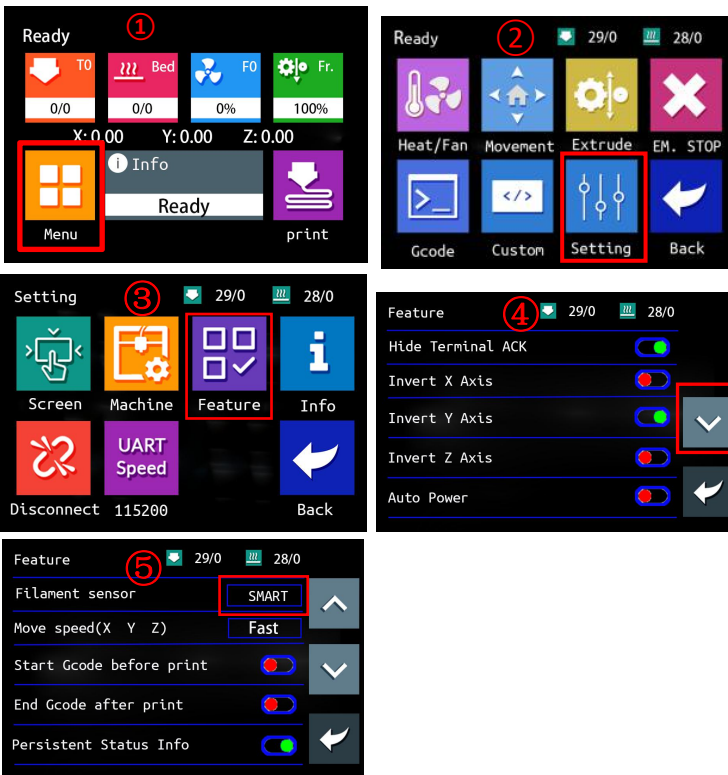

On the option of Filament Sensor if shows “SMART” indicating that the intelligent filament detection function is turned on.

Supplements:

When the button of "Filament Sensor" shows "ON", owes to filament run-out detection module, BIQU-B1 starts detecting filament run out status.

When the button of "Filament Sensor" shows "intelligent", owes to smart filament detection sensor module, BIQU-B1 starts detecting filament-jam status.

When the button of "Filament Sensor" shows "OFF", BIQU-B1 would neither detect filament run out nor filament-jam status.

Normally, BIQU-B1 defaults to open filament run-out detection function.

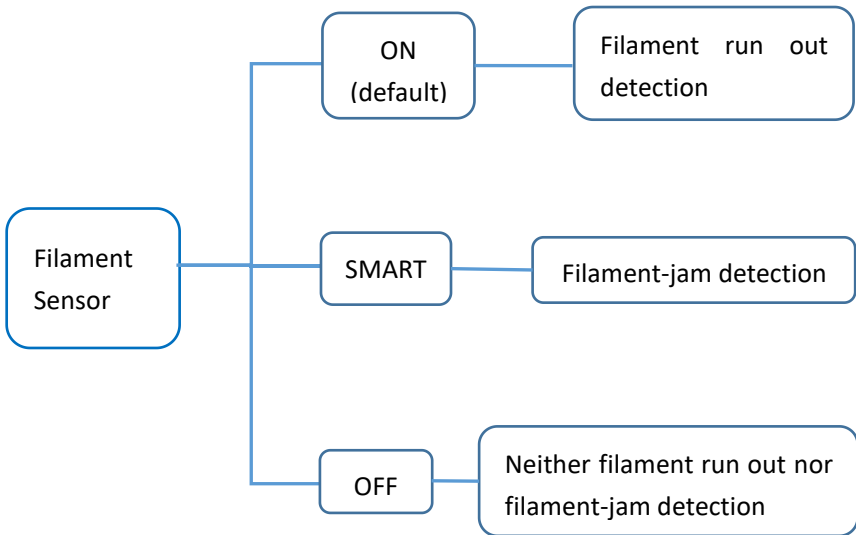



## 7-4 Model Preview

When there are many 3D printed files in the TF card, it is difficult for users to find the files they needed. The model preview function can help users find their target files more quickly and directly.

The function will be described in detail below.

### Step 1

Select the buttons in sequence on the touch screen: ① “Menu” → ② “Setting” → ③ “Info”. The current screen firmware version will be displayed on the screen: TFT35\_V3.0.26.x DEC 29 2020 ( “DEC 29 2020” represents the firmware version update date). If the current screen firmware version date is after Jul 1st 2020, you do not have to update the screen firmware. Otherwise, you need to update the screen firmware. The new version of the screen firmware link is as follows:

<https://github.com/bigtreetech/BIQU-B1/tree/master/Firmware>

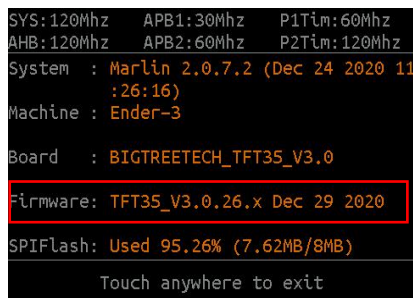
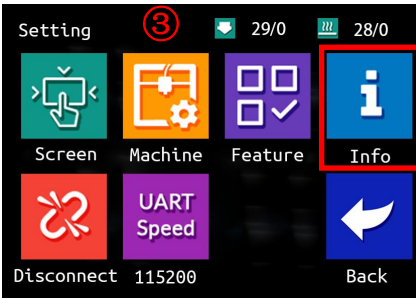
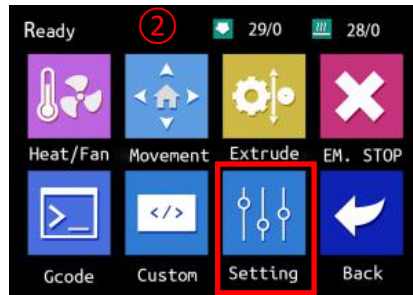
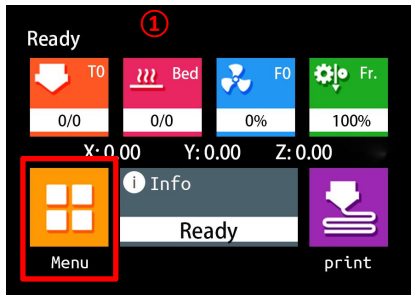

## Step 2

Download the “Bigtree3DPlugin Suit” compressed package, and then unzip it to obtain the plug-in file with the model preview function.

The link to download “Bigtree3DPlugin Suit” compressed package is:  
<https://github.com/bigtreotech/Bigtree3DPluginSuit>

Find the plug-in folder of Ultimaker Cura software. Then copy the plug-in file of the model preview function of "Bigtree3DPlugin Suit" to the plug-in folder of Ultimaker Cura software.

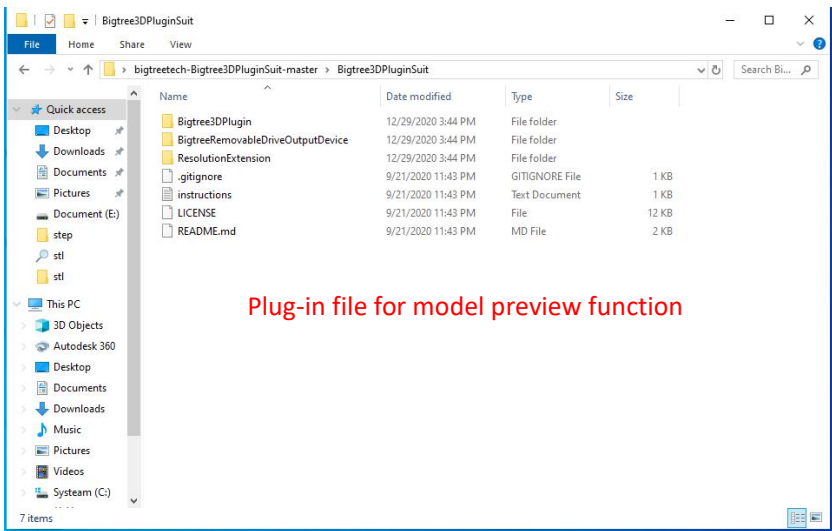

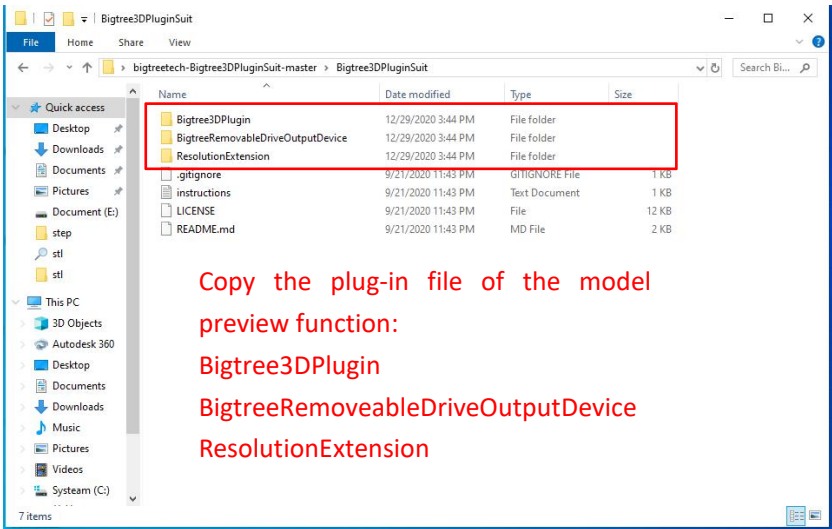
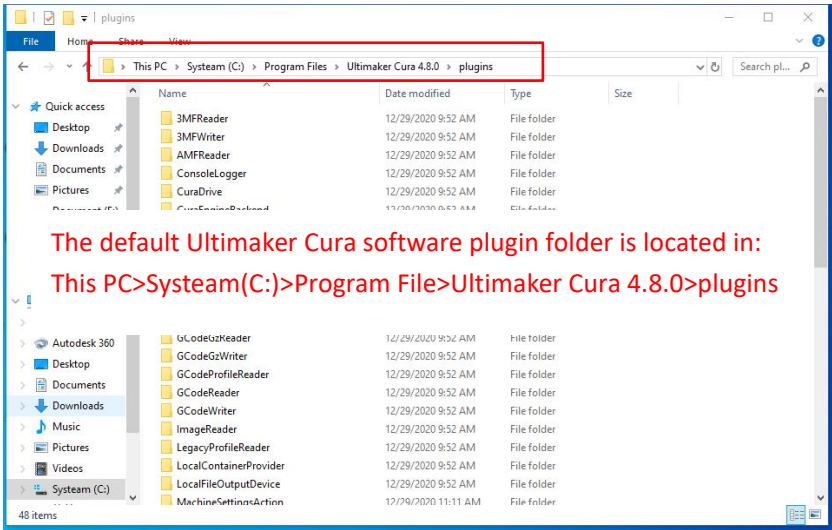

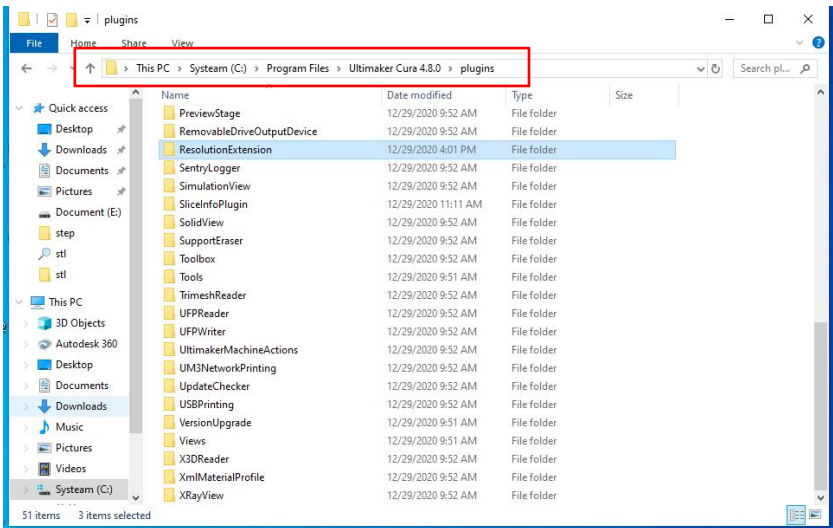
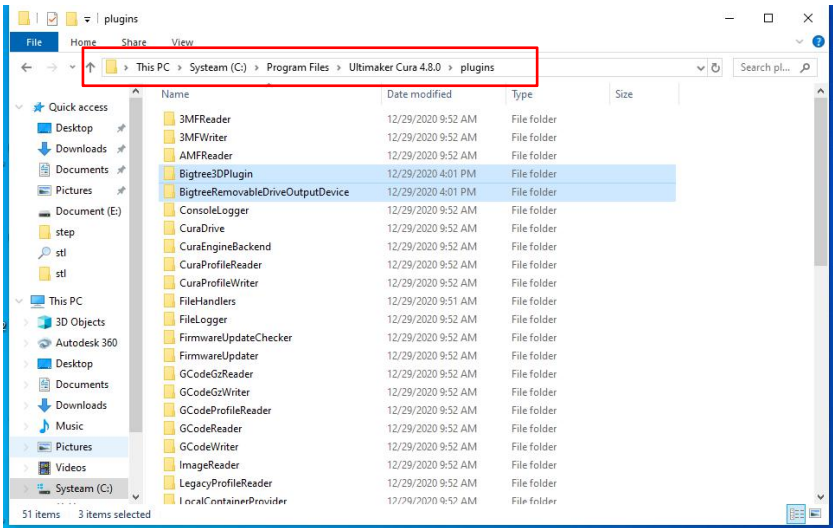

Copy the plug-in file of the model preview function for "Bigtree3DPlugin Suit" to the plug-in folder of Ultimaker Cura software.

## Step 3

Reopen the Ultimaker Cura software, and slice the model file in stl format. Then click the "Save as Bigtree3D format" button to save the G-code file to the root directory of the TF card.

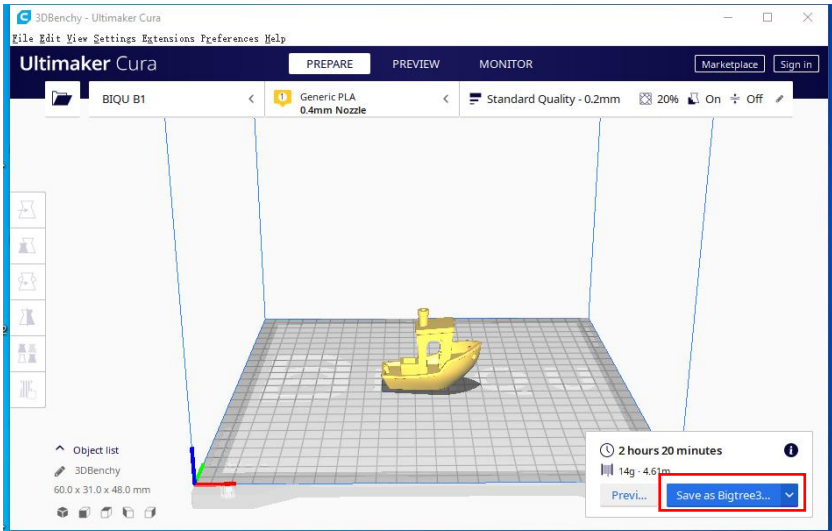
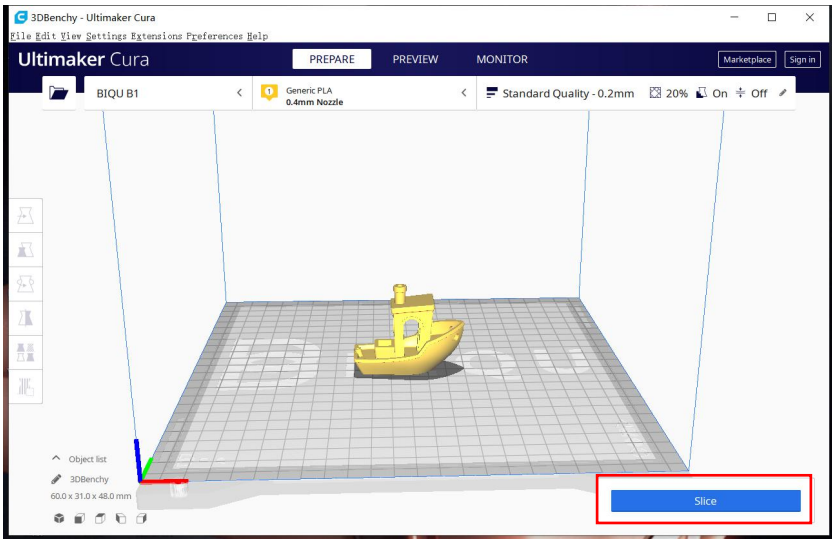

**Step 4** Choose from the touch screen homepage ① “Menu” → ② “Settings” → ③ “Feature” → ④ “Page down” → ⑤ “Page down” → ⑥ “Files Viewer List Mode” 。

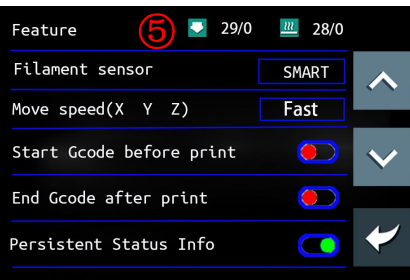
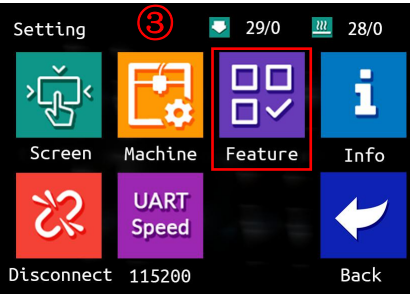
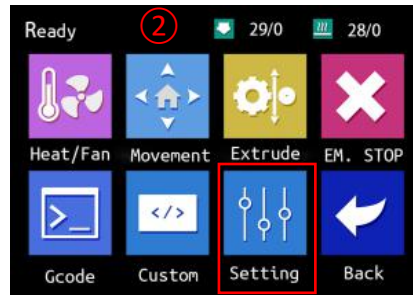
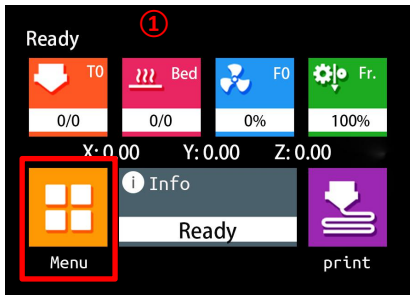

When “Files Viewer List Mode” option turns red, it means that the machine has opened the file browsing mode.

## Step 5

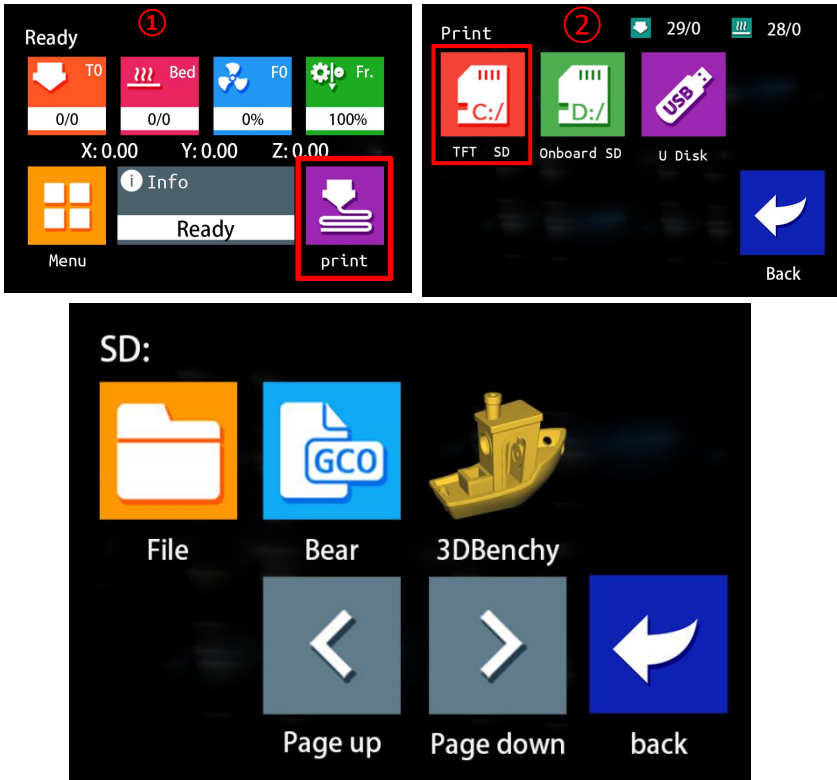

Choose from the touch screen homepage① “Print” →② “TFT SD” , and when selecting the slice file saved in the TF card, users will see the interface of the print file has been changed. The outputted sliced files will display thumbnail icons, while without outputted sliced files will not display thumbnail icons. Users could select the slice file they want to print at a glance.

## 7-5 Marlin Operating System

BIQU-B1 has also equipped with a retro-style Marlin operating system, users can choose their favorite operating system according to their own preferences. Below is a brief description of the system.

**Step 1** Long press the knob next to the touch screen, select "Marlin Mode" on the left, then Marlin operating system will appear on the touch screen.

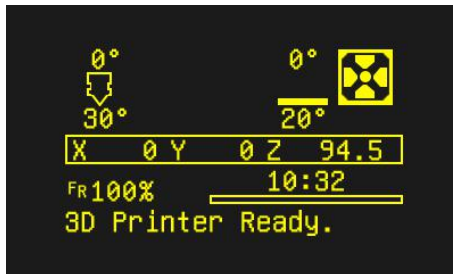
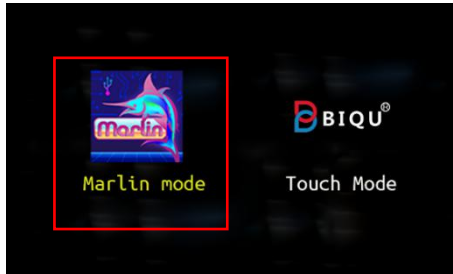



**Step 2** Short press the knob, it will skip to the operation interface of

① (as shown below) And when the user turns the knob clockwise, the option will move page down. Moving option to ② “Print from Media”, then short pressing the knob, it will skip to the operation interface of ③ (as shown below). Moving down option to the file to be printed ④ and short pressing the knob.

**Note:** In the Marlin system, turn the knob clockwise, the option will move down. Turn the knob counterclockwise and the selection will move up.

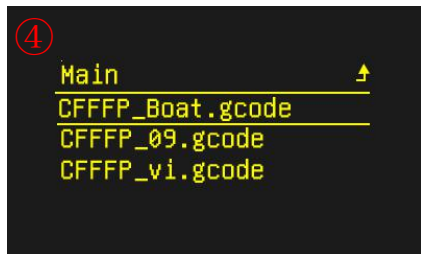
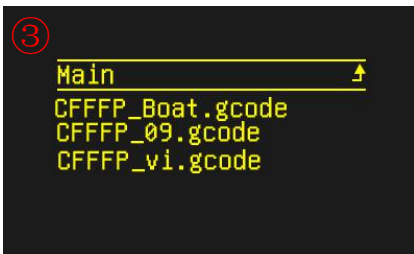
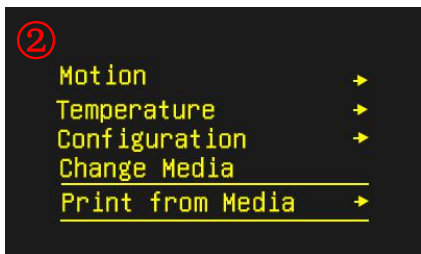
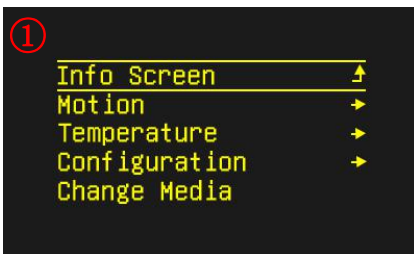

The printer nozzle and hot bed start to heat. After warming to the target temperature, the machine will automatically reset to zero and then start printing.

After printing is completed, the print head and hot bed will automatically cool down. When the temperature of nozzle and hot bed reach indoor temperature, users then can remove the model.

## 8. Troubleshooting

Question 1	<b>layershifting</b>
<b>Answer 1</b>	Printing too fast, please control the speed between 60 ~ 80mm /s.
	The bell pulley or bell might be loosened. Tighten them up.
	The stepper motor is missing steps. The current through the motor might be too small so that the stepper motor doesn't have enough torque. Increase the output voltage from the stepper driver to increase the power of the stepper motor.
	The stepper, stepper driver and the power supply might be overheated. Overheating might affect the performance of steppers.

Question 2	<b>Filament leak</b>
<b>Answer 2</b>	The nozzle is not tightened. Heat up the nozzle and remove the filament before tightening the nozzle with a plier. Do not touch the heated nozzle with your hand!

<b>Question 3</b>	<b>Difficult to install filament</b>
<b>Answer 3</b>	Straighten the end of the filament with your hand, and cut the very end of the filament to a 45 degrees angle with plier.
	The screw on the extruder is too tight, slightly loosen it.
	Filament jam in the white filament tube, heat up to 230 degree and remove the jam filament.

<b>Question 4</b>	<b>Printting edge warping</b>
<b>Answer 4</b>	The nozzle is far away from the platform, adjust the distance between the platform and the nozzle-head.
	Insufficient cooling is possible, make sure the fan is working.
	Providing a closed environment in order to keep the temperature stable.
	Reducing the printing speed and allowing enough time to adjust the temperature change.
	The line width of the first layer is widened, that is, to increase the extrusion amount of the bottom layer.
	Adding Brim support.

<b>Question 5</b>	<b>Bobbling on the top of the print</b>
<b>Answer 5</b>	Insufficient cooling is possible, make sure the fan is working.
	Top layer height is too thin, increase top layer height in your print setting.

<b>Question 6</b>	<b>Cracks and Gaps in 3D prints</b>
<b>Answer 6</b>	Insufficient extrusion. Double check and see if there are any loosen parts in your printer.
	Make sure the diameter of your filament is consistent.
	Add some machine/motor oil on the rail to ensure the print bed and extruder can slide smoothly.

<b>Question 7</b>	<b>During the printing process, the extruder emits the abnormal sound of "Kakaka"</b>
<b>Answer 7</b>	Might be a nozzle jam, you could use needle tools to unblock.
	The quality of the printed materials is not high, you can try another material.
	The print head temperature is too high, and the material is carbonized into small black particles. Try to lower the printing temperature.
	The torque of the feeding part needs to be adjusted.

<b>Question 8</b>	<b>Inconsistent extrusion</b>
<b>Answer 8</b>	Check and see if the filament is jammed.
	Check and see if there is a nozzle jam.
	Double check if you are using the correct layer height and filament size setting.
	You might be using low quality filament that would often break.

<b>Question 9</b>	<b>Stringing</b>
<b>Answer 9</b>	Adjust the retraction setting by 1mm each time and compare the result.
	Change the retraction distance and retraction speed. Generally, the better range of the retraction effect is 20 ~ 100mm / s. If you want to set the most ideal value, you need to experiment to control different speeds to see if the amount of wire is reduced.
	Try lowering the print temperature by 5 degrees each time.
	Lower the travel distance. Lower the distance between each model if you are printing multiple models a time.

## 9. Cautions

1. To prevent scalds, please don't touch the nozzle or the heated bed when the printer is printing.
2. Please don't touch the magnet bed immediately after a print is done, wait for the hot plate to cool down before taking the print out.
3. Place the printer on top of a rigid body, otherwise, print quality might be affected.
4. Don't place your hand inside the printer, avoid getting slam or pinch by the printer.
5. Don't use the printer over 100 hours continuously, otherwise, the machine might overheat and cause damage.
6. For safety, people under 18 must be supervised by adult when using the printer.
7. Don't place the printer near flammable substance. Place your printer at a ventilated, clean and cool environment.
8. Follow the user manual carefully. Disassemble or modify your printer without permission might cause damage to your printer, and the user will be responsible for all the causes.

Shenzhen Bigtree Technology Co.,Ltd

A decorative graphic on the right side of the page. It features a large, vibrant pink splash at the bottom, with several smaller blue splashes scattered above it. Within the pink splash, there are three 3D printed shark models in a reddish-pink color, appearing to be part of the liquid.

Address: 2/F,Building B,No.9 East Area,Shangxue Technology  
Park, Longgang District,Shenzhen,Guangdong,China

Tel: +86 755 3313 3143 +86 137 9898 0050

Email: [support@biqu3d.com](mailto:support@biqu3d.com)

WEB: [www.BIQU.equipment](http://www.BIQU.equipment)