

Product specification & interface for On Board Charger

PROJECT NAME

Standard 3.5 kW GEN2.5 On Board Charger

ABSTRACT / CONCLUSION

Product performance and interface specification for 3.5 kW GEN2.5 OBC.

Part number: EV250035

CIRCULATION list (E: E-mail)

Can be released Communicable with non disclosure commitment Available on site only Confidential - unavailable

D	Name	Service or Company	D	Name	Service or Company
E	Ronny Øen	Software engineer	E		
E	Roar Lindseth	R&D manager	E		
E	Egil Falch Piene	Functional safety engineer	E		
E	Stian Abelsen	Software engineer	E		
E	Stian Abelsen	Software engineer	E		
E	Yingsheng YI	PM	E		
E	Sixiong ZENG	PTM	E		
E			E		
E			E		
E			E		

	Written by	Checked by	Approved by
Function	R&D PTM	P0/P1 R&D Manager	P0/P1 Manager
Name	Sixiong ZENG	Wei WEI	Yingsheng YI
Date			
Visa			

Table of Contents

1. GENERAL INFORMATION	4
1.1 PURPOSE AND SCOPE	4
1.1.1 REQUIREMENTS ATTRIBUTES.....	4
2 SYSTEM DIAGRAM	4
2.1 OBC APPLICATION	4
2.2 CHARGING SYSTEM ARCHITECTURE.....	5
2.3 FUNCTION BLOCK	5
3 OPERATING CONDITION.....	6
3.1 MECHANICAL SPECIFICATION.....	6
3.2 TEMPERATURE.....	7
3.2.1 STORAGE TEMPERATURE	7
3.2.2 OPERATING TEMPERATURE	7
3.3 OPERATION RELATIVE HUMIDITY.....	8
3.4 ALTITUDE.....	9
3.5 COOLING.....	9
3.6 ACOUSTIC NOISE.....	11
3.7 PRODUCT DESIGN LIFE	11
4 INPUTS AND OUTPUTS.....	12
4.1 CONNECTIONS.....	12
4.2 CONNECTOR PIN-OUT.....	12
4.2.1 SIGNAL CONNECTOR.....	12
4.2.2 AC CONNECTOR.....	14
4.2.3 DC CONNECTOR.....	15
5 FUNCTIONS AND GENERAL PERFORMANCE	16
5.1 AC INPUT	16
5.1.1 VOLTAGE	16
5.1.2 CURRENT	17
5.1.3 FREQUENCY	18
5.1.4 POWER FACTOR	18
5.1.5 EFFICIENCY	19
5.2 OUTPUT	19
5.2.1 VOLTAGE	19
5.2.2 VOLTAGE REGULATION.....	20
5.2.3 DYNAMIC RESPONSE	21
5.2.4 RIPPLE.....	21
5.2.5 CURRENT	22
5.2.6 POWER	22
5.3 PROTECTION.....	23
5.3.1 INPUT	23
5.3.2 INTERNAL	24
5.4 TEMPERATURE DERATING	24
5.5 SIGNAL SPECIFICATION.....	25

5.5.1	POWER SUPPLY INPUT (KL30/KL31)	25
5.5.2	HS_CAN	26
5.5.3	INPUT SIGNALS	26
5.6	SIGNAL OUTPUTS	29
5.6.1	OUTPUT FOR LEDS	29
5.6.2	OUTPUT FOR HW WAKE UP	29
5.7	WAKEUP FUNCTION	30
5.7.1	WAKE UP SOURCES	30
5.7.2	WAKE UP FUNCTIONALITY	30
5.8	SAFETY STANDARD	31
5.9	GROUNDING RESISTANCE	32
6	<u>CHARGING PROCEDURE</u>	<u>33</u>
6.1	STATE MACHINE	33
6.2	STATES MODE	34
6.3	TRANSITIONS	36
6.4	SLEEP MODE	37
6.5	CHARGING FUNCTIONS	38

1. GENERAL INFORMATION

1.1 Purpose and scope

This document summarizes the performance and I/O definition for the OBC prototypes. Definitions, acronyms and abbreviations

Definition	Description
OBC	On Board Charger
BMS	Battery management system
ECU	Electronic Controlled Unit
VCU	Vehicle Controlled Unit
GND	Ground
AC	Alternating Current
CCU	Charger Controlled Unit
DSP	Digital signal processor
Eeprom	Electrically erasable programmable read only memory
CAN	Controller Area Network
kbit	Kilobit
DC	Direct current
PFC	Power factor correction
SCI	Serial communication interface

1.1.1 Requirements attributes

Each requirement shall have its unique identifier "**Requirement ID**". In this document, the identifier number of a requirement shall be enumerated according to the following rule: Valeo requirement Name_Version. The Valeo requirement Name following the rule: PTS_R_014010_01_XXX Where XXX is an incremental number.

For any review annotations, remarks or questions please refer to this requirement ID rather than chapter or page numbers.

2 SYSTEM DIAGRAM

2.1 OBC application

The OBC application is shown in figure as below:

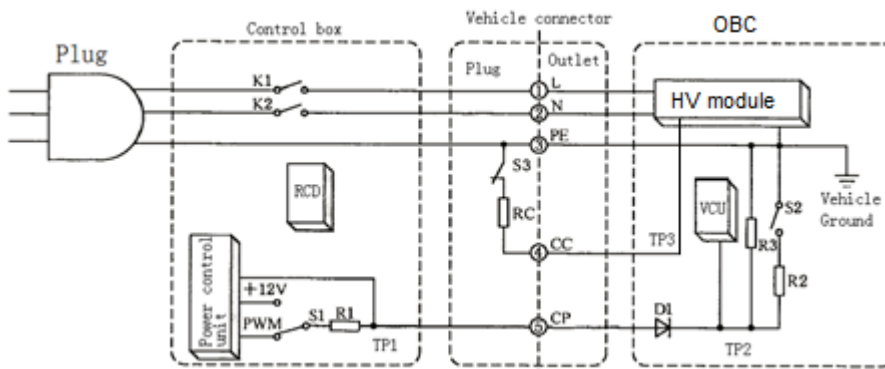

2.2 Charging System architecture

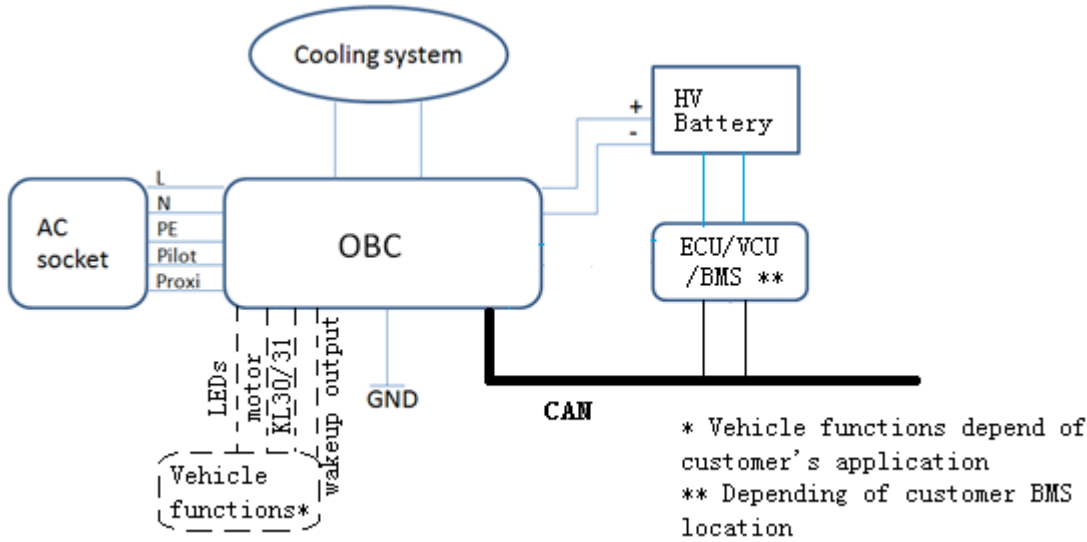

2.3 Function Block

A simplified block description of the charger is shown in the figure below

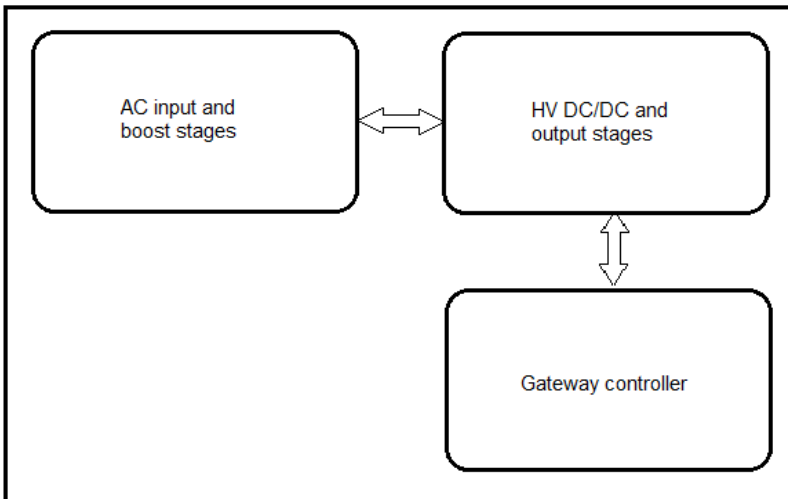

The charger contains a boost converter (PFC) and a DC/DC converter, which are both being controlled by DSPs. The two DSP controller cards are plugged into the mainboard and communicate using SCI.

The primary side DSP is responsible for controlling the input stage, including the PFC and charging of the boost capacitors, whilst the secondary side DSP uses this boost voltage to provide the desired output voltage and current according to the control parameters provided. The two controller cards, together with the mainboard, form the "module".

Inside the charger there is a gateway card, which serves as an interface between the charger and the outside control system(s). The gateway communicates with the secondary controller card using a CAN bus interface.

3 OPERATING CONDITION

3.1 Mechanical specification

The module is a designed to be a part of the Internal specific system.

Requirement ID	PTS_R_014010_01_066.01	Level	Requirement Definition
Safety level *		Requirement type *	Performance
Name *	Dimensions		
Description *	Width: 194mm Height: 69 mm Depth: 310 mm Weight: 3,8 Kg		
Justification			
Reference requirements *	{ }	Verification method	Inspection
Source reference		Source type *	Internal
Source location			
Status *	Accepted	Skill allocation *	Mechanics
Status justification			
Functional group		Function	
Further information			
History	Date *	Name *	Object *
{ First issue }	{ 2016/12/15 }	{ SIXIONG ZENG }	{ Define MK requirement }

Requirement ID	PTS_R_014010_01_067.01	Level	RequirementDefinition
Safety level *		Requirement type *	Performance
Name *	IP level IP		
Description *	The product IP level should be IP67 and IP6K9K.		
Justification			
Reference requirements *	{ }	Verification method	Internal measurement
Source reference		Source type *	Internal
Source location			
Status *	Accepted	Skill allocation *	Mechanics
Status justification			
Functional group		Function	
Further information			
History	Date *	Name *	Object *
{ First issue }	{ 2016/12/15 }	{ SIXIONG ZENG }	{ Define MK requirement }

Requirement ID	PTS_R_014010_01_068.01		Level	RequirementDefinition
Safety level *			Requirement type *	Performance
Name *	Maximum pressure			
Description *	Maximum allowed pressure in the coolant channel is 3.25bar.			
Justification				
Reference requirements *	{ }	Verification method	Internal measurement	
Source reference			Source type *	Internal
Source location				
Status *	Accepted	Skill allocation *	Mechanics	
Status justification				
Functional group			Function	
Further information				
History	Date *	Name *	Object *	
{ First issue }	{ 2016/12/15 }	{ SIXIONG ZENG }	{ Define MK requirement }	

3.2 Temperature

3.2.1 Storage temperature

Requirement ID	PTS_R_014010_01_019.01		Level	RequirementDefinition
Safety level *			Requirement type *	Performance
Name *	Storage temperature			
Description *	{ -40°C to +105°C }			
Justification				
Reference requirements *	NONE	Verification method	QualificationTest	
Source reference			Source type *	Internal
Source location				
Status *	Accepted	Skill allocation *	Hardware/MK	
Status justification				
Functional group			Function	
Further information				
History	Date *	Name *	Object *	
{ First issue }	{ 2016/12/15 }	{ SIXIONG ZENG }	{ Define HW/MK requirement }	

3.2.2 Operating temperature

Requirement ID	PTS_R_014010_01_020.02		Level	RequirementDefinition
Safety level *			Requirement type *	Performance

Name *	Operating temperature		
Description *	<p>The Ambient temperature range is: -40°C to +60°C.</p> <p>The performance of the charger as a function of the coolant temperature is Below -40 °C => the charger shall shut down. -39°C to -10°C => full power, reduced performance of ripple. -11°C to +60 °C => full power >61°C => reduced output power till turn off</p> <p>Operating ambient temperature range: -40° C~ +85 °C, The OBC shall be not directly onto units within the front chamber that has a higher temperature than the coolant, and insure coolant temperature below 60°C, >8L/min flow-rate.[02]</p>		
Justification			
Reference requirements *	NONE	Verification method	Qualification Test
Source reference		Source type *	Internal
Source location			
Status *	Accepted	Skill allocation *	HW/SW
Status justification			
Functional group		Function	
Further information			
History	Date *	Name *	Object *
{ First issue }	{ 2016/12/15 }	{ SIXIONG ZENG }	{ Define HW/SW requirement }

3.3 Operation relative humidity

Requirement ID	PTS_R_014010_01_078.01	Level	RequirementDefinition
Safety level *		Requirement type *	Environment
Name *	{ Operation relative humidity }		
Description *	5%~95%		
Justification			
Reference requirements *	{ }	Verification method	IntegrationTest
Source reference		Source type *	InternalStandard
Source location			
Status *	Accepted	Skill allocation *	MK/HW
Status justification			
Functional group		Function	
Further information			
History	Date *	Name *	Object *
{ First issue }	{ 2014/7/8 }	{ SIXIONG ZENG }	{ Define HW/MK requirement }

3.4 Altitude

Requirement ID	PTS_R_014010_01_079.01		Level	RequirementDefinition
Safety level *	Analysis Running		Requirement type *	Environment
Name *	{ Altitude }			
Description *	Operation altitude should be lower than 4000m.			
Justification				
Reference requirements *	{ }	Verification method	IntegrationTest	
Source reference		Source type *	InternalStandard	
Source location				
Status *	Accepted		Skill allocation *	MK/HW
Status justification				
Functional group		Function		
Further information				
History	Date *	Name *	Object *	
{ First issue }	{ 2014/7/9 }	{ SIXIONG ZENG }	{ Define HW/MK requirement }	

3.5 Cooling

Requirement ID	PTS_R_014010_01_021.01		Level	RequirementDefinition
Safety level *		Requirement type *	Performance	
Name *	{ Coolant specification }			
Description *	{ <ul style="list-style-type: none"> Integrated cooling channel. Minimum flow for full output power is 2l/min. Coolant medium is 50%/50% water glycol mix. Glycol, BASF G48G 49.5% +/-2.5%, water remaining. Below is the date Measured pressure drop in coolant channel			

Surface area cooling channel (m ²):		0,04		
Heatloss (W):		225		
Water temp IN (degC):		70		
Initial pressure (mBar):		1013,25		
Flow rate (l/min)	Pressure drop (mBar)	dT Water OUT-IN	h = Q/dTxA	Pressure drop measured on rapid prototype (mBar)
0,5	0,2	6,9	818	
1,0	0,7	3,8	1496	
1,5	1,5	2,6	2139	
2,0	2,6	2,0	2771	3,0
2,5	4,1	1,7	3409	
3,0	5,8	1,4	4018	
3,5	7,9	1,2	4611	
4,0	10,2	1,1	5208	
4,5	12,9	1,0	5625	
5,0	15,8	0,9	6320	20,0
5,5	19,1	0,8	7031	
6,0	22,7	0,7	7601	25,0
6,5	26,6	0,7	8152	
7,0	30,7	0,6	8789	
7,5	35,3	0,6	9375	
8,0	40,0	0,6	9868	40,0
8,5	45,1	0,5	10417	45,0
9,0	50,4	0,5	11029	

Pressure drop (mBar)

Flow rate l(/min)

Justification			
Reference requirements *	NONE	Verification method	QualificationTest
Source reference		Source type *	Internal
Source location			
Status *	Accepted	Skill allocation *	Mechanics
Status justification			
Functional group		Function	
Further information			
History	Date *	Name *	Object *
{ First issue }	{ 2016/12/15 }	{ SIXIONG ZENG }	{ Define MK requirement }

3.6 Acoustic noise

Requirement ID	PTS_R_014010_01_022.01		Level	Requirement Definition
Safety level *			Requirement type *	Performance
Name *	{ Acoustic noise }			
Description *	{ < 30dBA at nominal input and full load. }			
Justification				
Reference requirements *	NONE	Verification method	Qualification Test	
Source reference			Source type *	Internal
Source location				
Status *	Accepted	Skill allocation *	Mechanics	
Status justification				
Functional group			Function	
Further information				
History	Date *	Name *	Object *	
{ First issue }	{ 2016/12/15 }	{ SIXIONG ZENG }	{ Define MK requirement }	

3.7 Product design life

Requirement ID	PTS_R_014010_01_083.01		Level	Requirement Definition
Safety level *	Analysis Running		Requirement type *	Performance
Name *	{ Product design life }			
Description *	{ The product design life shall be higher than 10 years or 300,000km at 100% load @ 25 C coolant temperature. Charging condition: 8 charging hours per day, 365 days per year; 3km per 1KWh }			
Justification				
Reference requirements *	{ }	Verification method	IntegrationTest	
Source reference			Source type *	InternalStandard
Source location				
Status *	Accepted	Skill allocation *	Quality	
Status justification				
Functional group			Function	
Further information				
History	Date *	Name *	Object *	
{ First issue }	{ 2014/11/28 }	{ SIXIONG ZENG }	{ Define HW/MK requirement }	

4 INPUTS AND OUTPUTS

4.1 Connections

Requirement ID	PTS_R_014010_01_036.01		Level	Requirement Definition
Safety level *		Requirement type *	Interface	
Name *	{ Connections }			
Description *	<p>DC connector Signal connector AC connector Water connector</p>			
Justification				
Reference requirements *	NONE	Verification method	Inspection	
Source reference		Source type *	Internally Derived	
Source location				
Status *	Accepted	Skill allocation *	HW/Mechanics	
Status justification				
Functional group		Function		
Further information				
History	Date *	Name *	Object *	
{ First issue }	{ 2016/12/15 }	{ SIXIONG ZENG }	{ Define HW/Mechanics requirement }	

4.2 Connector pin-out

4.2.1 Signal Connector

Requirement ID	PTS_R_014010_01_037.01		Level	Requirement Definition																
Safety level *		Requirement type *	Interface																	
Name *	{ Signal Connector }																			
Description *	<table border="1"> <tr> <td colspan="4">Connector on product</td> <td colspan="4">Connector with harness</td> </tr> <tr> <td>Supplier</td> <td>Ref.</td> <td>Nb. Of pins</td> <td>coding</td> <td>Supplier</td> <td>Ref.</td> <td>Nb. Of pins</td> <td>coding</td> </tr> </table>				Connector on product				Connector with harness				Supplier	Ref.	Nb. Of pins	coding	Supplier	Ref.	Nb. Of pins	coding
Connector on product				Connector with harness																
Supplier	Ref.	Nb. Of pins	coding	Supplier	Ref.	Nb. Of pins	coding													

Molex	Header, CMC, 32way Molex64334-0100	32 pins		Molex	Header, receptacle, 32way MOLEX 64319-3211 CONTACT,SOCKET, 24- 22AWG, CRIMP, CMC	32pins	
Pins definition as below:							
1A							
1B							
1C							
1D							
1E	LED1_1						
1F	LED1_2						
1G							
1H	KL30 (+12V)						
2A	HW Wakeup output						
2B							
2C							
2D							
2E							
2F	LED1_GND						
2G							
2H							
3A	PILOT_CONTROL (CP)						
3B	PROXIMITY (CC) (optional)						
3C							
3D							
3E							
3F							
3G							
3H							
4A	HS_CAN_H						
4B	HS_CAN_L						
4C	HVIL+						
4D	HVIL-						
4E							
4F							
4G	KL31						
4H							

Justification			
Reference requirements *	NONE	Verification method	Unit Test
Source reference		Source type *	Internally Derived
Source location			
Status *	Accepted	Skill allocation *	Mechanics/Hardware
Status justification			
Functional group		Function	
Further information			
History	Date *	Name *	Object *
{ First issue }	{ 2016/12/15 }	{ SIXIONG ZENG }	{ Define MK/HW requirement }

4.2.2 AC Connector

Requirement ID	PTS_R_014010_01_038.01			Level	Requirement Definition			
Safety level *				Requirement type *	Interface			
Name *	{ AC Connector }							
Description *	Connector on product				Connector with harness			
	Supplier	Ref.	Nb. Of pins	coding	Supplier	Ref.	Nb. Of pins	coding
	Tyco	1587973-1	3pins Pin 1: Live Pin 2: PE Pin 3: Neutral		Tyco	1587715-1	3pins	

Justification			
Reference requirements *	NONE	Verification method	Unit Test
Source reference		Source type *	Internally Derived
Source location			
Status *	Accepted	Skill allocation *	Mechanics/HW
Status justification			
Functional group		Function	
Further information			
History	Date *	Name *	Object *
{ First issue }	{ 2016/12/15 }	{ SIXIONG ZENG }	{ Define Mechanics/HW requirement }

4.2.3 DC Connector

Requirement ID	PTS_R_014010_01_039.01			Level	Requirement Definition			
Safety level *				Requirement type *	Interface			
Name *	{ DC Connector }							
Description *	Connector on product				Connector with harness			
	Supplier	Ref.	Nb. Of pins	coding	Supplier	Ref.	Nb. Of pins	coding
	Tyco	2103124-4	4 pins Pin 1: Positive Pin 2: Negative 2pins: HVIL		Tyco	1587819-4	2pins	

Justification			
Reference requirements *	NONE	Verification method	Unit Test
Source reference		Source type *	Internally Derived
Source location			
Status *	Accepted	Skill allocation *	Mechanics/Hardware
Status justification			
Functional group		Function	
Further information			
History	Date *	Name *	Object *
{ First issue }	{ 2016/12/15 }	{ SIXIONG ZENG }	{ Define MK/HW requirement }

5 FUNCTIONS AND GENERAL PERFORMANCE

5.1 AC Input

5.1.1 Voltage

Requirement ID	PTS_R_014010_01_001.01	Level	Requirement Definition
Safety level *		Requirement type *	Performance
Name *	{ Input voltage }		
Description *	{ Input voltage range }		

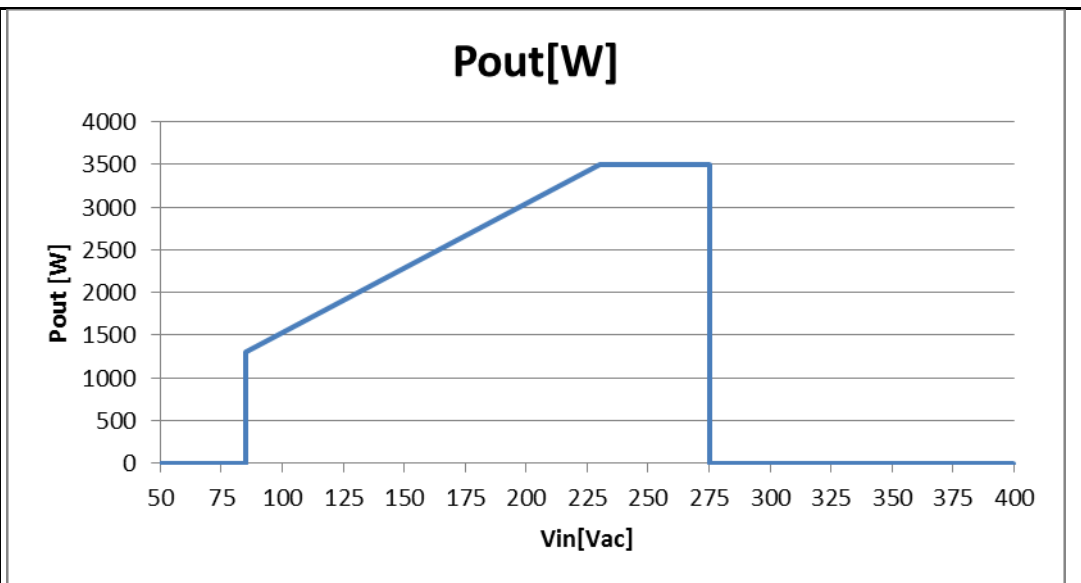

Figure 1: Output power vs. input voltage for AC input

Nominal:	230 Vac	
Range:	230 - 275 Vac	Full output power
Low voltage 1:	0 – 85 Vac	Shut-down
Low voltage 2:	85 – 230 Vac	Max lin 16A.
High voltage 1:	>275 Vac	Shut-down.
Warning:	>300 Vac	Not allowed, will damage the unit.

- All electrical parts what could be touched in AC input port should drop to lower than 60VAC RMS in 1 second when AC input turns off.
- Input AC voltage measurement accuracy is ± 3%.

Justification			
Reference requirements *	NONE	Verification method	Integration Test
Source reference		Source type *	Internal
Source location			
Status *	Accepted	Skill allocation *	HW/SW
Status justification			
Functional group		Function	
Further information			
History	Date *	Name *	Object *
{ First issue }	{ 2016/12/15 }	{ SIXIONG ZENG }	{ Define HW/SW requirement }

5.1.2 Current

Requirement ID	PTS_R_014010_01_002.01	Level	Requirement Definition
Safety level *		Requirement type *	Performance
Name *	{Input Current }		
Description *	<ul style="list-style-type: none"> • Nominal: 16.0 Arms at 230 Vrms at full load. • Maximum: 16.0 Arms at 85-230Vrms input and available full load • Inrush< 6 Arms peak. 		

	<ul style="list-style-type: none"> Fuses on the input for short circuit protection. Input AC current accuracy is $\pm 2\%$. 		
Justification			
Reference requirements *	NONE	Verification method	Integration Test
Source reference		Source type *	Internal
Source location			
Status *	Accepted	Skill allocation *	HW/SW
Status justification			
Functional group		Function	
Further information			
History	Date *	Name *	Object *
{ First issue }	{ 2016/12/15 }	{ SIXIONG ZENG }	{ Define HW/SW requirement }

5.1.3 Frequency

Requirement ID	PTS_R_014010_01_003.01	Level	Requirement Definition
Safety level *		Requirement type *	Performance
Name *	{AC mains Frequency}		
Description *	Nominal Range: 45 - 66 Hz AC input frequency <44 or >66 are not supported.		
Justification			
Reference requirements *	NONE	Verification method	Integration Test
Source reference		Source type *	Internal
Source location			
Status *	Accepted	Skill allocation *	Hardware
Status justification			
Functional group		Function	
Further information			
History	Date *	Name *	Object *
{ First issue }	{ 2016/12/15 }	{ SIXIONG ZENG }	{ Define HW requirement }

5.1.4 Power Factor

Requirement ID	PTS_R_014010_01_004.01	Level	Requirement Definition
Safety level *		Requirement type *	Performance
Name *	{ Power factor }		
Description *	{ > 0.99 at 50% to 100% load, @nominal input voltage and Vout = 360V. > 0.89 at 15% to 50% load, @nominal input voltage and Vout = 360V. }		

Justification			
Reference requirements *	NONE	Verification method	Integration Test
Source reference		Source type *	Internal
Source location			
Status *	Accepted	Skill allocation *	Hardware
Status justification			
Functional group		Function	
Further information			
History	Date *	Name *	Object *
{ First issue }	{ 2016/12/15 }	{ SIXIONG ZENG }	{ Define HW requirement }

5.1.5 Efficiency

Requirement ID	PTS_R_014010_01_005.01	Level	Requirement Definition												
Safety level *		Requirement type *	Performance												
Name *	Product Efficiency														
Description *	<table border="1" style="margin-left: auto; margin-right: auto;"> <thead> <tr> <th>Input voltage</th> <th>Output voltage</th> <th>Loading range</th> <th>Efficiency</th> </tr> </thead> <tbody> <tr> <td>230Vac</td> <td>360Vdc</td> <td>100% load</td> <td>> 93%</td> </tr> <tr> <td>230Vac</td> <td>360Vdc</td> <td>50% load</td> <td>> 94%</td> </tr> </tbody> </table> <p>Test situation: Coolant temperature range: -10° C to 60° C.</p>			Input voltage	Output voltage	Loading range	Efficiency	230Vac	360Vdc	100% load	> 93%	230Vac	360Vdc	50% load	> 94%
Input voltage	Output voltage	Loading range	Efficiency												
230Vac	360Vdc	100% load	> 93%												
230Vac	360Vdc	50% load	> 94%												
Justification															
Reference requirements *	NONE	Verification method	IntegrationTest												
Source reference		Source type *	Internal												
Source location															
Status *	Accepted	Skill allocation *	Hardware												
Status justification															
Functional group		Function													
Further information															
History	Date *	Name *	Object *												
{ First issue }	{ 2016/12/15 }	{ SIXIONG ZENG }	{ Define Electrical requirement }												

5.2 Output

5.2.1 Voltage

Requirement ID	PTS_R_014010_01_010.02	Level	RequirementDefinition
Safety level *		Requirement type *	Performance
Name *	{ Output voltage }		

Description *	Output voltage range: 180V ~ 430V Nominal output: 292 ~ 410 Vdc Derated conditions: Between 180V and 292V, the Max. output current is 12A. Between 410V and 430V, the Max. output power linear decrease from 3500W to 500W.		
	<ul style="list-style-type: none"> ➤ Output DC voltage accuracy is $\pm 1\%$. ➤ Passive discharge: All electrical parts what could be touched in DC output port should drop to lower than 60VDC in 120 seconds when DC output turns off. ➤ Active discharge: All electrical parts what could be touched in DC output port should drop to lower than 60VDC in 2 seconds when DC output turns off. ➤ Reverse polarity protection is realized by POKAYOKE of Mechanical type. OBC Without HW reverse polarity protection. 		
Justification			
Reference requirements *	NONE	Verification method	Integration Test
Source reference		Source type *	Internal
Source location			
Status *	Accepted	Skill allocation *	HW/SW
Status justification			
Functional group		Function	
Further information			
History	Date *	Name *	Object *
{ First issue }	{ 2016/12/15 }	{ SIXIONG ZENG }	{ Define HW/SW requirement }

5.2.2 Voltage Regulation

Requirement ID	PTS_R_014010_01_011.01	Level	Requirement Definition
Safety level *		Requirement type *	Performance
Name *	{ Voltage Regulation }		
Description *	Output voltage(>292VDC) Static regulation: $\pm 0.5\%$ for 0 - 100% load and nominal input voltage.		
Justification			
Reference requirements *	NONE	Verification method	Qualification Test
Source reference		Source type *	Internal
Source location			
Status *	Accepted	Skill allocation *	HW/SW
Status justification			
Functional group		Function	
Further information			
History	Date *	Name *	Object *
{ First issue }	{ 2016/12/15 }	{ SIXIONG ZENG }	{ Define HW/SW requirement }

5.2.3 Dynamic response

Requirement ID	PTS_R_014010_01_012.02		Level	RequirementDefinition
Safety level *			Requirement type *	Performance
Name *	Output Dynamic response			
Description *	Load step 100-0%: Voltage Overshoot < 10%. Load step 0-100%: Voltage Rise time <5s, Overshoot <10%. Current should drop to 0A in 100ms when receiving shut down command.			
Justification				
Reference requirements *	NONE	Verification method	Qualification Test	
Source reference		Source type *	Internal	
Source location				
Status *	Accepted	Skill allocation *	Hardware	
Status justification				
Functional group		Function		
Further information				
History	Date *	Name *	Object *	
{ First issue }	{ 2016/12/15 }	{ SIXIONG ZENG }	{ Define Electrical requirement }	

5.2.4 Ripple

Requirement ID	PTS_R_014010_01_013.01		Level	Requirement Definition
Safety level *			Requirement type *	Performance
Name *	Ripple			
Description *	Voltage: < 1% volt peak-peak ripple @output voltage >200V, 30 MHz bandwidth limited measurement Current: Output current ripple< 5% when measured with a resistive load.			
Justification				
Reference requirements *	NONE	Verification method	Qualification Test	
Source reference		Source type *	Internal	
Source location				
Status *	Accepted	Skill allocation *	Hardware	
Status justification				
Functional group		Function		
Further information				
History	Date *	Name *	Object *	
{ First issue }	{ 2016/12/15 }	{ SIXIONG ZENG }	{ Define Electrical requirement }	

5.2.5 Current

Requirement ID	PTS_R_014010_01_014.01		Level	RequirementDefinition
Safety level *			Requirement type *	Performance
Name *	{ Output Current }			
Description *	Maximum: 12 (+/-0.3) Adc in current limitation at < 292V output The output current measurement with an accuracy of $\pm 2\%$ of maximum current (+/- 0.3A)			
Justification				
Reference requirements *	NONE	Verification method	Qualification Test	
Source reference			Source type *	Internal
Source location				
Status *	Accepted	Skill allocation *	HW/SW	
Status justification				
Functional group			Function	
Further information				
History	Date *	Name *	Object *	
{ First issue }	{ 2016/12/15 }	{ SIXIONG ZENG }	{ Define HW/SW requirement }	

5.2.6 Power

Requirement ID	PTS_R_014010_01_015.01		Level	RequirementDefinition
Safety level *			Requirement type *	Performance
Name *	{ Output Power }			
Description *	Nominal: 3500W output at nominal input voltage. Power limit : adjustable 0 - 100 % Constant power: 292 - 410Vdc Derating power : 180-292Vdc Max output current 12A. 410 – 430Vdc, Linear derating from 3500W to 500W. Constant current: adjustable 0-12A. 0-12A			

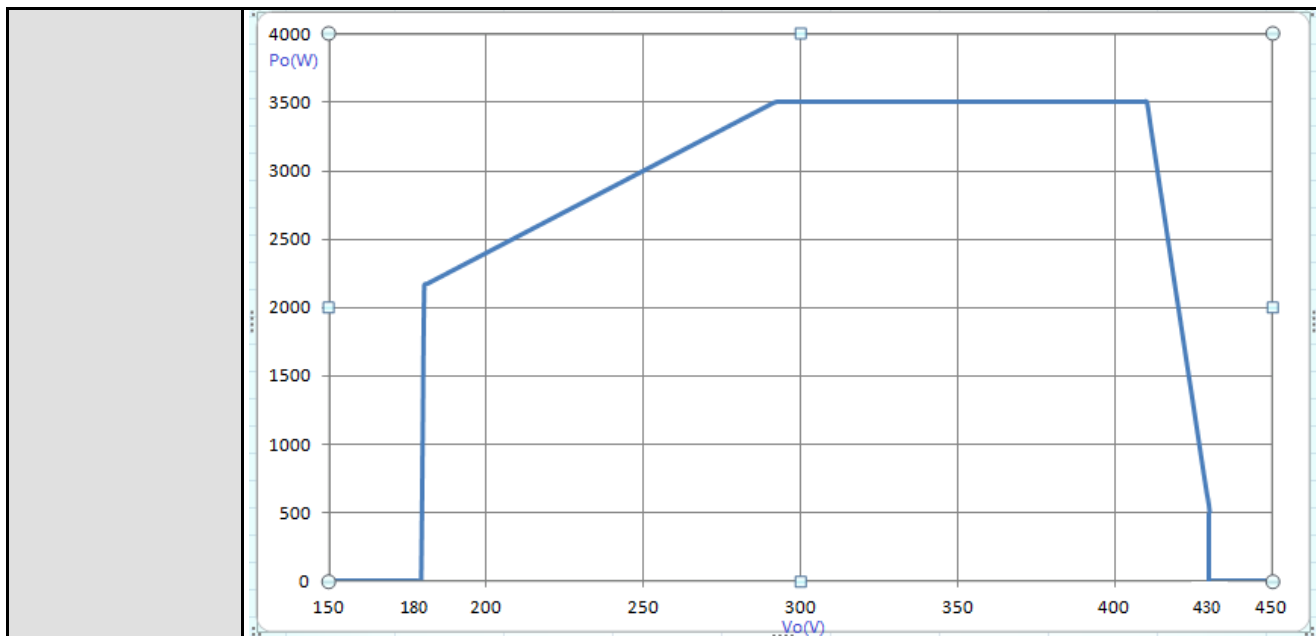

Figure 6: Available output power as a function of output voltage

Justification			
Reference requirements *	NONE	Verification method	Qualification Test
Source reference		Source type *	Internal
Source location			
Status *	Accepted	Skill allocation *	HW/SW
Status justification			
Functional group		Function	
Further information			
History	Date *	Name *	Object *
{ First issue }	{ 2016/12/15 }	{ SIXIONG ZENG }	{ Define HW/SW requirement }

5.3 Protection

5.3.1 Input

Requirement ID	PTS_R_014010_01_016.01	Level	Requirement Definition
Safety level *		Requirement type *	Performance
Name *	{ Input protection }		
Description *	The OBC input withstand a power surge of 400Vrms between phase-neutral for 1 second without damage. Make sure that the charger is unaffected by this and resumes normal operation.		
Justification			
Reference requirements *	NONE	Verification method	QualificationTest
Source reference		Source type *	Internal
Source location			

Status *	Accepted	Skill allocation *	Hardware
Status justification			
Functional group	Function		
Further information			
History	Date *	Name *	Object *
{ First issue }	{ 2016/12/15 }	{ SIXIONG ZENG }	{ Define Electrical requirement }

5.3.2 Internal

Requirement ID	PTS_R_014010_01_018.01	Level	RequirementDefinition
Safety level *		Requirement type *	Performance
Name *	{ Internal protection }		
Description *	<p>The charger has several internal protection features:</p> <ul style="list-style-type: none"> • Low input voltage: If the input voltage drops below 85Vrms the module shuts down. • High input voltage: If the input voltage is greater than 275Vac or 275Vdc the charger will go into self-protective mode. • High output voltage: The charger will shut down if the output voltage exceeds 450Vdc. The charger will be damaged if the output port voltage exceeds 600Vdc. • High temperature: The charger has three internal temperature sensors used for derating and shut-down. The point of derating and shut down depends on the actual load. The unit is self-protecting for any cooling and load combination. • Short circuit: The module is short circuit proof, and shuts down when the output voltage drops below 170V. 		
Justification			
Reference requirements *	NONE	Verification method	Qualification Test
Source reference		Source type *	Internal
Source location			
Status *	Accepted	Skill allocation *	HW/SW
Status justification			
Functional group	Function		
Further information			
History	Date *	Name *	Object *
{ First issue }	{ 2016/12/15 }	{ SIXIONG ZENG }	{ Define HW/SW requirement }

5.4 Temperature derating

Requirement ID	PTS_R_014010_01_031.01	Level	RequirementDefinition
Safety level *		Requirement type *	Functional

Reference requirements *	NONE	Verification method	Unit Test
Source reference		Source type *	Internally Derived
Source location			
Status *	Accepted	Skill allocation *	Hardware
Status justification			
Functional group		Function	
Further information			
History	Date *	Name *	Object *
{ First issue }	{ 2016/12/15 }	{ SIXIONG ZENG }	{ Define Hardware requirement }

5.5.2 HS_CAN

Requirement ID	PTS_R_014010_01_040.02	Level	RequirementDefinition
Safety level *		Requirement type *	Functional
Name *	{ HS_CAN (between vehicle and gateway) }		
Description *	{ CAN baud rate, CAN: 500 Kbit No termination resistor Do the CAN communication between vehicle and gateway board with CAN2.0. Custom develop of the CAN mailbox database according to customer's requirements.[02] }		
Justification			
Reference requirements *	NONE	Verification method	IntegrationTest
Source reference		Source type *	InternallyDerived
Source location			
Status *	Accepted	Skill allocation *	SW/HW
Status justification			
Functional group		Function	
Further information			
History	Date *	Name *	Object *
{ First issue }	{ 2016/12/15 }	{ SIXIONG ZENG }	{ Define SW/HW requirement }

5.5.3 Input signals

5.5.3.1 Interlock of connectors (HVIL+/HVIL-)

Requirement ID	PTS_R_014010_01_052.01	Level	RequirementDefinition
Safety level *		Requirement type *	Functional
Name *	{ Interlock of connectors }		
Description *	{ The charger is equipped with an interlock loop that runs from the signal connector through		

	the DC-connector. See requirement ID: PTS_R_014010_01_039.01. The resistance between HVIL+ and HVIL- in the signal connector will be short circuit when DC-connector is mated, and open circuit when not mated. The Max. current capability of short circuit is 100mA. The OBC shall not detect HVIL interlock signal. }		
Justification			
Reference requirements *	NONE	Verification method	IntegrationTest
Source reference		Source type *	Internally Derived
Source location			
Status *	Accepted	Skill allocation *	HW/SW/MK
Status justification			
Functional group		Function	
Further information			
History	Date *	Name *	Object *
{ First issue }	{ 2016/12/15 }	{ SIXIONG ZENG }	{ Define HW/SW/MK requirement }

5.5.3.2 Control Pilot (CP)

Requirement ID	PTS_R_014010_01_055.01	Level	RequirementDefinition								
Safety level *		Requirement type *	Functional								
Name *	{ Control Pilot – CP }										
Description *	<p>{</p> <p>The charger shall read, interpret and report the control pilot signal according to standard IEC61851 [Ref.4].</p> <p>The pilot signal has 2 functions. First is to submit the maximum allowed input current from the charging station to the vehicle via a PWM signal (1kHz), second is to monitor the proper ground connection between car and charging station.</p> <p>Both functionalities are described in the standards DIN EN 61851[Ref.4] and the pilot signal monitoring function of the charger is developed according to China Local standards and requirements.</p> <p>The pilot signal parameters are described in the below.</p> <table border="1"> <tr> <td>Voltage range</td> <td>Max. KL30, Min. KL31</td> </tr> <tr> <td>Current range</td> <td><10mA</td> </tr> <tr> <td>Min. duty cycle(0%) voltage</td> <td>KL31</td> </tr> <tr> <td>Max duty cycle(100%) voltage</td> <td>KL30</td> </tr> </table> <p>When cable is not connected : No PWM signal is detected When cable is connected : Amplitude is 9V and a PWM signal is detected. When the S2 switch is closed : Amplitude is 6V and the charging station closes its relays (supplies mains)</p> <p>}</p>			Voltage range	Max. KL30, Min. KL31	Current range	<10mA	Min. duty cycle(0%) voltage	KL31	Max duty cycle(100%) voltage	KL30
Voltage range	Max. KL30, Min. KL31										
Current range	<10mA										
Min. duty cycle(0%) voltage	KL31										
Max duty cycle(100%) voltage	KL30										
Justification											
Reference requirements *	NONE	Verification method	IntegrationTest								
Source reference		Source type *	NormAndRegulation								

Source location			
Status *	Accepted	Skill allocation *	HW/SW
Status justification			
Functional group	Function		
Further information			
History	Date *	Name *	Object *
{ First issue }	{ 2016/12/15 }	{ SIXIONG ZENG }	{ Define HW/SW requirement }

5.5.3.3 Proximity signal (CC) – optional function

Requirement ID	PTS_R_014010_01_056.01	Level	RequirementDefinition
Safety level *		Requirement type *	Functional
Name *	{ Proximity signal – CC }		
Description *	{ The charger shall read, interpret and report the proximity signal according to standard IEC61851[Ref.4]. The proximity signal has the functionality to monitor if the charging plug is connected to the car. It is also possible to use this signal to submit the value for the maximum allowed charging cable current. The proximity signal parameters are described in the below. }		
	Voltage range	0-5V	
	Current	<10mA	
	Input impedance	>1MΩ	
	Cable not connected : Signal is approximately floating at 4.16V Cable connected : For type2 the gateway should measure between 2.6 – 3.11 for 16A or 1.59 - 1.91 for 32A. }		
Justification			
Reference requirements *	NONE	Verification method	IntegrationTest
Source reference		Source type *	NormAndRegulation
Source location			
Status *	Accepted	Skill allocation *	SystemEngineering
Status justification			
Functional group	Function		
Further information			
History	Date *	Name *	Object *
{ First issue }	{ 2016/12/15 }	{ SIXIONG ZENG }	{ Define HW/SW requirement }

5.6 Signal outputs

5.6.1 Output for LEDs

Requirement ID	PTS_R_014010_01_058.01		Level	RequirementDefinition										
Safety level *		Requirement type *	Functional											
Name *	{ Output for LEDs }													
Description *	<p>{</p> <p>The charger provides up to 3 outputs for an external RGB LED's. The outputs are PWM controlled. The output voltage is at the same level as the power supply voltage from KL30.</p> <table border="1" style="margin-left: 20px;"> <thead> <tr> <th>LED parameter↕</th> <th>Value↕</th> </tr> </thead> <tbody> <tr> <td>Output voltage↕</td> <td>Same voltage level as KL30↕</td> </tr> <tr> <td>Output frequency↕</td> <td>1000 Hz↕</td> </tr> <tr> <td>Output current↕</td> <td>Max. 55 mA (each LED)↕</td> </tr> <tr> <td>Flicker Frequency</td> <td>0.5 ~10Hz</td> </tr> </tbody> </table> <p>Red on: Charging stopped due to failures (anything in the power stage or gateway) Red flashing: Cable locking/unlocking failed, proximity failure or control pilot failure Green pulsing: Charging ongoing Green on: Charging finished</p> <p>}</p>				LED parameter↕	Value↕	Output voltage↕	Same voltage level as KL30↕	Output frequency↕	1000 Hz↕	Output current↕	Max. 55 mA (each LED)↕	Flicker Frequency	0.5 ~10Hz
LED parameter↕	Value↕													
Output voltage↕	Same voltage level as KL30↕													
Output frequency↕	1000 Hz↕													
Output current↕	Max. 55 mA (each LED)↕													
Flicker Frequency	0.5 ~10Hz													
Justification														
Reference requirements *	NONE	Verification method	UnitTest											
Source reference		Source type *	Internal											
Source location														
Status *	Accepted	Skill allocation *	Hardware/SW											
Status justification														
Functional group		Function												
Further information														
History	Date *	Name *	Object *											
{ First issue }	{ 2016/12/15 }	{ SIXIONG ZENG }	{ Define HW/SW requirement }											

5.6.2 Output for HW wake up

Requirement ID	PTS_R_014010_01_059.01		Level	RequirementDefinition				
Safety level *		Requirement type *	Functional					
Name *	{ Output for HW wake up }							
Description *	<p>{</p> <p>The charger provides 1 output for wake up signal, the current capability is 1A.</p> <table border="1" style="margin-left: 20px;"> <tr> <td>Wakeup output active</td> <td>Output level voltage = KL30-1V(Diode voltage drop)</td> </tr> <tr> <td>Wakeup output inactive</td> <td>Output level voltage = KL31</td> </tr> </table> <p>}</p>				Wakeup output active	Output level voltage = KL30-1V(Diode voltage drop)	Wakeup output inactive	Output level voltage = KL31
Wakeup output active	Output level voltage = KL30-1V(Diode voltage drop)							
Wakeup output inactive	Output level voltage = KL31							
Justification								

Reference requirements *	NONE	Verification method	UnitTest
Source reference		Source type *	Internal
Source location			
Status *	Accepted	Skill allocation *	Hardware
Status justification			
Functional group		Function	
Further information			
History	Date *	Name *	Object *
{ First issue }	{ 2016/12/15 }	{ SIXIONG ZENG }	{ Define HW requirement }

5.7 Wake up function

5.7.1 Wake up sources

Requirement ID	PTS_R_014010_01_061.01		Level	RequirementDefinition
Safety level *	QualityManagement		Requirement type *	Environment
Name *	{ Wake up sources }			
Description *	{ The charger has 3 independent wake up sources. - Wake up via CAN message (partial networking) - Wake up via pilot signal - Wake up via proximity signal }			
Justification				
Reference requirements *	NONE	Verification method	None	
Source reference		Source type *	Internal	
Source location				
Status *	Accepted	Skill allocation *	HW/SW	
Status justification				
Functional group		Function		
Further information				
History	Date *	Name *	Object *	
{ First issue }	{ 2016/12/15 }	{ SIXIONG ZENG }	{ Define HW/SW requirement }	

5.7.2 Wake up functionality

Requirement ID	PTS_R_014010_01_062.01		Level	RequirementDefinition
Safety level *		Requirement type *	Functional	
Name *	{ Wake up functionality }			
Description *	{			

	<p>When the charger is in sleep mode the internal power supply for the gateway uC and the charger DSPs is switched off. There is a power supply for only the partial networking CAN transceiver and for a logic which reads the proximity signal and the pilot signal. The CAN transceiver is also in sleep mode and can be woken up via a special CAN message or via a logic change of its wake up input signal.</p> <p><u>Wake up via CAN message (partial networking):</u> In this case the CAN message results in a wake up of the CAN transceiver which is in sleep mode. The CAN transceiver will then switch on the power supply of the gateway uC and the complete charger wakes up. With a network management message on the CAN the charger can be set in sleep mode.</p> <p><u>Wake up via pilot signal:</u> In this case the pilot signal creates a logic change of the wake up input from the CAN transceiver. The CAN transceiver will then switch on the power supply of the gateway uC and the complete charger wakes up.</p> <p>With a network management message on the CAN the charger can be set in sleep mode. If the charger is set in sleep mode during the pilot signal is still valid, the charger will follow this instruction and go in sleep mode. To wake it up again via pilot signal, this signal must first switched off and then switched on again, then the charger wakes up as described above.</p> <p><u>Wake up via proximity signal:</u> In this case the proximity signal creates a logic change of the wake up input from the CAN transceiver. The CAN transceiver will then switch on the power supply of the gateway uC and the complete charger wakes up. With a network management message on the CAN the charger can be set in sleep mode. If the charger is set in sleep mode during the proximity signal is still valid, the charger will follow this instruction and go in sleep mode. To wake it up again via proximity signal, this signal must first be switched off and then switched on again. The charger will then wake up as described above.</p> <p>}</p>		
Justification			
Reference requirements *	NONE	Verification method	UnitTest
Source reference		Source type *	Internal
Source location			
Status *	Accepted	Skill allocation *	BasicSoftware
Status justification			
Functional group		Function	
Further information			
History	Date *	Name *	Object *
{ First issue }	{ 2016/12/15 }	{ SIXIONG ZENG }	{ Define SW requirement }

5.8 Safety standard

Requirement ID	PTS_R_014010_01_028.01	Level	RequirementDefinition
Safety level *		Requirement type *	Performance

Name *	{ Design standard }		
Description *	<ul style="list-style-type: none"> • UL 60950-1/IEC 60950-1 • IEC61000-6-1 (2005), immunity standard for residential, commercial and light-industrial environments: • IEC61000-6-2 (2005), immunity standard for industrial environments: • IEC61000-6-3 (2006)/ A1 (2010), emissions standard for residential, commercial and light-industrial environments: • IEC61000-6-4 (2006)/A1 (2010), emissions standard for industrial environments: • CISPR 25:2008 • ISO 16750-2/3/4 • QC/T 895-2011 • IEC-61851-1 • IEC-61851-21-1 • ISO 26262 		
Justification			
Reference requirements *	NONE	Verification method	QualificationTest
Source reference		Source type *	Internal
Source location			
Status *	Accepted	Skill allocation *	Hardware
Status justification			
Functional group		Function	
Further information			
History	Date *	Name *	Object *
{ First issue }	{ 2016/12/15 }	{ SIXIONG ZENG }	{ Define Electrical requirement }

5.9 Grounding resistance

Requirement ID	PTS_R_014010_01_082.01	Level	RequirementDefinition
Safety level *	AnalysisRunning	Requirement type *	Safety
Name *	{ Grounding resistance }		
Description *	{ The product Grounding resistance shall be less than 0.1ohm. The product shall have clear indication of the grounding point. }		
Justification			
Reference requirements *	{ }	Verification method	IntegrationTest
Source reference		Source type *	InternalStandard
Source location			
Status *	Accepted	Skill allocation *	MK/HW
Status justification			
Functional group		Function	
Further information			
History	Date *	Name *	Object *
{ First issue }	{ 2014/11/28 }	{ SIXIONG ZENG }	{ Define HW/MK requirement }

6 Charging procedure

6.1 State machine

Requirement ID	PTS_R_014010_01_076.01		Level	RequirementDefinition
Safety level *		Requirement type *	Functional	
Name *	{ Charging workflow }			
Description *	<p>{ charging turn on/off logic</p> <pre> stateDiagram-v2 state Off as Off 0xC state Init as Init 0x1 state Sleep as Sleep(Shutdown) 0xB state Standby as Standby 0x2 state Fault as Fault 0x8 state ChargingNormal as Charging Normal 0x4 state ReducedPower as Reduced power 0x9 state Diagnostic as Diagnostic 0xF Off --> Init : T0 Init --> Standby : T1 Standby --> ChargingNormal : T2 Standby --> ReducedPower : T3 Standby --> Fault : T8 ReducedPower --> Fault : T4 Fault --> Standby : T9 Init --> Sleep : T10 Sleep --> Off : T7 ChargingNormal --> ReducedPower : T11 ReducedPower --> ChargingNormal : T12 </pre> <p>}</p>			
Justification				
Reference requirements *	{ }	Verification method	IntegrationTest	
Source reference		Source type *	Internal	
Source location				
Status *	Accepted	Skill allocation *	ApplicativeSoftware	
Status justification				
Functional group		Function		
Further information				
History	Date *	Name *	Object *	
{ First issue }	{ 2014/5/29 }	{ SIXIONG ZENG }	{ Define HW/SW requirement }	

6.2 States mode

Requirement ID	PTS_R_014010_01_074.01	Level	RequirementDefinition					
Safety level *		Requirement type *	Functional					
Name *	{ Operation mode }							
Description *	<p>{</p> <p>The charge control unit is on sleep mode, before wake up signal comes. The OBC is waked up by CC signal in pilot connection. The OBC send the state modes over the CAN with below states. But for the detail procedure need to be defined by customer.</p>							
	<table border="1"> <thead> <tr> <th>Mode</th> <th>Description</th> </tr> </thead> <tbody> <tr> <td></td> <td> <p>In this mode, System is closed, just waiting for wake up signal. The OBC power consumption is less than 0.06W. No AC or DC input to OBC in this mode, PFC and DC/DC is turned off, no any detections, or monitoring, or protection or CAN communication.</p> <p>After receiving T0 (wake up), the OBC can jump to Init mode only.</p> <p>CAN signal ID 0x60A sent by TBOX will wake up the OBC.</p> </td> </tr> <tr> <td>Shut down & Off (Off = sleep)</td> <td> <p>For CAN wake up, the CAN message results in a wake up of the CAN transceiver which is in sleep mode. The CAN transceiver will then switch on the power supply of the gateway uC and complete charger wake up.</p> <p>With a network management message on the CAN, the charger can be set in sleep mode.</p> <p>For CP wakeup, the pilot signal creates a logic change of the wake up input from the CAN transceiver. The CAN transceiver will then switch on the power supply of the gateway uC and complete charger wake up.</p> <p>If the charger is set in sleep mode during the pilot signal is still valid, the charger will follow this instruction and go in sleep mode. To wake it up again via pilot signal, this signal must be first switched off and then switched on again, then the charger wakes up as described above.</p> </td> </tr> </tbody> </table>	Mode	Description		<p>In this mode, System is closed, just waiting for wake up signal. The OBC power consumption is less than 0.06W. No AC or DC input to OBC in this mode, PFC and DC/DC is turned off, no any detections, or monitoring, or protection or CAN communication.</p> <p>After receiving T0 (wake up), the OBC can jump to Init mode only.</p> <p>CAN signal ID 0x60A sent by TBOX will wake up the OBC.</p>	Shut down & Off (Off = sleep)	<p>For CAN wake up, the CAN message results in a wake up of the CAN transceiver which is in sleep mode. The CAN transceiver will then switch on the power supply of the gateway uC and complete charger wake up.</p> <p>With a network management message on the CAN, the charger can be set in sleep mode.</p> <p>For CP wakeup, the pilot signal creates a logic change of the wake up input from the CAN transceiver. The CAN transceiver will then switch on the power supply of the gateway uC and complete charger wake up.</p> <p>If the charger is set in sleep mode during the pilot signal is still valid, the charger will follow this instruction and go in sleep mode. To wake it up again via pilot signal, this signal must be first switched off and then switched on again, then the charger wakes up as described above.</p>	
Mode	Description							
	<p>In this mode, System is closed, just waiting for wake up signal. The OBC power consumption is less than 0.06W. No AC or DC input to OBC in this mode, PFC and DC/DC is turned off, no any detections, or monitoring, or protection or CAN communication.</p> <p>After receiving T0 (wake up), the OBC can jump to Init mode only.</p> <p>CAN signal ID 0x60A sent by TBOX will wake up the OBC.</p>							
Shut down & Off (Off = sleep)	<p>For CAN wake up, the CAN message results in a wake up of the CAN transceiver which is in sleep mode. The CAN transceiver will then switch on the power supply of the gateway uC and complete charger wake up.</p> <p>With a network management message on the CAN, the charger can be set in sleep mode.</p> <p>For CP wakeup, the pilot signal creates a logic change of the wake up input from the CAN transceiver. The CAN transceiver will then switch on the power supply of the gateway uC and complete charger wake up.</p> <p>If the charger is set in sleep mode during the pilot signal is still valid, the charger will follow this instruction and go in sleep mode. To wake it up again via pilot signal, this signal must be first switched off and then switched on again, then the charger wakes up as described above.</p>							

	<p>Standby mode</p>	<p>All modes can jump to Standby except Sleep mode. In Standby mode, check if CP is in the range. -> In this mode, OBC turns on 12V wake up output signal. -> If OBC receives Sleep command, it will go to Sleep & Off mode. -> If OBC receives Start Charging command, it will close S2 switch. -> If test is OK (without any fault), BMS should send one set value (voltage and current in normal range) to OBC. Then OBC turns on circuit and set the output to requested value. Monitoring the output values and send back to OBC by CAN. -> If Start charging command is lost for over 2 minutes, it turns the state to Sleep & Off mode. -> If any fault is detected, it turns the state to Fault mode.</p>
	<p>Init mode</p>	<p>OBC is in self Test mode. After waken up by T0, load EEPROM/default setting. Check if all references are correct. The system need to check following parameters: 1. Communications with BMS. - Communication normally confirmation. 2. Communications with secondary DSP. Checks below parameters are in the range. - Internal temperatures $-40 - +125 \pm 3^{\circ}C$ - Charger mode All warnings and alarms 3. Check if CP is in the range. -> All of the parameters should be checked during self test. If one/some parameter(s) are incorrect, it searches this parameter(s) belongs to which warning/error. Determining the fault Level for each incorrect parameter. If any recoverable fault is detected for over 500ms or any unrecoverable fault is detected, it can turn the mode to Fault. Recoverable faults : DC overvoltage shutdown; High temperature; Low temperature; CAN communication timeout; DC under voltage shutdown. Unrecoverable : Internal SCI communication failure; Module failure. -> No fault and all self tests are OK, Jump to Standby mode</p>

	Charging mode	<p>In Normal charging mode, the OBC check internal parameters determine the charge current if it is able to reach requested value. If yes, start charging with requested value. If not, charging with derated value. It jumps to Standby mode and open S2 switch if Sleep & Off or Stop charging command is received or CP is not connected. It jumps to Fault mode if any fault is detected.</p>		
	Fault mode	<p>In Fault mode, OBC proceeds below actions. ->Turns off HVDC output. ->If Sleep&Off command is received, it jumps to Sleep&Off mode. ->Open S2 switch. -> If the recoverable fault is disappeared anytime in Fault mode, OBC jumps to Standby mode. -> If the fault is recoverable, OBC checks the fault last for 150 seconds, then it jumps to Sleep&Off mode. -> If unrecoverable fault is present, OBC goes to shutdown mode immediately. Refer to the attachment for the defined faults.</p>		
}				
Justification				
Reference requirements *	{ }	Verification method	UnitTest	
Source reference		Source type *	InternallyDerived	
Source location				
Status *	Accepted	Skill allocation *	ApplicativeSoftware	
Status justification				
Functional group		Function		
Further information				
History	Date *	Name *	Object *	
{ First issue }	{ 2014/5/29 }	{ SIXIONG ZENG }	{ Define SW requirement }	

6.3 Transitions

Requirement ID	PTS_R_014010_01_075.01		Level	RequirementDefinition
Safety level *		Requirement type *	Performance	
Name *	Transitions			
Description *	{			
	Transitions	Description		
	T0	CAN ID 0x60A wake up or CP wake up or KL30 power on wake up		

	T1	OBC downloads default setting successfully.	
	T2	CP is OK. BMS_CCS_AtVCtrl = 1, No fault.	
	T3	CP is OK. BMS_CCS_AtVCtrl = 0, No fault.	
	T4	Fault appears.	
	T5	Initialization failure happens, or recoverable fault appears over 500ms or unrecoverable fault appears.	
	T6	BMS_CCS_SlpCtrl=1, or CC/CP connected and BMS_CCS_AtVCtrl = 0 over 2 minutes, or CC/CP not connected and CAN lost over 1.5 seconds.	
	T7	Shut down complete.	
	T8	Any fault appears.	
	T9	Failure disappears	
	T10	(1)Unrecoverable fault appears. (2) or recoverable failure does not disappear within 150s. (3) or BMS_CCS_SlpCtrl=1	
	T11	Output current less than 12A or high temperature	
	T12	Output current equals to 12A and high temperature return to normal.	
}			
Justification			
Reference requirements *	{ }	Verification method	IntegrationTest
Source reference		Source type *	Internal
Source location			
Status *	Accepted	Skill allocation *	SystemEngineering
Status justification			
Functional group		Function	
Further information			
History	Date *	Name *	Object *
{ First issue }	{ 2014/5/29 }	{ SIXIONG ZENG }	{ Define HW/SW requirement }

6.4 Sleep mode

Requirement ID	PTS_R_014010_01_080.01	Level	RequirementDefinition
Safety level *		Requirement type *	Functional
Name *	{ Sleep mode }		
Description *	{ The gateway shall set OUT_SUPPLY_OFF and instruct the CAN transceiver to sleep via SPI. }		
Justification			

Reference requirements *	{ }	Verification method	IntegrationTest
Source reference		Source type *	InternalStandard
Source location			
Status *	Accepted	Skill allocation *	Hardware/Software
Status justification			
Functional group		Function	
Further information			
History	Date *	Name *	Object *
{ First issue }	{ 2014/8/6 }	{ SIXIONG ZENG }	{ Define HW/SW requirement }

6.5 Charging functions

Requirement ID	PTS_R_014010_01_081.01	Level	RequirementDefinition
Safety level *		Requirement type *	Functional
Name *	{ Charging functions }		
Description *	<p>{</p> <p>1. Start charging</p> <p>The BMS shall instruct the OBC to start charging. The start charging sequence shall be followed as long as the BMS requires charging and no alarms in the power stage or gateway are present</p> <p>(1). Ensure that the control pilot PWM is present with a valid duty cycle and frequency. The duty cycle specifies the maximum input current from the charging station.</p> <p>(2). Ensure that the proximity signal is valid (type 2) with a 16A maximum input current.</p> <p>(3). Lock the charging plug and verify that it is locked.</p> <p>(4). Set S2 (pin 144) high. This action tells the charging station to supply power.</p> <p>(5). Wait 200 milliseconds and read the mains voltage from the power stage. If present, continue to next step.</p> <p>(6). Inform the power stage to start charging</p> <p>(7). Verify charging by reading the charging status from the power stage (Charge state should be reached within 5 seconds).</p> <p>(8)Gateway state machine transition Standby to precharge to charge.</p> <p>2. Stop charging</p> <p>(1). Inform the power stage to stop charging.</p> <p>(2). Set S2 (pin 144) low. This action tells the charging station to open its relays and disconnect mains.</p> <p>(3). Unlock the charging plug and verify that it is unlocked.</p> <p>(4). Inform the BMS about the reason for stopping charging</p> <p>(5). Gateway stops CAN communication and enters sleep mode after 2 minutes. Only LEDs are controlled during this period.</p> <p>3. Charging</p> <p>The OBC shall remain in the Charging state (charging) as long as the BMS requires or until the gateway or power stage detects a failure.</p> <p>The maximum requested output voltage, output current, output power and input current limits from the BMS shall be respected during charging. The gateway shall perform a quality control of the limits and forward them to the power stage.</p> <p>}</p>		

Justification			
Reference requirements *	{ }	Verification method	IntegrationTest
Source reference		Source type *	InternalStandard
Source location			
Status *	Accepted	Skill allocation *	Hardware/Software
Status justification			
Functional group		Function	
Further information			
History	Date *	Name *	Object *
{ First issue }	{ 2014/8/6 }	{ SIXIONG ZENG }	{ Define HW/SW requirement }